

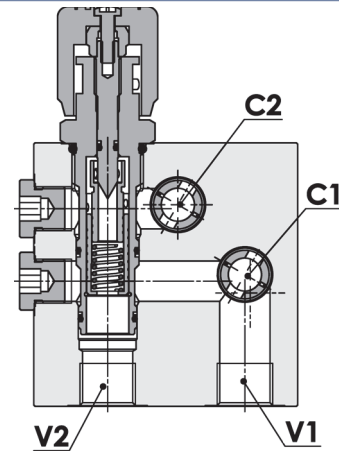

Regolatore di flusso a 3 vie compensato, con eccedenza a scarico, flangiabile su motori Char-Lynn 2000
Three way, pressure compensated flow regulator, with exceeding flow to tank, flangeable on Char-Lynn 2000 motors

Rev.01-2010/02

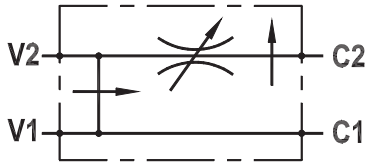

SPECIFICHE TECNICHE

Materiali: cartucce in acciaio zincato, parti interne in acciaio trattato termicamente. Corpo in lega di alluminio.

Portata max.:

- 90 l/min con 60 l/min su ramo regolato "C2"

Pressione max: 250 bar (corpo in alluminio)

Pressione di standby: 10 bar

Peso: 1,500 Kg

TECHNICAL SPECIFICATIONS

Materials: cartridges in steel zinc plated, internal parts in hardened steel. Body is in high strenght aluminium alloy.

Rated flow:

- 90 l/min with 60 l/min in "C2" port

Max. pressure: 250 bar (aluminium body)

Standby pressure: 10 bar

Weight: 1,500 Kg

DIAGRAMMA COMPENSAZIONE - COMPENSATION CURVES

Viscosità olio 24 mm²/sec. (3,5 °E)
 Temperatura 50 °C

Oil viscosity 24 mm²/sec. (3,5 °E)
 Temperature 50 °C

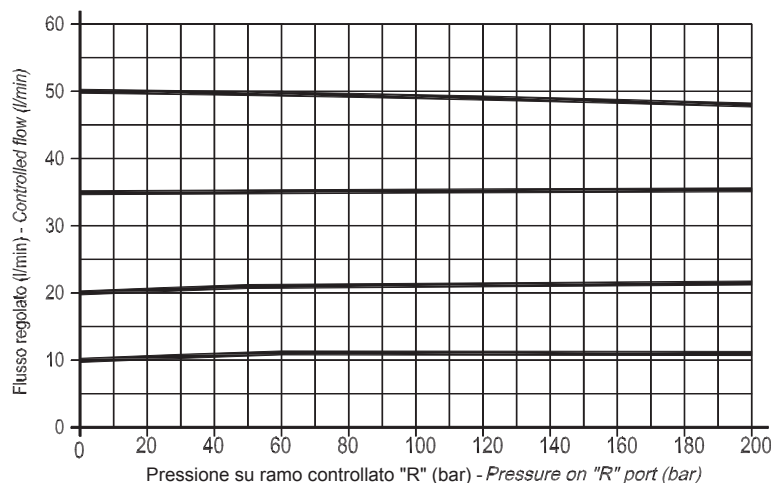

Regolatore di flusso a 3 vie compensato, con eccedenza a scarico, flangiabile su motori Char-Lynn 2000
Three way, pressure compensated flow regulator, with exceeding flow to tank, flangeable on Char-Lynn 2000 motors

Rev.01-2010/02

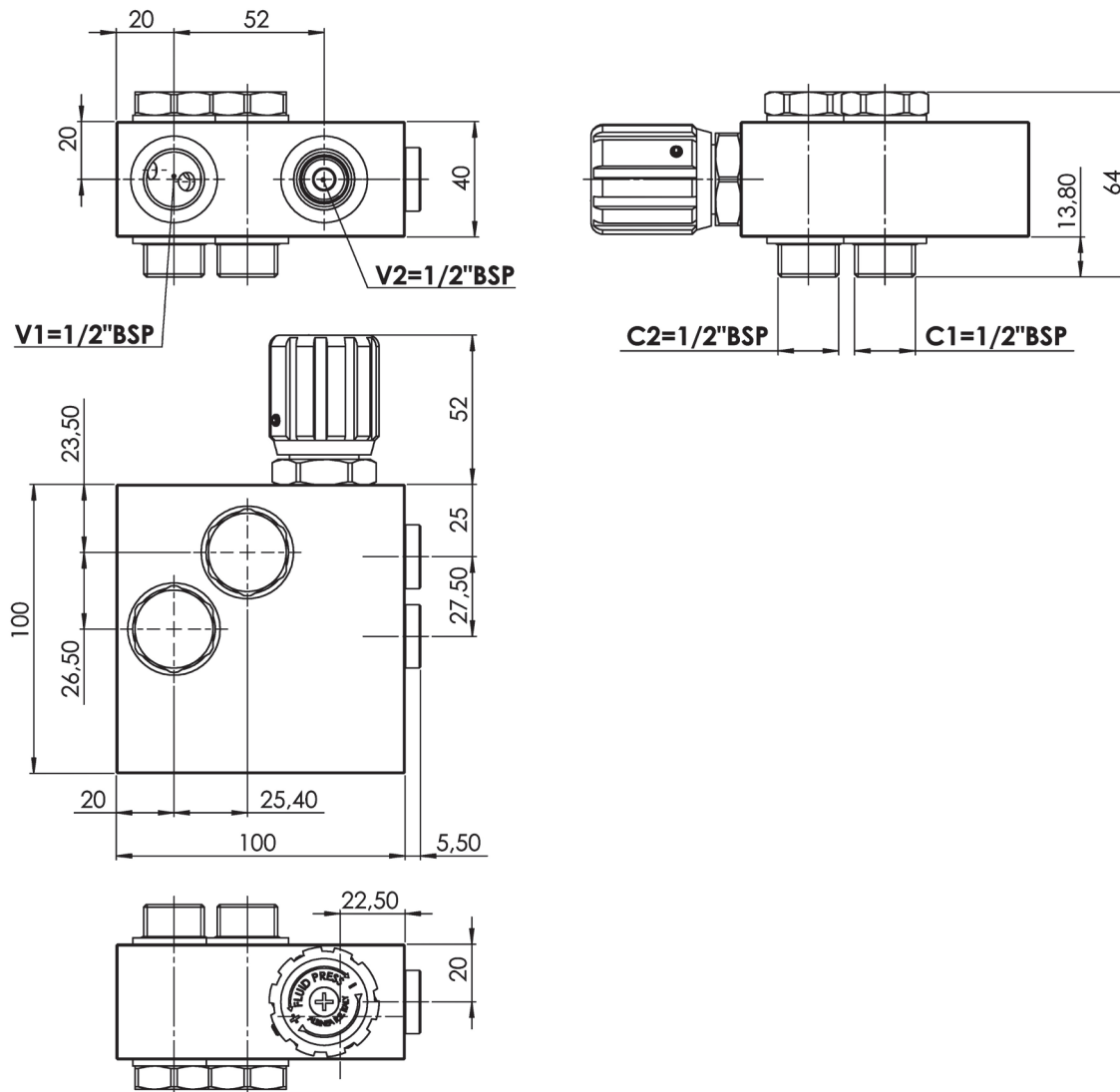

ESEMPIO DI ORDINAZIONE - ORDERING CODE EXAMPLE

F P R F 9 0 D V E 6 R 1 / 2 S

Materiale corpo - body material
 Omettere se alluminio *
 Omit if aluminum
 S = acciaio - steel