

**OLAER  
A-LHC  
COOLERS**

# AIR OIL COOLER

*Olaer A-LHC with hydraulic motor for mobile and industrial hydraulic systems*



 **OLAER**<sup>®</sup>  
**FAWCETT CHRISTIE**

# FOR HEAVY DUTY COOLING OF HYDRAULIC SYSTEMS

Olaer A-LHC, a series of air oil coolers with hydraulic motors, is recommended for heavy duty operations, mobile as well as industrial, where high capacity oil coolers are a requirement.

From the Olaer A-LHC series, we can supply oil coolers of Olaer's well known high quality, at short notice.

The Olaer A-LHC series of air oil coolers can be fitted with a thermo contact for oil temperature control.

---

Cooler matrix with low pressure drop and high cooling capacity.

---



## Maximised heat transfer and capacity

The Olaer A-LHC series of air oil coolers, fitted with hydraulic motors, is designed for heavy duty operations in mobile and industrial systems.

The ideal cooler will provide prolonged oil durability hence extended hydraulic system life, minimize internal potentials for leaks, prolong lubricating qualities and maintain hydraulic efficiency for the entire working cycle.

## Own laboratory

A series of quiet, long-lasting coolers with a high cooling capacity per unit of surface area and a low pressure drop is the result from extensive research, development and testing in our own laboratory.

The components are carefully selected to ensure optimum performance.

## Collar bearings provide extended service life

Olaer A-LHC air oil coolers are ideal for mobile applications primarily because of their small size and light weight but also because they are quiet.

Olaer A-LHC coolers have high physical strength, are easy to retrofit on many types of machines and offer unlimited utilization of all standby units. Large models of Olaer A-LHC coolers are equipped with collar bearings for extended hydraulic motor life.

## Calculate your cooling requirement

Olaer has developed a calculation program where, by entering your basic data, you can calculate your cooling requirement and select the correct cooler. The program is available from your local Olaer company.

For sizing, selection of the ideal cooler and associated information, see separate technical information sheet.

The Olaer Group is represented worldwide providing you with support wherever you are located.

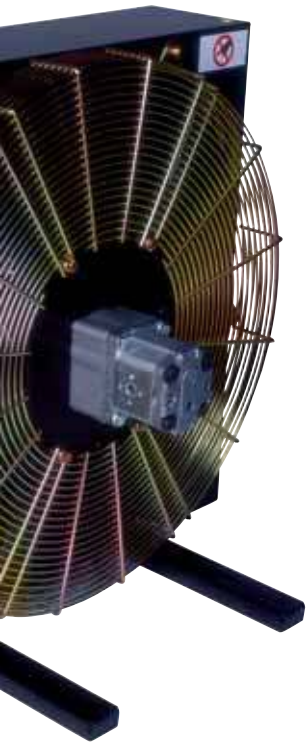

Different by-pass functions are available to protect against cold starts.

---

Can be fitted with dust and stone guard.

---

Hydraulic motor with displacement from 8 to 25 cc.

---

Collar bearing on larger versions for extended hydraulic motor life.

---

## Olaer A-LHC coolers for all applications

### Mobile

- Cranes
- Harvesters
- Graders
- Rollers
- Contractors machines
- Wet brakes
- Rail-borne machines
- Picking machinery
- Earth drilling machines
- Concrete pumps
- Mining equipment
- Bulk loaders
- Fork-lift trucks
- Rock drills
- Geological investigation machinery
- Ditch excavators
- Forestry machinery
- Forwarders
- Asphalt spreaders
- Street-cleaning machines
- Snow slingers
- Cable laying machines
- Garbage collection trucks
- Ready-mix concrete trucks
- Agricultural machinery
- Compressors
- Motor oil cooling
- Power Generating Units
- Scrapping machinery

**Consult your local  
Olaer company for:**

- type
- applications
- system construction
- sizing
- extreme operational conditions

# AIR OIL COOLER

## *Olaer A-LHC with hydraulic motor - Technical specification*

For selection of the ideal oil cooler; find out required  
cooling capacity  
oil flow  
oil temperature  
max air temperature  
or use our calculation program.

**A-LHC 007 - A-LHC 023**

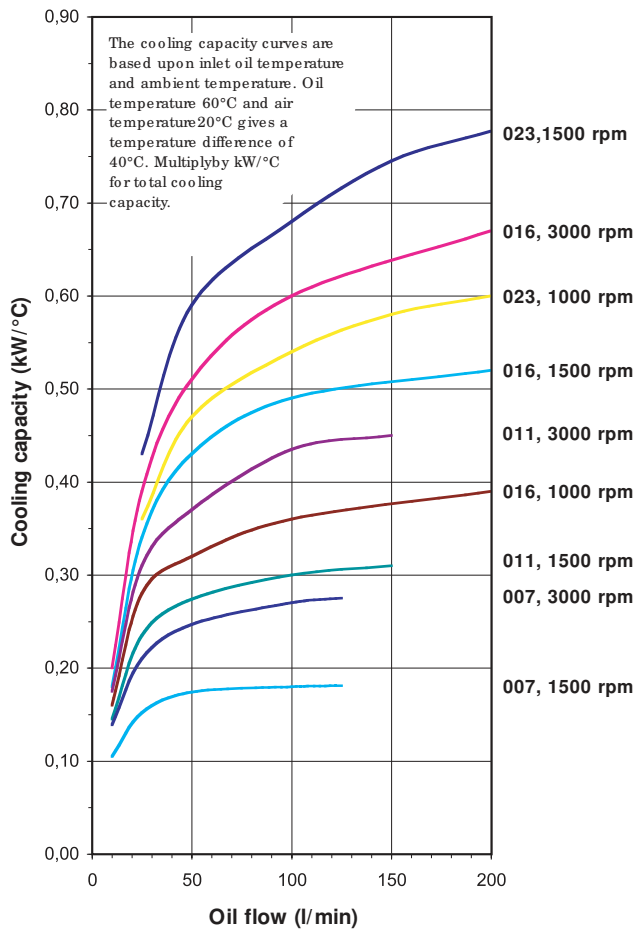

**A-LHC 033 - A-LHC 112**

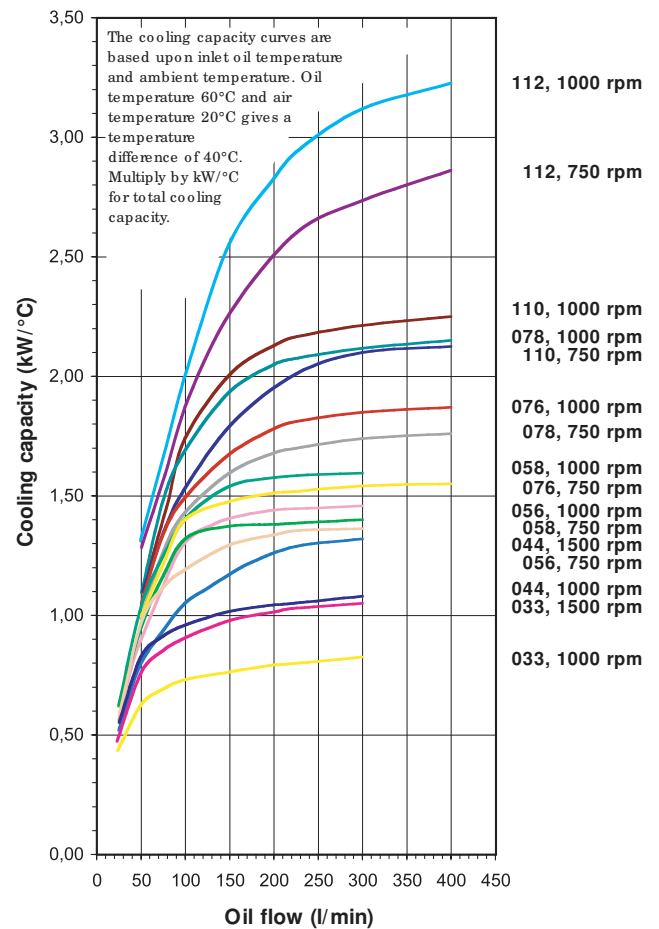

Pressure drop at 30 cSt (single-pass)

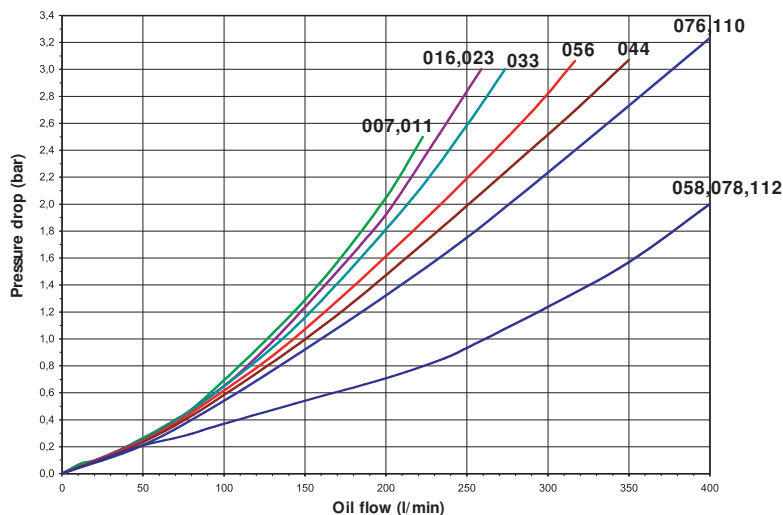

General drawing

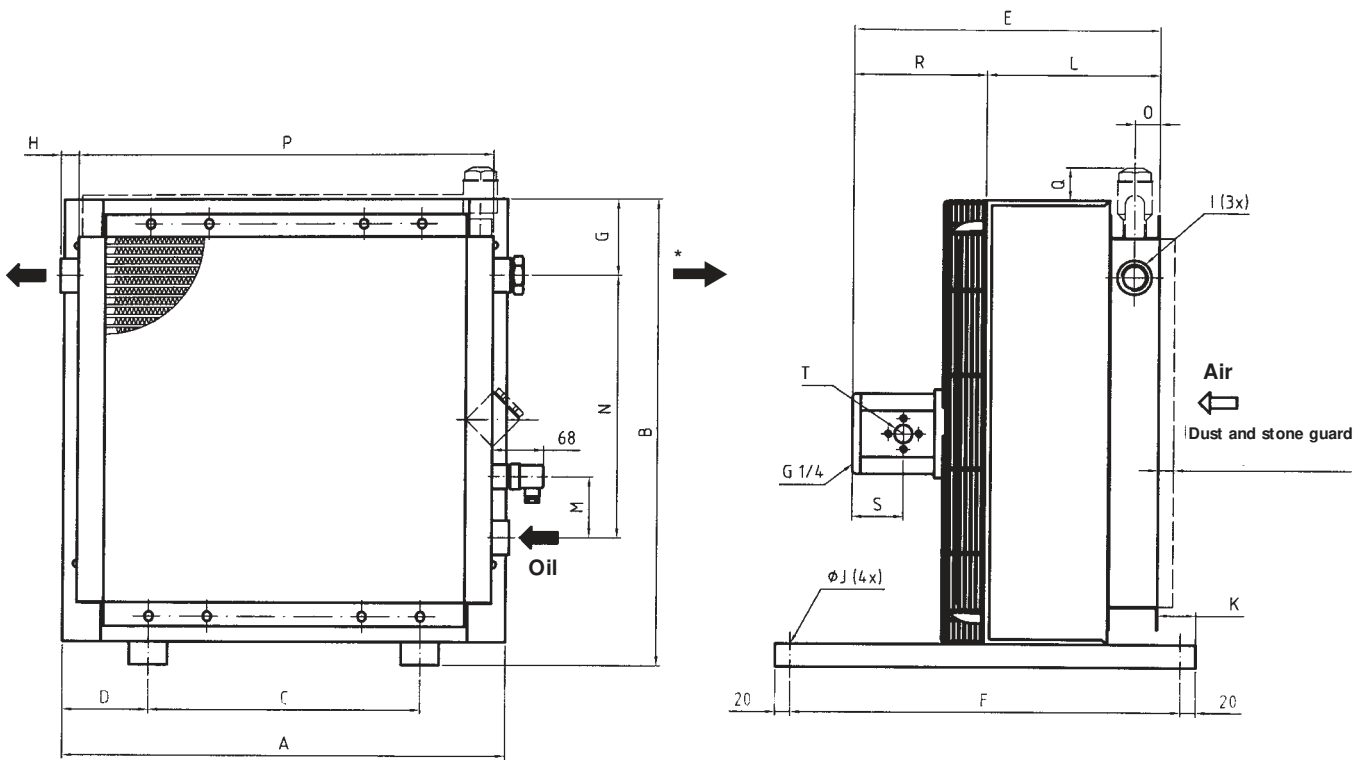

\* Oil outlet when a by-pass valve type T or a two pass is used

Type	Fan rpm	Air flow m <sup>3</sup> /s	Fan performance kW	Weight ca kg	Max. rpm	Acoustic pressure level dB(A) 1 m*
<b>A-LHC 007</b>	1500	0,3	0,10	10	3500	64
	3000	0,6	0,65	10	3500	79
<b>A-LHC 011</b>	1500	0,5	0,20	15	3500	69
	3000	0,9	1,50	15	3500	83
<b>A-LHC 016</b>	1000	0,5	0,10	18	3350	63
	1500	0,8	0,35	18	3350	73
	3000	1,5	2,50	18	3350	86
<b>A-LHC 023</b>	1000	0,8	0,15	30	2840	66
	1500	1,2	0,50	30	2840	77
<b>A-LHC 033</b>	1000	1,7	0,65	40	2350	75
	1500	2,5	2,00	40	2350	85
<b>A-LHC 044</b>	1000	2,1	0,65	56	2350	77
	1500	3,1	2,00	56	2350	86
<b>A-LHC 056</b>	750	2,5	0,75	70	1850	74
	1000	3,3	1,80	70	1850	82
<b>A-LHC 058</b>	750	2,1	0,75	77	1850	75
	1000	2,9	1,80	77	1850	83
<b>A-LHC 076</b>	750	3,0	0,70	105	1690	80
	1000	4,0	1,60	105	1690	87
<b>A-LHC 078</b>	750	2,7	0,70	111	1690	81
	1000	3,7	1,60	111	1690	88
<b>A-LHC 110</b>	750	5,3	1,70	117	1440	85
	1000	7,1	4,00	117	1440	91
<b>A-LHC 112</b>	750	4,5	1,70	125	1440	86
	1000	6,1	4,00	125	1440	92

\* Noise level tolerance  $\pm 3$  dB(A)

## Dimensions

Type	A	B	C	D	E	F	G	H	I	J	K	L	M	N	O	P	Q*	Motor selection
<b>A-LHC 007</b>	365	395	203	81	R+L	510	103	23	G1	9	50	190	80	160	33	330	42	A-F
<b>A-LHC 011</b>	440	470	203	119	R+L	510	106	23	G1	9	50	215	80	230	33	400	39	A-F
<b>A-LHC 016</b>	496	526	203	147	R+L	510	100	23	G1	9	50	240	80	230	33	464	45	A-F
<b>A-LHC 023</b>	580	610	356	112	R+L	510	101	23	G1	9	50	265	80	305	33	543	44	A-F
<b>A-LHC 033</b>	692	722	356	168	R+L	510	103	25	G1¼	9	50	240	80	406	33	635	43	A-F
<b>A-LHC 044</b>	692	866	356	168	R+L	510	87	25	G1¼	9	50	265	80	584	33	635	59	A-F
<b>A-LHC 056</b>	868	898	508	180	R+L	510	102	25	G1¼	9	50	290	80	584	33	802	44	A-F
<b>A-LHC 058</b>	868	898	508	180	R+L	510	102	31	G2	9	30	310	100	584	43	802	44	A-F
<b>A-LHC 076</b>	1022	1052	518	252	R+L	610	101	31	G1½	14	70	315	100	821	33	940	45	B-F
<b>A-LHC 078</b>	1022	1052	518	252	R+L	610	101	31	G2	14	50	335	100	821	43	940	45	B-F
<b>A-LHC 110</b>	1185	1215	600	293	R+L	610	100	31	G2	14	70	340	100	985	33	1130	46	D-F
<b>A-LHC 112</b>	1185	1215	600	293	R+L	610	100	31	G2	14	50	360	100	985	43	1130	46	D-F

\* "Q" When selecting a by-pass valve type S

Motor type	Displacement (cm <sup>3</sup> /r)	R 007-023	R 033-112	S	T Connection	Max. working pressure (bar)
<b>A</b>	8,4	107	211	52,5	G½	210
<b>B</b>	10,8	111	215	52,5	G½	210
<b>C</b>	14,4	117	221	55,5	G¾	210
<b>D</b>	16,8	121	225	59,5	G¾	210
<b>E</b>	19,2	125	229	59,5	G¾	210
<b>F</b>	25,2	135	239	66,5	G¾	160

Ordering key for Olaer A-LHC air oil cooler.  
When ordering every item should be specified.

**A-LHC-XXX-X-XX-XXX-X-X**  
**1 2 3 4 5 6 7**

**1. Air oil cooler fitted with hydraulic motor = A-LHC**

2. Cooler size	
007	056
011	058
016	076
023	078
033	110
044	112

4. Thermo contact	
Without thermo contact	= 00
40°C	= 40
50°C	= 50
60°C	= 60
70°C	= 70
80°C	= 80
90°C	= 90

3. Hydraulic motor, displacement	
Without hydraulic motor	= 0
Hydraulic motor, displacement 8,4 cm <sup>3</sup> /r	= A
Hydraulic motor, displacement 10,8 cm <sup>3</sup> /r	= B
Hydraulic motor, displacement 14,4 cm <sup>3</sup> /r	= C
Hydraulic motor, displacement 16,8 cm <sup>3</sup> /r	= D
Hydraulic motor, displacement 19,2 cm <sup>3</sup> /r	= E
Hydraulic motor, displacement 25,2 cm <sup>3</sup> /r	= F
Special hydraulic motor	= X

(X: pressure, displacement, mounting dimensions etc., should be specified in text en clair)

5. Cooler matrix	
Standard	= 000
Two pass	= T00
Built-in pressure controlled by-pass valve, single-pass	
2 bar	= S20
5 bar	= S50
8 bar	= S80
Built-in pressure controlled by-pass valve, two-pass	
2 bar	= T20
5 bar	= T50
8 bar	= T80
Built-in temperature- and pressure controlled by-pass valve, single-pass	
50°C, 2.2 bar	= S25
60°C, 2.2 bar	= S26
70°C, 2.2 bar	= S27
90°C, 2.2 bar	= S29
Built-in temperature- and pressure controlled by-pass valve, two-pass	
50°C, 2.2 bar	= T25
60°C, 2.2 bar	= T26
70°C, 2.2 bar	= T27
90°C, 2.2 bar	= T29

6. Matrix guard	
Without guard	= 0
Stone guard	= S
Dust guard	= D
Dust and stone guard	= P

7. Standard/special	
Standard	= 0
Special	= Z

**Example: A-LHC-016-B-50-S20-S-0**

When ordering a special cooler, specify product, components, performance, dimensions etc., in text en clair  
Price and time of delivery available on request.

For further information and latest modifications, please enter our web site [www.olaer.com.au](http://www.olaer.com.au)  
To facilitate selection of the correct cooler, order Olaer's calculation programme.

Fluid compatibility	
Mineral oil	HL/HL to DIN 51524
Oil/Water emulsion	HFA, HFB to CETOP RP 77H
Water glycol	HFC to CETOP RP 77H
Phosphate ester	HFD-R to CETOP RP 77H

Material	
Matrix	Aluminium
Fan blades/hub	Glass fibre reinforced polypropylene/Aluminium
Fan housing	Steel
Fan guard	Steel
Other parts	Steel
Surface treatment	Electrostatically powder coated

Technical specification, matrix	
Maximum static working pressure	21 bar
Dynamic working pressure	14 bar. Tested according to ISO/DIS 10771-1
Limits of heat transfer	± 6 %
Maximum oil inlet temperature	120°C.

Cooling capacity curves
The cooling capacity curves in this technical sheet are based upon tests according to EN 1048 and are made using oil type ISO VG 46 at 60°C.

Consult your local Olaer company for use
<ul style="list-style-type: none"> <li>• with oil temperature &gt; 120°C</li> <li>• with oil viscosity &gt; 100 cSt</li> <li>• in aggressive environments</li> <li>• in ambients rich in particles</li> <li>• at high altitudes</li> </ul>

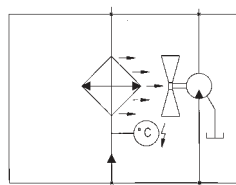

Piping diagram for  
Olaer A-LHC air oil cooler



Oil Solutions

PO Box 38  
Strathfieldsaye, VIC, 3551  
1800 OIL SOL  
1800 645 765

[sales@oilsolutions.com.au](mailto:sales@oilsolutions.com.au)

[www.oilsolutions.com.au](http://www.oilsolutions.com.au)

"For All Your Hydraulic Needs"



**OLAER  
COOLERS**

# THE COMPLETE PRODUCT RANGE



## OLAER A-LAC

An air oil cooler designed for industrial applications fitted with single-phase or three-phase motor. The components have been developed in our laboratory for optimum performance.  
Max. cooling capacity 130 kW at ETD 40°C.



## OLAER A-LDC

An air oil cooler ideal for mobile applications because of its compact design and light weight, fitted with a 12V or a 24V DC motor. During the development of the A-LDC series of air oil coolers we developed also coolers for small cooling requirements.  
Max. cooling capacity 30 kW at ETD 40°C.



## OLAER A-LHC

An air oil cooler fitted with a hydraulic motor for heavy duty applications with high cooling requirement. The Olaer A-LHC air oil coolers are designed for industrial as well as mobile applications. Max. cooling capacity 130 kW at ETD 40°C.



## OLAER A-LOC

An extremely reliable air oil cooling system consisting of a matrix, a fan and a pump. Fitted with one electric motor only, this cooling system is easy to install and at a very low cost. The Olaer A-LOC cooling system is supplied fit for installation in your system.  
Max. cooling capacity 45 kW at ETD 40°C.



**THE OLAER GROUP AROUND THE WORLD:** AUSTRALIA Olaer FCH. Tel: +61 2 9981 6888. AUSTRIA Olaer Austria GmbH. Tel: +43 7229 80306. BELGIUM S.A. Olaer Benelux. Tel: +32 2 466 15 15. CZECHIA Olaer CZ s.r.o. Tel: +42 5 47125 601-8. DENMARK Oiltech DK. Tel: +45 86 69 20 38. FINLAND Oiltech Hydraulics OY. Tel: +358 9 413 755 00. FRANCE Olaer Industries S.A. Tel: +33 1 41 19 17 00. GERMANY Olaer Industries GmbH. Tel: +49 6842 9204-0. GREAT BRITAIN FCH Ltd. Tel: +44 1244 535515. INDIA FCH India. Tel: +91 802 6533587. ITALY Olaer Italiana S.p.A. Tel: +39 011 991 85 11. KOREA Hyundai Olaer Hydraulic Co. Tel: +82 31 499 0897. NETHERLANDS Olaer Nederland B.V. Tel: +31 76 5412453. NORWAY Oiltech AS. Tel: +47 64 91 11 80. POLAND Oiltech Polska. Tel: +48 22 6738162. SCHWIZERLAND Olaer (Schweiz) AG. Tel: +41 26 492 70 00. SOUTH AFRICA FCH c/o Bolton Products CC. Tel: +27 11 474 3095. SPAIN Olaer-Oiltech Iberica SAU. Tel: +34 933 368 900. SWEDEN Oiltech AB. Tel: +46 8 636 07 00. USA Oil Air Hydraulics Inc. Tel: +1 713 937 89 00.

Please note: Being a renowned manufacturer of cooling systems for hydraulics, Olaer is constantly seeking ways to improve the specification and design of its products and alterations take place continually. The products in this brochure may be updated, altered in any way or discontinued, without prior notice.



1800-OILSOL  
1800-645765

<https://oilsolutions.com.au/>

[sales@oilsolutions.com.au](mailto:sales@oilsolutions.com.au)