

ER..L

Directional solenoid valves
4 ways / 2 positions



A member of



1800-OILSOL
1800-645765

<https://oilsolutions.com.au/>

sales@oilsolutions.com.au

ER..L

Directional solenoid valves
4 ways / 2 positions



- External zinc-plated and corrosion-proof components
- Hardened precision spool and cage to ensure minimal wear, minimum leakage and long life
- Flow path optimized through CFD analysis
- Industry common cavities
- Heavy duty polyurethane seals
- Several types of coil connectors and voltages
- Manual override options
- All ports may be fully pressurized
- Others spools available on demand

DESCRIPTION:

Walvoil launches the new ER cartridge valve series, direct acting solenoid operated, 4-way, 2-position, spool-type.

The new ER valves have been designed to reduce the overall dimensions of the valve in order to obtain more compact HICs (Hydraulic Integrated Circuits), and also to increase the performance in terms of pressure, flow-rate and pressure drops.

OPERATION:

The ER..L valve series is available with different spools and manual override options, which increase the versatility of the product and ensure high flow capacity with reduced space requirements.

Optimized through CFD analysis, the reduction of the pressure drops ensures higher switching performances compared to the existing solution, while maintaining the same type of coils, and complete interchangeability.

These spool-type valves are available in SAE 08 & 10 size and different spools.

They are used in mobile and industrial applications, for the control of travel direction of actuators such as hydraulic motors and cylinders.

ER..L series is assembled with the Walvoil crimping solution, that ensures, at the same time, more robustness while mounting them on HICs and a reduction of leakage due to spool clearance.

Technical specifications and diagrams are measured with mineral oil of 46 cSt viscosity at 40°C (104°F) temperature.

Working condition		ER08L	ER10L
Nominal flow		20 l/min (5.3 US gpm)	40 l/min (10.5 US gpm)
Max. pressure		250 bar (3600 psi)	
Oil leakage	at 210 bar (3050 psi)	40 cm ³ /min (2.44 in ³ /min)	80 cm ³ /min (4.88 in ³ /min)
Fluid		mineral based oil	
Viscosity		10-200 cSt	
Max level of contamination		18/16/13 ISO4406	
Fluid temperature	with NBR seals	from -20°C (-4°F) to 80°C (176°F)	
	with FPM seals	from -20°C (-4°F) to 100°C (212°F)	
Environmental temp. for working conditions		from -20°C (-4°F) to 60°C (140°F)	
Cavity		SAE 08/4	SAE 10/4
Coils type		(BER)	(BC)
Power rating		23 W (12/24 VDC)	26 W (12/24 VDC)
Connector types		ISO4400 - Deutsch DT AMP-JPT - Weatherpack/Metri-pack Flying leads	ISO4400 - Deutsch DT AMP-JPT - Flying leads

Note - For different conditions, please contact Walvoil Sales Department.

NEW

Dimensions and hydraulic circuits

ER08L valve

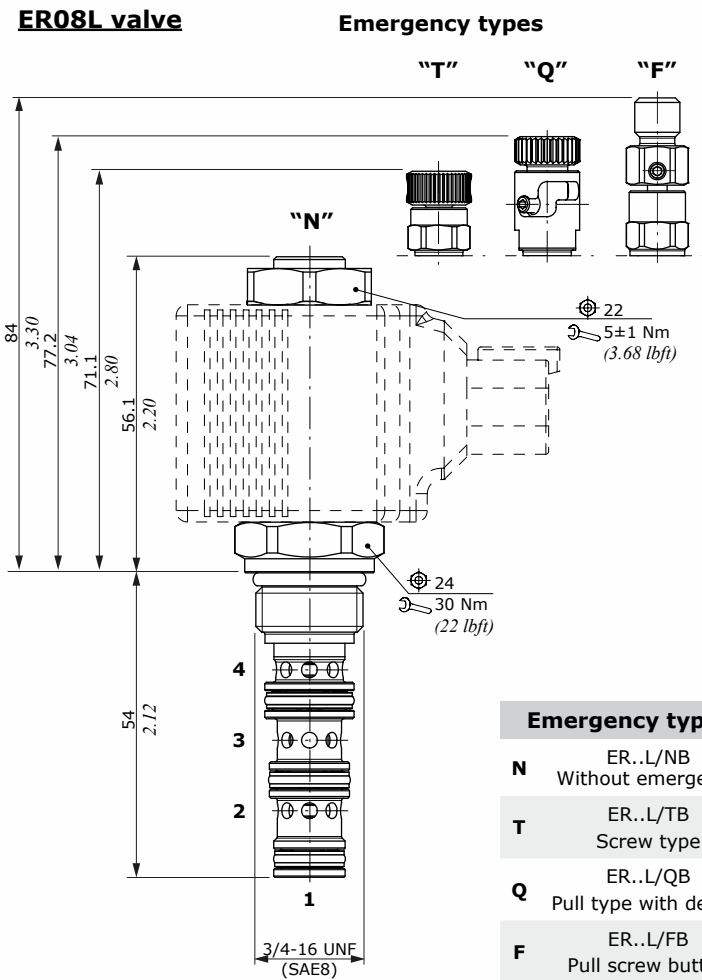

ER10L valve

Emergency types

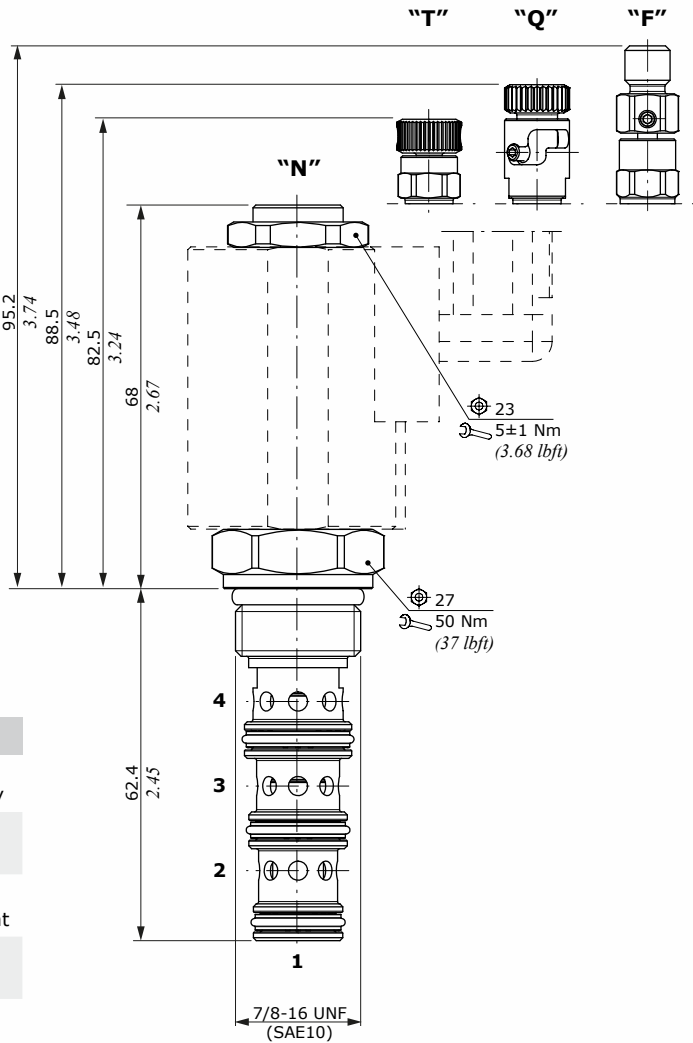

Emergency types

- N** ER..L/NB
Without emergency
- T** ER..L/TB
Screw type
- Q** ER..L/QB
Pull type with detent
- F** ER..L/FB
Pull screw button

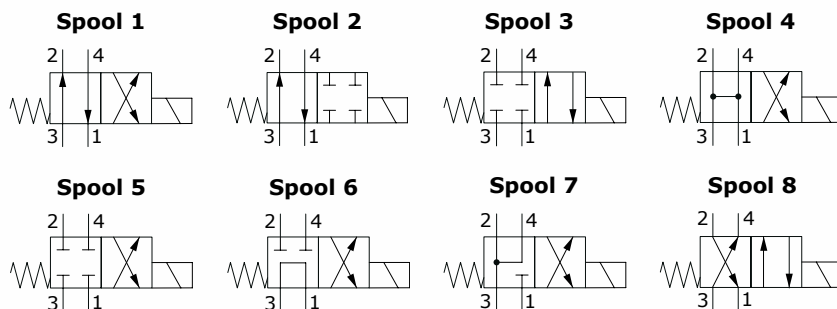

Performance data

ER08L
Pressure drop vs. flow
(spool 7 type)

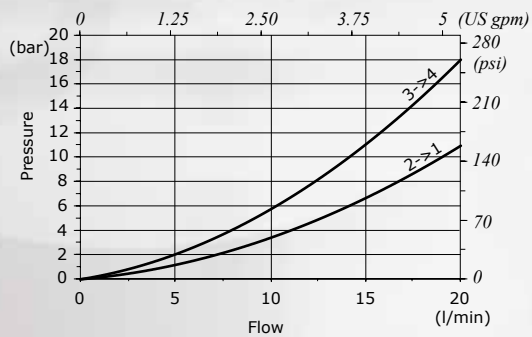

ER10L
Pressure drop vs. flow
(spool 1 type)

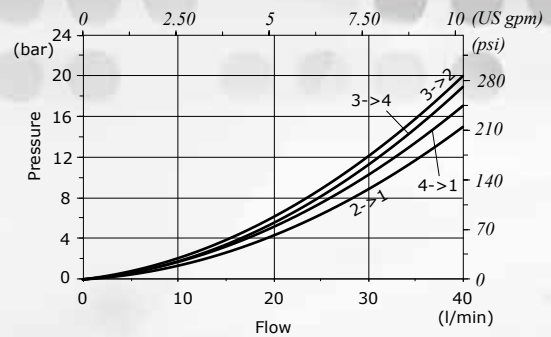

Valves comparison

ER08M - OLD
P= 210 bar (3050 psi)

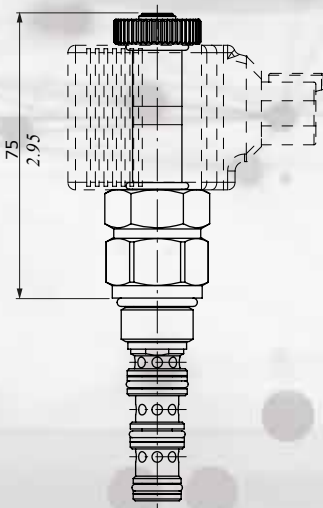

ER08L - NEW
P= 250 bar (3600 psi)

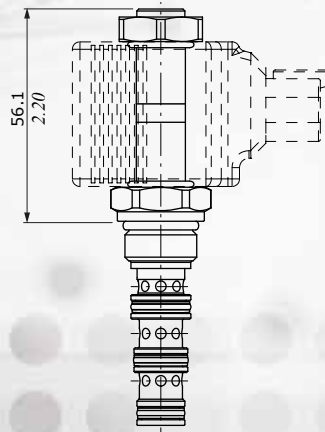

ER10M - OLD
P= 210 bar (3050 psi)

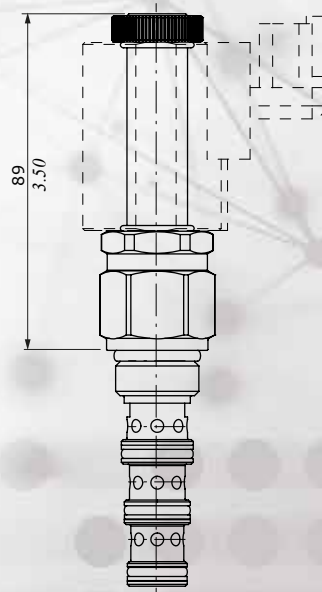

ER10L - NEW
P= 250 bar (3600 psi)

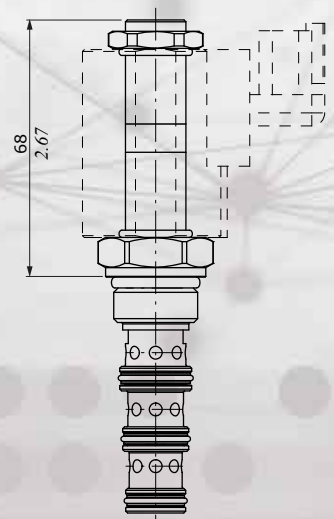

D1WVCI01E - 1st edition October 2021

