



OIL SOLUTIONS

PO Box 38
Strathfieldsaye, VIC, 3551
1800 OIL SOL
1800 645 765
sales@oilsolutions.com.au
www.oilsolutions.com.au
"For All Your Hydraulic Needs"

Service Manual

Orbital X Modular Program

Contents

Chapter 1: Safety precautions.....	5
Safety precautions.....	6
Chapter 2: Assembly instructions.....	7
Overview.....	8
General instructions.....	8
Tools.....	9
Motor assembly.....	10
Exploded parts list.....	10
Fixture of housing.....	11
Spool shaft.....	12
Install washer and axial bearing.....	12
Install check valves.....	12
Install spool shaft.....	13
Distributor plate.....	14
Cardan shaft.....	14
Gear set.....	15
Install end cover.....	16
Clamping.....	17
Needle bearings version.....	19
EMD version - prepared to sensor.....	21
Seal guard.....	23
Chapter 3: Testing.....	25
Required testing.....	26
Hydraulic fluid specifications.....	26
Rotation.....	26
Starting pressure.....	26
Visual inspection of leakage.....	27
Optional testing.....	27
Torque and revolution.....	27
Check valve.....	28
Chapter 4: Motor identification.....	31
Label side port.....	32
Label end port.....	32
Chapter 5: Packaging.....	33
Motor with ø25 mm and 1 inch shaft.....	34
Motor with ø28 mm tapered shaft.....	34
Install shipping plugs.....	34
Shipment.....	34
Chapter 6: Exploded parts list.....	35

Exploded parts list.....	36
Chapter 7: Additional tools needed.....	39
Additional tools needed.....	40
Chapter 8: Tightening table.....	49
Tightening table.....	50

Chapter

1

Safety precautions

Topics:

- [Safety precautions](#)

Safety precautions

Always consider safety precautions before beginning a service procedure. Protect yourself and others from injury. Take the following general precautions whenever servicing a hydraulic system.

Unintended machine movement



Warning:

Unintended movement of the machine or mechanism may cause injury to the technician or bystanders. To prevent unintended movement, secure the machine or disable / dis-connect the mechanism while servicing.

Flammable cleaning solvents



Warning:

Some cleaning solvents are flammable. To eliminate the risk of fire, do not use cleaning solvents in an area where a source of ignition may be present.

Fluid under pressure



Warning:

Escaping hydraulic fluid under pressure can have sufficient force to penetrate your skin causing serious injury and/or infection. This fluid may also be hot enough to cause burns. Use caution when dealing with hydraulic fluid under pressure. Relieve pressure in the system before removing hoses, fittings, gauges, or components. Never use your hand or any other body part to check for leaks in a pressurized line. Seek medical attention immediately if you are cut by hydraulic fluid.

Personal safety



Warning: Protect yourself from injury. Use proper safety equipment, including safety glasses, at all times.

Chapter

2

Assembly instructions

Topics:

- [Overview](#)
 - [Tools](#)
 - [Motor assembly](#)
-

Overview

This manual includes information on assembly and testing of Orbital X motors, OMP X and OMR X.

To provide timely motor delivery when a customer places an order, you need to have all the necessary modules and equipment on hand.

Orbital X is based on a modular building concept. Each motor consists of four modules; housing module, spool shaft module, gear set module and a screw module. When assembled, these four modules constitute a complete motor. Additional feature includes seal guard module and EMD module.

General instructions

Orbital X modules

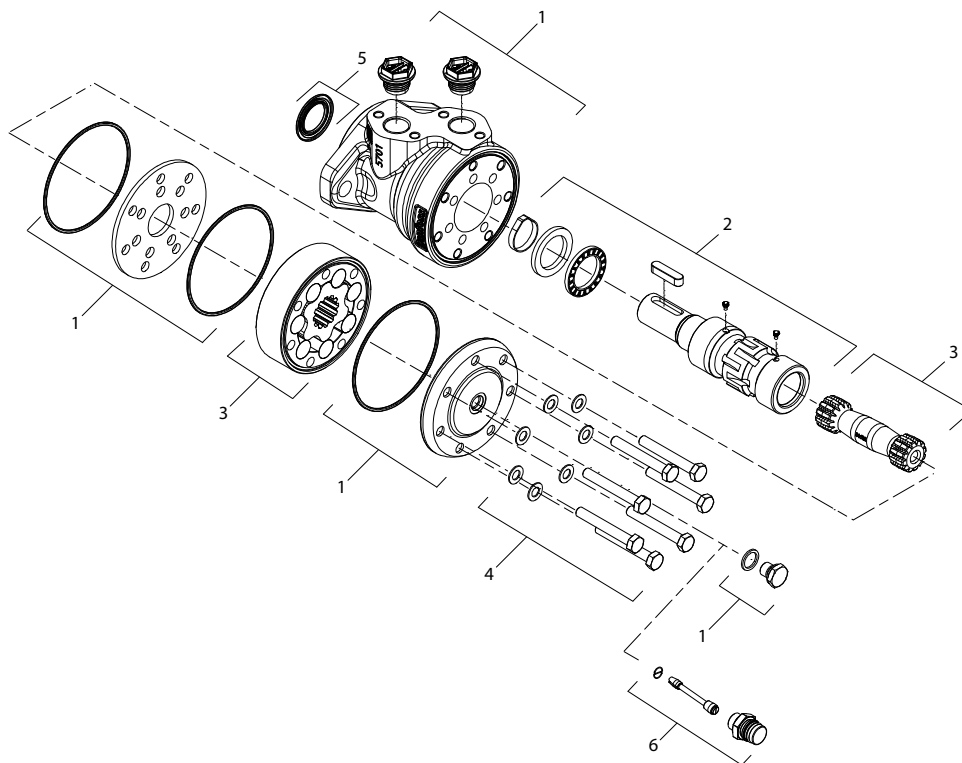

Position	Module
1	Housing Module
2	Spool Shaft Module
3	Gear Set Module
4	Screw Module
5	Seal Guard Module
6	EMD Sensor Module

Figure 1: Orbital X Modules

Keep it clean

Follow these general procedures when assembling Orbital X Motors.

Keep it clean.

As with any precision equipment, keep all parts free of foreign material and chemicals.

Protect all exposed sealing surfaces and open cavities from damage and foreign material.

If left unattended, cover the motor with a protective layer of plastic.

Lubricate O-rings

Lubricate O-rings

Additionally, lubricate all moving parts with oil, such as spool shaft, cardan shaft and gear set.

Tools

Proper assembly of Orbital X motors require following tools. You may use the dimensions and information in the drawings to fabricate them.

A2 flange	ED074545
C-flange	ED075400
OMPW	ED075401
Torpedo	ED074514
Check valve sleeves (to prevent from falling out)	ED075904
Pressing tool for needle bearing	ED074516
S-spring fixture	ED074515
Fork	ED075354
Seal guard	ED075930

Motor assembly

Exploded parts list

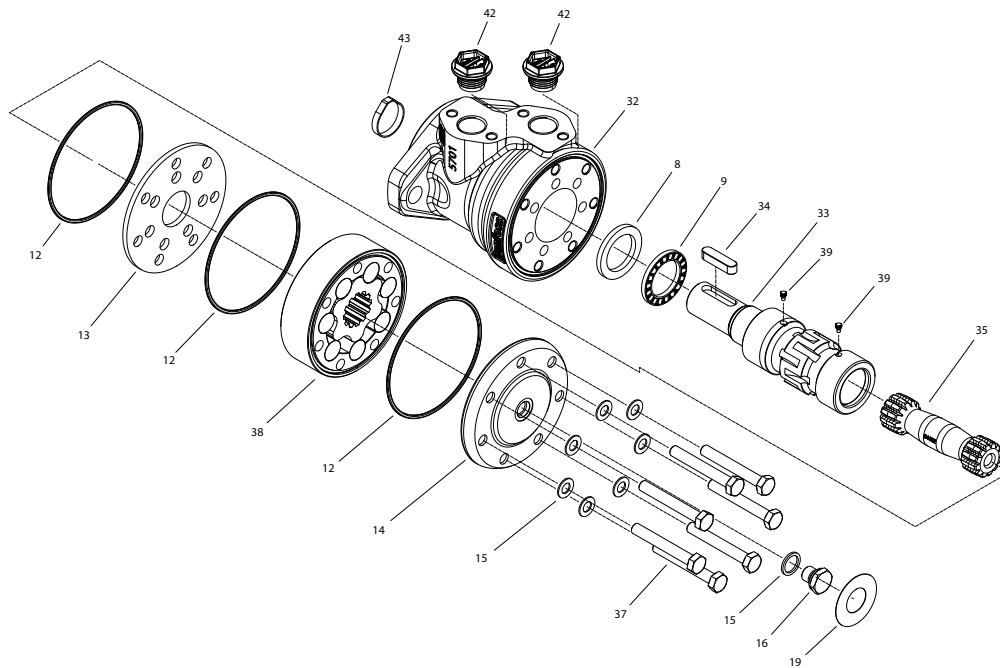

Figure 2: Orbital X Exploded Parts List

Table 1: Orbital X Parts List

Item	Description	Number per unit
8	Washer	1
9	Axial bearing	1
12	O-ring	3
13	Distributor plate	1
14	End cover	1
15	Washer	¹
16	Drain plug	1
19	Label	1
32	Housing (shaft seal is installed at the factory)	1
33	Spool shaft	1
34	Key	1
35	Cardan shaft	1
37	Bolt	¹
38	Gear set	1

¹ Both Washer (15) and Bolt (37) count vary between models of Orbital X.

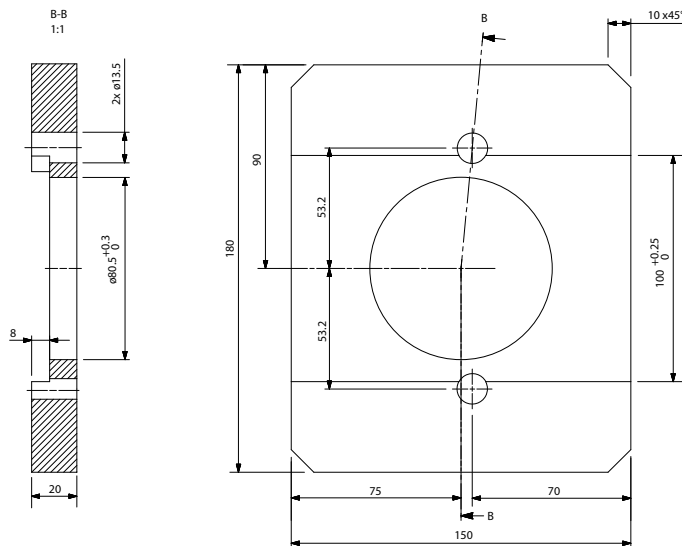

Figure 5: OMPW X

Spool shaft

Install washer and axial bearing

1. Install first washer (8) into housing.
2. Install axial bearing (9) into housing.
3. Install second washer (8) into housing.

Note: Shaft seal is pre-installed at the factory.

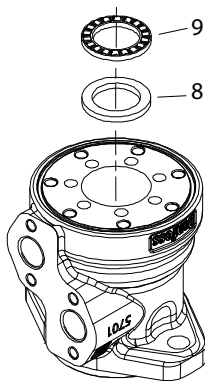

Install check valves

Mount two check valves (39) into the spool shaft.

Press (with fingers) the check valves into place.

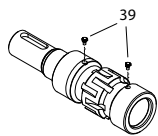

Figure 6: Check valve installation

Install spool shaft

The rear shaft end must be marked before it is fitted. The mark must be positioned vertically above a commutation slot leading up to the front annular channel.

Note: To prevent check valve from falling out and to protect shaft seal during assembly, please use special tools: ED075904 (check valve), and ED074514 (torpedo).

1. Place check valve tool onto housing in one of the commutation holes and O-ring groove.
2. Place torpedo into housing, and press out when shaft is installed.

Shaft should be positioned in two different ways, depending on Motor type (OMP X or OMR X).

OMP X and OMR X **with offset ports** central commutation groove turned about 5 degrees from the center of the housing (counter-clockwise rotation). After inserting spool shaft into housing, turn the shaft so that it aligns with the center of the housing.

OMP X and OMR X **with aligned ports** central commutation groove in coincidence with the center of the housing.

3. Grease the O-ring and put it in the groove of the housing.
4. Ensure the spool shaft edge is slightly below motor housing.

OMP X and OMR X offset ports

The shaft must be positioned with the groove offset with regard to the inner circle of holes in the housing.

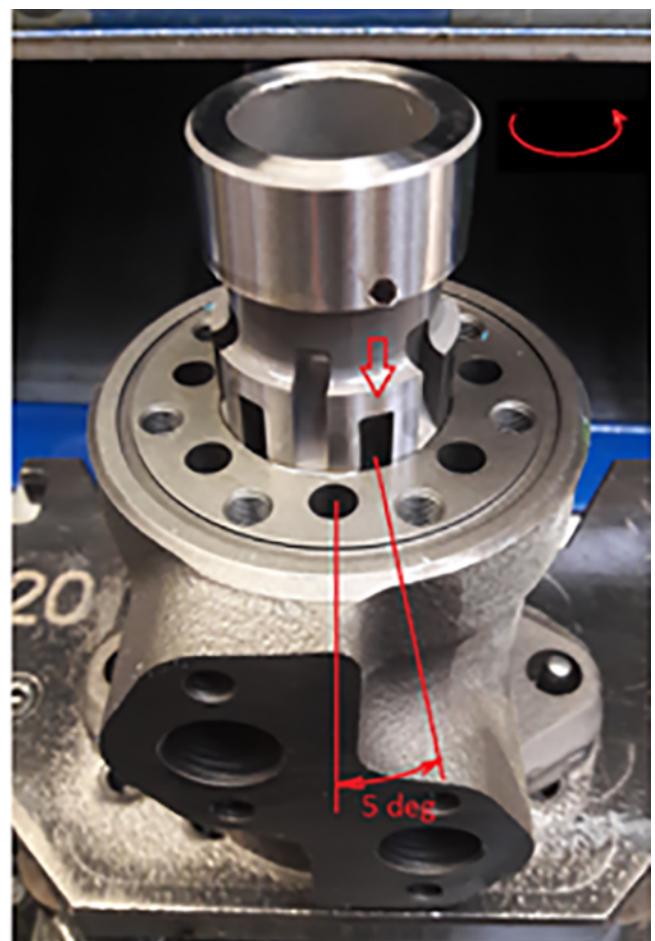

Figure 7: Correct positioning of shaft (offset ports):

OMP X and OMR X aligned ports

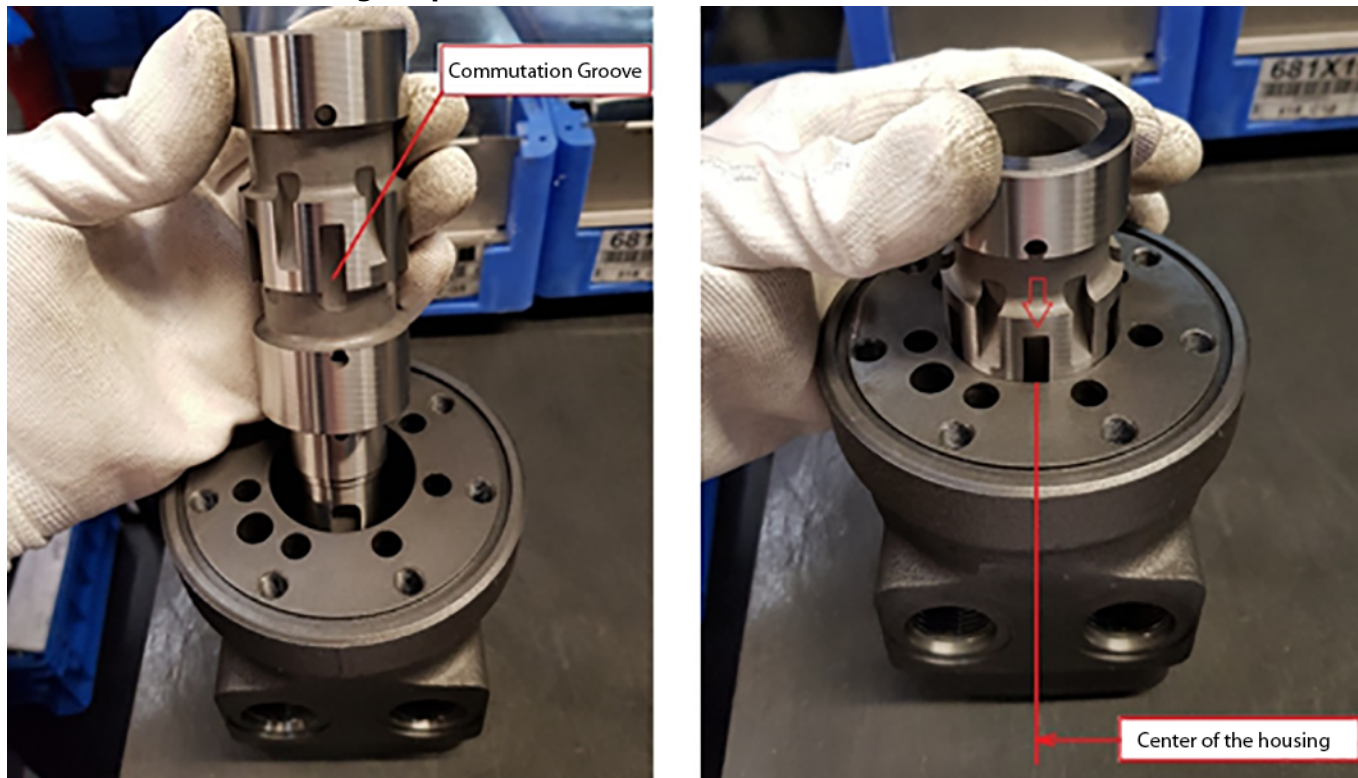

Figure 8: Correct positioning of shaft (aligned ports)

Distributor plate

Mount the distributor plate (pos. 13) on the housing.

Make sure that the distributor plate holes align with holes in the housing.

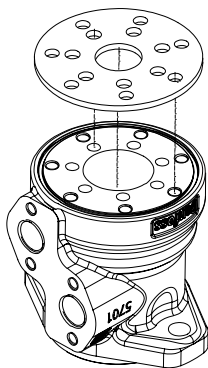
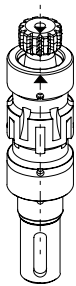

Figure 9: Distributor plate holes must align

Cardan shaft

1. Guide the cardan shaft down into the motor housing.
In case of different spline lengths, turn the cardan shaft to ensure the long spline end is fitted to in the output shaft.



2. Transfer marking from output shaft to cardan shaft.

Figure 10: Marking transfer indicated

3. For smaller displacement, retain the cardan shaft using the fork tool (ED075353).

Fork is needed in the following displacements:

Motor Type	Displacement
OMP X	25
	32
	36
	40
	50
	60
	80
OMR X	36
	50

Gear set

1. Place the O-rings (greased) in the O-ring grooves of the gearwheel.
In gearwheels with non-through splines, place the gearwheel with the recess in the spline hole down towards the housing
2. Place the gearwheel set on the cardan shaft, so that the top of a tooth in the external teeth of the gearwheel is vertically above the mark on the cardan shaft.
3. Turn the gearwheel set counter-clockwise until the cardan shaft and the gearwheel start to mesh (15°).
4. Turn the gearwheel rim so that the holes align the screws properly.

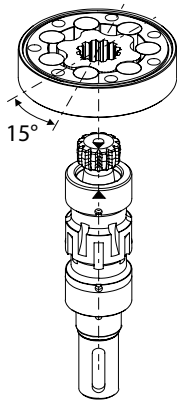
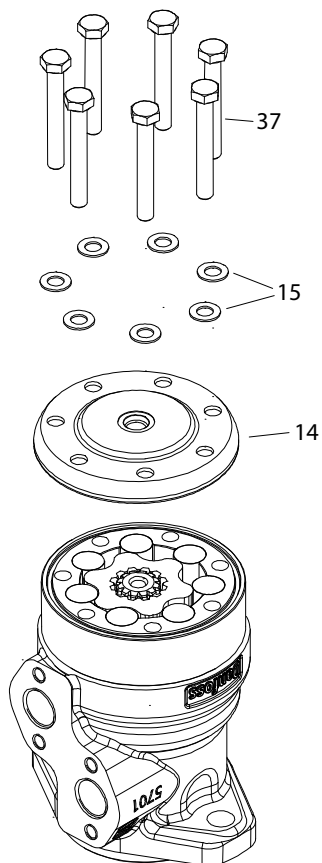

Figure 11: Installation of gearwheel to cardan shaft

Install end cover

1. Turn the end cover (pos. 14) so that the holes line up.
Note the orientation of end cover for Offset Aligned port.
2. Install washers (pos. 15), and end cover bolts (pos. 37).
3. See [Bolt torque and sequence](#) on page 17 to ensure correct assembly.
Depending on differing motor type, bolts vary from 5-7 pieces.



Clamping

Bolt torque and sequence

Start all bolts by hand, two or three turns, to avoid damaging the threads when using a pneumatic wrench.

Bolt sequence:

Standard (7 bolts):

1,2	8 Nm [71 lbf*in] – 10 Nm [88.5 lbf*in] (pre-tightened)
3-9	32.5 Nm [288 lbf*in] \pm 2.5 Nm [22 lbf*in]

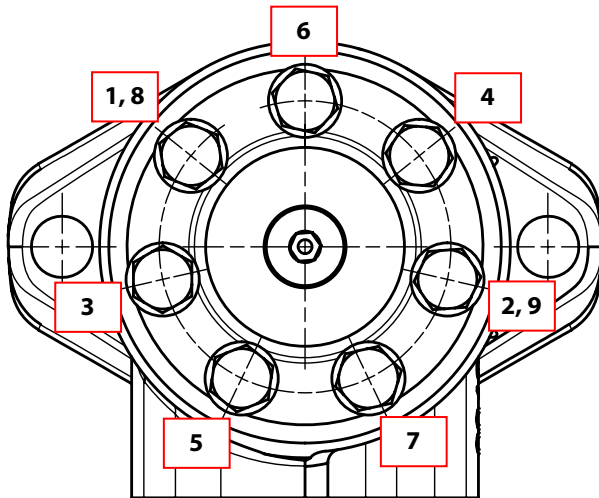

Figure 12: Tightening sequence

OMP X aligned

6 bolts

1,2	8 Nm [71 lbf*in] – 10 Nm [88.5 lbf*in] (pre-tightened)
3-8	32.5 Nm [288 lbf*in] \pm 2.5 Nm [22 lbf*in]

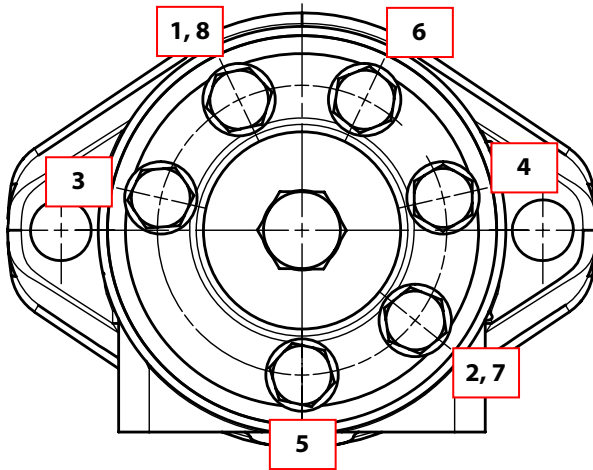

Figure 13: Tightening sequence

End port

5 bolts

1,2	8 Nm [71 lbf*in] - 10Nm [88.5 lbf*in] (pre-tightened)
3-7	32.5 Nm [288 lbf*in] \pm 2.5 Nm [22 lbf*in]

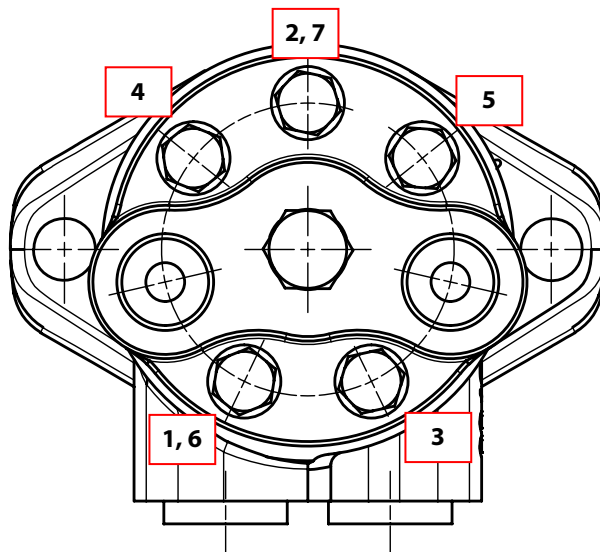

Figure 14: Tightening sequence

Install drain plug

1. Install washer (pos. 15) into end cover.
2. Install drain plug (pos.16) into end cover.

Needle bearings version

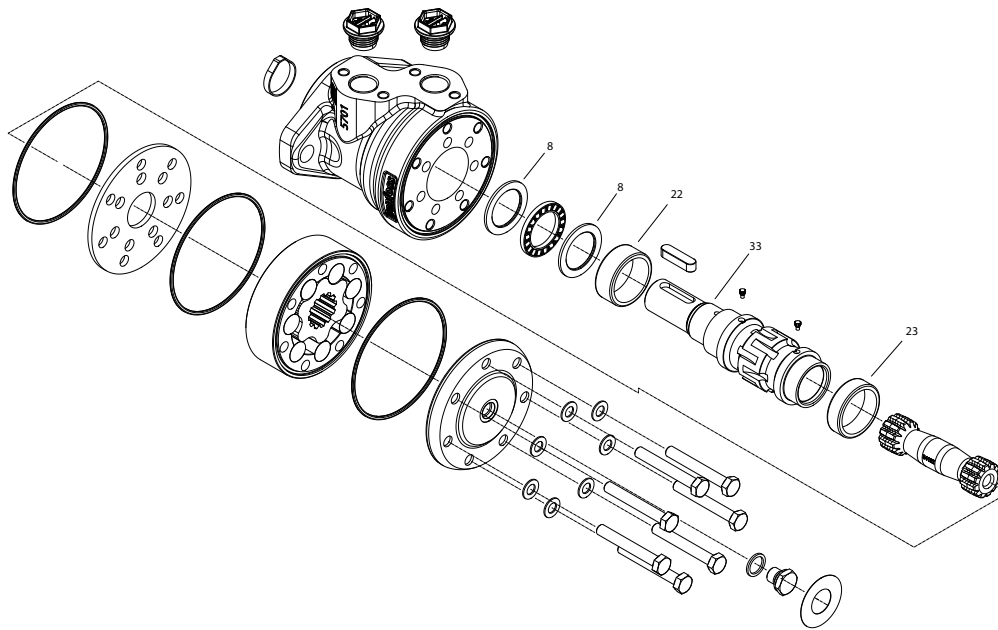

Table 2: Orbital X Parts List

Item	Description	Number per unit
8	Washer	2
9	Axial bearing	1
12	O-ring	3
13	Distributor plate	1
14	End cover	1
15	Washer	¹
16	Drain plug	1
19	Label	1
22	Needle bearing (front)	1
23	Needle bearing (rear)	1
32	Housing (shaft seal is installed at the factory)	1
33	Spool shaft	1
34	Key	1
35	Cardan shaft	1
37	Bolt	¹
38	Gear set	1
39	Check valve	2
42	Plastic plug	2

¹ Both Washer (15) and Bolt (37) count vary between models of Orbital X.

Item	Description	Number per unit
43	Rubber band	1
88	Seal guard	1

Note: Parts 22, 23, and 33 are different from the standard version.

Install needle bearings

Two washers (8), and the axial bearing (9) must be installed into the housing in the order as follows.

1. Install washer (8) into housing.
2. Install axial bearing (9) into housing.
3. Install washer (8) into housing.

Note: Shaft seal is already pressed into the housing.

4. Ensure that the longest needle bearing is in the front, closest to the shaft seal.

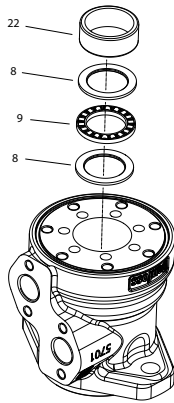

Figure 15: Reference for needle bearing installation

5. Use tool (ED074516) to press needle bearing (22) into housing.

Note:

For this purpose, use a machine press.

Max allowed press force is 6000 N [1350 lbf] ± 300 N [67 lbf].

6. Install spool shaft as previously mentioned.
7. Install last bearing (23) after installing a spool shaft. Repeat the same operation as the former bearing (pos. 22).

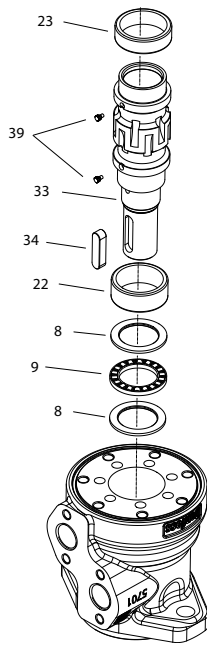

Figure 16: Reference 2 for needle bearing installation

EMD version - prepared to sensor

Install S-spring to cardan shaft

Proper assembly requires tool within ED074515 (S-spring tool).

1. Install the sleeve on small pushing rod.
2. Position S-spring in the sleeve.
3. Insert small pushing rod into mounting tool.
4. Position mounting tool on cardan shaft.
5. Press spring into the cardan shaft using big pushing rod.

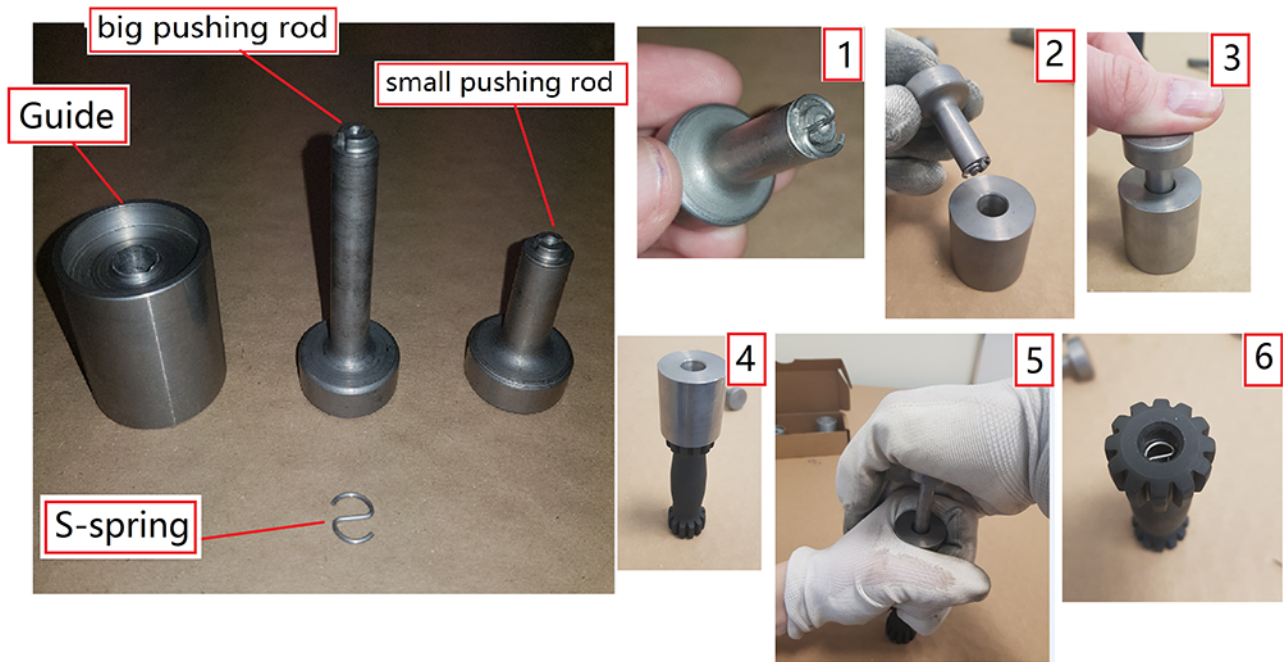
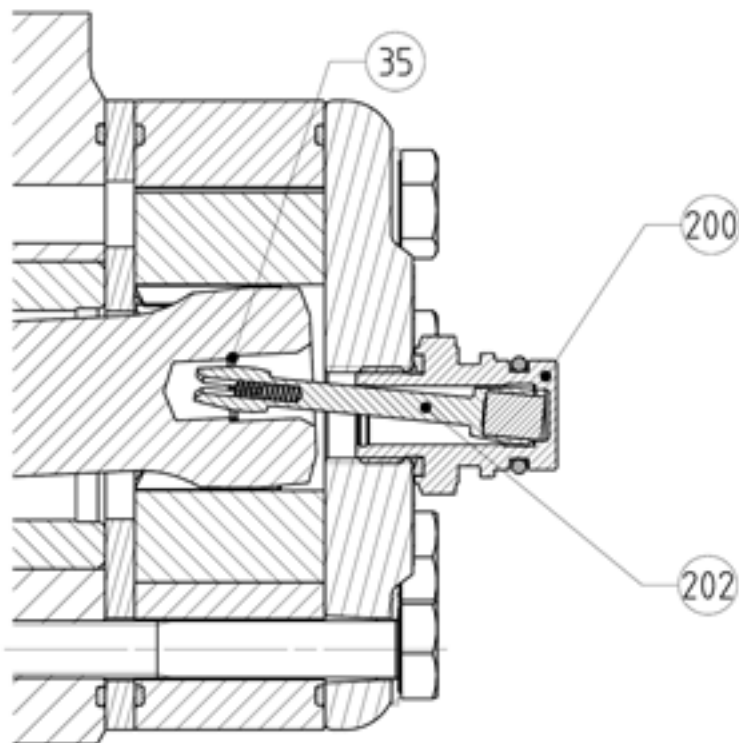

Figure 17: Follow this process to install S-spring.

6. Install Gear set, O-rings, End Cover, clamp bolts, and then mount the EMD shaft (202) into cardan shaft intervention.

Groove of shaft (202) must be inserted on S-spring (35).



Position	Part
35	S-spring

Position	Part
200	Sensor plug
202	EMD shaft

Figure 18: Proper assembly procedure

Note: It is important to mount the EMD shaft groove into pre-installed S-spring.

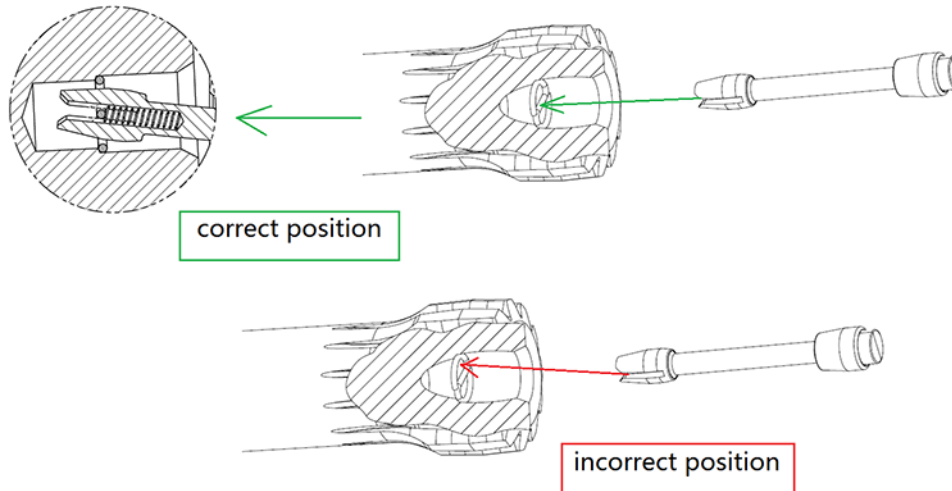

7. Install sensor plug (200).

Tightening torque: 17 Nm [150 lbf*in] \pm 2.5 Nm [22 lbf*in]

Seal guard

Install seal guard

Proper assembly of seal guard requires tool ED075930. Before assembly, add grease onto seal guard.

Place seal guard on shaft and use tool ED075930, along with machine press, to mount the seal guard into the housing.

Max allowed force is 2000 N [450lbf]

If something is not done correctly and the seal guard is damaged, a new seal guard must be used.

Note: It is not possible to mount gamma ring on 1:10 tapered shaft.

Chapter

3

Testing

Topics:

- *Required testing*
 - *Optional testing*
-

Required testing

Hydraulic fluid specifications

General testing conditions	
Fluid type	Mineral hydraulic oil class HM ISO 6743/4
Viscosity range	35 ± 3 cSt
Oil cleanliness	22 18 13 - contamination degree, ISO 4406

Rotation

With the shaft pointing toward you and the system ports facing up, the motor must turn to the right (clockwise) when supplying pressure connection port A.

If the motor begins to turn below the specified pressure, the motor check is OK.

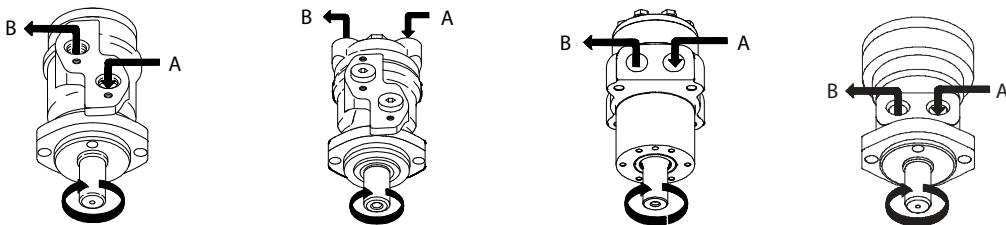

P109280

Starting pressure

1. Disengage the motor and ensure there is no outside load on the output shaft.
2. Slowly raise the oil supply pressure until the motor starts to the appropriate limit (7 or 10 bar [102 or 145 psi]).
3. Check that the motor is still turning at this limit.

If the motor turns at this limit, it is good.

Motor type	Max start pressure	
	7 bar [102 psi]	10 bar [145 psi]
36		x
50		x
80		x
100		x
125	x	
160	x	
200	x	
250	x	
315	x	
375	x	
400	x	

Motor type	Max start pressure	
	7 bar [102 psi]	10 bar [145 psi]
25		x
32		x
36		x
40		x
50		x
60		x
80		x
100		x
125	x	
160	x	
200	x	
250	x	
315	x	
400	x	

Visual inspection of leakage

Check the motor to ensure no visual leakage.

Optional testing

Torque and revolution

If possible we encourage/recommend performing optional test of torque and revolutions.

With a flow at 30 l/min [7.9 g/min] ± 0.15 l/min and differential pressure at 70 bar ± 1 bar [1015 psi] motor should perform according below values, see table for OMP X and OMR X.

OMR X model	Displacement (cm ³ /rev.)	Min. Torque (Nm)	Min. Rev. (rev./min.)
36	36.9	30	780
50	51.6	43	546
65	64.9	54	435
80	80.3	67	353
100	99.8	83	282
125	124.1	106	225
160	155.4	138	176
200	198.2	173	140

OMR X model	Displacement (cm³/rev.)	Min. Torque (Nm)	Min. Rev. (rev./min.)
250	248.1	216	110
315	310.1	267	89
375	363.5	318	75
400	390.7	333	73
OMP X model	Displacement (cm³/rev.)	Min. Torque (Nm)	Min. Rev. (rev./min.)
25	25	18	1070
32	32	23	840
36	36	26	800
40	40	29	720
50	48.6	36	590
60	59.1	44	486
80	77.8	59	370
100	97.3	75	295
125	125	96	229
160	155.7	124	181
200	194.6	155	145
250	242.3	193	116
315	306.1	248	92
400	389.1	315	72

Check valve

To ensure both check valves is installed correctly, the following test is recommended.

Apply differential pressure at 60 bar \pm 3 bar and turn the shaft 5 RPM.

Test is performed without drain connection.

Motor type	Displacement	Flow max.
OMR X	36	0.9
	50	1.11
	80	1.23
	100	1.31
	125	1.42
	160	1.57
	200	1.74
	250	1.95
	315	2.23
	375	2.47
	400	2.75
Motor type	Displacement	Flow max.
OMP X	25	0.9
	32	1
	36	1
	40	1.06
	50	1.1
	80	1.3
	100	1.3
	125	1.45
	160	1.55
	200	1.72
	250	2.3
	315	2.5
	400	3.3

Chapter

4

Motor identification

Topics:

- *Label side port*
 - *Label end port*
-

Label side port

Place the printed label onto the end cover. Label will contain following information.

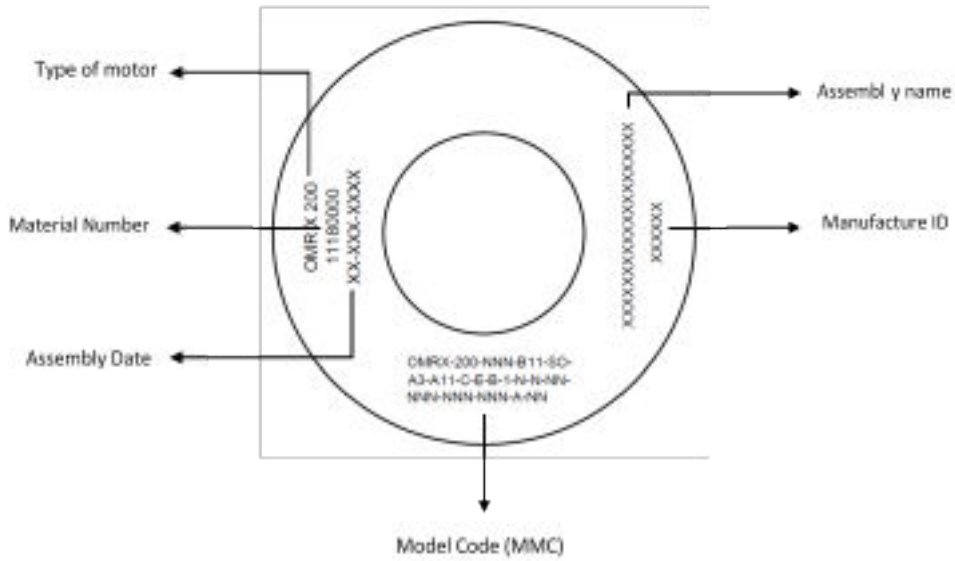

Label end port

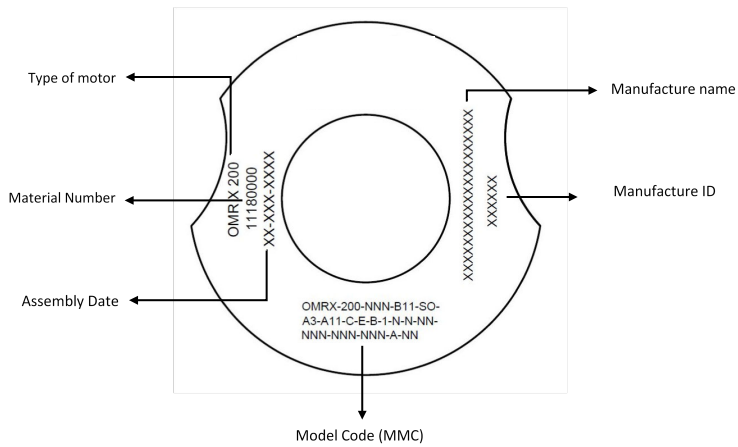

Note: Order label separately. They are not included in the motor modules.

Chapter

5

Packaging

Topics:

- *Motor with $\varnothing 25$ mm and 1 inch shaft*
- *Motor with $\varnothing 28$ mm tapered shaft*
- *Install shipping plugs*
- *Shipment*

Motor with \varnothing 25 mm and 1 inch shaft

After testing, secure the key (pos.34). It should be mounted with a rubber band (pos. 43).

Motor with \varnothing 28 mm tapered shaft

After thoroughly testing the motor, please continue with these steps.

1. Mount the washer (pos. 41) on the output shaft with the chamfer pointing in to the motor housing.
The nut is screwed all the way to the bottom of the threads.
2. Secure the output shaft key (pos. 34) with a rubber band (pos. 43).

Install shipping plugs

Tighten the shipping plugs into place after testing. See required torque in tightening table.

Shipment

Ship assembled motor in supplied box (housing module), and supplied inset (pulp tray).

Chapter

6

Exploded parts list

Topics:

- [Exploded parts list](#)
-

Exploded parts list

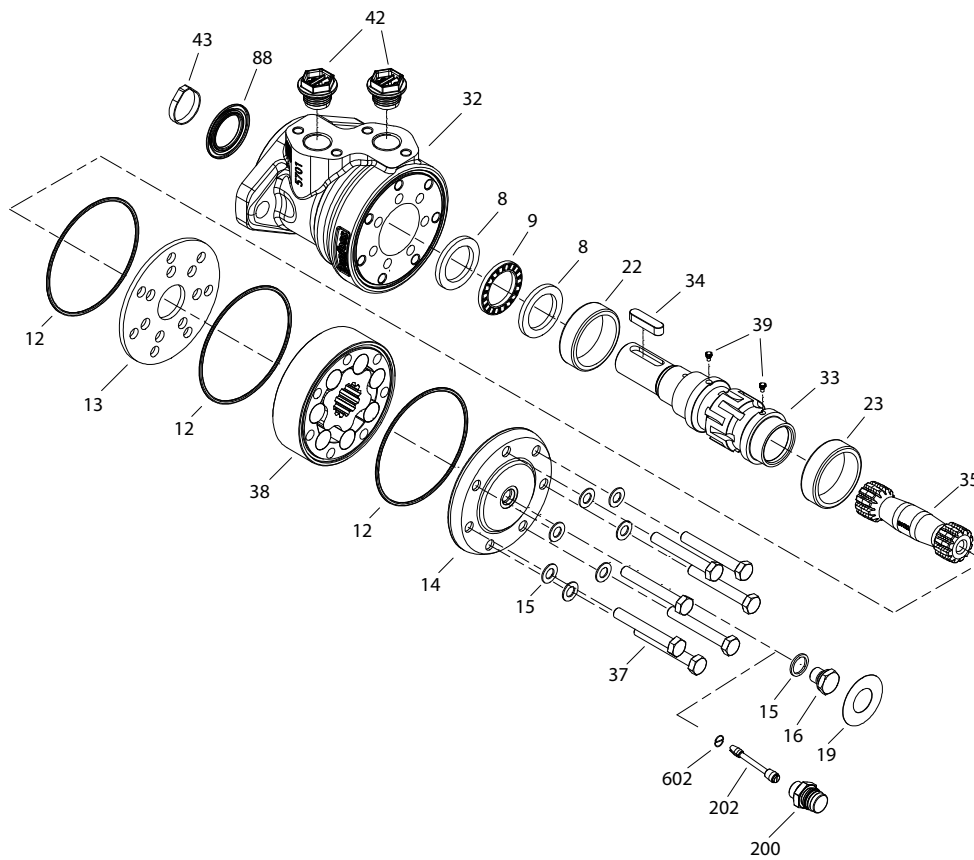

Figure 19: Orbital X Exploded Parts List

Table 3: Orbital X Parts List

Item	Description	Number per unit	Tightening torque
8	Washer	2	-
9	Axial bearing	1	-
12	O-ring	3	-
13	Distributor plate	1	-
14	End cover	1	-
15	Washer	¹	-
16	Drain plug	1	3.5 ± 0.5 N•m [31 ± 4.4 lbf•in]
19	Washer	1	-
22	Needle bearing (front)	1	-

¹ Both Washer (15) and Bolt (37) count vary between models of Orbital X.

Item	Description	Number per unit	Tightening torque
23	Needle bearing (rear)	1	-
32	Housing (shaft seal is installed at the factory)	1	-
33	Spool shaft	1	-
34	Key	1	-
35	Cardan shaft	1	-
37	Bolt	- ¹	45 ± 5 N•m [398.3 ± 44.3 lbf•in]
38	Gear set	1	-
39	Check valve	2	-
42	Plastic plug	2	Finger tight
43	Rubber band	1	-
88	Seal guard	1	-
200	Sensor plug	2	17 N•m [150 lbf•in] ± 2.5 N•m [22 lbf•in]
202	EMD shaft	1	-
602	S-springs	1	-

Chapter

7

Additional tools needed

Topics:

- *Additional tools needed*
-

Additional tools needed

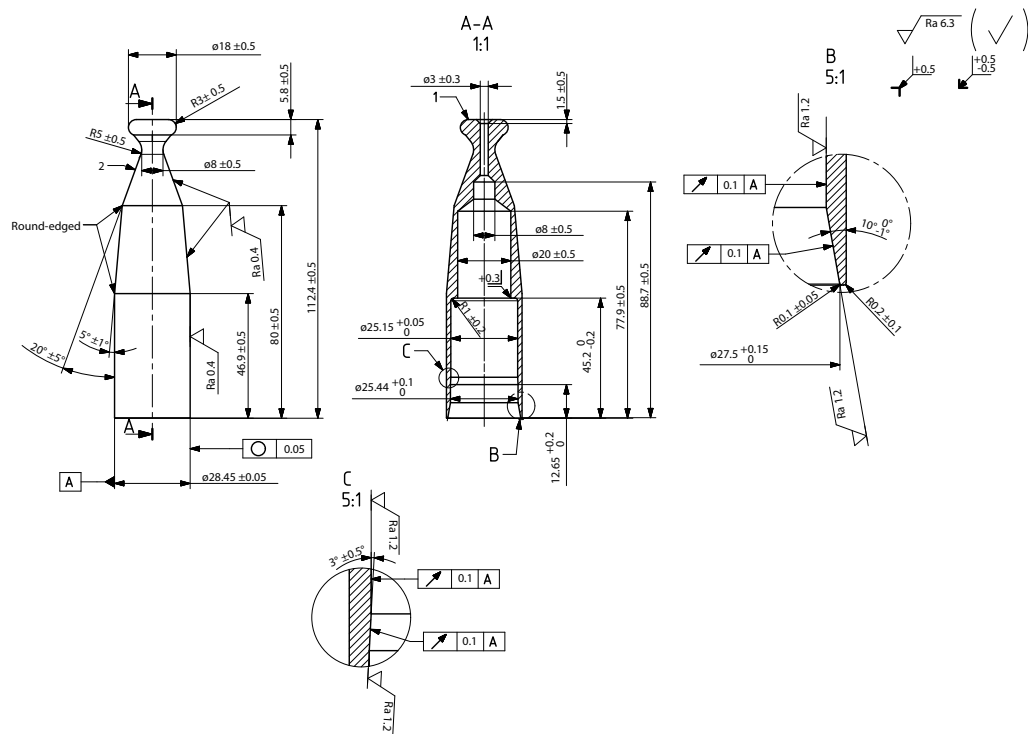

Figure 20: Torpedo for 1 in tapered shaft

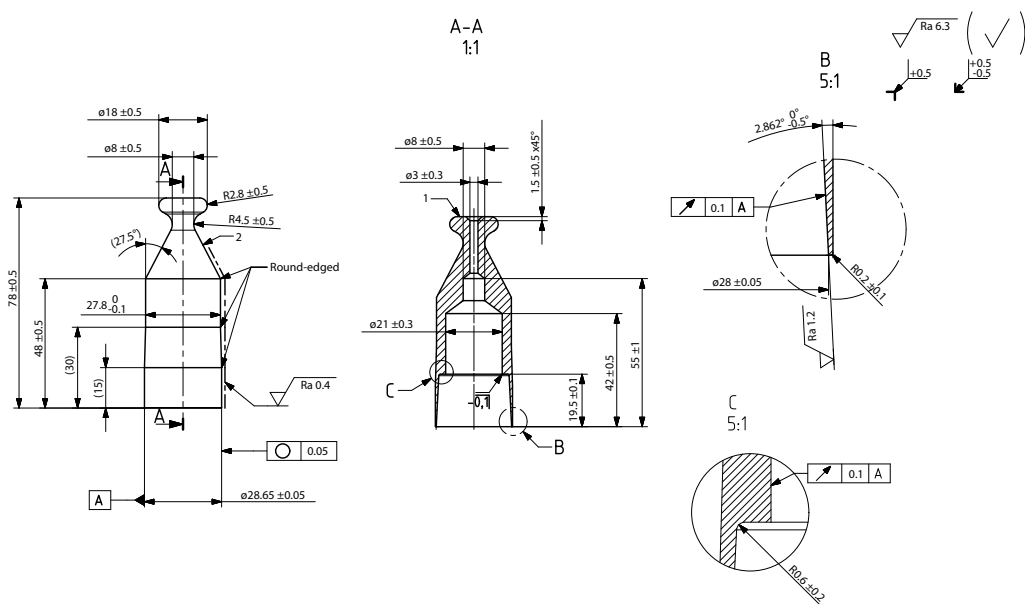

Figure 21: Torpedo for 28, 56 tapered shaft

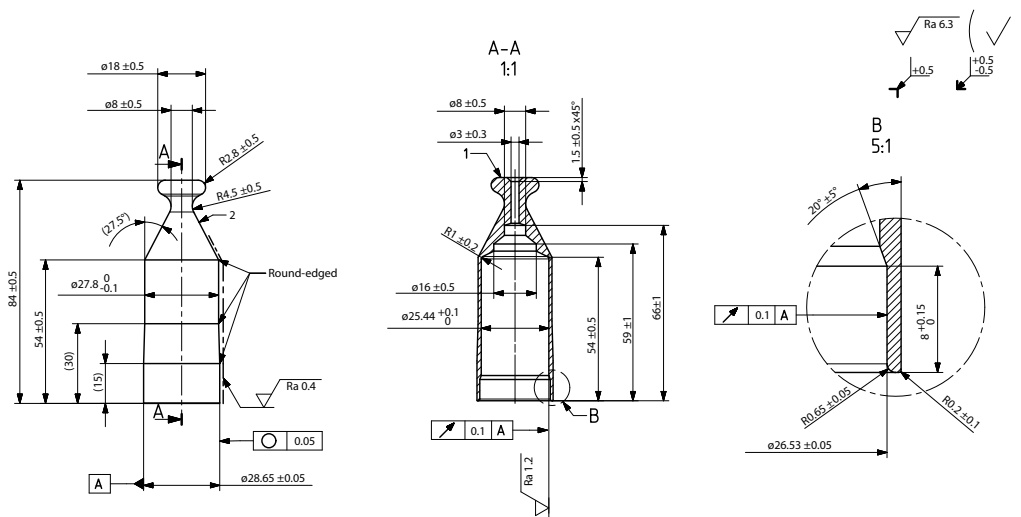

Figure 22: Torpedo for cylindrical long shaft

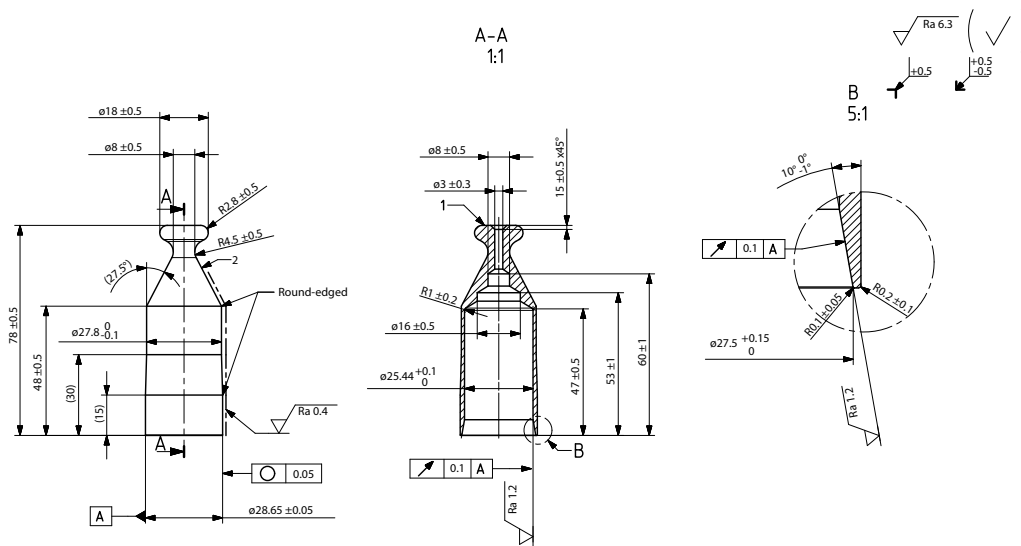

Figure 23: Torpedo for 25mm, 1 in., and 7/8 splined shaft

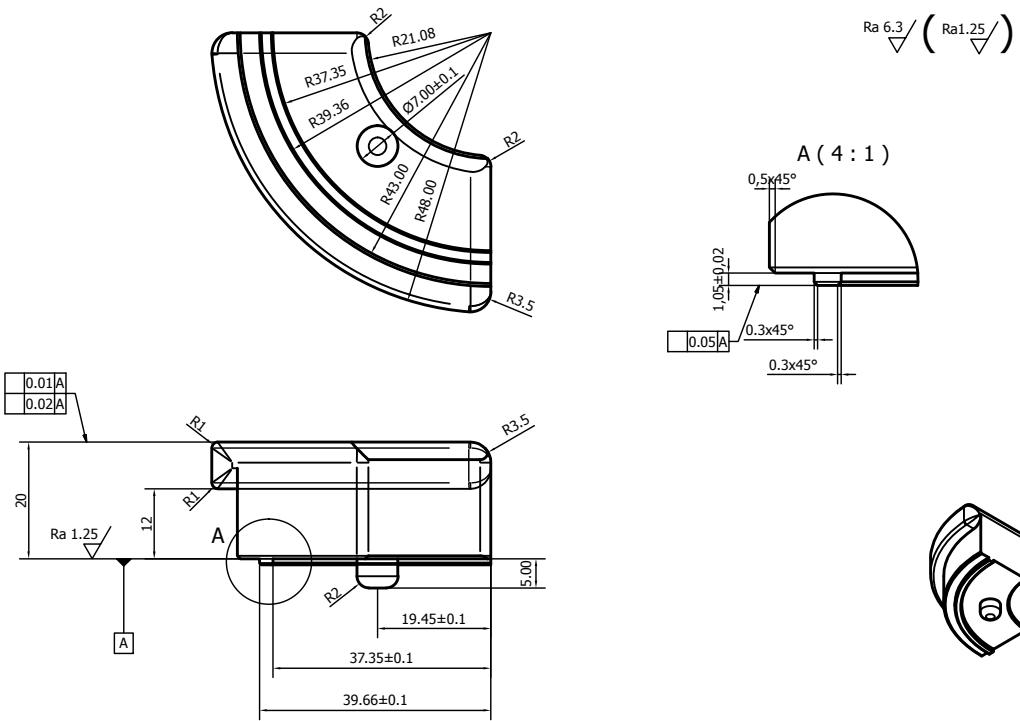

Figure 24: OMP check valve sleeve

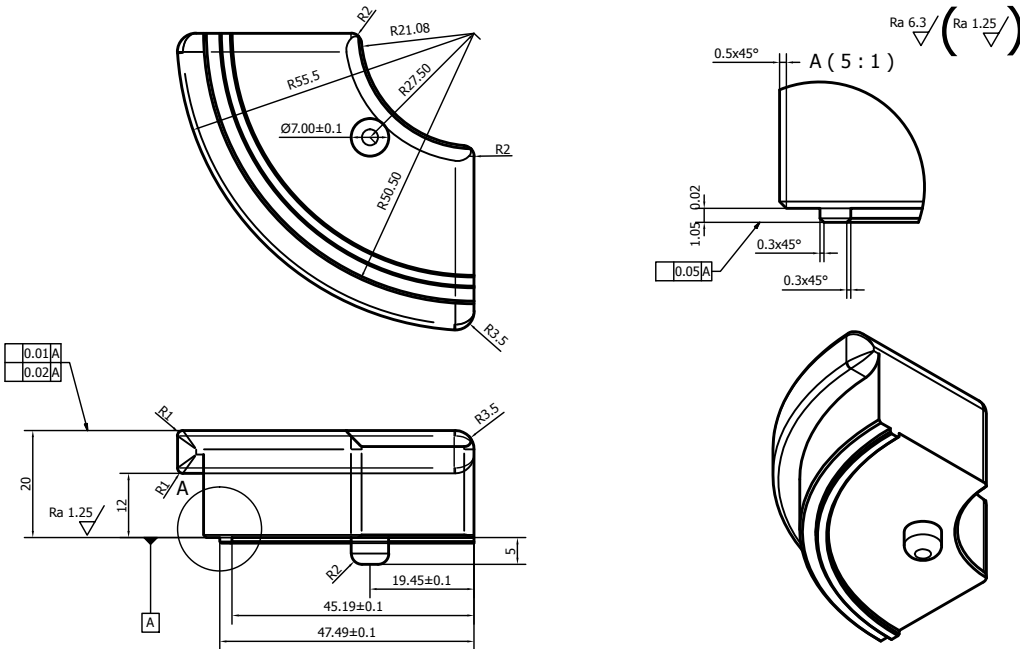
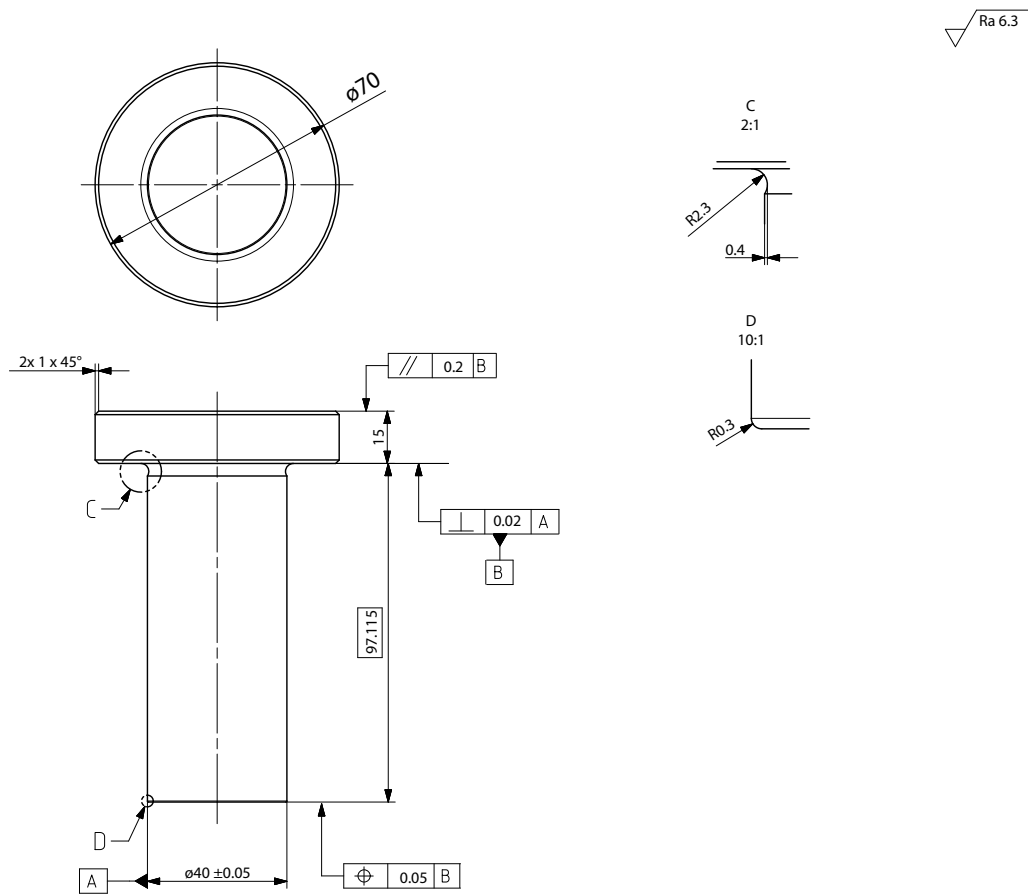
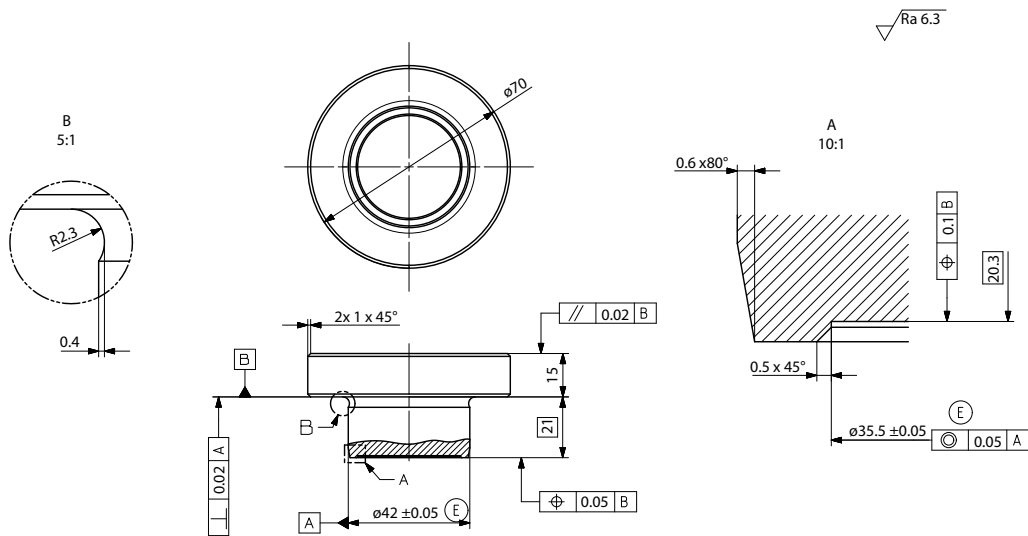

Figure 25: OMR check valve sleeve



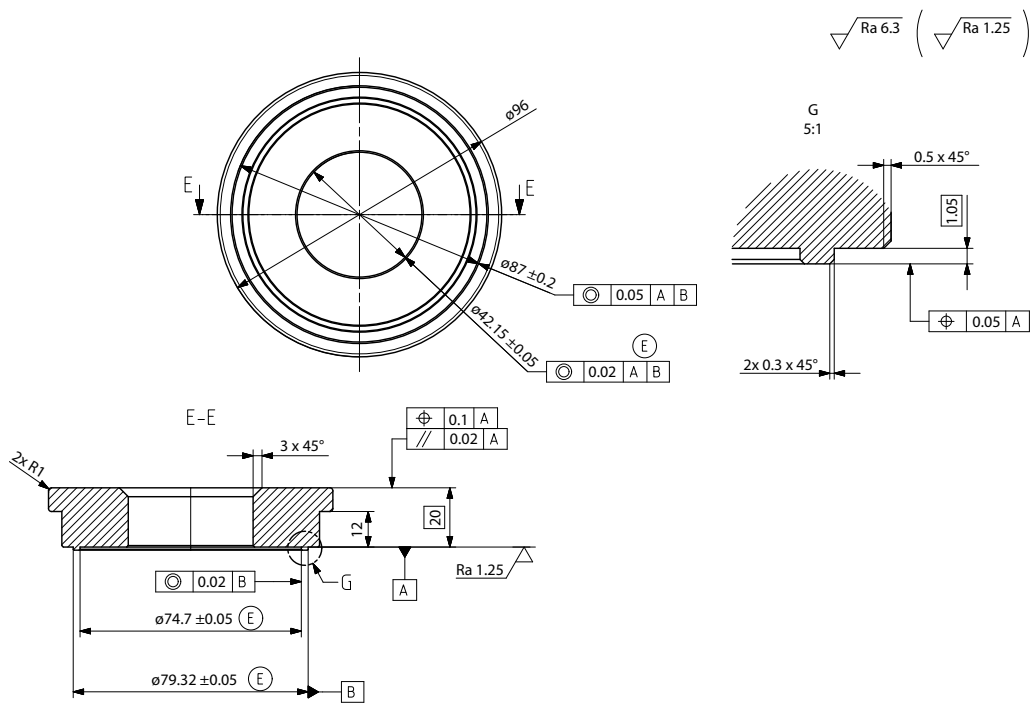

Figure 28: Pressing tool for needle bearing (3 of 4) - OMP center plate

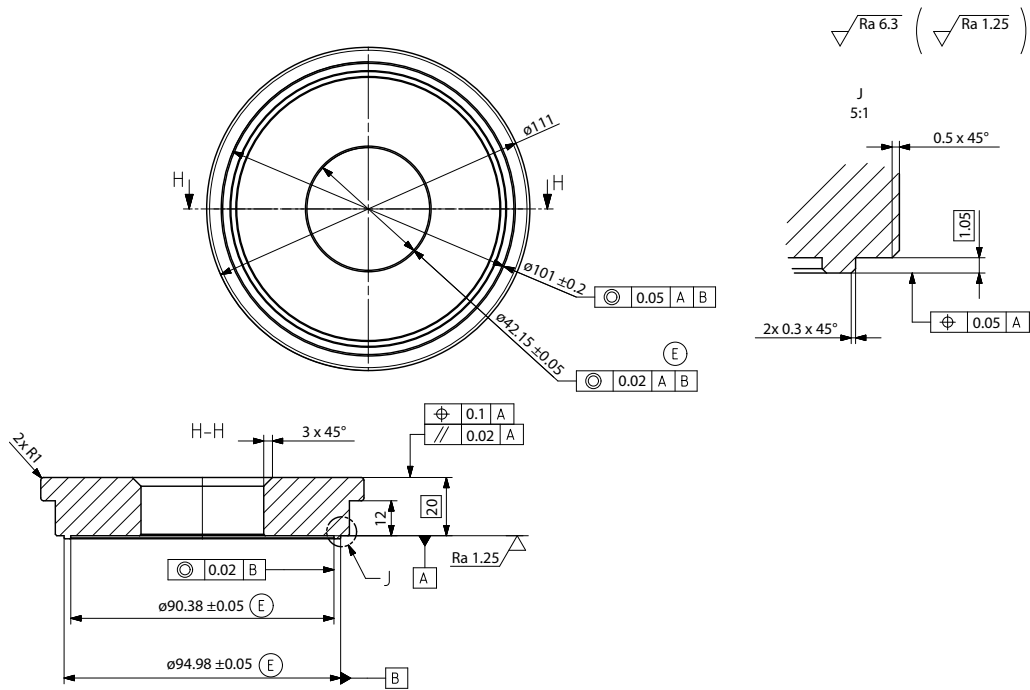

Figure 29: Pressing tool for needle bearing (4 of 4) - OMR center plate

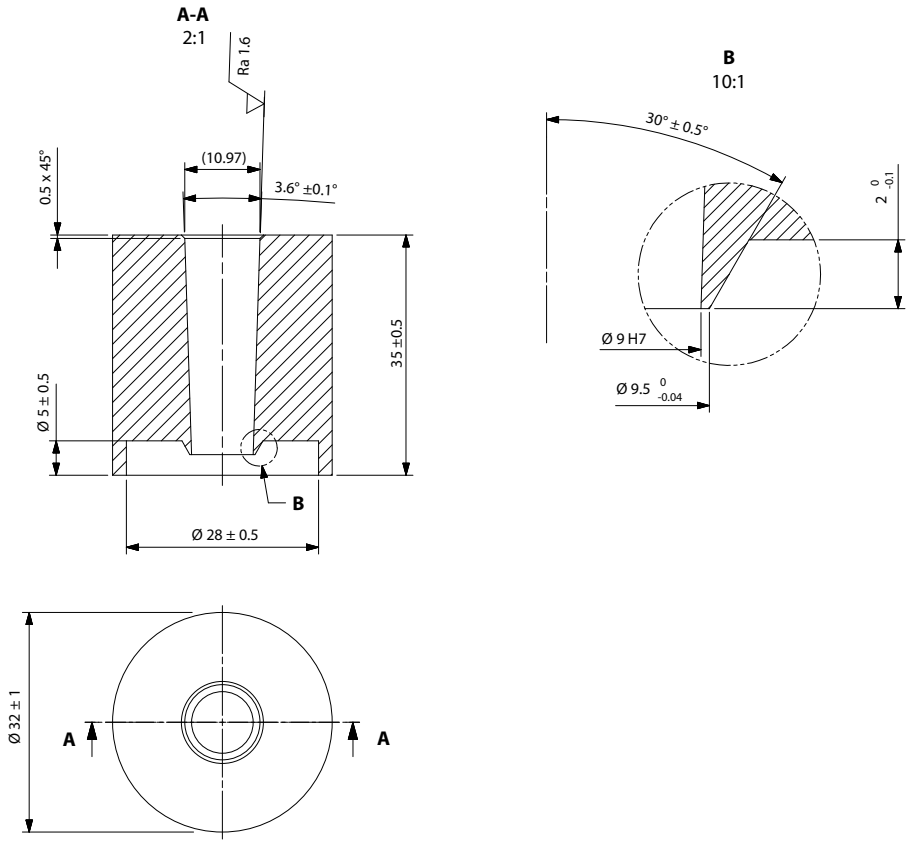

Figure 30: S-spring fixture (1 of 3)

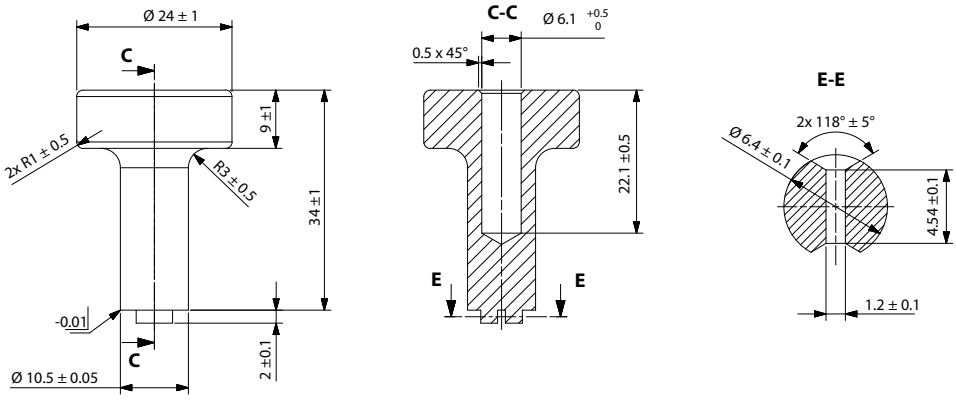

Figure 31: S-spring fixture (2 of 3)

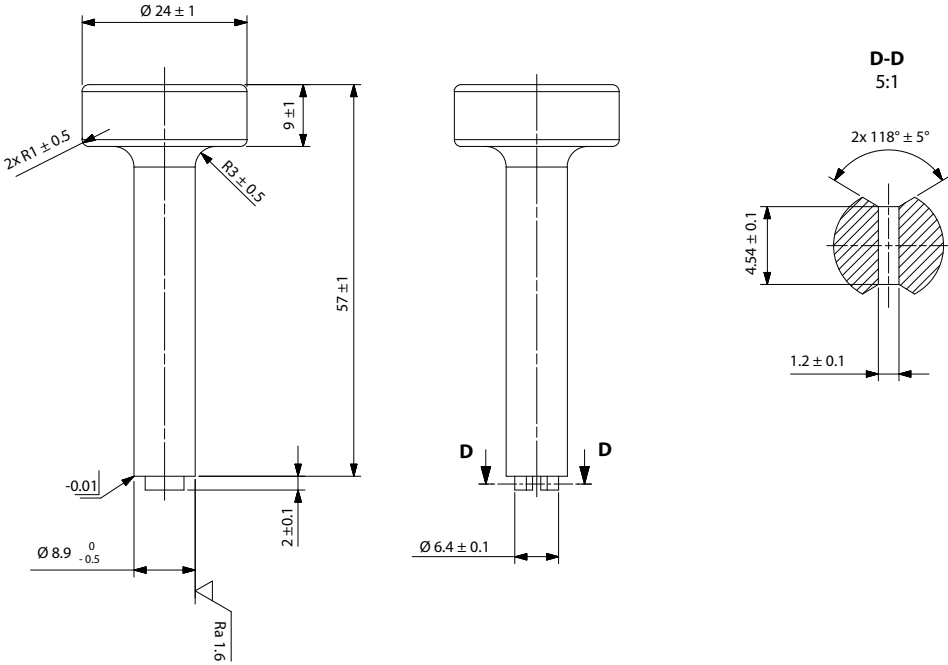

Figure 32: S-spring fixture (3 of 3)

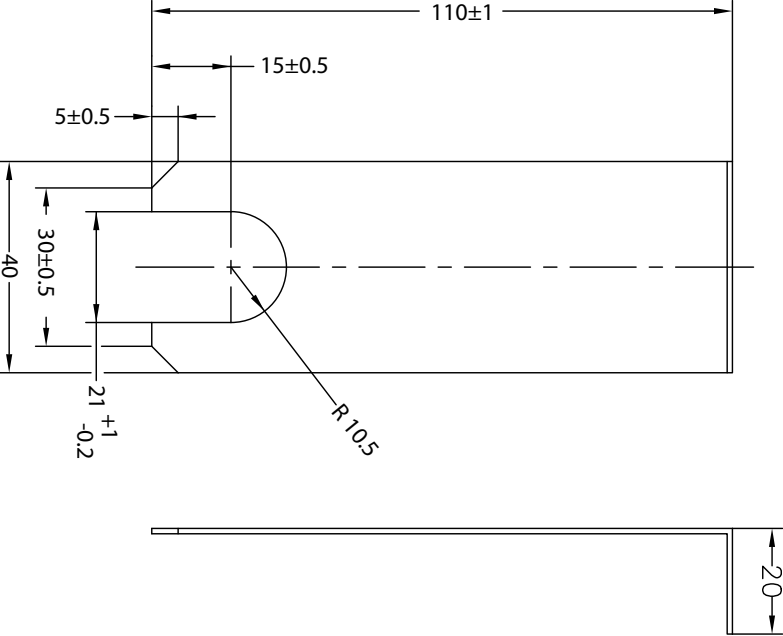

Figure 33: Fork

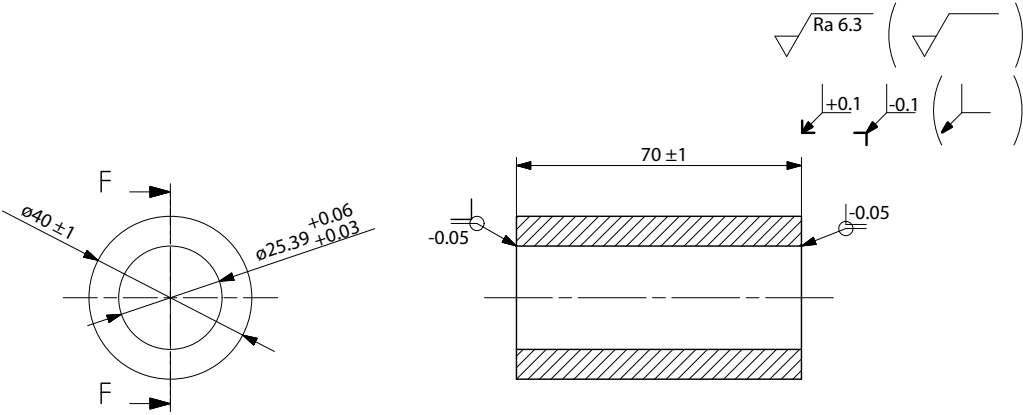

Figure 34: Pressing tool for Seal guard

Chapter

8

Tightening table

Topics:

- [Tightening table](#)

Tightening table

Pos. no.	Part no.	Description	Cross-tightened?	Tightening torque Nm [lbf*in]
37	Multiple	Screw	Yes	32.5 [288] ±2.5 [22]
42	11149420	Plug plastic G1/2	No	3.5 [31] ± 1.5 [13]
42	11149426	Plug plastic M22x1.5	No	3.5 [31] ± 1.5 [13]
42	11149429	Plug plastic ½-14 NPTH	No	3.5 [31] ± 1.5 [13]
42	11149433	Plug plastic 7/8-14 UNF	No	3.5 [31] ± 1.5 [13]
42	633X0153	Cap	No	(No thread) Assembly by hand
16	631X2019	Drain plug M12x1.5	No	30 [266] ± 2 [18]
16	151-1524	Drain plug G1/4	No	38 [336] ± 6 [53]
16	151-5439	Drain plug 7/16-20 UNF	No	38 [336] ± 6 [53]
200	11141412	Sensor plug G1/4	No	17 [150] ± 2.5 [22]
20	631X9706	Plug steel G1/2	No	60 [531] ± 10 [89]
40	681X8202	Nut M20	No	Not specified (Tightened by fingers)
40	681X0072	Nut ¾ UNF	No	Not specified (Tightened by fingers)