

Repair Instruction Orbital Motor DH and DS Series 1



OIL SOLUTIONS

PO Box 38

Strathfieldsaye, VIC, 3551

1800 OIL SOL

1800 645 765

sales@oilsolutions.com.au

www.oilsolutions.com.au

"For All Your Hydraulic Needs"

Contents

Chapter 1: Safety Precautions.....	5
Safety precautions.....	6
Chapter 2: Special versions.....	7
DH and DS special versions.....	8
Cost-free repairs.....	8
DH series 1 with integrated spigot flange.....	8
DS series 1 with integrated spigot flange.....	8
Chapter 3: Exploded views.....	9
DH exploded view.....	10
Chapter 4: Spare part list.....	11
DH spare part list.....	12
Chapter 5: Exploded views.....	15
DS exploded view.....	16
Chapter 6: Spare part list.....	17
DS spare part list.....	18
Chapter 7: Dismantling / Cleaning.....	21
Dismantling DH / DS.....	22
Cleaning.....	22
Chapter 8: Assembling.....	23
DH/DS assembling.....	24
Chapter 9: Special tools.....	27
Special tools.....	28

Chapter

1

Safety Precautions

Topics:

- [Safety precautions](#)

Safety precautions

Always consider safety precautions before beginning a service procedure. Protect yourself and others from injury. Take the following general precautions whenever servicing a hydraulic system.



Warning:

Unintended vehicle or machine movement hazard.

Unintended movement of the machine or mechanism may cause injury to the technician or bystanders. To prevent unintended movement, secure the machine or disable/disconnect the mechanism while servicing.



Warning:

Flammable cleaning solvents

Some cleaning solvents are flammable. To eliminate the risk of fire, do not use cleaning solvents in an area where a source of ignition may be present.



Warning: Fluid under pressure

Escaping hydraulic fluid under pressure can have sufficient force to penetrate your skin causing serious injury and/or infection. This fluid may also be hot enough to cause burns. Use caution when dealing with hydraulic fluid under pressure. Relieve pressure in the system before removing hoses, fittings, gauges, or components. Never use your hand or any other body part to check for leaks in a pressurized line. Seek medical attention immediately if you are cut by hydraulic fluid.



Warning:

Personal safety

Protect yourself from injury. Use proper safety equipment, including safety glasses at all times.

Chapter

2

Special versions

Topics:

- *DH and DS special versions*
 - *Cost-free repairs*
 - *DH series 1 with integrated spigot flange*
 - *DS series 1 with integrated spigot flange*
-

DH and DS special versions

The list of spare parts cannot be used when ordering parts for special DH and DS versions.

In this respect, please contact the sales organisation.

Cost-free repairs

We would point out that cost-free repairs as mentioned in General Conditions of Sale, are carried out only at service shops authorized by the organization.

DH series 1 with integrated spigot flange

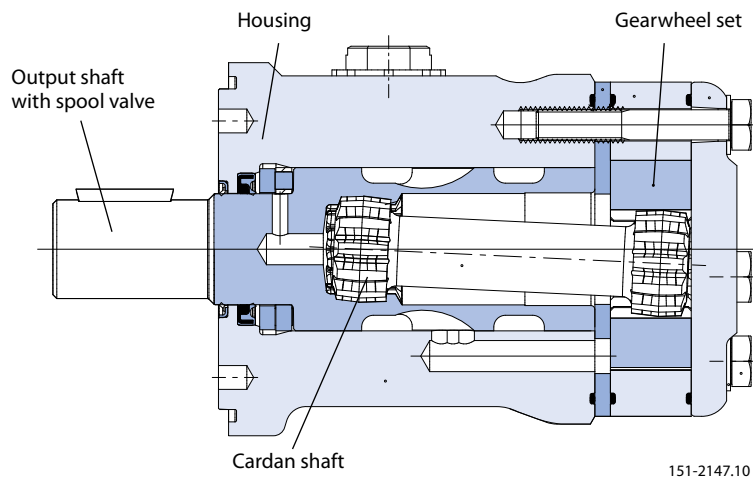

DS series 1 with integrated spigot flange

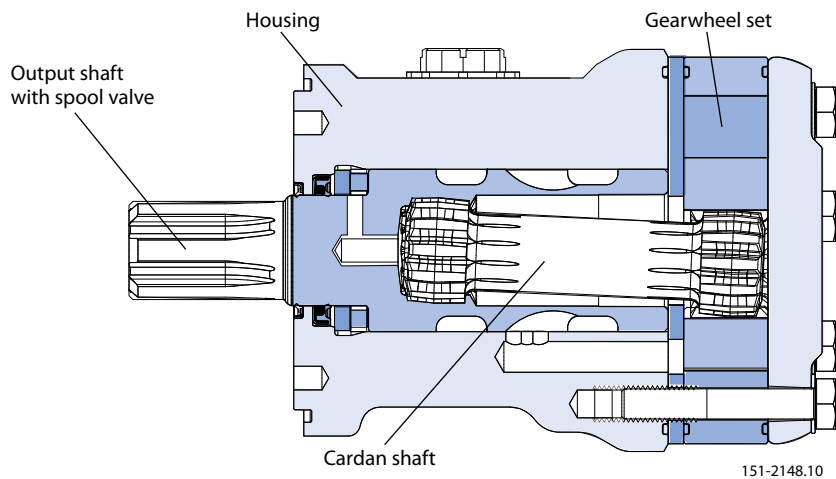

Chapter

3

Exploded views

Topics:

- [DH exploded view](#)
-

DH exploded view

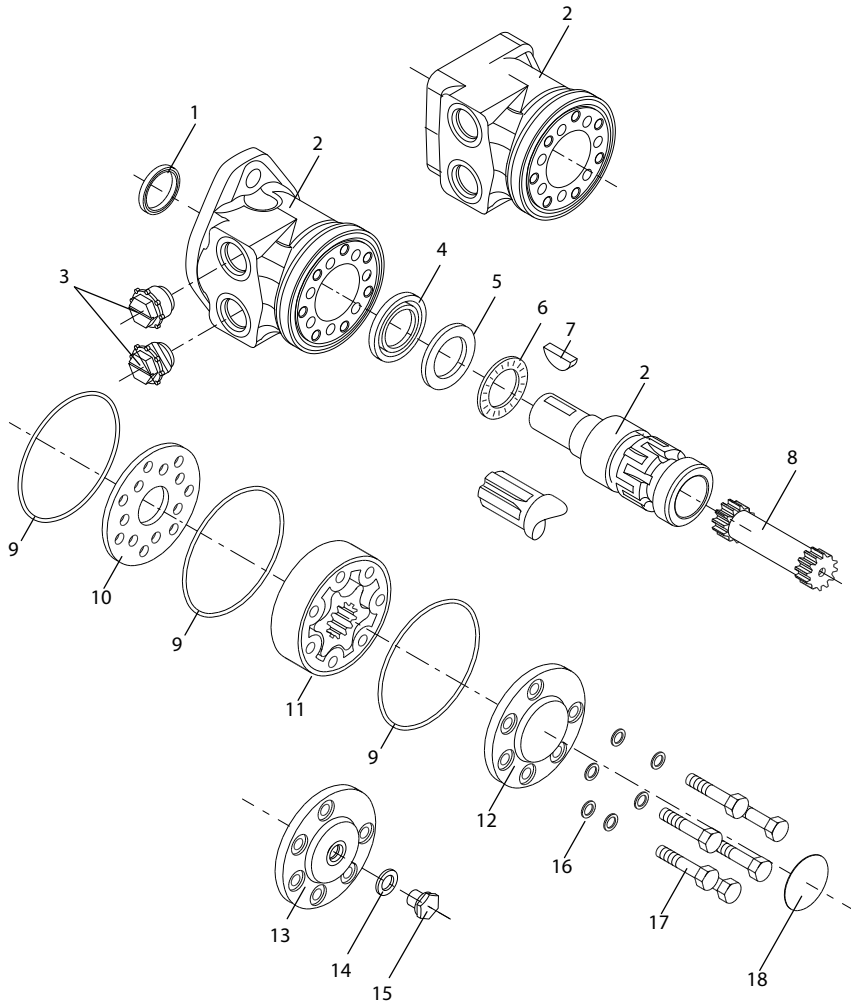

151-2145.10

Chapter

4

Spare part list

Topics:

- [DH spare part list](#)

DH spare part list

Item	Spare parts	Dimensions	Code No	Number per motor
1	Dust seal ring	28.56 × 35.00 × 2.20 [1.25 × 1.38 × 0.09]	633B0370	1
2	Housing and output shaft			
3	Plug (plastic)	7/8-14 UNF	633X0017	2
		1/2 - 14 NPTF	11042922	2
		Manifold	11043191	2
4	Shaft seal	28.56 × 39.00 × 4.57 [1.25 × 1.54 × 0.18]	633B0361	1
5	Bearing race		11043824	1
6	Axial needle bearing		11043825	1
7	Woodruff key	1/4 × 7/16 × 1	682L9054	1
8	Cardan shaft			
	DH 36	L = 76.8 mm [3.02 in]	11041237	1
	DH 50	L = 76.8 mm [3.02 in]	11041237	1
	DH 80	L = 80.7 mm [3.18 in]	11041239	1
	DH 100	L = 83.3 mm [3.28 in]	11041238	1
	DH 125	L = 87.1 mm [3.42 in]	11041240	1
	DH 160	L = 91.2 mm [3.59 in]	11041242	1
	DH 200	L = 96.4 mm [3.80 in]	11041244	1
	DH 250	L = 102.9 mm [4.05 in]	11041247	1
	DH 315	L = 111.4 mm [4.39 in]	11041246	1
	DH 400	L = 122.6 mm [4.83 in]	11041243	1
9	O-ring	75.9 × 1.8 mm	633B1173	3
10	Distributor plate		151-1713	1

Item	Spare parts	Dimensions	Code No	Number per motor
11	Gearwheel set			
	DH 36	w = 5.9 mm [0.23 in]	151-1258	1
	DH 50	w = 6.5 mm [0.26 in]	151-1126	1
	DH 80	w = 10.4 mm [0.41 in]	151-1127	1
	DH 100	w = 13.0 mm [0.51 in]	151-1128	1
	DH 125	w = 16.3 mm [0.64 in]	151-1112	1
	DH 160	w = 20.8 mm [0.82 in]	151-1129	1
	DH 200	w = 26.0 mm [1.02 in]	151-1185	1
	DH 250	w = 32.5 mm [1.28 in]	151-1193	1
	DH 315	w = 40.9 mm [1.61 in]	151-1186	1
	DH 400	w = 52.0 mm [2.05 in]	151-1187	1
12	Endcover without drainport		151-2673	1
13	Endcover with drainport	7/16-20 UNF	151-2641	1
14	Washer		684X0115	1
15	Plug	7/16-20 UNF	151-5439	1
16	Washer	8.2 × 15.2 × 1	684X0115	6
17	Screw M8 × 1.25 mm			
	DH 36	L = 35 mm [1.38 in]	681X0179	6
	DH 50	L = 35 mm [1.38 in]	681X0179	6
	DH 80	L = 40 mm [1.57 in]	681X0180	6
	DH 100	L = 40 mm [1.57 in]	681X0180	6
	DH 125	L = 45 mm [1.77 in]	681X0181	6
	DH 160	L = 50 mm [1.97 in]	681X0182	6
	DH 200	L = 55 mm [2.17 in]	681X0183	6
	DH 250	L = 60 mm [2.36 in]	681X0184	6
	DH 315	L = 70 mm [2.76 in]	681X0186	6
	DH 400	L = 80 mm [3.15 in]	681X0188	6
18	Name plate			1

Chapter

5

Exploded views

Topics:

- *DS exploded view*
-

DS exploded view

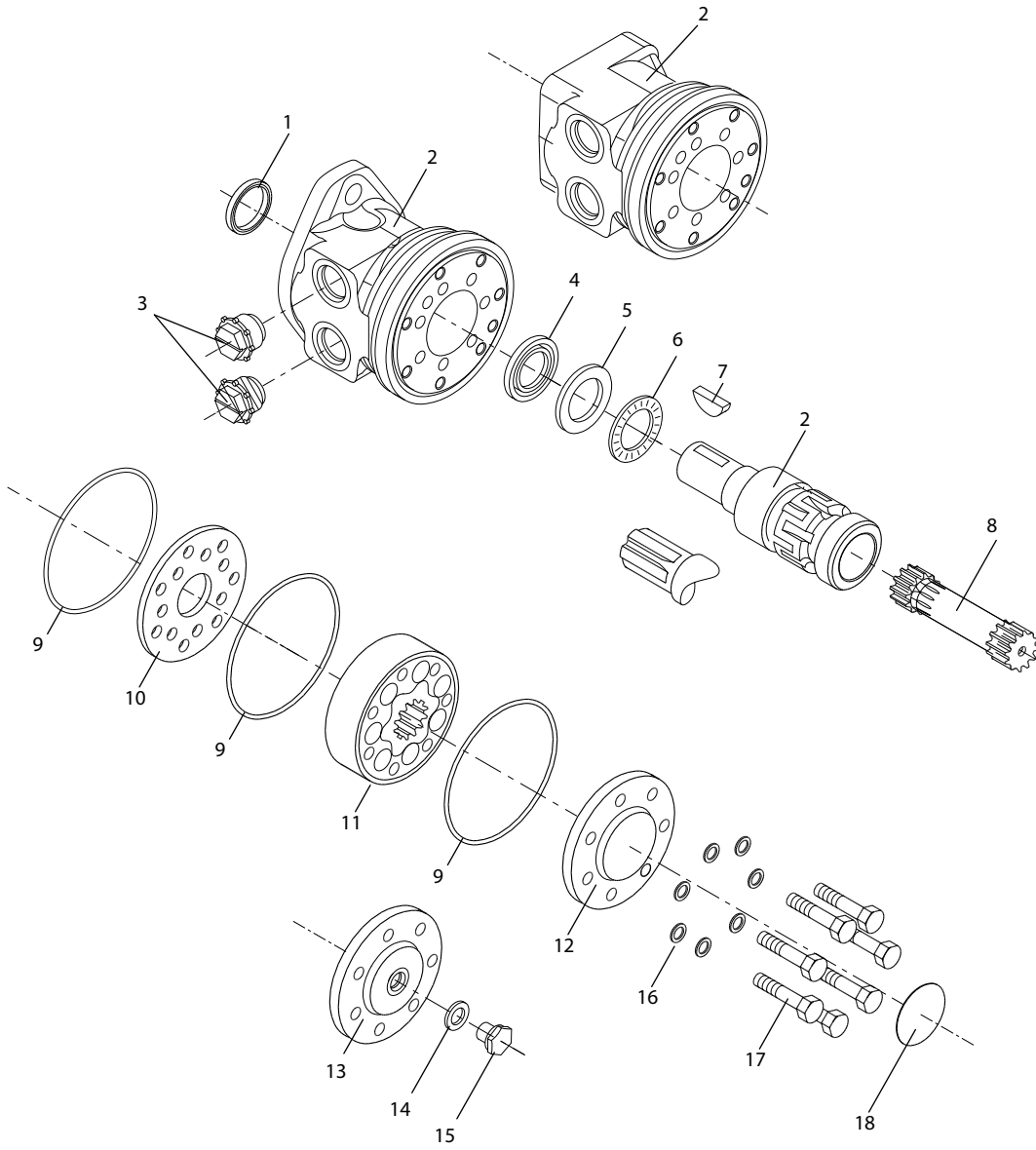

151-2146.10

Chapter

6

Spare part list

Topics:

- [DS spare part list](#)

DS spare part list

Item	Spare part	Dimensions	Code numbers	Number per motor
1	Dust seal ring	28.56 × 35.00 × 2.20 [1.25 × 1.38 × 0.09]	633B0370	1
2	Housing and output shaft			
3	Plug (plastic)	7/8-14 UNF	633X0017	2
		1/2 - 14 NPTF	11042922	2
		Manifold	11043191	2
4	Shaft seal	28.56 × 39.00 × 4.57 [1.25 × 1.54 × 0.18]	633B0361	1
5	Bearing race		11043824	1
6	Axial needle bearing		11043825	1
7	Woodruff key	1/4 × 7/16 × 1	682L9054	1
8	Cardan shaft			
	DS 50	L = 80.0 mm [3.15 in]	11046260	1
	DS 80	L = 85.0 mm [3.35 in]	11046261	1
	DS 100	L = 85.0 mm [3.35 in]	11046261	1
	DS 125	L = 88.3 mm [3.48 in]	11046283	1
	DS 160	L = 92.7 mm [3.65 in]	11046284	1
	DS 200	L = 98.8 mm [3.89 in]	11046285	1
	DS 250	L = 105.8 mm [4.17 in]	11046286	1
	DS 315	L = 114.5 mm [4.51 in]	11046287	1
	DS 375	L = 129.9 mm [5.51 in]	11046288	1
9	O-ring	90 × 2 mm	633B1301	3
10	Distributor plate		151-1702	1

Item	Spare part	Dimensions	Code numbers	Number per motor
11	Gearwheel set			
	DS 50	w = 9.0 mm [0.35 in]	151-1182	1
	DS 80	w = 14.0 mm [0.55 in]	151-1138	1
	DS 100	w = 14.0 mm [0.55 in]	151H2102	1
	DS 125	w = 17.6 mm [0.69 in]	151H2103	1
	DS 160	w = 21.7 mm [0.85 in]	151H2104	1
	DS 200	w = 27.8 mm [1.09 in]	151H2105	1
	DS 250	w = 34.8 mm [1.37 in]	151H2106	1
	DS 315	w = 43.5 mm [1.71 in]	151H2107	1
	DS 375	w = 54.8 mm [2.16 in]	151H2108	1
12	Endcover without drainport		151-5568	1
13	Endcover with drainport	7/16-20 UNF	151-1731	1
14	Washer		684X0115	1
15	Plug	7/16-20 UNF	151-5439	1
16	Washer	8.2 × 15.2 × 1	684X0115	7
17	Screw M8 × 1.25 mm			
	DS 50	L = 40 mm [1.57 in]	681X0180	7
	DS 80	L = 45 mm [1.77 in]	681X0181	7
	DS 100	L = 45 mm [1.77 in]	681X0181	7
	DS 125	L = 45 mm [1.77 in]	681X0181	7
	DS 160	L = 50 mm [1.97 in]	681X0182	7
	DS 200	L = 55 mm [2.17 in]	681X0183	7
	DS 250	L = 65 mm [2.56 in]	681X0185	7
	DS 315	L = 75 mm [2.95 in]	681X0187	7
	DS 375	L = 85 mm [3.35 in]	681X0189	7
18	Name plate			1

Chapter

7

Dismantling / Cleaning

Topics:

- *Dismantling DH / DS*
 - *Cleaning*
-

Dismantling DH / DS

Item	Part to remove	Comments
7	Woodruff key	
3	Seal plugs	Put the motor in a holding tool, with the output shaft downward
14, 15	Drain plug, washer (if present)	Use a 17 mm spanner socket.
16, 17	Screws, washers	Use a 13 mm spanner socket.
12	End cover	Remove end cover sideways
9, 11	Gear wheel set, O-rings (2 off)	Keep fingers under the gearwheel set to prevent the parts from falling out
8	Cardan shaft	
9, 10	Distributor plate, O-ring	
2	Output shaft	Place the motor housing on the work bench and press the shaft out of the motor housing. After this, turn the motor
5, 6	O-ring, bearing race	Remove bearing and bearing race from the motor housing
5	Shaft seal	With mandrel and plastic hammer, carefully knock out the shaft seal
3	Dust seal	

Cleaning

Cleaning

Clean all parts carefully with low aromatic kerosine.

Inspection and replacement

Check all parts carefully and replace if necessary.

Lubrication

Before assembly, lubricate all parts with hydraulic oil and grease rubber parts with vaseline.

Chapter

8

Assembling

Topics:

- *DH/DS assembling*
-

DH/DS assembling

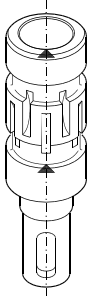
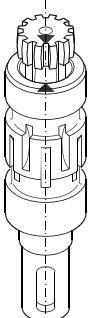
Item	Part to remove	Comments
		Place the motor housing in the holding tool with the flange upwards
4	Shaft seal	Lubricate the shaft seal on the outside with hydraulic oil. Fit the shaft seal correctly onto mandrel SJ 151-0414 and carefully press the shaft seal into position in the motor housing
1	Dust seal ring	Place the dust seal ring in the spigot flange and knock it into position with a plastic hammer and appropriate mandrel. SJ 151-9000-7 or SJ 151F9000-7
5, 6	Bearing race	Fit bearing and bearing race onto the shaft and mount together with the shaft
2	Output shaft	<i>Grease the journals with hydraulic oil.</i> The rear shaft end must be marked before fitted. The mark must be positioned vertically above a commutation slot leading up to the front annular channel
		
	151-1572.10	
9	O-ring	Grease the O-ring and put it in the O-ring groove of the housing
10	Distributor plate	Turn the distributor plate so that the holes line up
8	Cardan shaft	Guide the cardan shaft down into the motor housing. Only DH 36 and 50. Place the assembly tool under the upper splines of the cardan shaft. In case of different splines lengths turn the cardan shaft to ensure the long splines end is fitted in the output shaft. Transfer marking from output shaft to cardan shaft.
		
	151-1571.10	

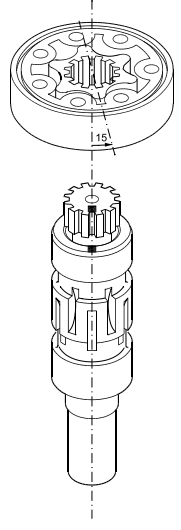
Item	Part to remove	Comments
9, 11	Gearwheel set 	<p>Place the O-rings (greased) in the O-ring grooves of the gearwheel.</p> <p>In gearwheels with non through splines place the gearwheel with the recess in the spline hole facing down towards the housing.</p> <p>Place the gearwheel set on the cardan shaft so that the top of a tooth in the external teeth of the gearwheel is vertically above the mark on the cardan shaft.</p> <p>Turn the gearwheel set counter clockwise until the cardan shaft and the gearwheel start to mesh (15°). Turn the gearwheel rim so that the holes made for the screws line up.</p>
12	End cover	Turn the end cover so that the holes line up
16, 17	Washer, screws	Use a 13 mm spanner socket Tightening torque: 30 - 35 N•m [265-310 lbf•in]
14, 15	Washer, drain plug	Use a 17 mm spanner socket. Tightening torque: 32 - 44 N•m [283-389 lbf•in]
3	Seal plugs Threaded plug (if present)	Screw in plastic plugs
7	Woodruff key	To be secured with tape or plastic ring

Chapter 9

Special tools

Topics:

- *Special tools*
-

Special tools

Main holding tool (horse hole): Code No.: SJ 151-9000-1.



F300 083

Fork. For use when fitting cardan shaft. Code No.: SJ 151-9000-3.

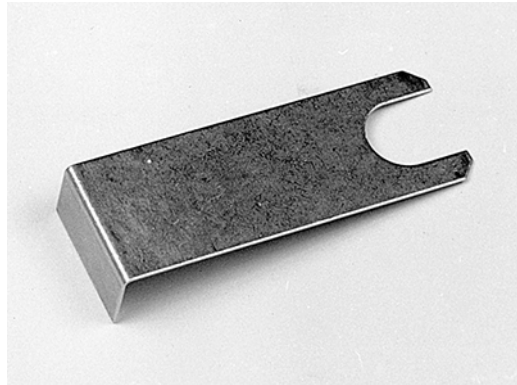

F300 945

Mandrel: Code No.: SJ 151-0414

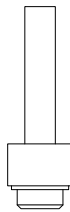

151-2097.10_a

Holding tool for motor with square mounting flange: Code No.: SJ 151-9000-12

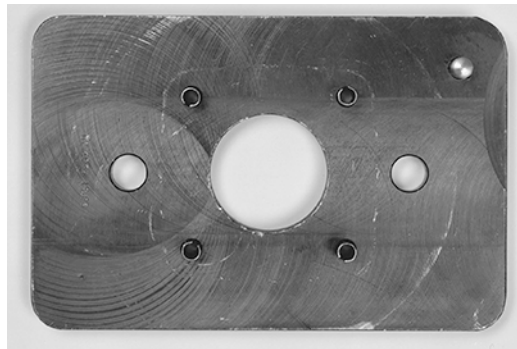

F300 131