

Technical Information

# Orbital Motors DH and DS

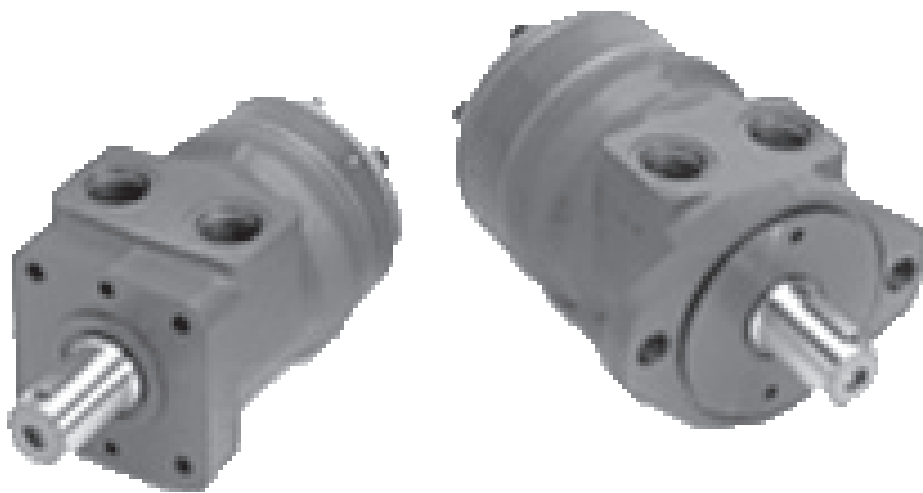

1800-OILSOL  
1800-645765

<https://oilsolutions.com.au/>

[sales@oilsolutions.com.au](mailto:sales@oilsolutions.com.au)

Contents

**DH and DS Orbital Motor Data Survey** ..... 3  
 Speed, Torque and Output ..... 3

**DH** ..... 4  
 Versions ..... 4  
 Code Numbers ..... 5  
 Technical Data ..... 6  
     Technical Data for DH with 1 in Cylindrical and 1 in-6b Splined Shaft ..... 6  
 Max. Permissible Shaft Seal Pressure ..... 7  
 Pressure Drop in Motor ..... 7  
 Oil Flow in Drain Line ..... 8  
 Direction of Shaft Rotation ..... 8  
 Permissible Shaft Loads for DH ..... 9  
 Function Diagrams ..... 10  
 Shaft Version ..... 15  
 Port Thread Versions ..... 16  
 Dimensions ..... 17  
     Dimensions – US Version ..... 17

**DS** ..... 20  
 Versions ..... 20  
 Code Numbers ..... 21  
 Technical Data ..... 22  
     Technical data for DS with 1 in cylindrical and 1 in-6b splined shaft ..... 22  
 Max. Permissible Shaft Seal Pressure ..... 23  
 Pressure Drop in Motor ..... 23  
     Max. permissible shaft seal pressure ..... 23  
 Oil Flow in Drain Line ..... 24  
 Direction of Shaft Rotation ..... 24  
 Permissible Shaft Loads for DS ..... 25  
 Function Diagrams ..... 26  
 Shaft Version ..... 31  
 Port Thread Versions ..... 32  
 Dimensions ..... 33  
     Dimensions – US Version ..... 33

**Hydraulic Systems** ..... 36  
 Installation of the Orbital Motors ..... 36  
 Starting Up and Running in the Hydraulic System ..... 36  
 Operation ..... 36  
 Maintenance ..... 36

**Weight of Motors** ..... 37

**Speed, Torque and Output**

The bar diagrams, see page 5, are useful for a quick selection of relevant motor size for the application. The final motor size can be determined by using the function diagram for each motor size.

- DH can be found on pages 12-16
- DS can be found on pages 28-32

The function diagrams are based on actual tests on a representative number of motors from our production. The diagrams apply to a return pressure between 5 and 10 bar [75 and 150 psi] when using mineral based hydraulic oil with a viscosity of 35 mm<sup>2</sup>/s [165 SUS] and a temperature of 50°C [120°F]. For further explanation concerning how to read and use the function diagrams, please consult the paragraph "Selection of motor size" in the technical information "General" 520L0232.

DH and DS Orbital Motor Data Survey

Speed, Torque and Output

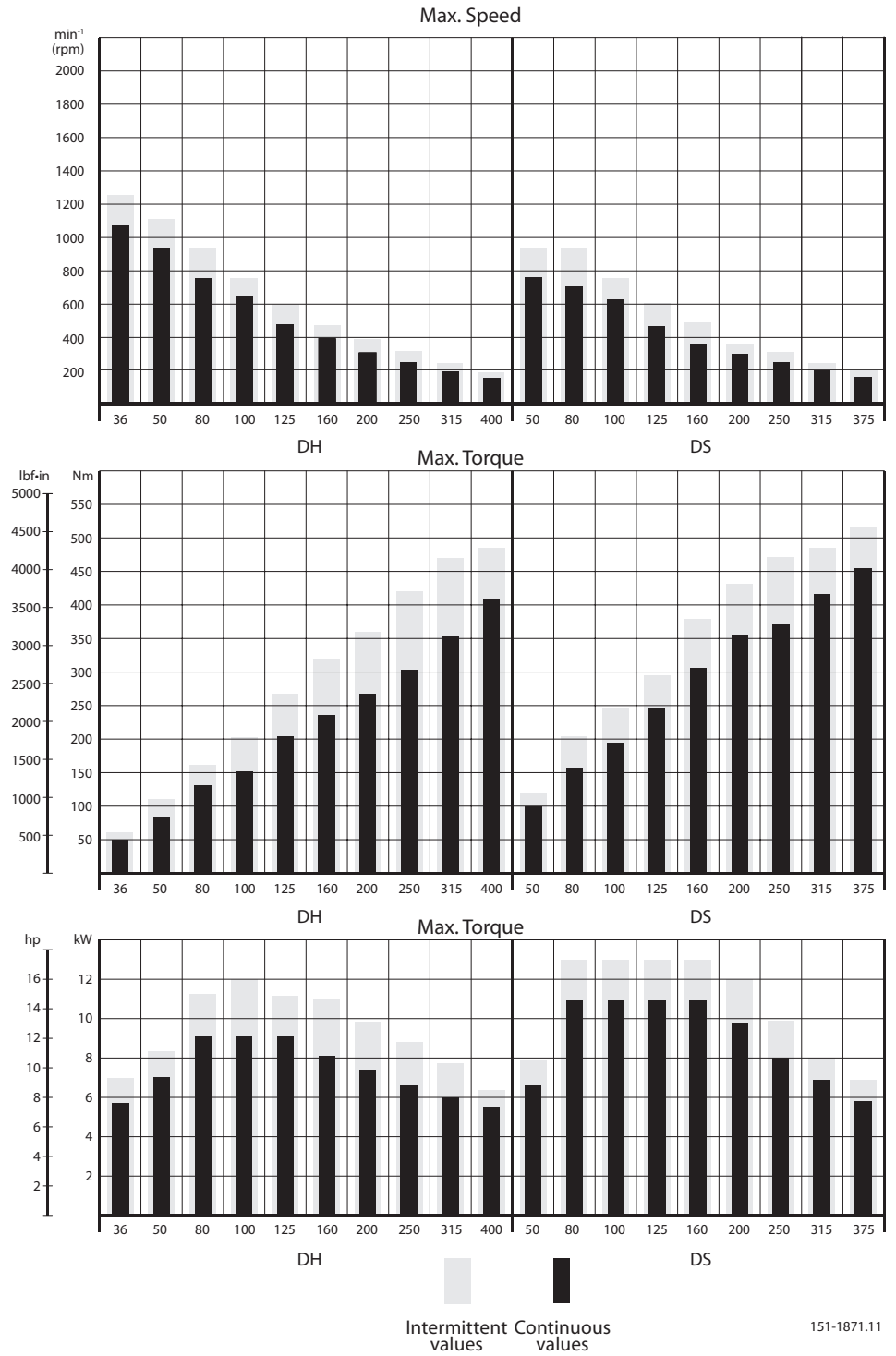

DH

Versions

Mounting flange	Shaft	Port size	European version	US version	Side port version	End port version	Flange port version	Standard shaft seal	High pressure shaft seal	Drain connection	Check valve	Specials	Main type designation
2 hole oval flange (A2-flange)	Cyl. 1 in	7/8 - 14 UNF		<input type="radio"/>	<input type="radio"/>				<input type="radio"/>	No	No		DH
		7/8 - 14 UNF		<input type="radio"/>	<input type="radio"/>				<input type="radio"/>	Yes	No		DH
		1/2 - 14 NPTF		<input type="radio"/>	<input type="radio"/>				<input type="radio"/>	No	No		DH
	1 in - 6B spl.	7/8 - 14 UNF		<input type="radio"/>	<input type="radio"/>				<input type="radio"/>	No	No		DH
Square flange (C-flange)	Cyl. 1 in	7/8 - 14 UNF		<input type="radio"/>	<input type="radio"/>				<input type="radio"/>	No	No		DH
		1/2 - 14 NPTF		<input type="radio"/>	<input type="radio"/>				<input type="radio"/>	No	No		DH

Function diagram - see page : →

*Features available (options):*

- Reverse rotation
- Drain port
- Painted

**Code Numbers**

CODE NUMBERS	DISPLACEMENT [cm <sup>3</sup> ]										Technical data - Page	Dimensions - Page
	36	50	80	100	125	160	200	250	315	400		
151-	2000	2001	2002	2003	2004	2005	2006	2007	2008	2009	8	19
151-	-	3401	3402	3403	-	-	-	3407	3408	3409	8	20
151-	2080	2081	2082	2083	-	2085	2086	2087	2088	2089	8	19
151-	2010	2011	2012	2013	-	2015	2016	2017	2018	2019	8	19
151-	2040	2041	2042	2043	2044	2045	2046	2047	2048	2049	8	21
151-	2120	2121	2122	2123	2124	2125	2126	2127	2128	2129	8	21
→	12	12	13	13	14	14	15	15	16	16		

*Ordering*

Add the four character prefix "151-" to the four digit numbers from the chart for complete code number.

Example:

151-2000 for an DH 36 with A2-flange, cyl. 1 in shaft, port size 7/8 - 14 UNF and without drain connection.

Orders will not be accepted without the four character prefix.

**Technical Data**
*Technical Data for DH with 1 in Cylindrical and 1 in-6B Splined Shaft*

Type Motor size		DH		DH		DH		DH		DH		
		36	50	80	100	125	160	200	250	315	400	
Geometric displacement	cm <sup>3</sup> [in <sup>3</sup> ]	36.0 [2.20]	48.6 [2.97]	77.8 [4.76]	97.3 [5.95]	125.0 [7.65]	155.7 [9.53]	194.6 [11.91]	242.3 [14.83]	306.1 [18.73]	389.2 [23.82]	
Max. speed	min <sup>-1</sup> [rpm]	cont.	1050	930	780	620	485	390	310	250	200	155
		int. <sup>2)</sup>	1270	1090	975	780	605	485	390	315	245	195
Max. torque <sup>1)</sup>	Nm [lbf·in]	cont.	59 [520]	79 [700]	125 [1110]	158 [1400]	203 [1800]	235 [2080]	267 [2360]	305 [2700]	355 [3140]	410 [3630]
		int. <sup>2)</sup>	76 [670]	106 [940]	163 [1440]	214 [1890]	270 [2390]	320 [2830]	360 [3190]	415 [3670]	470 [4160]	485 [4290]
Max. output	kW [hp]	cont.	5.8 [7.9]	6.8 [9.3]	8.8 [12.0]	8.8 [12.0]	8.8 [12.0]	8.1 [10.9]	7.4 [9.0]	6.6 [8.9]	6.0 [8.0]	5.5 [7.4]
		int. <sup>2)</sup>	7.0 [9.5]	8.2 [11.2]	11.4 [15.5]	11.8 [16.0]	11.0 [15.0]	11.1 [14.1]	9.8 [13.1]	8.8 [11.8]	7.8 [10.5]	6.4 [8.6]
Max. pressure drop	bar [psi]	cont.	124 [1800]	124 [1800]	124 [1800]	124 [1800]	124 [1800]	117 [1700]	103 [1500]	97 [1400]	90 [1300]	83 [1200]
		int. <sup>2)</sup>	166 [2400]	166 [2400]	166 [2400]	166 [2400]	166 [2400]	159 [2300]	141 [2050]	131 [1900]	121 [1750]	97 [1400]
Max. oil flow	l/min [US gal/ min]	cont.	38 [10.0]	45 [11.9]	60 [15.9]	60 [15.9]	60 [15.9]	60 [15.9]	60 [15.9]	60 [15.9]	60 [15.9]	60 [15.9]
		int. <sup>2)</sup>	45 [11.9]	55 [14.5]	75 [19.8]	75 [19.8]	75 [19.8]	75 [19.8]	75 [19.8]	75 [19.8]	7 [19.8]	75 [19.8]
Max. starting pressure with unloaded shaft	bar [psi]	10 [145]	10 [145]	10 [145]	10 [145]	10 [145]	10 [145]	7 [100]	7 [100]	7 [100]	7 [100]	
Min. starting torque	at max. press. drop cont. Nm [lbf·in]	53 [470]	72 [635]	115 [1020]	144 [1275]	185 [1640]	217 [1920]	240 [2125]	279 [2470]	330 [2920]	385 [3405]	
	at max. press. drop int. <sup>2)</sup> Nm [lbf·in]	66 [585]	96 [850]	154 [1360]	192 [1700]	247 [2185]	295 [2610]	327 [2895]	379 [3355]	444 [3930]	451 [3990]	

Type		Max. inlet pressure	Max return pressure with drain line
DH 36 - 400	bar [psi]	138 [2000]	138 [2000]
	cont.		
DH 36 - 400	bar [psi]	172 [2500]	172 [2500]
	int. <sup>1)</sup>		

<sup>1)</sup> 6B splined shaft is recommended for operating torque of 280 Nm [2500 lbf·in] or more.

<sup>2)</sup> Intermittent operation: the permissible values may occur for max. 10% of every minute.

Technical Data

Max. Permissible Shaft Seal Pressure

*DH with HPS and without drain connection:*  
The shaft seal pressure equals the average of input pressure and return pressure.

$$P_{\text{seal}} = \frac{P_{\text{in}} + P_{\text{return}}}{2}$$

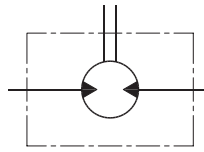

151-1743.10

*DH with HPS and drain connection:*  
The shaft seal pressure equals the pressure in the drain line.

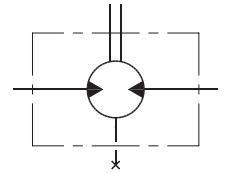

151-1855.10

Max. permissible shaft seal pressure

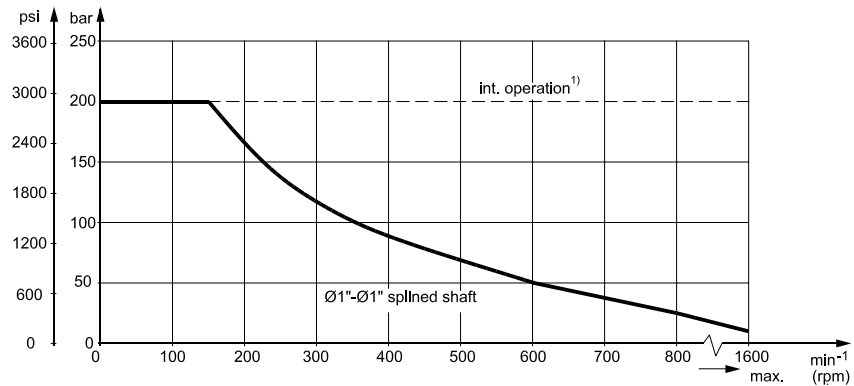

151-1872.10

Pressure Drop in Motor

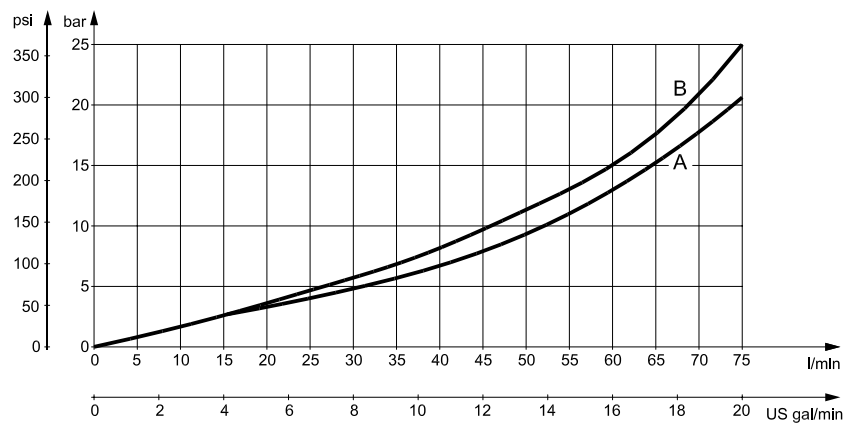

151-1873.10

The curve applies to an unloaded motor shaft and an oil viscosity of 35 mm<sup>2</sup>/s [165 SUS]

- A: DH 80 - 400
- B: DH 36-50

Technical Data

Oil Flow in Drain Line

The table shows the max. oil flow in the drain line at a return pressure less than 5-10 bar [75-150 psi].

Pressure drop bar [psi]	Viscosity mm <sup>2</sup> /s [SUS]	Oil flow in drain line l/min [US gal/min]
100 [1450]	20 [100]	2.5 [0.66]
	35 [165]	1.8 [0.78]
140 [2030]	20 [165]	3.5 [0.93]
	35 [165]	2.8 [0.74]

Direction of Shaft Rotation

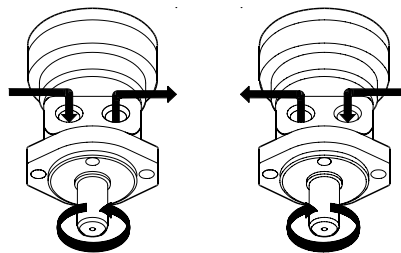

151-1874.10

Technical Data

Permissible Shaft Loads for DH

- The permissible radial shaft load ( $P_R$ ) depends on
- speed (n)
  - distance (l) from the point of load to the mounting flange
  - mounting flange version
  - shaft version

Mounting flange	Square flange 2-hole oval flange (US version)
Shaft version	1 in cylindrical shaft 1 in-6B splined shaft
Permissible shaft load ( $P_R$ ) l in mm	$\frac{650}{n} \times \frac{228000}{87 + l} \text{ N}^*$
Permissible shaft load ( $P_R$ ) l in inch	$\frac{1460}{n} \times \frac{898}{3.425 + l} \text{ lbf}^*$

\*  $n \geq 200 \text{ min}^{-1} \text{ (rpm)}$ ;  $l \leq 55 \text{ mm [2.2 in]}$   
 $n < 200 \text{ min}^{-1} \text{ (rpm)}$ ;  $\Rightarrow P_{Rmax} = 6500 \text{ N [1460 lbf]}$ , when using above formulas n has to be  $200 \text{ min}^{-1} \text{ (rpm)}$ .

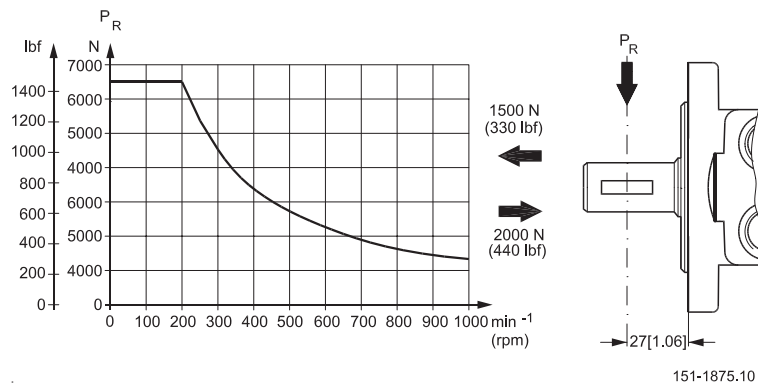

The curve shows the relation between  $P_R$  and n

- when  $l = 27 \text{ mm [1.06 in]}$  for motors with oval and square mounting flange

Technical Data

Function Diagrams

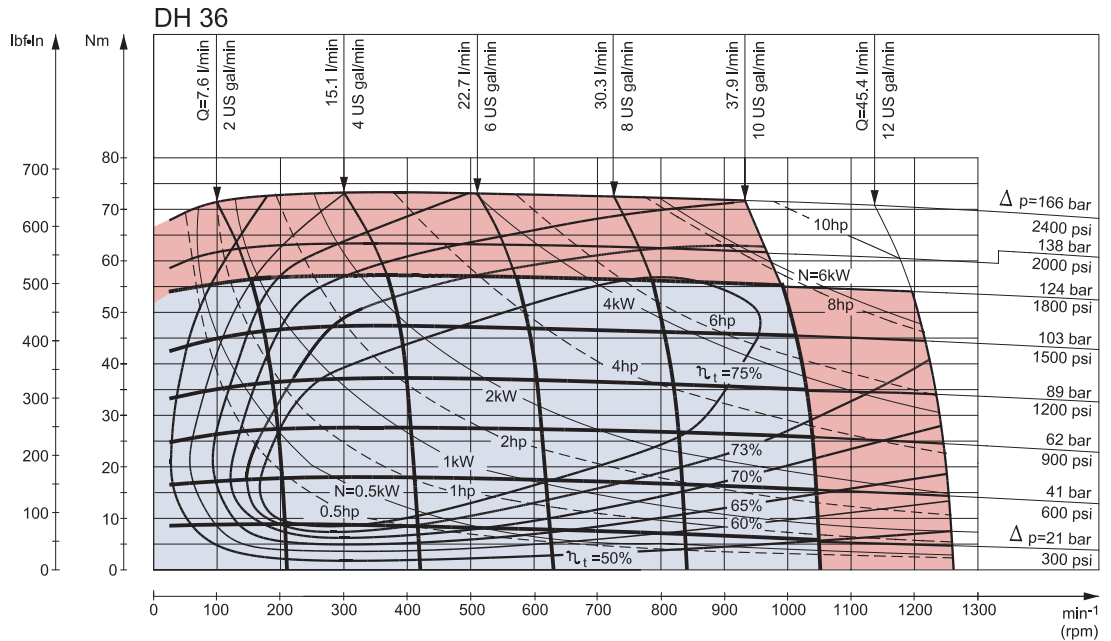

151-1910.10

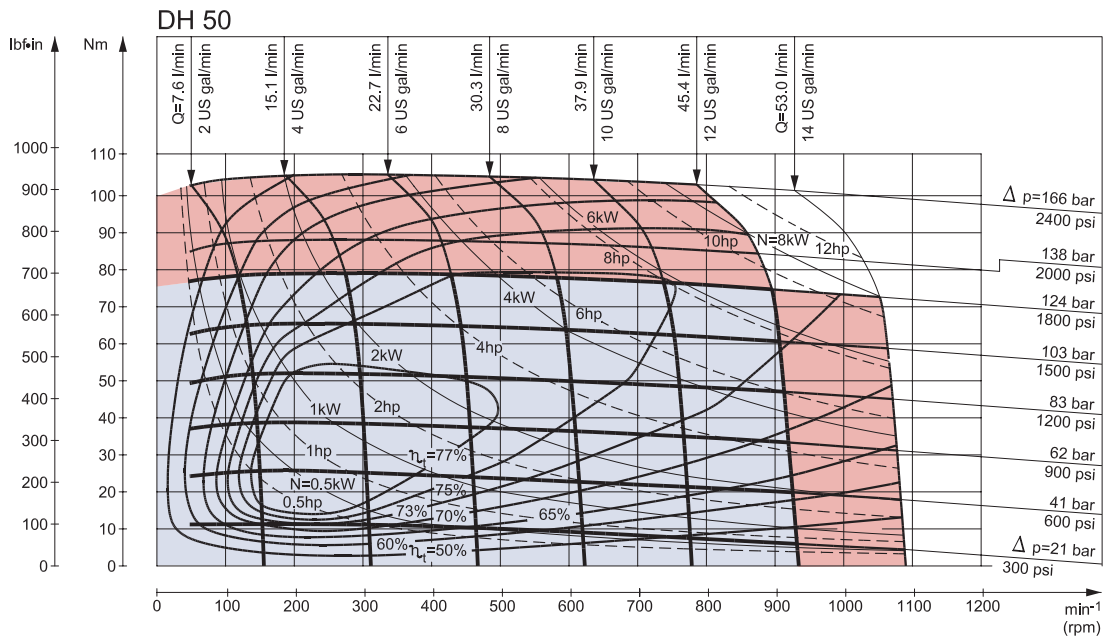

151-1910.10

Explanation of function diagram use, basis and conditions can be found on page 4.

- A: Continuous range
- B: Intermittent range (max. 10% operation every minute)

Max. permissible continuous/intermittent pressure drop for the actual shaft version can be found on page 8.

Intermittent pressure drop and oil flow must not occur simultaneously.

Technical Data

Function Diagrams

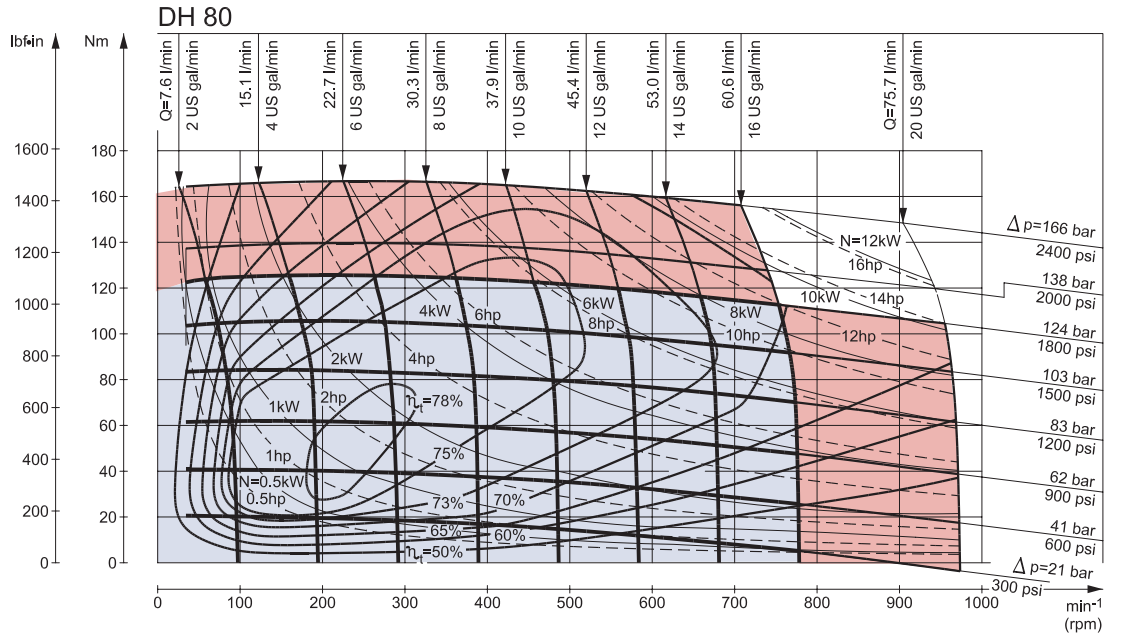

151-1902.10

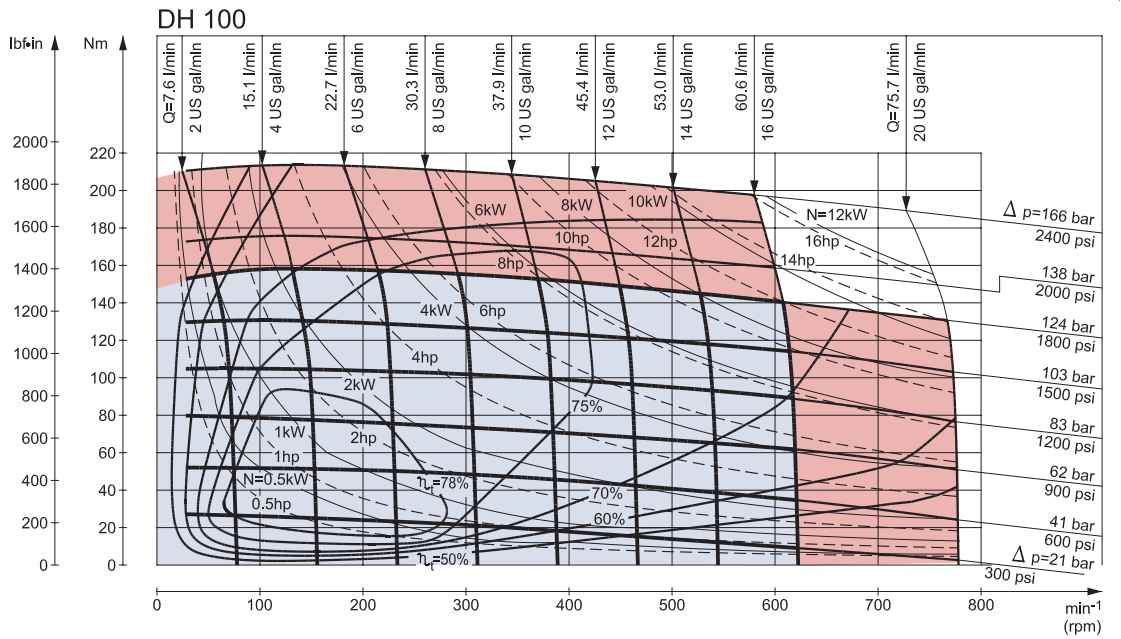

151-1903.10

Explanation of function diagram use, basis and conditions can be found on page 4.

- A: Continuous range
- B: Intermittent range (max. 10% operation every minute)

Max. permissible continuous/intermittent pressure drop for the actual shaft version can be found on page 8.

Intermittent pressure drop and oil flow must not occur simultaneously.

Technical Data

Function Diagrams

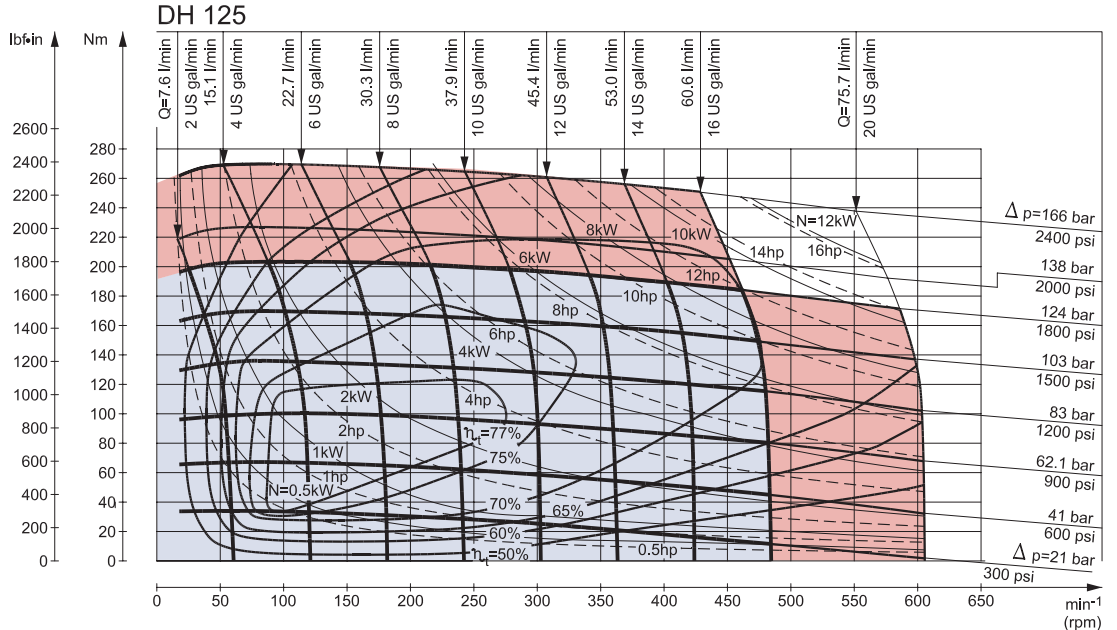

151-1904.10

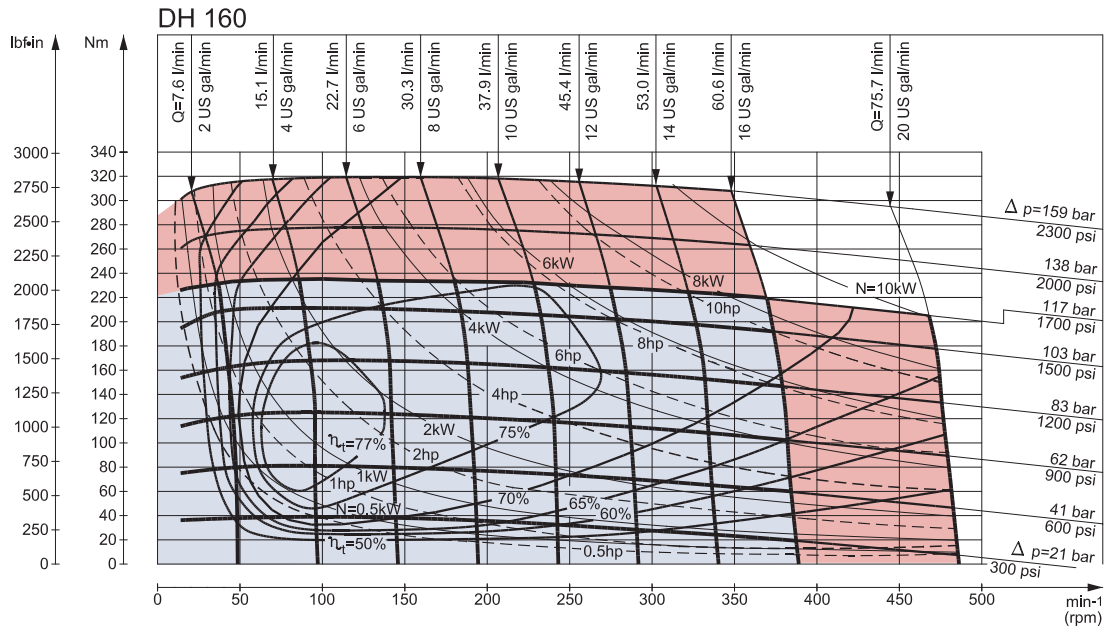

151-1885.10

Explanation of function diagram use, basis and conditions can be found on page 4.

- A: Continuous range
- B: Intermittent range (max. 10% operation every minute)

Max. permissible continuous/intermittent pressure drop for the actual shaft version can be found on page 8.

Intermittent pressure drop and oil flow must not occur simultaneously.

Technical Data

Function Diagrams

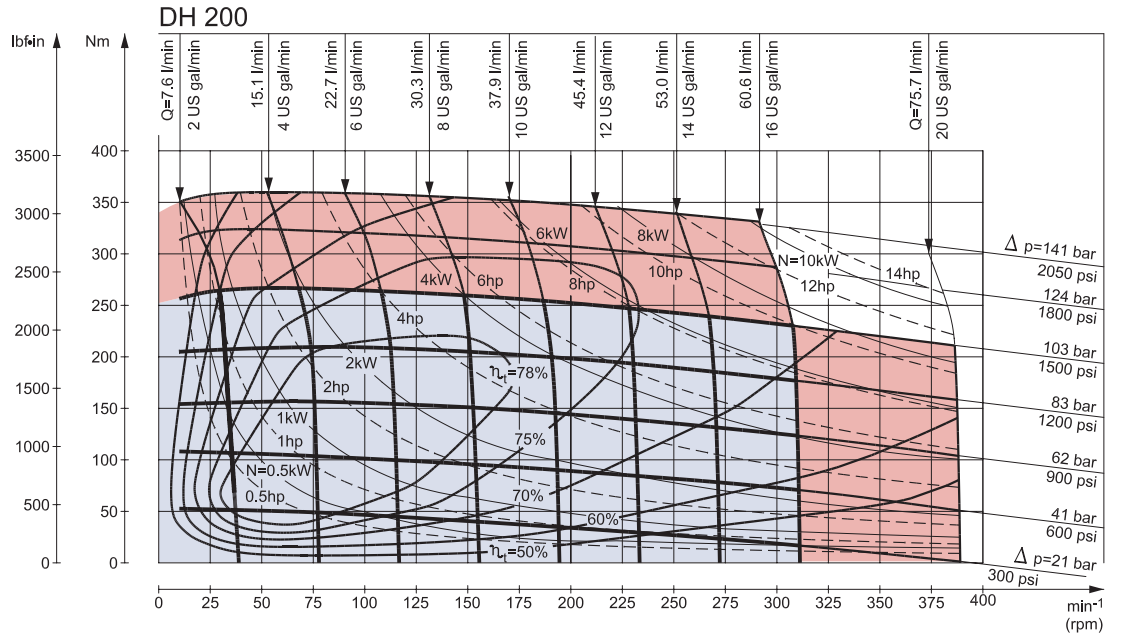

151-1905.10

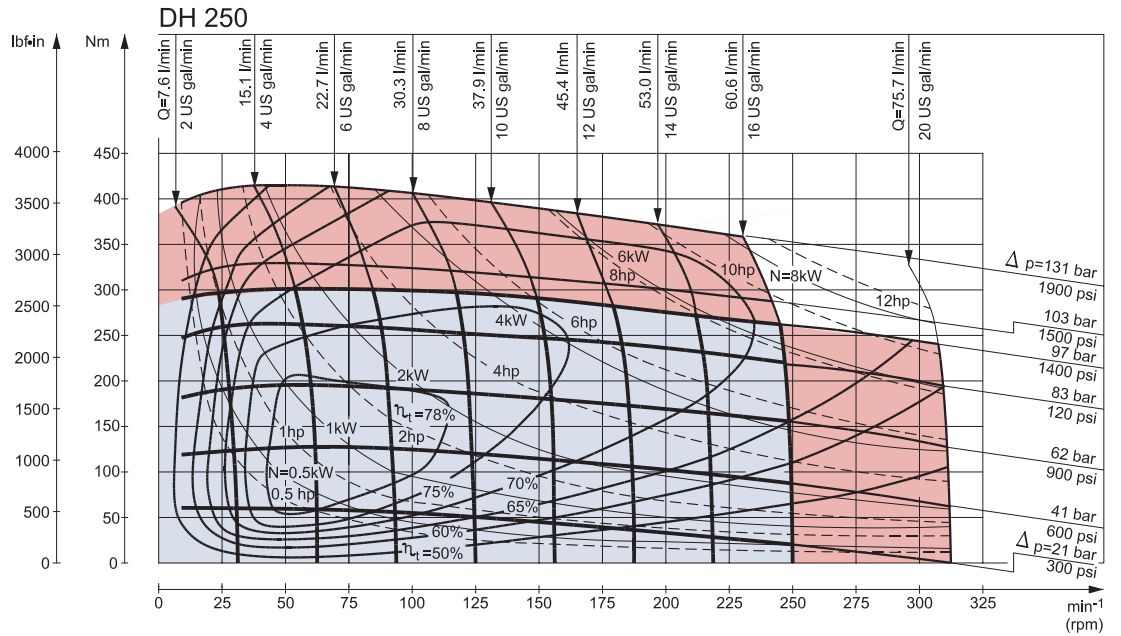

151-1906.10

Explanation of function diagram use, basis and conditions can be found on page 4.

- A: Continuous range
- B: Intermittent range (max. 10% operation every minute)

Max. permissible continuous/intermittent pressure drop for the actual shaft version can be found on page 8.

Intermittent pressure drop and oil flow must not occur simultaneously.

Technical Data

Function Diagrams

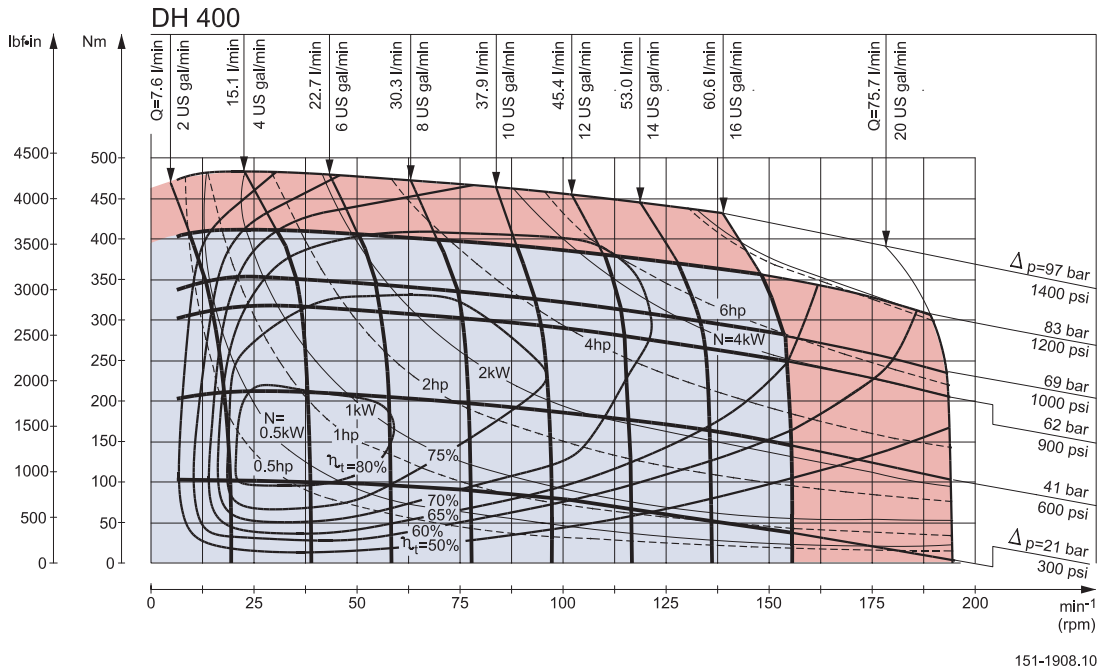
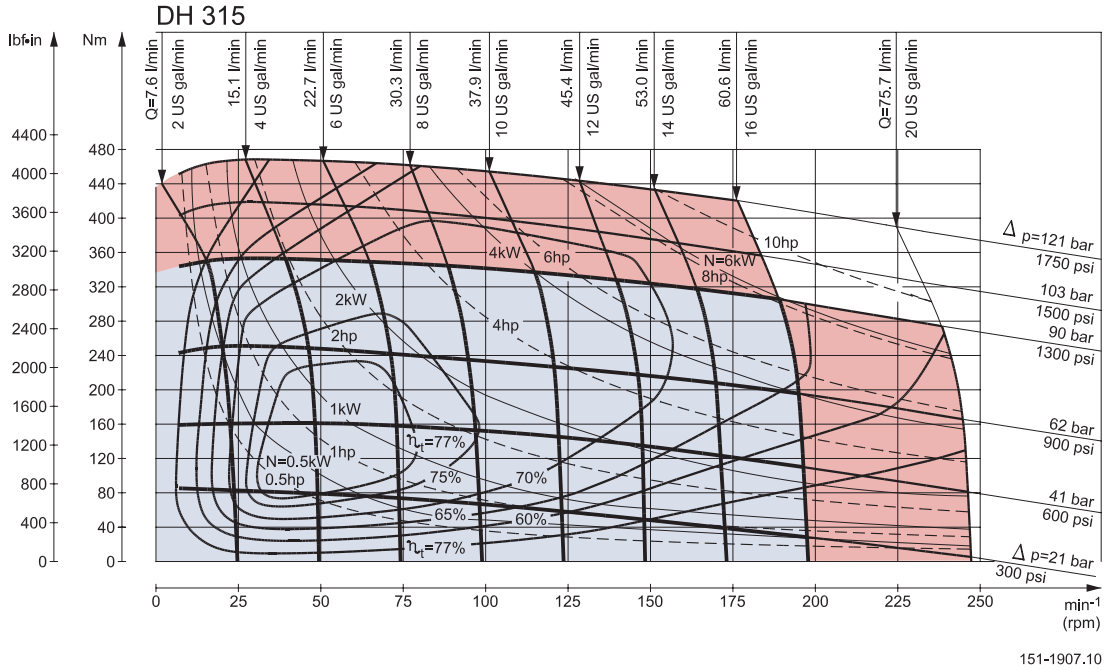

Explanation of function diagram use, basis and conditions can be found on page 4.

- A: Continuous range
- B: Intermittent range (max. 10% operation every minute)

Max. permissible continuous/intermittent pressure drop for the actual shaft version can be found on page 8.

Intermittent pressure drop and oil flow must not occur simultaneously.

Technical Data

Shaft Version

**US version**

- A: Cylindrical shaft  
1 in
- C: Woodruff key  
1/4 x 1 in  
SAE J502

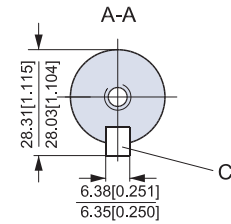
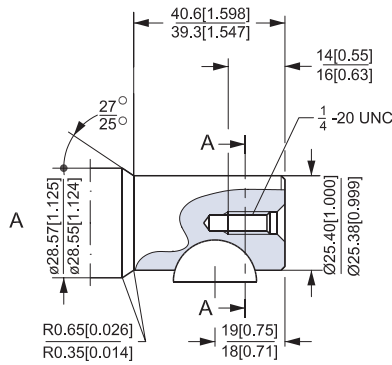

**US version**

- B: Splined shaft  
1 in - SAE 6B
- \* Deviates from B.S. 2059  
(SAE 6B)

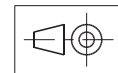
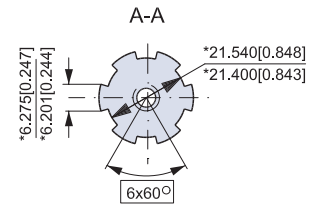
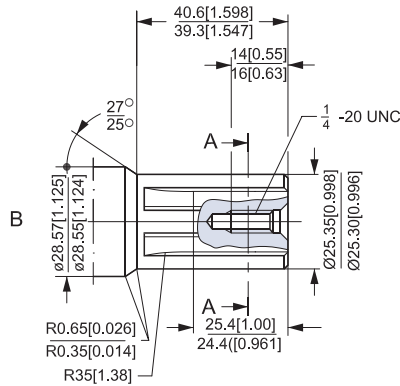

151-1876.10

6B splined shaft is recommended for operating torque of 280 Nm [2500 lbf-in] or more.

Port Thread Versions

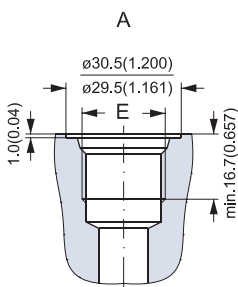

A: UNF main ports  
E:  $\frac{7}{8}$  - 14 UNF  
O-ring boss port

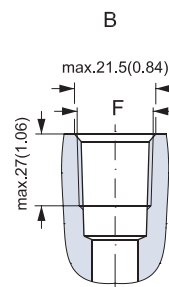

B: NPTF main ports  
F:  $\frac{1}{2}$  - 14 NPTF

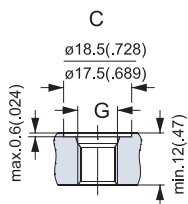

C: UNF drain port  
G:  $\frac{7}{16}$  - 20 UNF  
O-ring boss port

Dimensions

Dimensions – US Version

Side port version with 2 hole oval mounting flange (A2-flange).  
Port thread version.

Type	L mm [in]	L mm [in]
DH 36	119.7 [4.71]	5.9 [0.23]
DH 50	120.3 [4.74]	6.5 [0.26]
DH 80	124.2 [4.89]	10.4 [0.41]
DH 100	126.8 [4.99]	13.0 [0.51]
DH 125	130.5 [5.14]	16.7 [0.66]
DH 160	134.6 [5.30]	20.8 [0.82]
DH 200	139.8 [5.50]	26.0 [1.02]
DH 250	146.3 [5.76]	32.5 [1.28]
DH 315	154.7 [6.09]	40.9 [1.61]
DH 400	165.8 [6.53]	52.0 [2.05]

D: 7/8 - 14 UNF,  
16.7 mm [0.66 in] deep  
O-ring boss port or  
1/2 - 14 NPTF

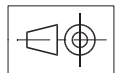
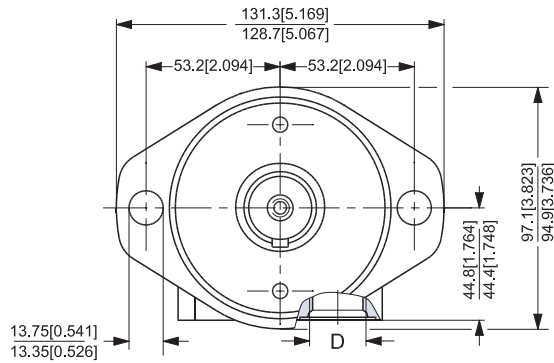
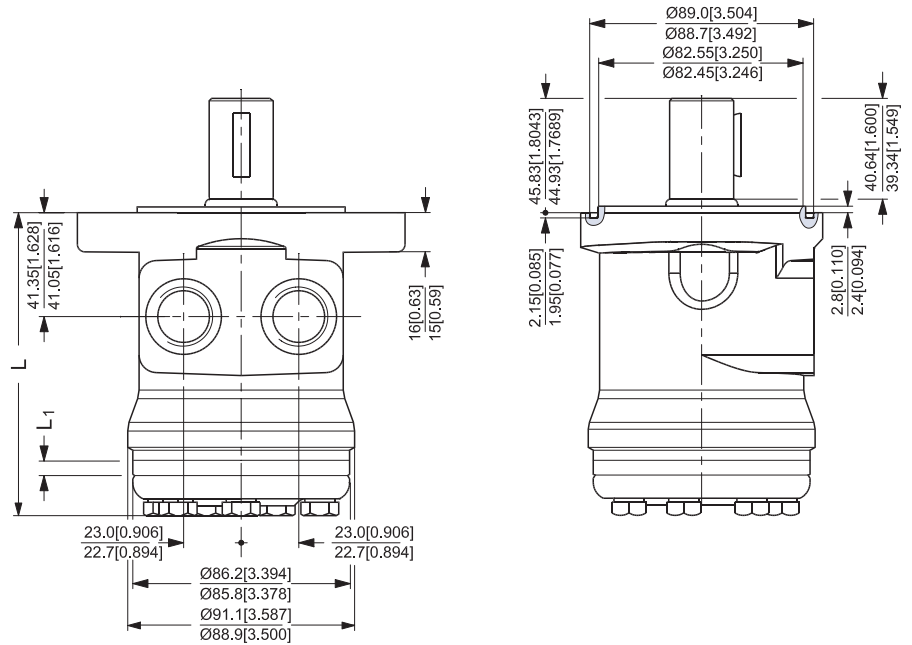

151-1877.10

Dimensions

Dimensions – US Version

Side port version with 2 hole oval mounting flange (A2-flange).  
With drain connection.  
Port thread version.

Type	L mm [in]	L mm [in]
DH 36	119.7 [4.71]	5.9 [0.23]
DH 50	120.3 [4.74]	6.5 [0.26]
DH 80	124.2 [4.89]	10.4 [0.41]
DH 100	126.8 [4.99]	13.0 [0.51]
DH 125	130.5 [5.14]	16.7 [0.66]
DH 160	134.6 [5.30]	20.8 [0.82]
DH 200	139.8 [5.50]	26.0 [1.02]
DH 250	146.3 [5.76]	32.5 [1.28]
DH 315	154.7 [6.09]	40.9 [1.61]
DH 400	165.8 [6.53]	52.0 [2.05]

C: 7/16 - 20 UNF,  
12 mm [0.47 in] deep  
D: 7/8 - 14 UNF,  
16.7 mm [0.66 in] deep  
O-ring boss port or  
1/2 - 14 NPTF

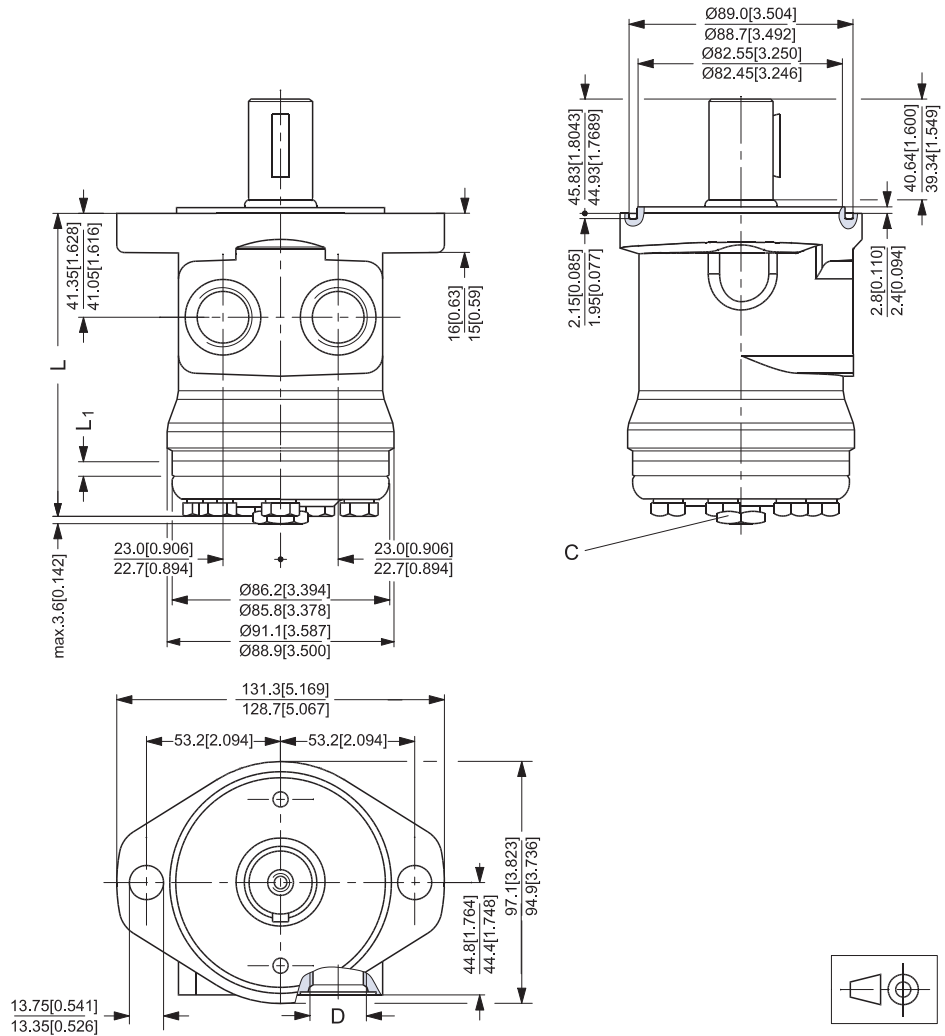

151-1890.10

Dimensions

Dimensions – US Version

Side port version with square mounting flange (C-flange).  
Port thread version.

Type	L mm [in]	L mm [in]
DH 36	119.7 [4.71]	5.9 [0.23]
DH 50	120.3 [4.74]	6.5 [0.26]
DH 80	124.2 [4.89]	10.4 [0.41]
DH 100	126.8 [4.99]	13.0 [0.51]
DH 125	130.5 [5.14]	16.7 [0.66]
DH 160	134.6 [5.30]	20.8 [0.82]
DH 200	139.8 [5.50]	26.0 [1.02]
DH 250	146.3 [5.76]	32.5 [1.28]
DH 315	154.7 [6.09]	40.9 [1.61]
DH 400	165.8 [6.53]	52.0 [2.05]

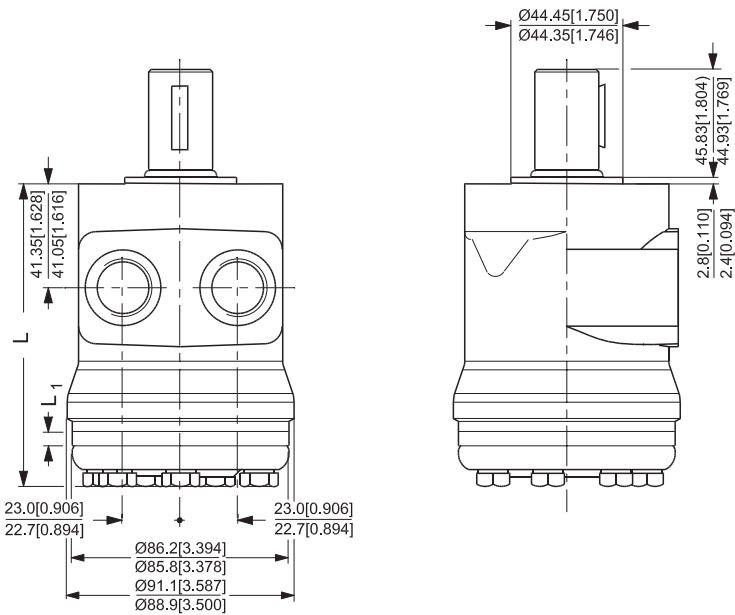

D: 7/8 - 14 UNF;  
16.7 mm [0.66 in] deep  
or 1/2 - 14 NPTF  
E: 3/8 - 16 UNC;  
15 mm [0.59 in] deep  
(4-off)

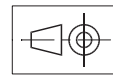
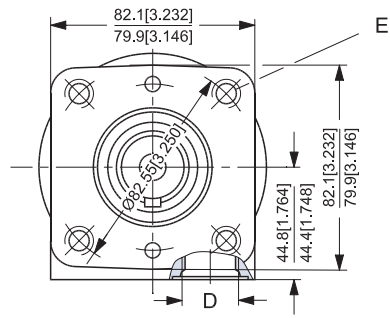

151-1879.10

DS

Versions

Mounting flange	Shaft	Port size	European version	US version	Side port version	End port version	Flange port version	Standard shaft seal	High pressure shaft seal	Drain connection	Check valve	Specials	Main type designation
2 hole oval flange (A2-flange)	Cyl. 1 in	7/8 - 14 UNF		<input type="radio"/>	<input type="radio"/>				<input type="radio"/>	No	No		DS
		7/8 - 14 UNF		<input type="radio"/>	<input type="radio"/>				<input type="radio"/>	Yes	No		DS
		1/2 - 14 NPTF		<input type="radio"/>	<input type="radio"/>				<input type="radio"/>	No	No		DS
	1 in - 6B spl.	7/8 - 14 UNF		<input type="radio"/>	<input type="radio"/>				<input type="radio"/>	No	No		DS
Square flange (C-flange)	Cyl. 1 in	7/8 - 14 UNF		<input type="radio"/>	<input type="radio"/>				<input type="radio"/>	No	No		DS
		1/2 - 14 NPTF		<input type="radio"/>	<input type="radio"/>				<input type="radio"/>	No	No		DS
Function diagram - see page : →													

Features available (options) :

- Reverse rotation
- Drain port
- Painted

Code Numbers

CODE NUMBERS	DISPLACEMENT [cm <sup>3</sup> ]									Technical data - Page	Dimensions - Page
	50	80	100	125	160	200	250	315	375		
151-	2301	2302	2303	2304	2305	2306	2307	2308	-	24	35
151-	-	3702	3703	3704	-	3706	3707	3708	-	24	36
151-	-	2382	2383	-	2385	2386	2387	-	2389	24	35
151-	-	2312	2313	2314	-	2316	-	2318	2319	24	35
151-	2341	2342	2343	2344	2345	2346	2347	2348	2349	24	37
151-	2421	-	2423	-	2425	2426	2427	-	2429	24	37
→	28	28	29	29	30	30	31	31	32		

*Ordering*

Add the four character prefix "151-" to the four digit numbers from the chart for complete code number.

Example:

151-2305 for an DS 160 with A2-flange, cyl. 1 in shaft, port size 7/8 - 14 UNF and without drain connection.

---

Orders will not be accepted without the four character prefix.

---

**Technical Data**
*Technical data for DS with 1 in cylindrical and 1 in-6b splined shaft*

Type Motor size			DS	DS	DS	DS	DS	DS	DS	DS	
			50	80	100	125	160	200	250	315	375
Geometric displacement	cm <sup>3</sup> [in <sup>3</sup> ]		51.6 [3.16]	80.3 [4.91]	99.8 [6.11]	124.1 [7.60]	155.4 [9.51]	198.2 [12.13]	248.1 [15.18]	310.1 [18.98]	390.7 [23.91]
Max. speed	min <sup>-1</sup> [rpm]	cont.	770	755	605	480	380	305	245	190	155
		int. <sup>2)</sup>	955	945	760	600	475	380	305	240	195
Max. torque <sup>1)</sup>	Nm [lbf·in]	cont.	93 [820]	159 [1405]	193 [1710]	247 [2190]	314 [2780]	350 [3100]	370 [3270]	415 [3670]	455 [4030]
		int. <sup>2)</sup>	116 [1025]	206 [1820]	237 [2100]	304 [2690]	378 [3350]	429 [3800]	469 [4150]	485 [4290]	515 [4560]
Max. output	kW [hp]	cont.	6.6 [8.9]	10.7 [14.3]	10.7 [14.3]	10.7 [14.3]	10.7 [14.3]	9.6 [12.9]	8.0 [10.7]	6.9 [9.3]	5.8 [7.8]
		int. <sup>2)</sup>	7.8 [10.5]	13.0 [17.4]	13.0 [17.4]	13.0 [17.4]	12.6 [16.9]	11.8 [15.8]	9.9 [13.3]	8.0 [10.7]	6.9 [9.3]
Max. pressure drop	bar [psi]	cont.	138 [2000]	138 [2000]	138 [2000]	138 [2000]	138 [2000]	124 [1800]	107 [1550]	97 [1400]	83 [1200]
		int. <sup>2)</sup>	172 [2500]	172 [2500]	172 [2500]	172 [2500]	172 [2500]	155 [2250]	138 [2000]	114 [1650]	97 [1400]
Max. oil flow	l/min [US gal/ min]	cont.	40 [10.6]	60 [15.9]	60 [15.9]	60 [15.9]	60 [15.9]	60 [15.9]	60 [15.9]	60 [15.9]	60 [15.9]
		int. <sup>2)</sup>	50 [13.2]	75 [19.8]	75 [19.8]	75 [19.8]	75 [19.8]	75 [19.8]	75 [19.8]	75 [19.8]	75 [19.8]
Max. starting pressure with unloaded shaft	bar [psi]		10 [145]	10 [145]	10 [145]	10 [145]	10 [145]	10 [145]	7 [100]	7 [100]	7 [100]
Min. starting torque	at max. press. drop cont. Nm [lbf·in]		76 [670]	118 [1045]	164 [1455]	204 [1810]	256 [2265]	294 [2600]	318 [2815]	358 [3170]	387 [3425]
	at max. press. drop int. <sup>2)</sup> Nm [lbf·in]		95 [840]	148 [1305]	205 [1820]	255 [2260]	320 [2830]	367 [3250]	408 [3615]	423 [3745]	453 [4010]

Type		Max. inlet pressure	Max return pressure with drain line
DS 50 - 375	bar [psi]	138 [2000]	138 [2000]
	cont.		
DS 50 - 375	bar [psi]	172 [2500]	172 [2500]
	int. <sup>1)</sup>		

1) 6B splined shaft is recommended for operating torque of 280 Nm [2500 lbf·in] or more.

2) Intermittent operation: the permissible values may occur for max. 10% of every minute.

Technical Data

Max. Permissible Shaft Seal Pressure

DS with HPS and without drain connection:  
The shaft seal pressure equals the average of input pressure and return pressure.

$$P_{\text{seal}} = \frac{P_{\text{in}} + P_{\text{return}}}{2}$$

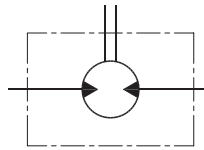

151-1743.10

DS with HPS and drain connection:  
The shaft seal pressure equals the pressure in the drain line.

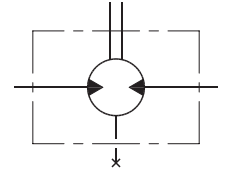

151-1855.10

Max. permissible shaft seal pressure

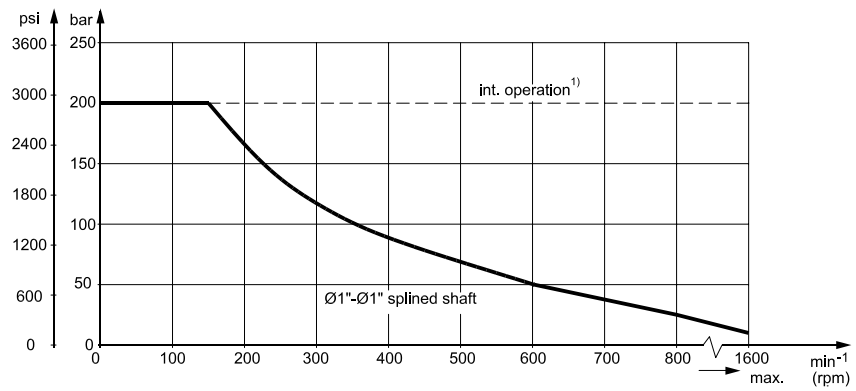

151-1872.10

Pressure Drop in Motor

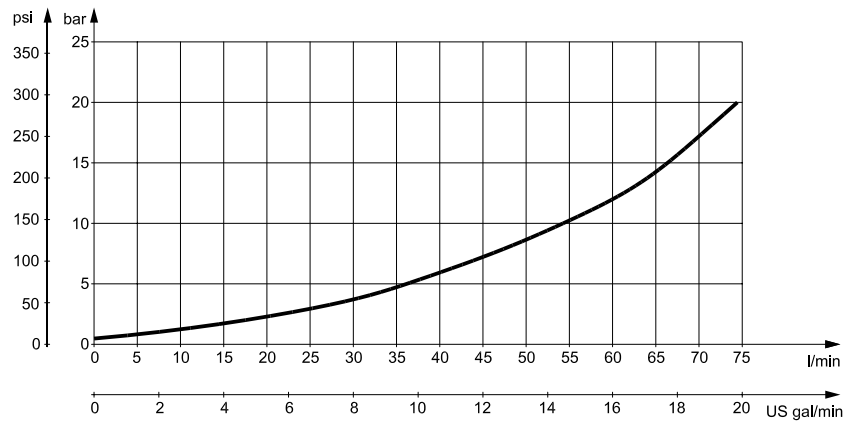

151-1913.10

The curve applies to an unloaded motor shaft and an oil viscosity of 35 mm<sup>2</sup>/s [165 SUS]

Technical Data

Oil Flow in Drain Line

The table shows the max. oil flow in the drain line at a return pressure less than 5-10 bar [75-150 psi].

Pressure drop bar [psi]	Viscosity mm <sup>2</sup> /s [SUS]	Oil flow in drain line l/min [US gal/min]
100 [1450]	20 [100]	2.5 [0.66]
	35 [165]	1.8 [0.78]
140 [2030]	20 [165]	3.5 [0.93]
	35 [165]	2.8 [0.74]

Direction of Shaft Rotation

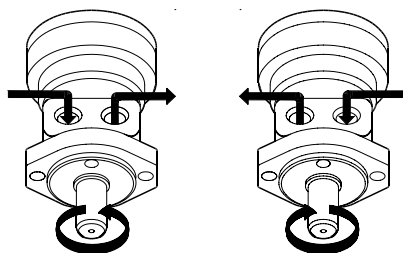

151-1874.10

Technical Data

Permissible Shaft Loads for DS

The permissible radial shaft load ( $P_R$ ) depends on

- speed (n)
- distance (l) from the point of load to the mounting flange
- mounting flange version
- shaft version

Mounting flange	Square flange 2-hole oval flange (US version)
Shaft version	1 in cylindrical shaft 1 in-6B splined shaft
Permissible shaft load ( $P_R$ ) l in mm	$\frac{650}{n} \times \frac{228000}{87 + l} \text{ N}^*$
Permissible shaft load ( $P_R$ ) l in inch	$\frac{1460}{n} \times \frac{898}{3.425 + l} \text{ lbf}^*$

\*  $n \geq 200 \text{ min}^{-1} \text{ (rpm)}$ ;  $l \leq 55 \text{ mm [2.2 in]}$   
 $n < 200 \text{ min}^{-1} \text{ (rpm)}$ ;  $\Rightarrow P_{Rmax} = 6500 \text{ N [1460 lbf]}$ , when using above formulas n has to be  $200 \text{ min}^{-1} \text{ (rpm)}$ .

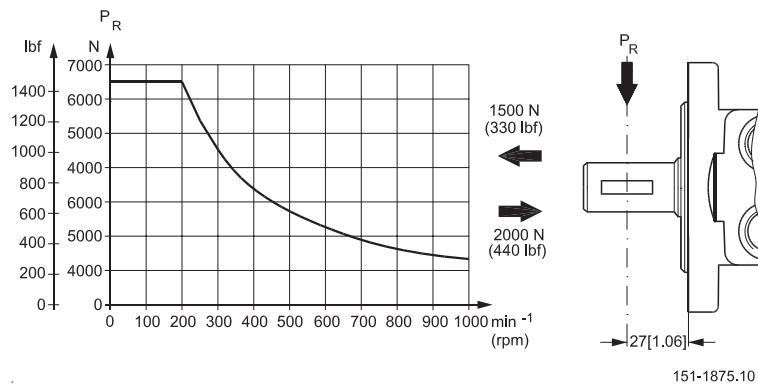

The curve shows the relation between  $P_R$  and n

- when  $l = 27 \text{ mm [1.06 in]}$  for motors with oval and square mounting flange

Technical Data

Function Diagrams

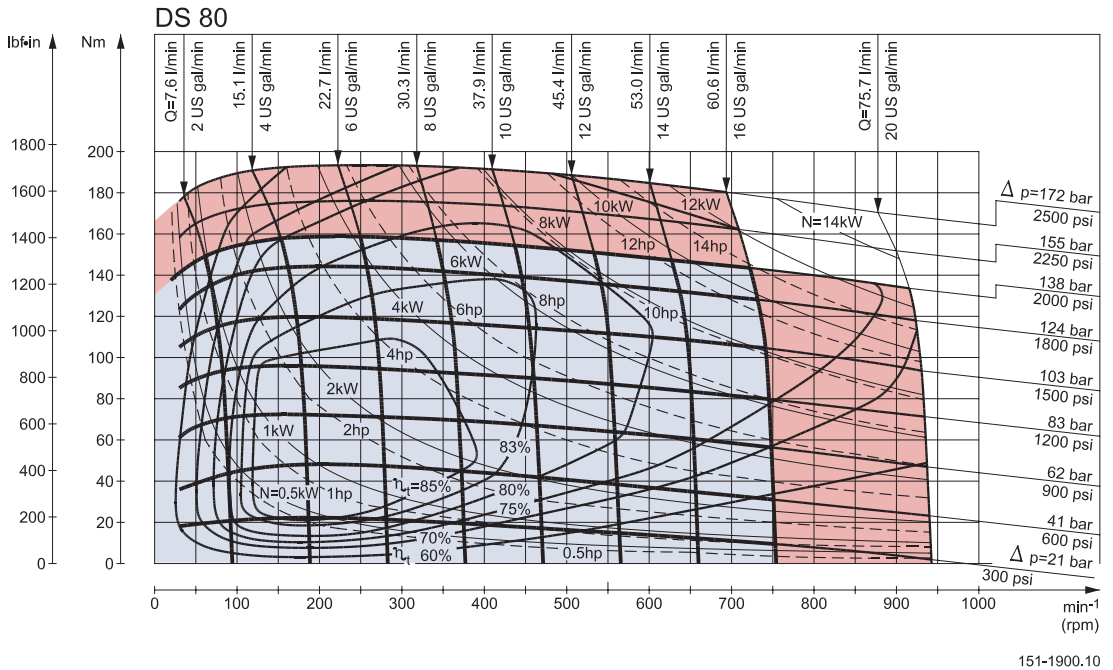
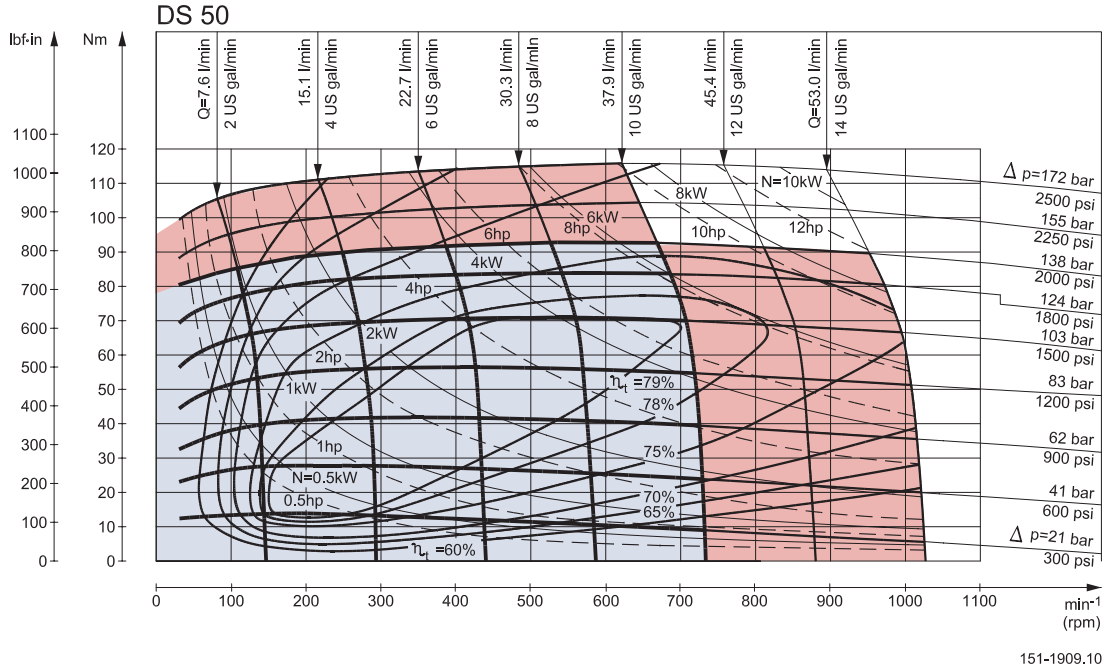

Explanation of function diagram use, basis and conditions can be found on page 4.

- A: Continuous range
- B: Intermittent range (max. 10% operation every minute)

Max. permissible continuous/intermittent pressure drop for the actual shaft version can be found on page 24.

Intermittent pressure drop and oil flow must not occur simultaneously.

Technical Data

Function Diagrams

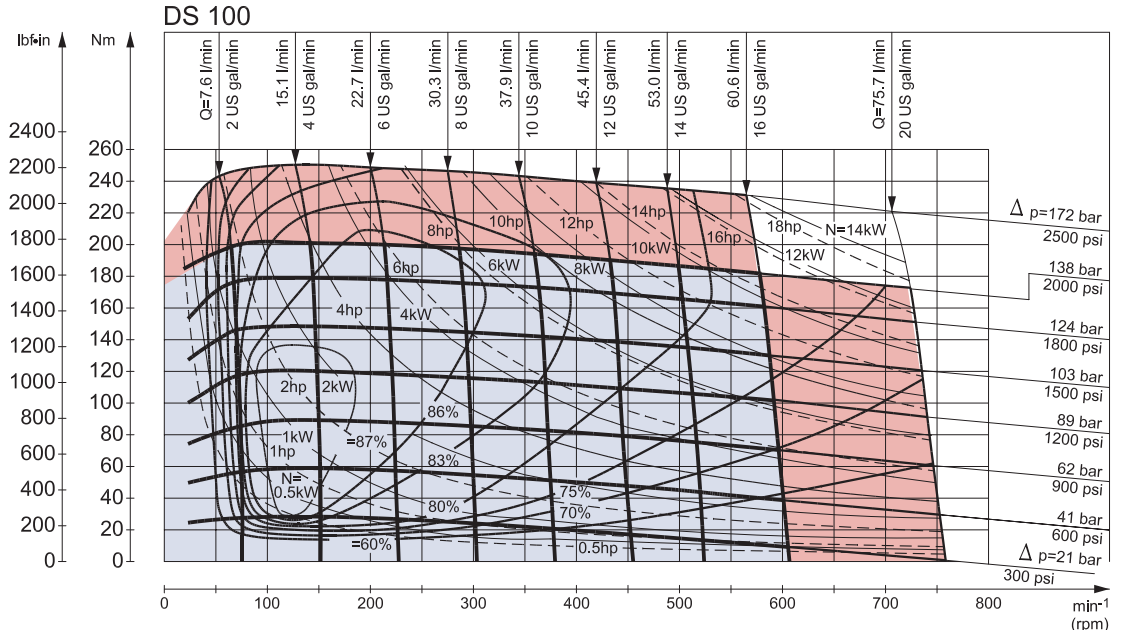

151-1889.10

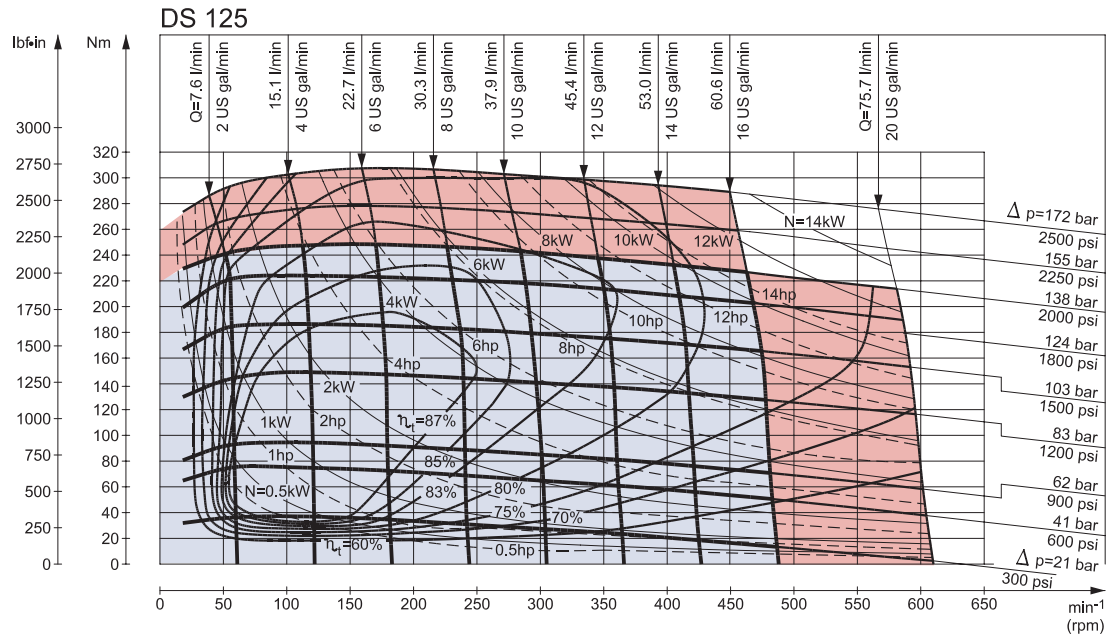

151-1886.10

Explanation of function diagram use, basis and conditions can be found on page 4.

- A: Continuous range
- B: Intermittent range (max. 10% operation every minute)

Max. permissible continuous/intermittent pressure drop for the actual shaft version can be found on page 24.

Intermittent pressure drop and oil flow must not occur simultaneously.

Technical Data

Function Diagrams

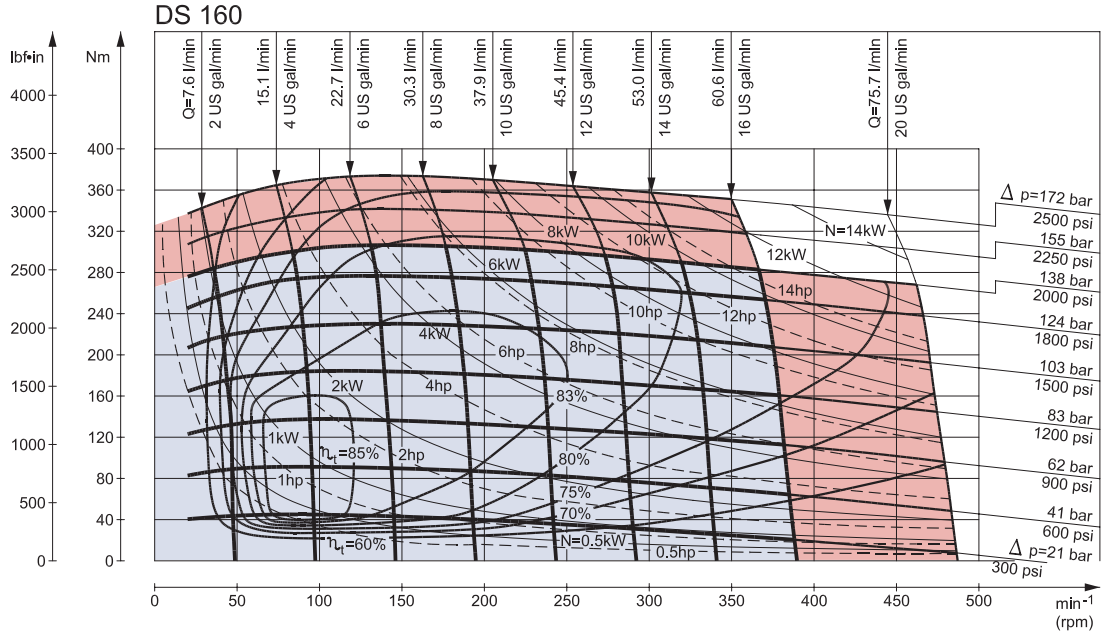

151-1883.10

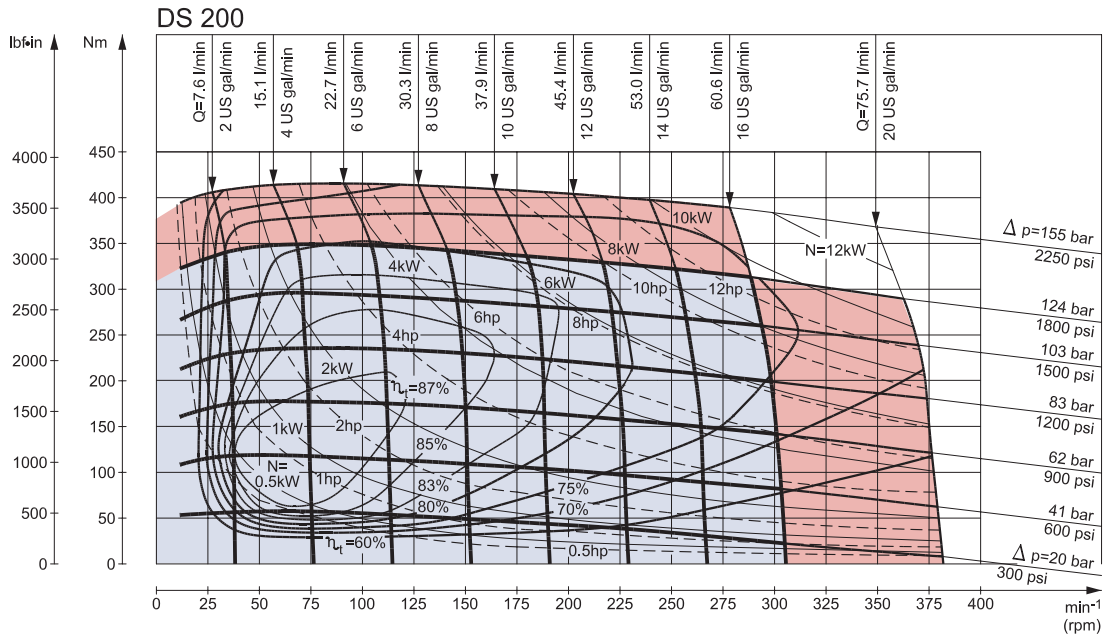

151-1887.10

Explanation of function diagram use, basis and conditions can be found on page 4.

- A: Continuous range
- B: Intermittent range (max. 10% operation every minute)

Max. permissible continuous/intermittent pressure drop for the actual shaft version can be found on page 24.

Intermittent pressure drop and oil flow must not occur simultaneously.

Technical Data

Function Diagrams

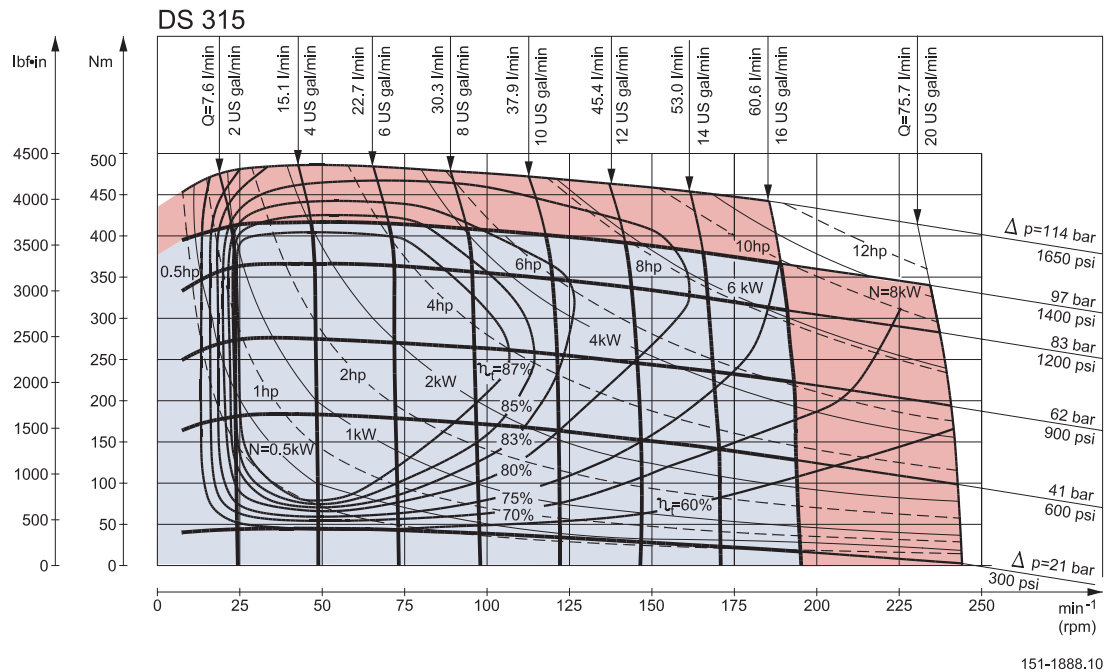
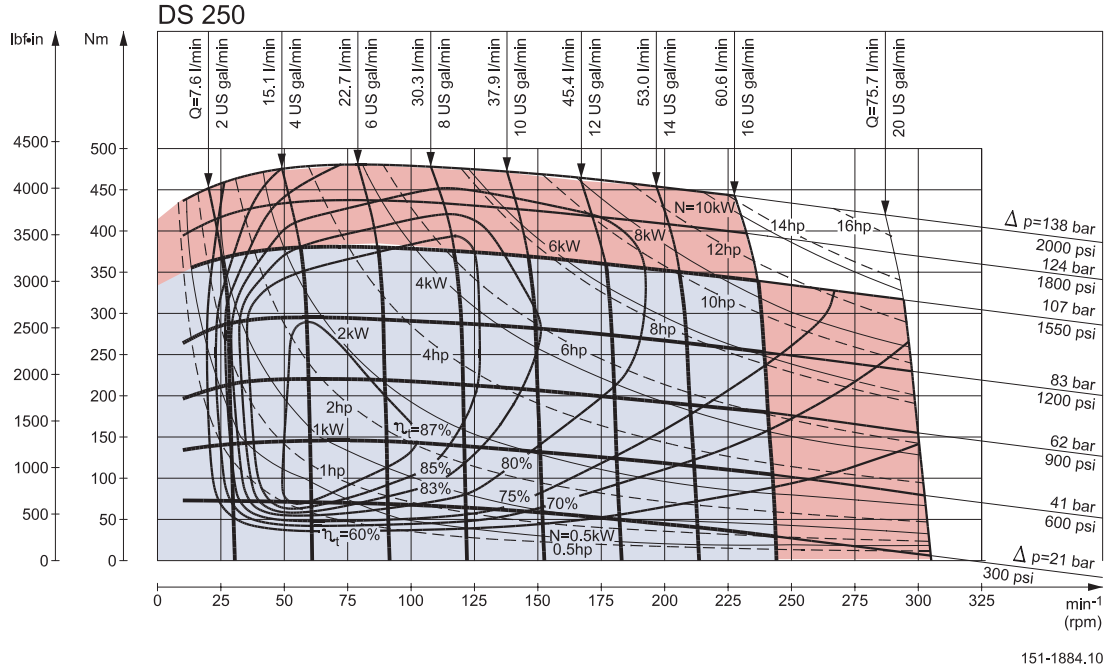

Explanation of function diagram use, basis and conditions can be found on page 4.

- A: Continuous range
- B: Intermittent range (max. 10% operation every minute)

Max. permissible continuous/intermittent pressure drop for the actual shaft version can be found on page 24.

Intermittent pressure drop and oil flow must not occur simultaneously.

Technical Data

Function Diagrams

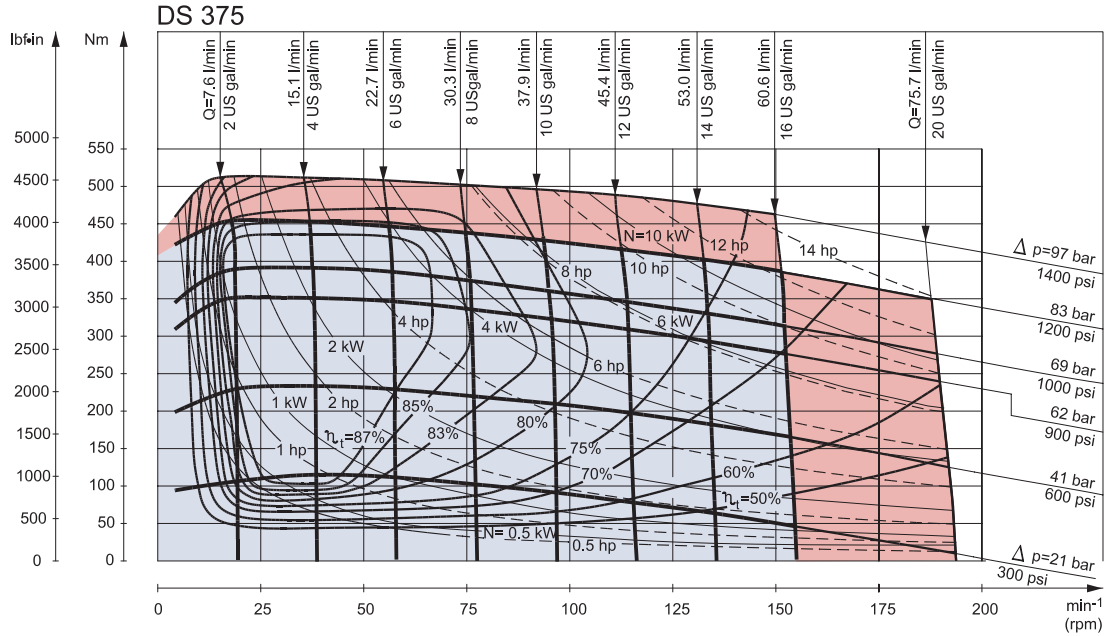

151-1882.10

Explanation of function diagram use, basis and conditions can be found on page 4.

- A: Continuous range
- B: Intermittent range (max. 10% operation every minute)

Max. permissible continuous/intermittent pressure drop for the actual shaft version can be found on page 24.

Intermittent pressure drop and oil flow must not occur simultaneously.

Technical Data

Shaft Version

US version

- A: Cylindrical shaft  
1 in
- C: Woodruff key  
1/4 x 1 in  
SAE J502

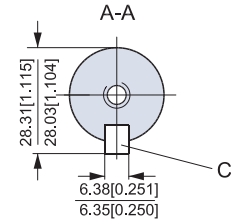
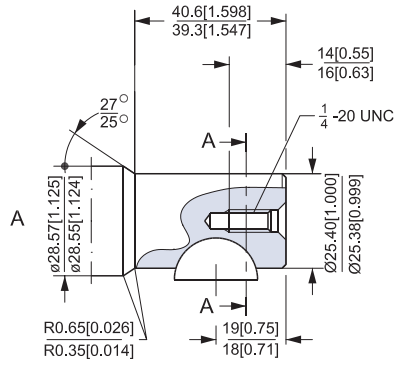

US version

- B: Splined shaft  
1 in - SAE 6B
- \* Deviates from B.S. 2059  
(SAE 6B)

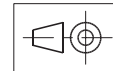
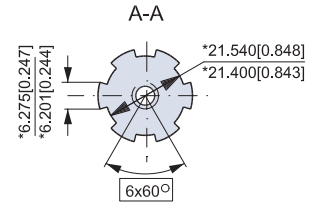
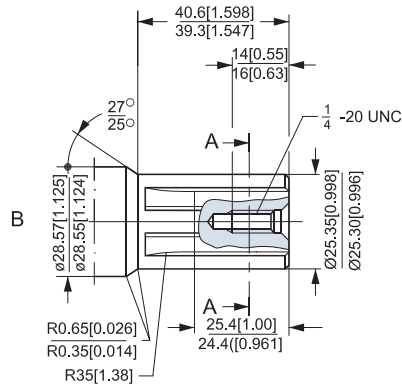

151-1876.10

6B splined shaft is recommended for operating torque of 280 Nm [2500 lbf-in] or more.

Technical Data

Port Thread Versions

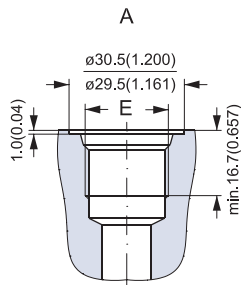

A: UNF main ports  
 E: 7/8 - 14 UNF  
 O-ring boss port

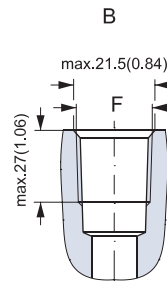

B: NPTF main ports  
 F: 1/2 - 14 NPTF

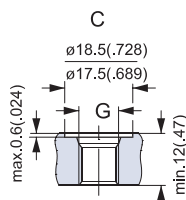

C: UNF drain port  
 G: 7/16 - 20 UNF  
 O-ring boss port

Dimensions

Dimensions – US Version

Side port version with 2 hole oval mounting flange (A2-flange).  
Port thread version.

Type	L mm [in]	L mm [in]
DS 50	125.6 [4.94]	9.0 [0.35]
DS 80	130.6 [5.14]	14.0 [0.55]
DS 100	130.6 [5.14]	14.0 [0.55]
DS 125	134.0 [5.28]	17.4 [0.69]
DS 160	138.4 [5.45]	21.8 [0.86]
DS 200	144.4 [5.69]	27.8 [1.09]
DS 250	151.4 [5.96]	34.8 [1.37]
DS 315	160.1 [6.30]	43.5 [1.71]
DS 375	171.4 [6.75]	54.8 [2.16]

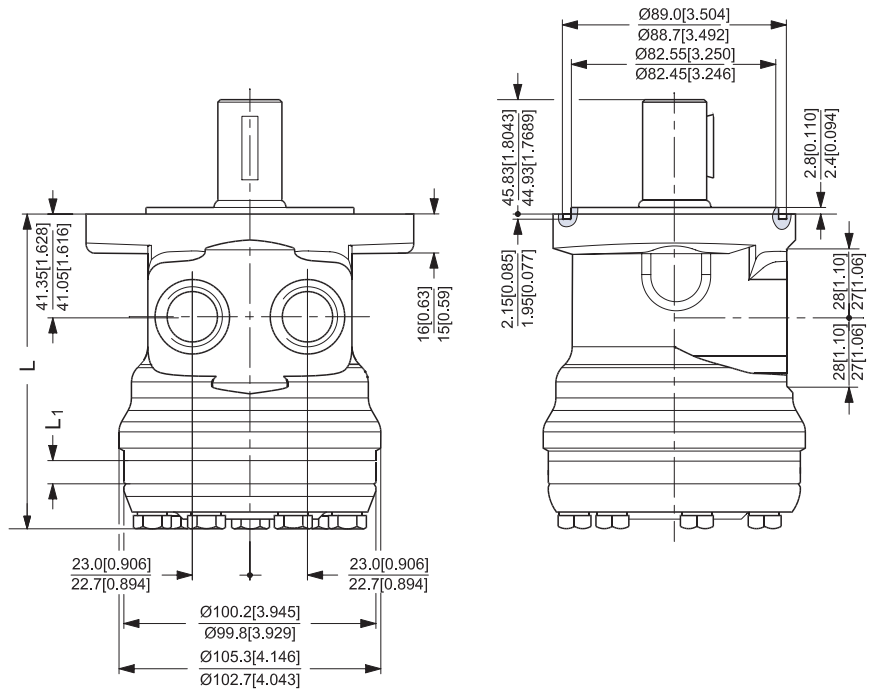

D: 7.8 - 14 UNF,  
16.7 mm [0.66 in] deep  
O-ring boss port or  
1/2 - 14 NPTF

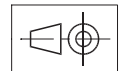
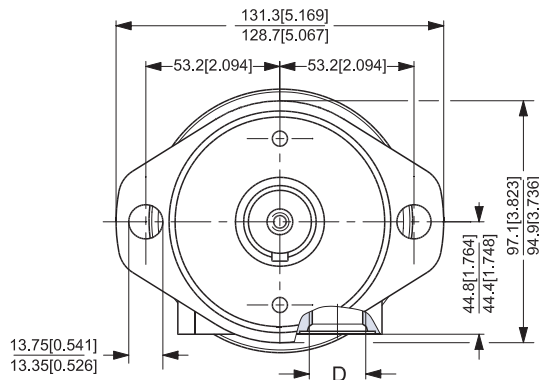

151-1898.10

Dimensions

Dimensions – US Version

Side port version with 2 hole oval mounting flange (A2-flange).  
With drain connection.  
Port thread version.

Type	L mm [in]	L mm [in]
DS 50	125.6 [4.94]	9.0 [0.35]
DS 80	130.6 [5.14]	14.0 [0.55]
DS 100	130.6 [5.14]	14.0 [0.55]
DS 125	134.0 [5.28]	17.4 [0.69]
DS 160	138.4 [5.45]	21.8 [0.86]
DS 200	144.4 [5.69]	27.8 [1.09]
DS 250	151.4 [5.96]	34.8 [1.37]
DS 315	160.1 [6.30]	43.5 [1.71]
DS 375	171.4 [6.75]	54.8 [2.16]

C: 7/16 - 20 UNF,  
12 mm [0.47 in] deep  
D: 7/8 - 14 UNF,  
16.7 mm [0.66 in] deep  
O-ring boss port or  
1/2 - 14 NPTF

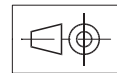
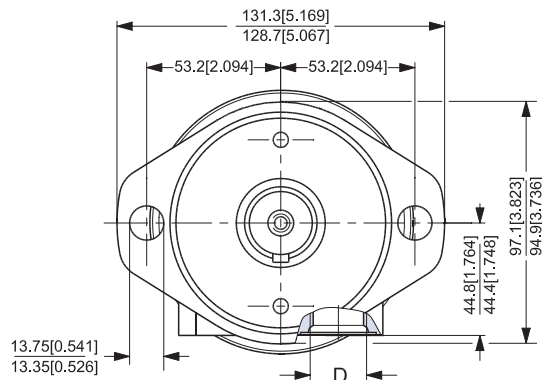
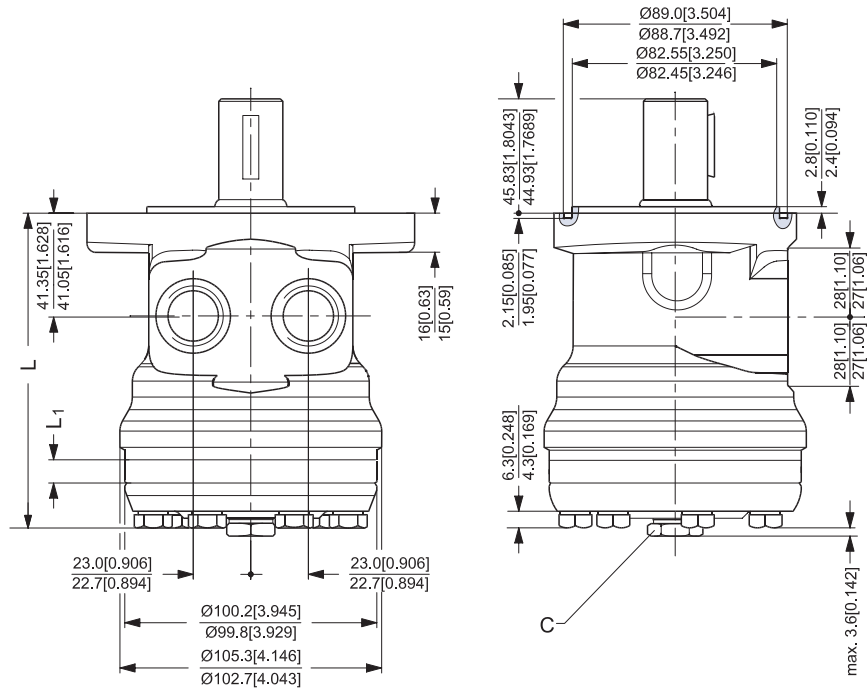

151-1899.10

Dimensions

Dimensions – US Version

Side port version with square mounting flange (C-flange).  
Port thread version.

Type	L mm [in]	L mm [in]
DS 50	125.6 [4.94]	9.0 [0.35]
DS 80	130.6 [5.14]	14.0 [0.55]
DS 100	130.6 [5.14]	14.0 [0.55]
DS 125	134.0 [5.28]	17.4 [0.69]
DS 160	138.4 [5.45]	21.8 [0.86]
DS 200	144.4 [5.69]	27.8 [1.09]
DS 250	151.4 [5.96]	34.8 [1.37]
DS 315	160.1 [6.30]	43.5 [1.71]
DS 375	171.4 [6.75]	54.8 [2.16]

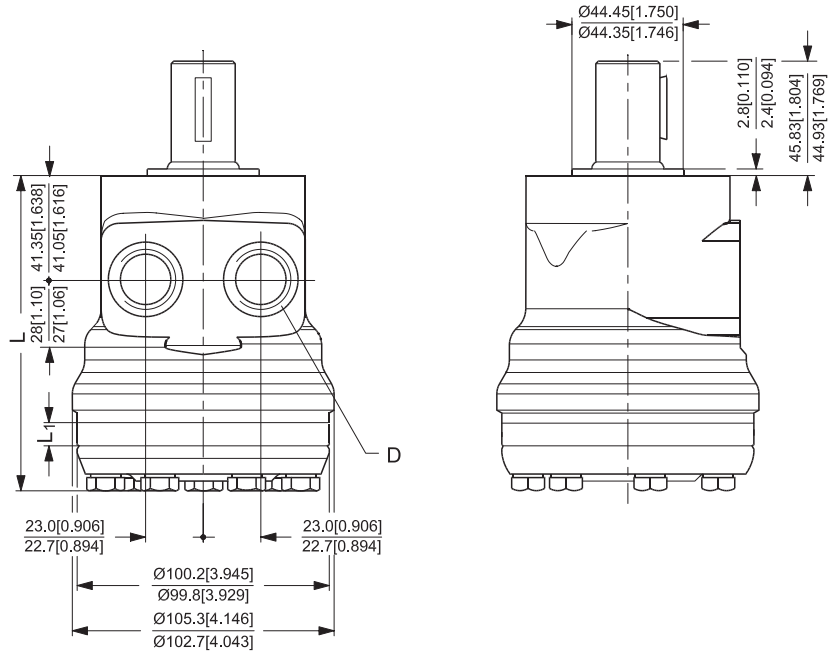

D: 7.8 - 14 UNF;  
16.7 mm [0.66 in] deep  
or 1/2 - 14 NPTF  
E: 3.8 - 16 UNC;  
15 mm [0.59 in] deep  
(4-off)

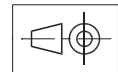
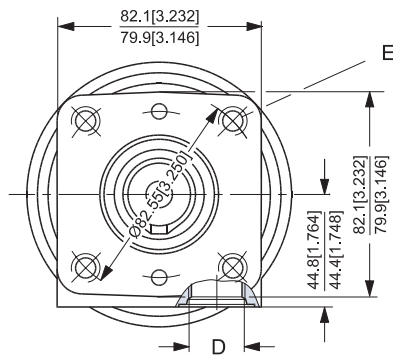

151-1897.10

**Hydraulic Systems**
**Installation of the Orbital Motors**
*About the design*

- To ensure efficient operation all hydraulic components must be installed according to their individual instructions.
- The pump line must include a gage connection.
- To ensure designed contact and minimize the stress all mounting flanges must be flat.
- Hydraulic lines must be fitted correctly to prevent air entrapment.

*About the assembly*

- Follow the mounting instructions printed on the inside of the cardboard box.
- To prevent contamination, do not remove the plastic plugs from the connection ports until the fittings are ready to be assembled.
- Check that there is full face contact between the motor mounting flange and the mating part.
- Do not force the motor into place when tightening the mounting screws.
- Avoid unsuitable sealing material on fittings such as pack twine, Teflon and others.
- Use only bonded seals, O-rings, steel washers and the like.
- When tightening the fittings never use a torque higher than the max. tightening torque stated in the instructions.
- Make sure that the cleanliness of the oil used is better than 20/16 (ISO 4406). Always use a filter for oil refilling.

**Starting Up and Running in the Hydraulic System**

- Through a small-meshed filter fill up the tank with oil to the upper oil level mark .
- Start the drive engine, and if possible, let it work at its lowest speed. If the motor is provided with bleed screws, keep these open until the emerging oil is non-foaming.
- Check that all components are correctly connected (pump following the right direction of rotation etc.).
- In load-sensing systems, also make sure that the signal lines are free of entrapped air.
- Indications of air in the hydraulic system:
  - foam in the tank
  - jerky movements of motor and cylinder
  - noise
- If required, refill with oil.
- Connect the system to a separate tank that includes a filter (fineness max. 10 µm) with twice the capacity of the max. oil flow. Let the entire system run without load (no pressure) for about 30 minutes.
- Do not load the system until it is all bled and clean.
- Check the tightness of the system and make sure that its performance is satisfactory.
- Change the oil filter, and if required, refill with oil.

**Operation**

- Do not expose the motor to pressures, pressure drops and speeds above the max. values stated in the catalogue.
- Filter the oil to ensure that the contamination level 20/16 (ISO 4406) or better.

**Maintenance**

- When working with hydraulic systems, the main criteria of operating safety and endurance is careful maintenance
- Always renew and replace oil, oil filters and air filters according to the instructions given by the respective manufacturers
- Regularly check the condition of the oil
- Frequently check system tightness and oil level

Weight of Motors

Code no	Weight	
	kg	[lb]
151-2000	5.1	11.2
151-2001	5.1	11.2
151-2002	5.2	11.5
151-2003	5.4	11.9
151-2004	5.5	12.1
151-2005	5.7	12.6
151-2006	5.9	13.0
151-2007	6.1	13.4
151-2008	6.4	14.1
151-2009	6.9	15.2
151-2010	5.1	11.2
151-2011	5.1	11.2
151-2012	5.2	11.5
151-2013	5.4	11.9
151-2015	5.7	12.6
151-2016	5.9	13.0
151-2017	6.1	13.4
151-2018	6.4	14.1
151-2019	6.9	15.2
151-2040	4.8	10.6
151-2041	4.8	10.6
151-2042	4.9	10.8
151-2043	5.1	11.2
151-2044	5.2	11.5
151-2045	5.4	11.9
151-2046	5.6	12.3
151-2047	5.8	12.8
151-2048	6.1	13.4
151-2049	6.6	14.6
151-2080	5.1	11.2
151-2081	5.1	11.2
151-2082	5.2	11.5
151-2083	5.4	11.9

Code no	Weight	
	kg	[lb]
151-2085	5.7	12.6
151-2086	5.9	13.0
151-2087	6.1	13.4
151-2088	6.4	14.1
151-2089	6.9	15.2
151-2120	4.8	10.6
151-2121	4.8	10.6
151-2122	4.9	10.8
151-2123	5.1	11.2
151-2124	5.2	11.5
151-2125	5.4	11.9
151-2126	5.6	12.3
151-2127	5.8	12.8
151-2128	6.1	13.4
151-2129	6.6	14.6
151-2301	5.9	13.0
151-2302	6.1	13.4
151-2303	6.1	13.4
151-2304	6.2	13.7
151-2305	6.4	14.1
151-2306	6.7	14.8
151-2307	7.2	15.9
151-2308	7.7	17.0
151-2309	8.2	18.1
151-2312	6.1	13.4
151-2313	6.1	13.4
151-2314	6.2	13.7
151-2316	6.7	14.8
151-2318	7.7	11.2
151-2319	8.2	11.7
151-2341	5.6	12.3
151-2342	5.8	12.8
151-2343	5.8	12.8

Code no	Weight	
	kg	[lb]
151-2344	5.9	13.0
151-2345	6.1	13.4
151-2346	6.4	14.1
151-2347	6.9	15.2
151-2348	7.4	16.3
151-2349	7.9	17.4
151-2382	6.1	13.4
151-2383	6.1	13.4
151-2385	6.4	14.1
151-2386	6.7	14.8
151-2387	7.2	15.9
151-2389	8.2	18.1
151-2421	5.6	12.3
151-2423	5.8	12.8
151-2425	6.1	13.4
151-2426	6.4	14.1
151-2427	6.9	15.2
151-2429	7.9	17.4
151-3401	5.1	11.2
151-3402	5.2	11.5
151-3403	5.4	11.9
151-3407	6.1	13.4
151-3408	6.4	14.1
151-3409	6.9	15.2
151-3702	6.1	13.4
151-3703	6.1	13.4
151-3704	6.2	13.7
151-3706	6.7	14.8
151-3707	7.2	15.9
151-3708	7.7	17.0