

Technical Information

OML and OMM Orbital Motors



OIL SOLUTIONS

PO Box 38

Strathfieldsaye, VIC, 3551

1800 OIL SOL

1800 645 765

sales@oilsolutions.com.au

www.oilsolutions.com.au

"For All Your Hydraulic Needs"

Contents

Chapter 1: Speed, torque and output.....	5
Speed, torque and output.....	6
Chapter 2: OML.....	7
Versions.....	8
OML versions.....	8
Code numbers.....	8
Technical data.....	8
Technical data for OML with 16 mm and 5/8 in cylindrical shaft.....	8
Shaft seal.....	10
Max. permissible shaft seal pressure.....	10
Oil flow.....	11
Direction of shaft rotation.....	11
Shaft load.....	11
Permissible shaft loads for OML.....	11
Function diagram.....	12
Function diagrams.....	12
Shaft.....	14
Shaft version.....	14
Port.....	15
Port thread versions.....	15
Dimensions.....	16
OML end port, European version.....	16
OML end port, US version.....	17
Chapter 3: OMM.....	19
Versions.....	20
OMM versions.....	20
Code numbers.....	20
Technical data.....	21
Technical data for OMM with 16 mm and 5/8 in cylindrical shaft.....	21
Shaft seal.....	22
Max. permissible shaft seal pressure.....	22
Oil flow.....	23
Direction of shaft rotation.....	23
Shaft load.....	23
Permissible shaft loads for OMM.....	23
Function diagram.....	24
Function diagrams.....	24
Shaft.....	27
Shaft version.....	27
Port.....	28
Port thread versions.....	28
Dimensions.....	29
OMM end port, European version.....	29
OMM end port, US version.....	31
OMM side port, European version.....	33

OMM side port, US version..... 35

Chapter 4: Accessories.....37

2 bolt flange kit, code no. 151G0211..... 38

Chapter 5: Hydraulic systems.....39

Installation of the Orbital Motors..... 40

Starting up and running in the hydraulic system..... 40

Operation..... 40

Maintenance..... 40

Chapter

1

Speed, torque and output

Topics:

- *Speed, torque and output*

Speed, torque and output

The following bar diagrams, are useful for a quick selection of relevant motor size for the application. The final motor size can be determined by using the function diagram for each motor size.

- OML can be found under [function diagrams](#).
- OMM can be found under [function diagrams](#).

The function diagrams are based on actual tests on a representative number of motors from our production. The diagrams apply to a return pressure between 5 and 10 bar [75 and 150 psi] when using mineral based hydraulic oil with a viscosity of 35 mm²/s [165 SUS] and a temperature of 50°C [120°F]. For further explanation concerning how to read and use the function diagrams, please consult the paragraph "Selection of motor size" in the technical information "General" DKMH.PK.100.G2.02 BC152886483554.

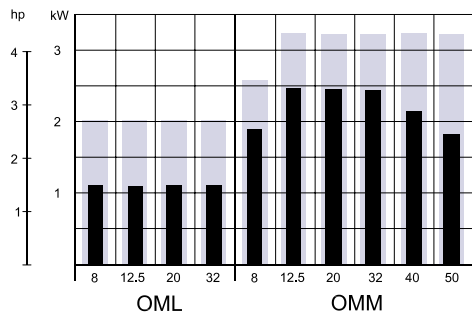
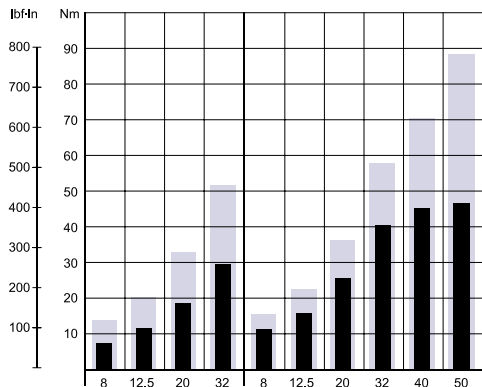
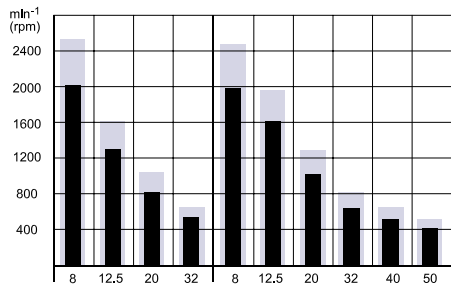

OML

OMM



Chapter

2

OML

Topics:

- *Versions*
 - *Technical data*
 - *Shaft seal*
 - *Oil flow*
 - *Shaft load*
 - *Function diagram*
 - *Shaft*
 - *Port*
 - *Dimensions*
-

Versions

OML versions

Mounting	Shaft	Port size	European version	US version	Side port version	End port version	Standard shaft seal	Drain connection	Check valve	Main type designation	Config. code
Front, 4 × M5	Cyl. 16 mm	G 1/4	X			X	X	No	Yes	OML	1
Front, 4 × 10-32 UNF	Cyl. 5/8 in	7/16 - 20 UNF		X		X	X	No	Yes	OML	2

Features available (options) :

Painted

Code numbers

Config. code	Code number - displacement (cm ³)			
	8	12.5	20	32
1	2001	2002	2003	2004
2	2021	2022	2023	2024

Ordering

Add the four digit prefix “151G” to the four digit numbers from the chart for complete code number.

Example:

151G2001 for an OML 8 with front mounting (4 × M5), cyl. 16 mm shaft and port size G 1/4.

Note: Orders will not be accepted without the four digit prefix.

Technical data

Technical data for OML with 16 mm and 5/8 in cylindrical shaft

Type		OML 8	OML 12.5	OML 20	OML 32
Motor Size		8	12.5	20	32
Geometric displacement	cm ³	8.0	12.5	20.0	32.0
	[in ³]	[0.49]	[0.77]	[1.22]	[1.96]

Type			OML	OML	OML	OML
Motor Size			8	12.5	20	32
Max. speed	min ⁻¹	cont.	2000	1280	800	500
	[rpm]	int. ¹⁾	2500	1600	1000	625
Max. torque	Nm	cont.	7	11	18	29
	[lb•in]		[60]	[100]	[160]	[260]
		int. ¹⁾	13	20	32	51
			[120]	[180]	[280]	[450]
Max. output	kW	cont.	1.1	1.1	1.1	1.1
	[hp]		[1.5]	[1.5]	[1.5]	[1.5]
		int. ¹⁾	2.0	2.0	2.0	2.0
			[2.7]	[2.7]	[2.7]	[2.7]
Max. pressure drop	bar	cont.	70	70	70	70 (55) ³
	[psi]		[1020]	[1020]	[1020]	[1020] [800] ³
		int. ¹⁾	125	125	125 (85) ³	125 (55) ³
			[1810]	[1810]	[1810] [800] ³	[1810] [800] ³
		peak ²⁾	140	140	125 (85) ³	140 (55) ³
			[2030]	[2030]	[2030] [1230] ³	[2030] [800] ³
Max. oil flow	l/min	cont.	16	16	16	16
	[US gal/ min]		[4.2]	[4.2]	[4.2]	[4.2]
		int. ¹⁾	20	20	20	20
			[5.3]	[5.3]	[5.3]	[5.3]
Max. starting pressure with unloaded shaft	bar		4	4	4	6
	[psi]		[60]	[60]	[60]	[90]
Min. starting torque	at max. press. drop	cont.	5	9	15	24
	Nm [lb•in]		[45]	[80]	[135]	[210]
	at max. press. drop	int. ¹⁾	10	16	27	42
	Nm [lb•in]		[90]	[140]	[240]	[370]
Min. speed ⁴⁾	min ⁻¹		50	50	50	50
	[rpm]					

Type	Max. inlet pressure		
OML 8 - 32	bar [psi]	cont.	125 [1810]
		int. ¹⁾	140 [2030]
		peak ²⁾	140 [2030]

¹⁾ Intermittent operation: the permissible values may occur for max. 10% of every minute.

²⁾ Peak load: the permissible values may occur for max. 1% of every minute.

³⁾ Max. pressure drop in applications with a large moment of inertia and frequent stops or reversings.

⁴⁾ Operation at lower speed may be slightly less smooth.

Shaft seal

Max. permissible shaft seal pressure

Figure 1: OML has incorporated check valves

which ensure that the pressure on the shaft seal never exceeds the pressure in the returnline.

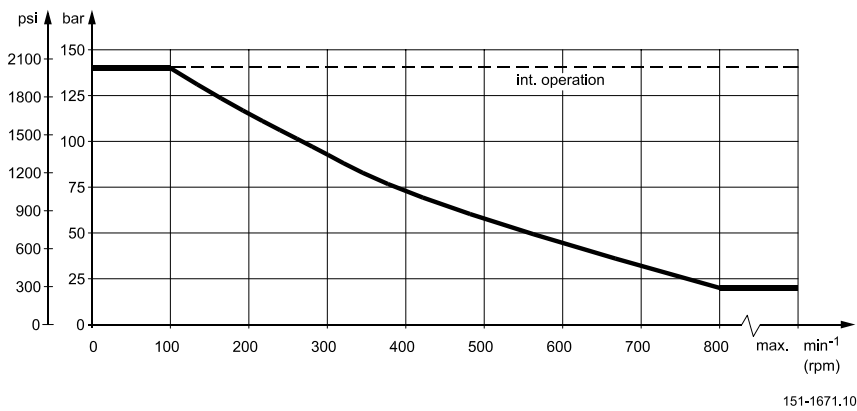
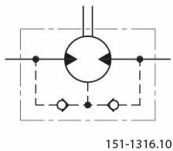

Figure 2: Max. return pressure (max. pressure on shaft seal)

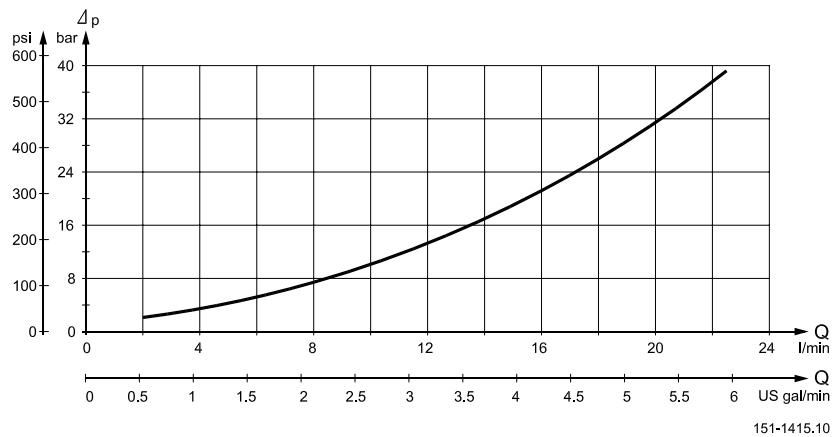
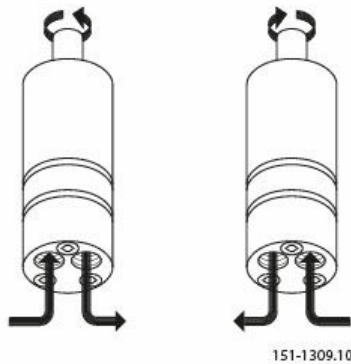

Figure 3: Pressure Drop in Motor

The curve applies to an unloaded motor shaft and an oil viscosity of 35 mm²/s [165 SUS]

Oil flow

Direction of shaft rotation



Shaft load

Permissible shaft loads for OML

The permissible radial shaft load ($P_{rad.}$) is calculated from the distance (l) between the point of load and the mounting surface:

$$P_{rad.} = \frac{84500}{64.5 + l} \text{ N (l in mm; } l \leq 80)$$

$$P_{rad.} = \frac{748}{254 + l} \text{ lbf (l in inch; } l \leq 3.15)$$

The drawing shows the permissible radial load when $l = 15 \text{ mm [0.59 in]}$.

The calculated shaft load should never exceed the permissible value.

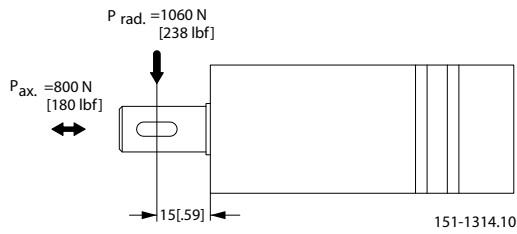

Function diagram

Function diagrams

Explanation of function diagram use, basis and conditions can be found under [Speed, torque and output](#).

- A: Continuous range
- B: Intermittent range (max. 10% operation every minute)

Max. permissible continuous/intermittent pressure drop for the actual shaft version can be found under [Technical data](#).

Note:

Intermittent pressure drop and oil flow must not occur simultaneously.

OML 8 function diagram

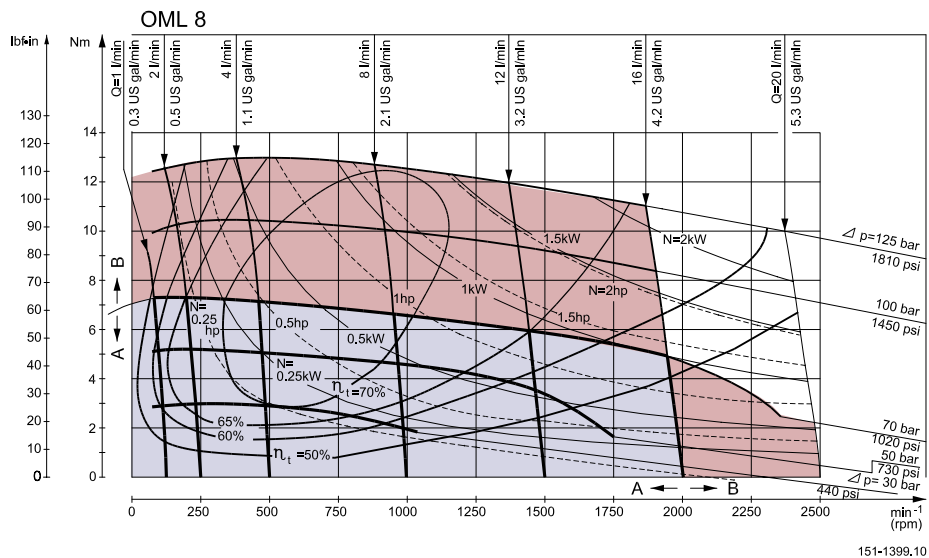

OML 12.5 function diagram

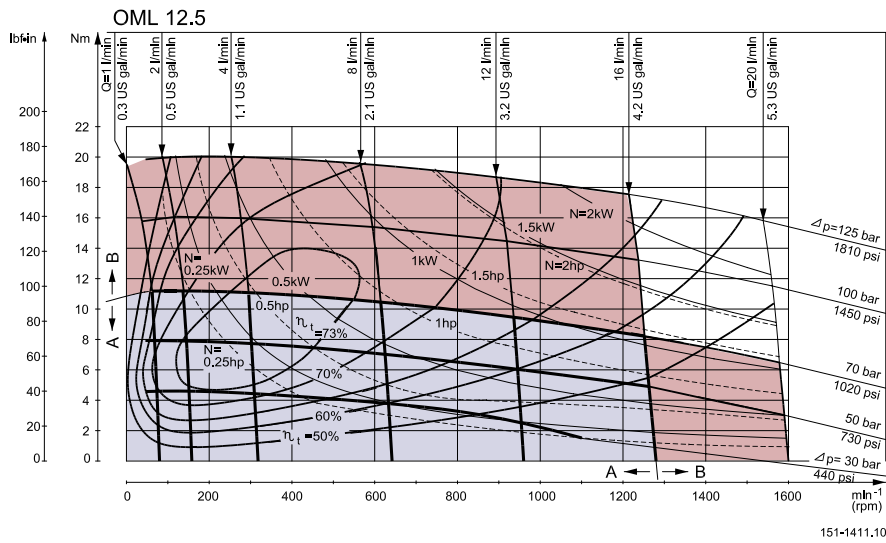

OML 20 function diagram

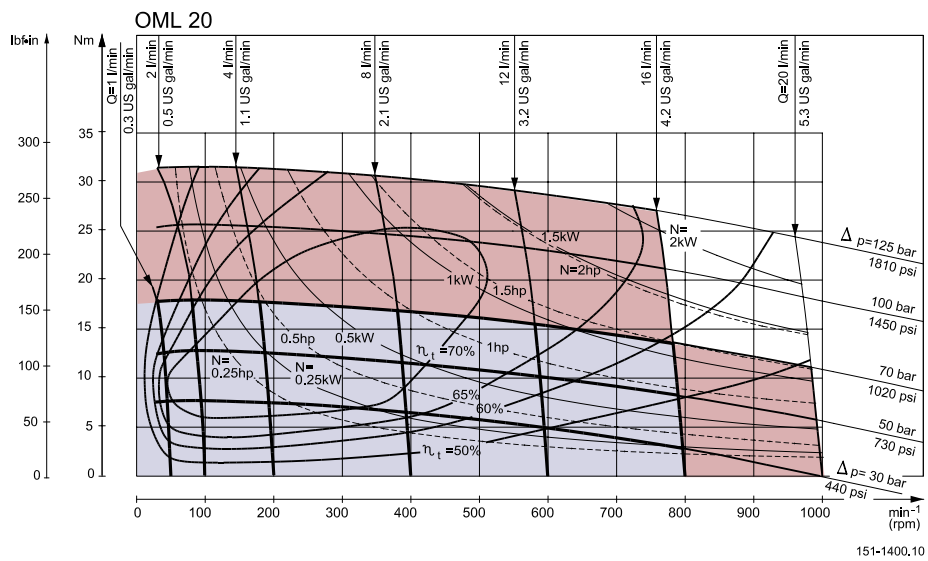

OML 32 function diagram

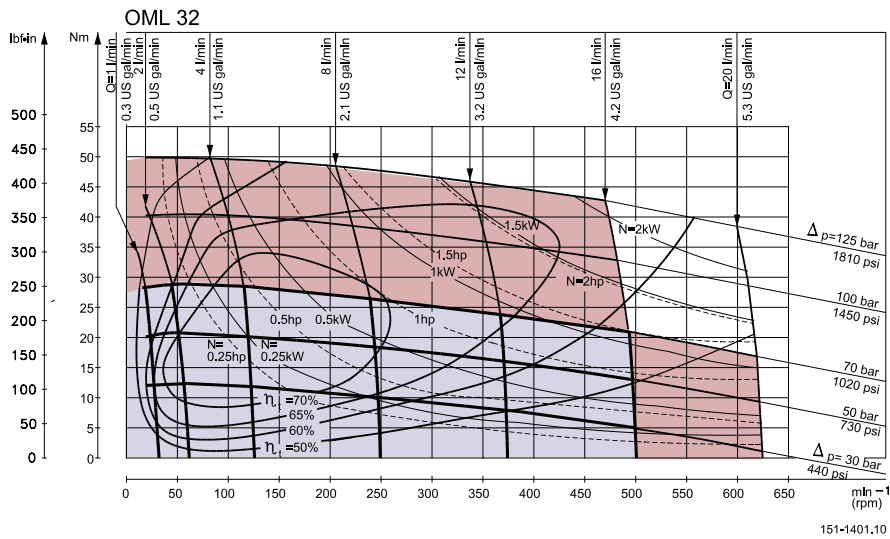

Shaft

Shaft version

A: Cylindrical shaft

16 mm

C: Parallel key

A5 × 5 × 16

DIN 6885

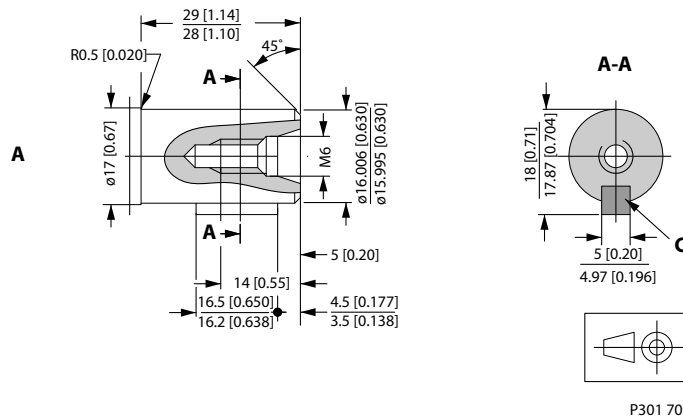

P301 709

US version

B: Cylindrical shaft

5/8"

D: Parallel key

3/16 × 3/16 × 3/4 in

B.S. 46

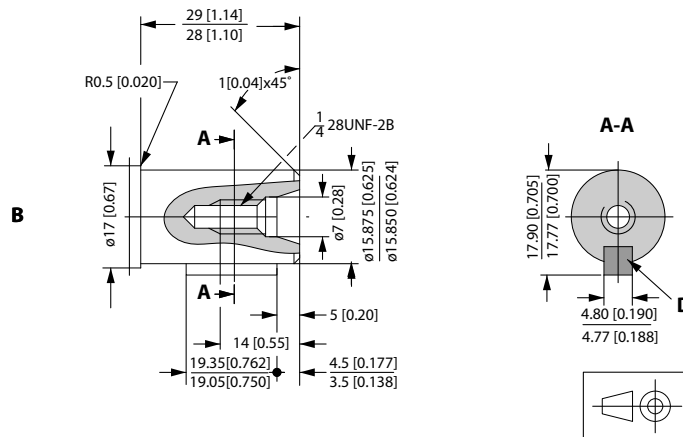

P301 710

Port

Port thread versions

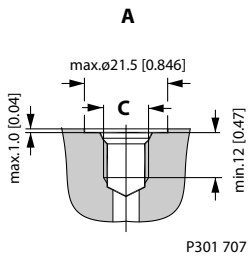

A: G main ports
C: ISO 228/1 - G1/4

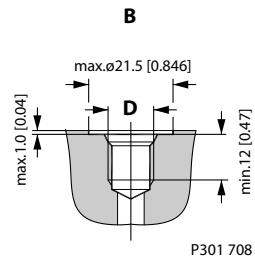

B: UNF main ports
D: 7/16 - 20 UNF
O-ring boss port

Dimensions

OML end port, European version

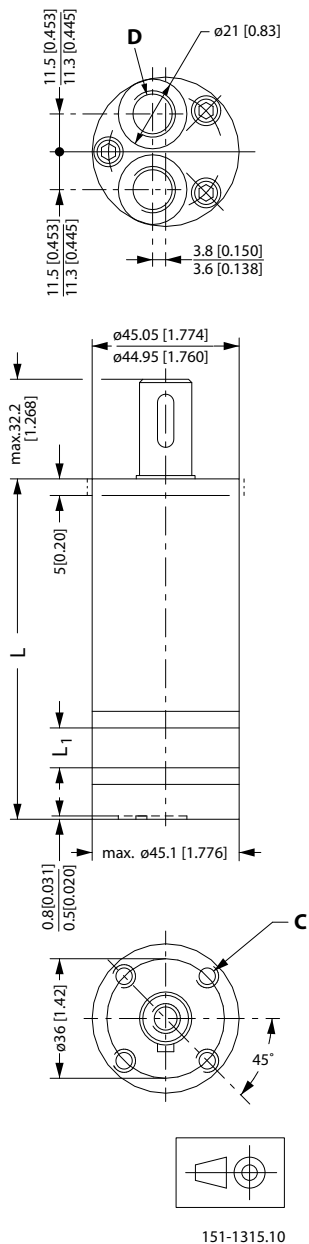

C: M5; 15 mm [0.59 in] deep

D: G 1/4; 12 mm [0.47 in]

Weight and dimensions

Type	Length		Weight kg [lb]
	L_{max}	L_1 mm [in]	
OML 8	102.5 [4.04]	4.1 [0.16]	1.0 [2.2]

Type	Length		Weight kg [lb]
	L _{max.}	L ₁ mm [in]	
OML 12.5	104.8 [4.13]	6.4 [0.25]	1.0 [2.2]
OML 20	108.6 [4.28]	10.2 [0.40]	1.1 [2.4]
OML 32	114.7 [4.53]	16.3 [0.64]	1.2 [2.6]

OML end port, US version

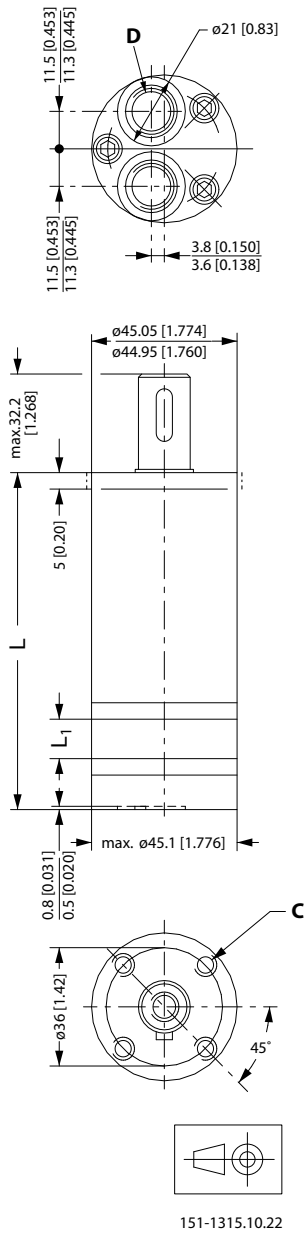

C: 10 - 32 UNF; 15 mm [0.59 in] deep

D: 7/16 - UNF; 12 mm [0.47 in] deep

Weight and dimensions

Type	Length		Weight kg [lb]
	L _{max.}	L ₁ mm [in]	
OML 8	102.5 [4.04]	4.1 [0.16]	1.0 [2.2]
OML 12.5	104.8 [4.13]	6.4 [0.25]	1.0 [2.2]
OML 20	108.6 [4.28]	10.2 [0.40]	1.1 [2.4]
OML 32	114.7 [4.53]	16.3 [0.64]	1.2 [2.6]

Chapter

3

OMM

Topics:

- *Versions*
 - *Technical data*
 - *Shaft seal*
 - *Oil flow*
 - *Shaft load*
 - *Function diagram*
 - *Shaft*
 - *Port*
 - *Dimensions*
-

Versions

OMM versions

Mounting	Shaft	Port size	European version	US version	Side port version	End port version	Standard shaft seal	Drain connection	Check valve	Main type designation	Config. code
Front; 3 × M6	Cyl. 16 mm	G 3/8	X			X	X	Yes	Yes	OMM	1
		G 3/8	X		X		X	Yes	Yes	OMM	2
Front; 3 × 1/4 - 28 UNF	Cyl. 5/8 in	9/16-18 UNF		X		X	X	Yes	Yes	OMM	3
		9/16-18 UNF		X	X		X	Yes	Yes	OMM	4
Front; 3 × M6	Splined B17×14	G 3/8	X			X	X	Yes	Yes	OMM	5
		G 3/8	X		X		X	Yes	Yes	OMM	6

Features available (options) :

- Speed sensor
- Reverse rotation
- Corrosion protected
- Painted
- 2 bolt flange kit (Code no 151G0211)

Code numbers

Config. code	Code numbers, displacement (cm ³)					
	8	12.5	20	32	40	50
1	0040	0001	0002	0003	0277	0037
2	0041	0004	0005	0006	0279	0013
3	0048	0031	0032	0033	-	5032
4	0049	0034	0035	0036	-	0094
5	0046	0024	0025	0026	-	-
6	0047	0027	0028	0029	0294	-

Ordering

Add the four digit prefix “151G” to the four digit numbers from the chart for complete code number.

Example:

151G0035 for an OMM 20 with front mounting (3 × 1/4 - 28 UNF), cyl. 5/8 in shaft and port size 9/16 - 18 UNF.

Note:

Orders will not be accepted without the four digit prefix.

Technical data

Technical data for OMM with 16 mm and 5/8 in cylindrical shaft

Type			OMM	OMM	OMM	OMM	OMM	OMM
Motor size			8	12.5	20	32	40	50
Geometric displacement	cm ³		8.2	12.5	19.9	31.6	39.8	70
	[in ³]		[0.50]	[0.77]	[1.22]	[1.93]	[2.43]	[4.27]
Max. speed	min ⁻¹	cont.	1950	1550	1000	630	500	400
	[rpm]	int. ¹⁾	2450	1940	1250	800	630	500
Max. torque	Nm	cont.	11	16	25	40	45	46
			[95]	[140]	[220]	[350]	[400]	[410]
		int. ¹⁾	15	23	35	57	70	88
			[135]	[200]	[310]	[500]	[620]	[780]
Max. output	kW	cont.	1.8	2.4	2.4	2.4	2.2	1.8
			[2.4]	[3.2]	[3.2]	[3.2]	[3.0]	[2.4]
		int. ¹⁾	2.6	3.2	3.2	3.2	3.2	3.2
			[3.5]	[4.3]	[4.3]	[4.3]	[4.3]	[4.3]
Max. pressure drop	bar	cont.	100	100	100	100	90	70
			[1450]	[1450]	[1450]	[1450]	[1310]	[1020]
		int. ¹⁾	140	140	140	140	140	140
			[2030]	[2030]	[2030]	[2030]	[2030]	[2030]
		peak ²⁾	200	200	200	160	160	160
		[2900]	[2900]	[2900]	[2320]	[2320]	[2320]	
Max. oil flow	l/min	cont.	16	20	20	20	20	20
			[4.2]	[5.3]	[5.3]	[5.3]	[5.3]	[5.3]
	[US gal/ min]	int. ¹⁾	20	25	25	25	25	25
		[5.3]	[6.6]	[6.6]	[6.6]	[6.6]	[6.6]	

Type		OMM	OMM	OMM	OMM	OMM	OMM
Motor size		8	12.5	20	32	40	50
Max. starting pressure with unloaded shaft	bar	4	4	4	4	4	4
	[psi]	[60]	[60]	[60]	[60]	[60]	[60]
Min. starting torque	at max. press. drop cont.	7	12	21	34	38	41
		[60]	[105]	[185]	[300]	[335]	[365]
	Nm [lbf•in]	10	17	29	48	62	79
		[90]	[150]	[255]	[425]	[550]	[700]
Min. speed ³⁾	min ⁻¹	50	40	30	30	30	30
	[rpm]						
Type		Max. inlet pressure					
OMM 8 - 50	bar	cont.					140 [2030]
	[psi]	int. ¹⁾					175 [2538]
		peak ²⁾					225 [3260]

¹⁾ Intermittent operation: the permissible values may occur for max. 10% of every minute.

²⁾ Peak load: the permissible values may occur for max. 1% of every minute.

³⁾ Operation by lower speeds may be slightly less smooth.

Shaft seal

Max. permissible shaft seal pressure

Figure 4: OMM with check valves and without use of drain connection:

The pressure on the shaft seal never exceeds the pressure in the return line.

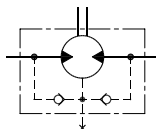

151-320.10

Figure 5: OMM with check valves and drain connection:

The shaft seal pressure equals the pressure on the drain line.

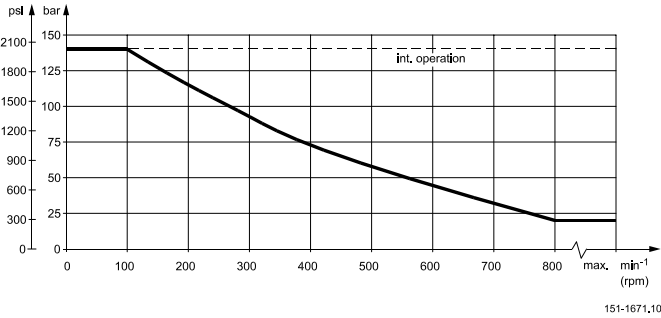

Figure 6: Max. return pressure without drain line or max. pressure in drain line

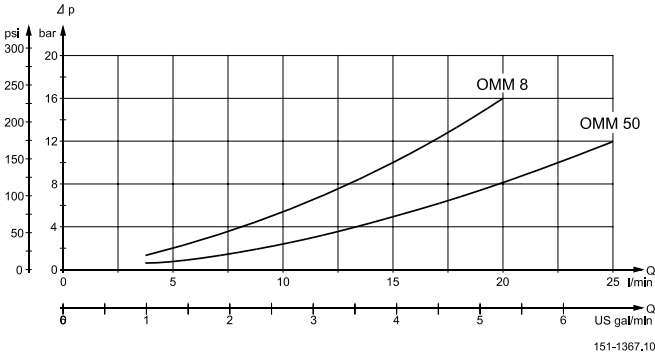
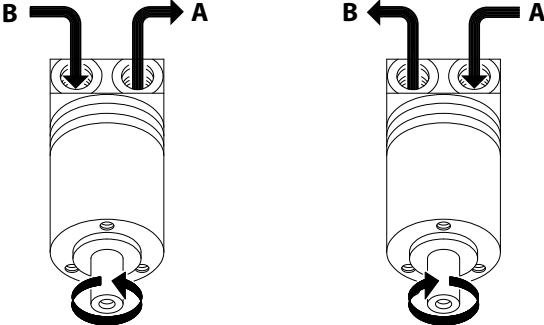

Figure 7: Pressure drop in motor

The curve applies to an unloaded motor shaft and an oil viscosity of 35 mm²/s [165 SUS]

Oil flow

Direction of shaft rotation



P301 008

Shaft load

Permissible shaft loads for OMM

The permissible radial shaft load (Prad.) is calculated from the distance (I) between the point of load and the mounting surface:

$$P_{rad} = \frac{130,400}{61.5 + l} \text{ N (l in mm; } l \leq 80 \text{ mm)}$$

$$P_{rad} = \frac{1,155}{2.42 + l} \text{ lbf (l in inch; } l \leq 3.15 \text{ in)}$$

The drawing shows the permissible radial load when $l = 20 \text{ mm [0.79 in]}$.

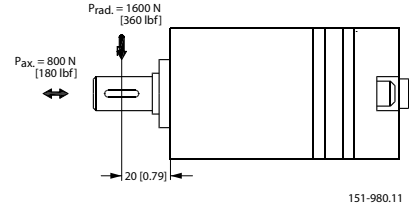

151-980.11

The calculated shaft load should never exceed the permissible value.

Function diagram

Function diagrams

Explanation of function diagram use, basis and conditions can be found under [Speed, torque and output](#).

- Light grey: Continuous range
- Light red: Intermittent range (max. 10% operation every minute)

Max. permissible continuous/intermittent pressure drop for the actual shaft version can be found under [Technical data](#).

Note:

Intermittent pressure drop and oil flow must not occur simultaneously.

OMM 8 function diagram

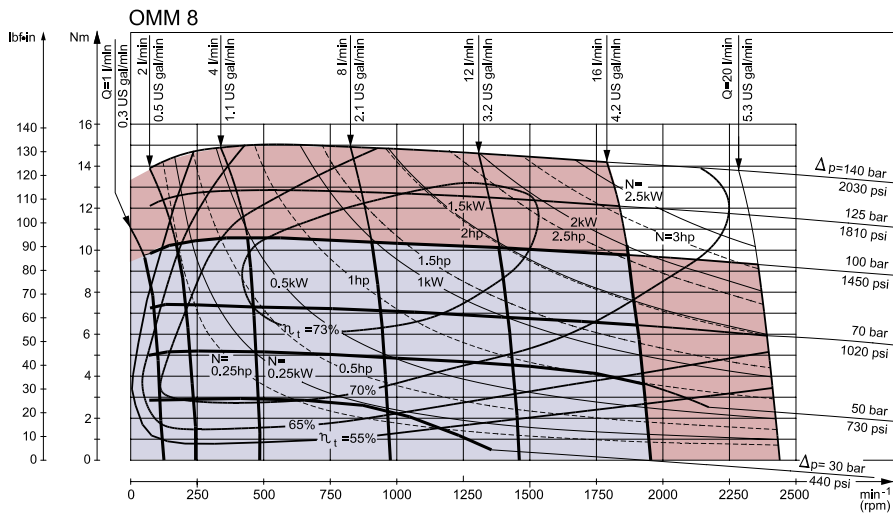

151-1117.11

OMM 12.5 function diagram

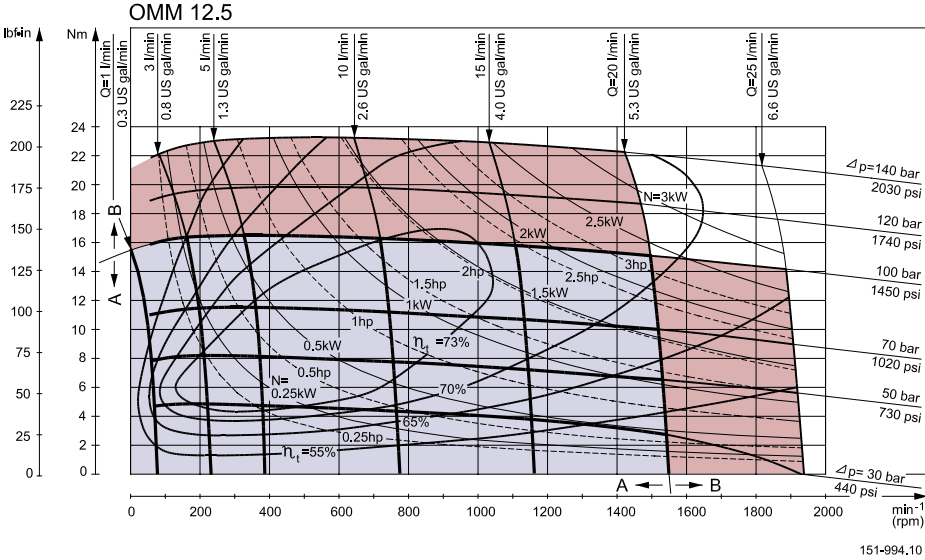

OMM 20 function diagram

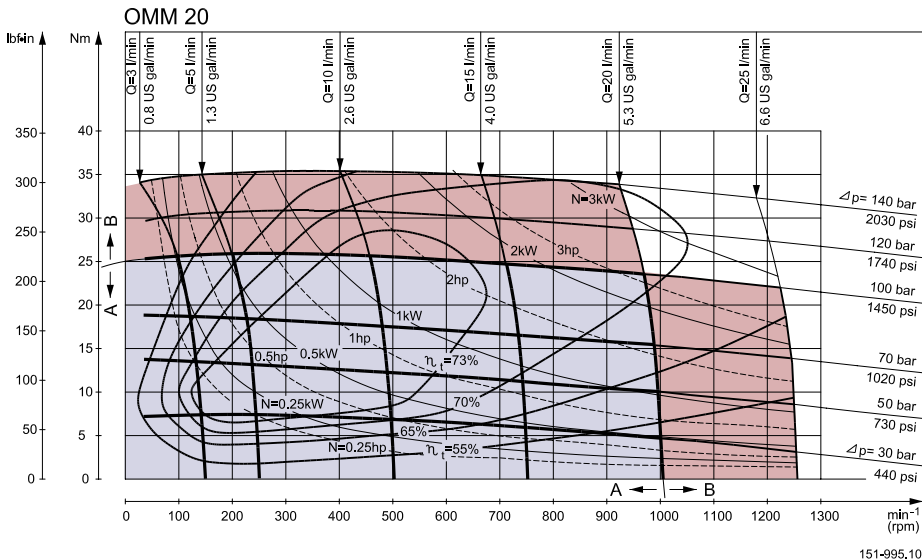

OMM 32 function diagram

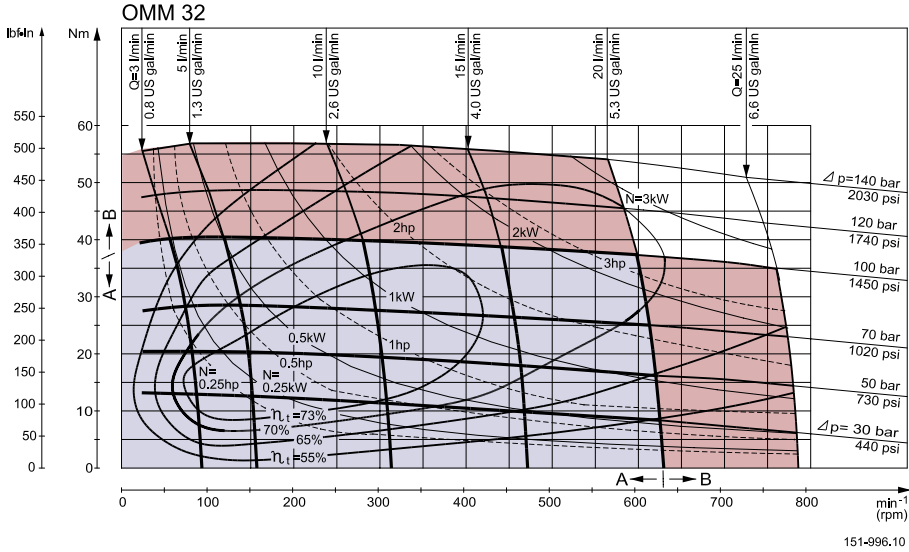

OMM 50 function diagram

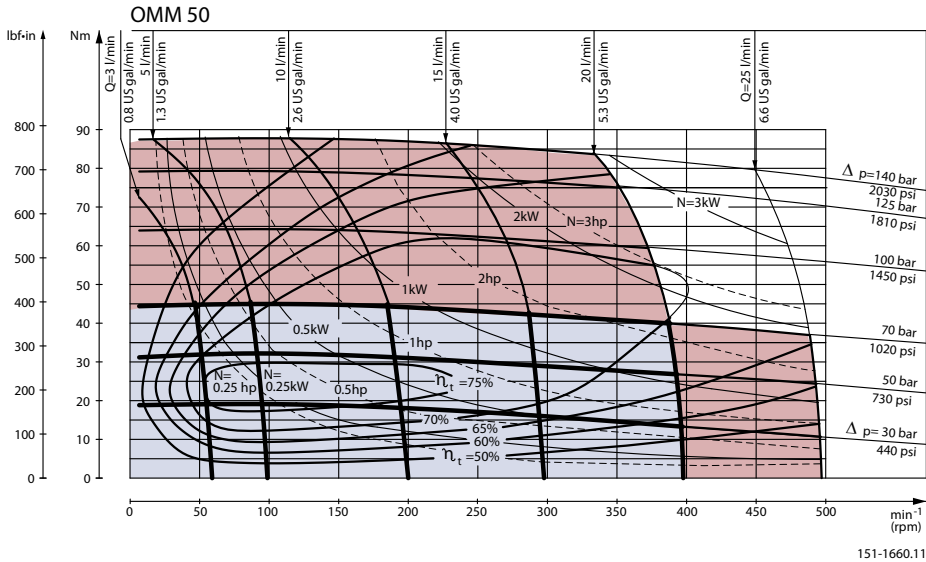

Shaft

Shaft version

- A:** Cylindrical shaft 16 mm [0.63 in]
- D:** Parallel key
- A5 • 5 • 16
- DIN 6885

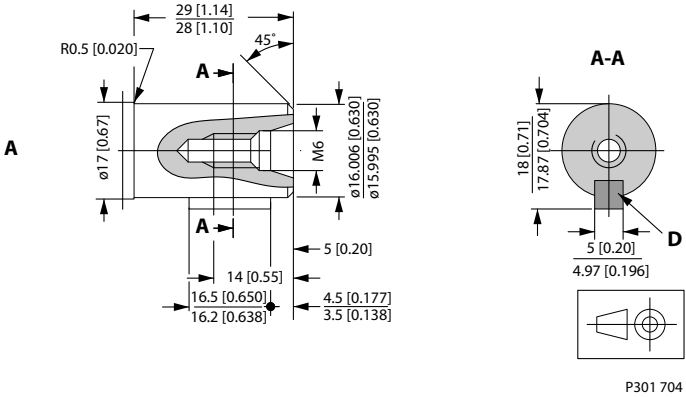

- US version**
- B:** Cylindrical shaft
- 5/8 in
- E:** Parallel key
- 3/16 • 3/16 • 3/4 in
- B.S. 46

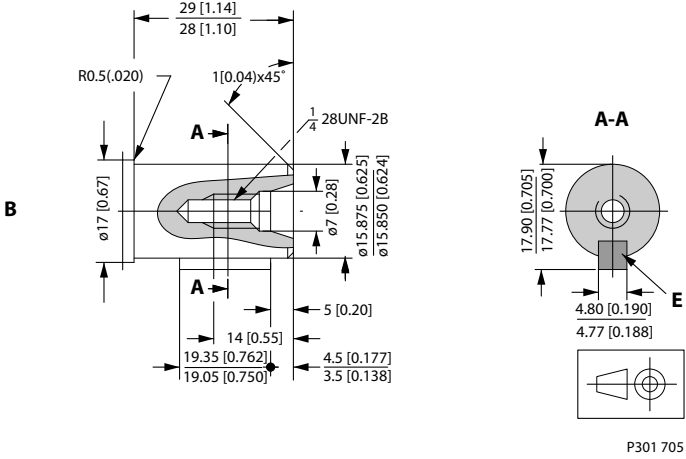

- C:** Involute splined shaft
- B17 • 14, DIN 5482
- Measurement 19.641 ± 0.04 mm over 3 mm pins deviates from
- DIN 5482

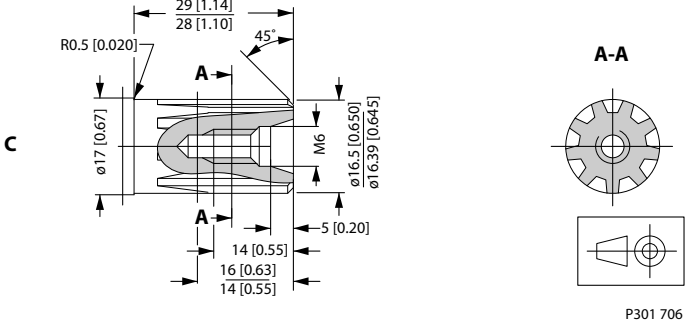

Port

Port thread versions

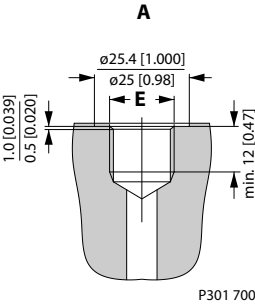

A: G main ports
E: ISO 228/1 - G3/8

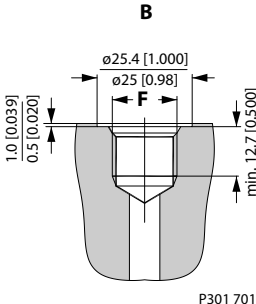

B: UNF main ports
F: 9/16 - 18 UNF O-ring boss port

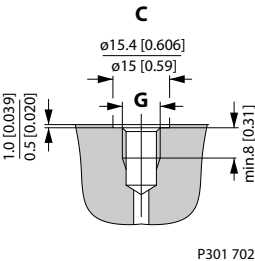

C: G drain ports
G: ISO 228/1 - G1/8

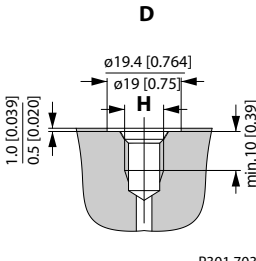

D: UNF drain ports
H: 3/8 - 24 UNF O-ring port

Dimensions

OMM end port, European version

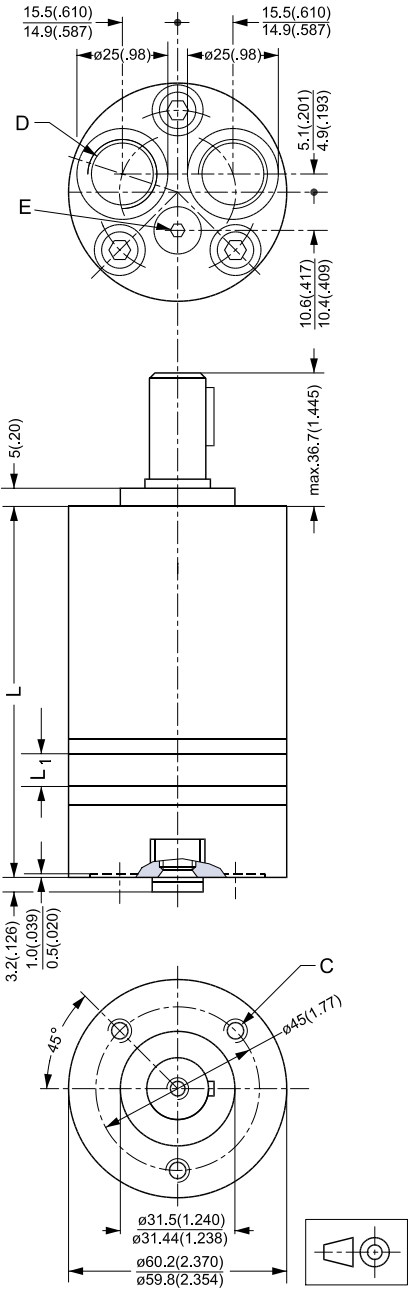

- C: M6; 10 mm [0.39 in] deep
- D: G 3/8; 12 mm [0.47 in] deep
- E: Drain connection G 1/8; 8 mm [0.39 in] deep

Weight and dimensions

Type	Length		Weight kg [lb]
	L max.	L1 mm [in]	
OMM 8	104.0 [4.09]	3.5 [0.14]	1.9 [4.2]
OMM 12.5	106.0 [4.17]	5.5 [0.22]	2.0 [4.4]
OMM 20	109.0 [4.29]	8.5 [0.33]	2.1 [4.6]
OMM 32	114.0 [4.49]	13.5 [0.53]	2.2 [4.8]
OMM 40	118.0 [4.65]	17.0 [0.67]	2.3 [5.1]
OMM 50	122.0 [4.80]	21.5 [0.85]	2.4 [5.3]

Weight and dimensions

Type	Length		Weight kg [lb]
	L max.	L1 mm [in]	
OMM 8	104.0 [4.09]	3.5 [0.14]	1.9 [4.2]
OMM 12.5	106.0 [4.17]	5.5 [0.22]	2.0 [4.4]
OMM 20	109.0 [4.29]	8.5 [0.33]	2.1 [4.6]
OMM 32	114.0 [4.49]	13.5 [0.53]	2.2 [4.8]
OMM 50	122.0 [4.80]	21.5 [0.85]	2.4 [5.3]

OMM side port, European version

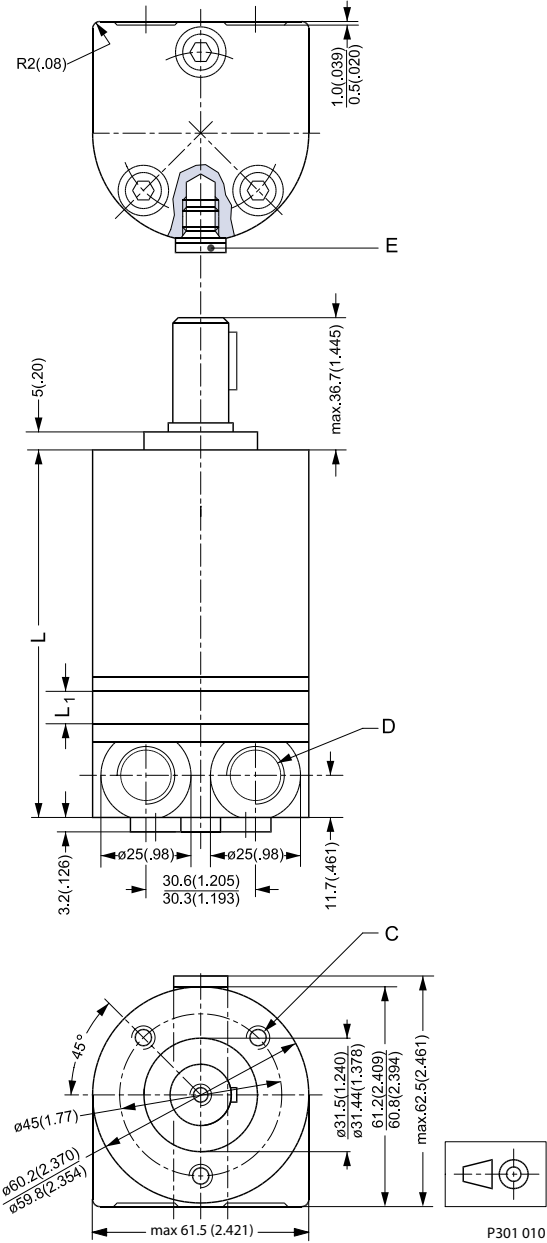

- C: M6; 10 mm [0.39 in] deep
- D: G 3/8; 12 mm [0.47 in] deep
- E: Drain connection G 1/8; 8 mm [0.39 in] deep

Weight and dimensions

Type	Length		Weight kg [lb]
	L max.	L1 mm [in]	
OMM 8	104.0 [4.09]	3.5 [0.14]	1.9 [4.2]

Type	Length		Weight kg [lb]
	L max.	L1 mm [in]	
OMM 12.5	106.0 [4.17]	5.5 [0.22]	2.0 [4.4]
OMM 20	109.0 [4.29]	8.5 [0.33]	2.1 [4.6]
OMM 32	114.0 [4.49]	13.5 [0.53]	2.2 [4.8]
OMM 40	118.0 [4.65]	17.0 [0.67]	2.3 [5.1]
OMM 50	122.0 [4.80]	21.5 [0.85]	2.4 [5.3]

OMM side port, US version

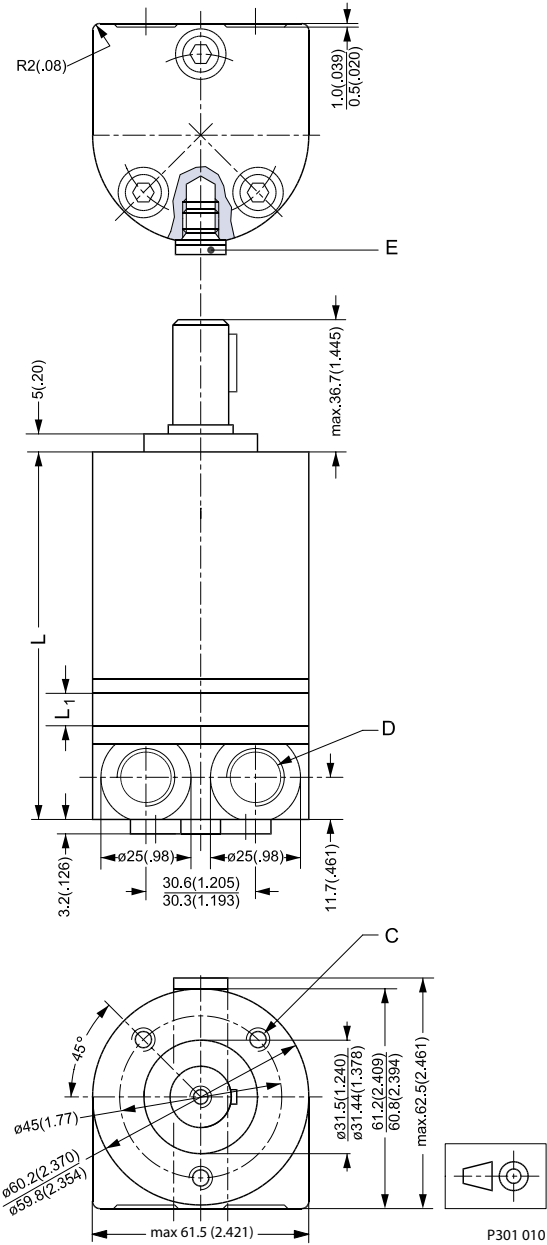

C: 1/4 - 28 UNF - 2B; min. 10 mm [0.39 in] deep

D: 9/16 - 18 UNF ; 12 mm [0.47 in] deep

E: 3/8 - 24 UNF ; 8 mm [0.39 in] deep

Weight and dimensions

Type	Length		Weight kg [lb]
	L max.	L1 mm [in]	
OMM 8	104.0 [4.09]	3.5 [0.14]	1.9 [4.2]

Type	Length		Weight kg [lb]
	L max.	L1 mm [in]	
OMM 12.5	106.0 [4.17]	5.5 [0.22]	2.0 [4.4]
OMM 20	109.0 [4.29]	8.5 [0.33]	2.1 [4.6]
OMM 32	114.0 [4.49]	13.5 [0.53]	2.2 [4.8]
OMM 50	122.0 [4.80]	21.5 [0.85]	2.4 [5.3]

Chapter

4

Accessories

Topics:

- *2 bolt flange kit, code no. 151G0211*

2 bolt flange kit, code no. 151G0211

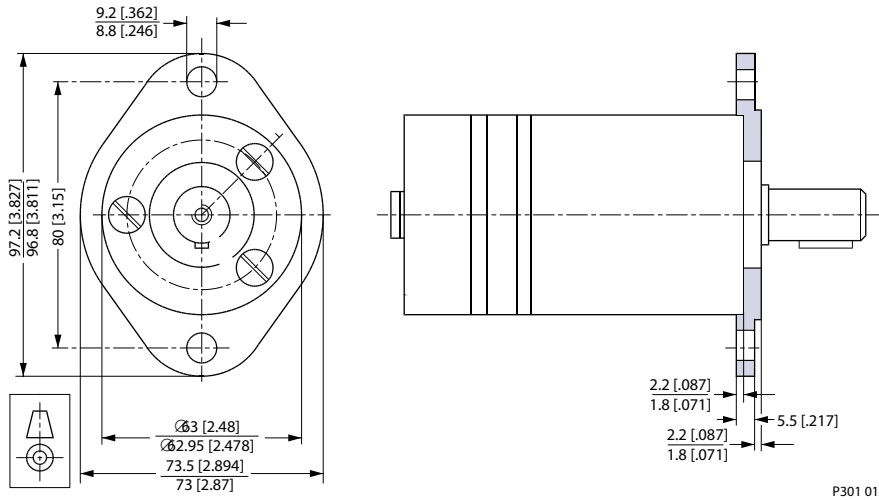

Chapter

5

Hydraulic systems

Topics:

- *Installation of the Orbital Motors*
- *Starting up and running in the hydraulic system*
- *Operation*
- *Maintenance*

Installation of the Orbital Motors

About the design

- To ensure efficient operation all hydraulic components must be installed according to their individual instructions.
- The pump line must include a manometer connection.
- To ensure designed contact and minimise the tension all mounting flanges must be flate.

Hydraulic lines must be fitted correctly to prevent air entrapment.

About the assembly

- Follow the mounting instructions printed on the inside of the cardboard box.
- To prevent contamination, do not dismantle the plastic plugs from the connection ports until the fittings are ready to be assembled.
- Check that there is full face contact between the motor mounting flange and the mating part.
- Do not force the motor into place when tightening the mounting screws.
- Avoid unsuitable sealing material on fittings such as pack twine, teflon and others.
- Use only bonded seals, O-rings, steel washers and the like.
- When tightening the fittings never use a torque higher than the max. tightening torque stated in the instructions.
- Make sure that the cleanliness of the oil used is better than 20/16 (ISO 4406). Always use a filter for oil refilling.

Starting up and running in the hydraulic system

- Through a small-meshed filter fill up the tank with oil to the upper oil level mark.
- Start the drive engine, and if possible, let it work at its lowest speed. If the motor is provided with bleed screws, keep these open until the emerging oil is non-foaming.
- Check that all components are correctly connected (pump following the right direction of rotation etc.).
- In load-sensing systems, also make sure that the signal lines are bled.
- Indications of air in the hydraulic system:
 - oam in the tank
 - jerky movements of motor and cylinder
 - noise
- If so required, refill with oil.
- Connect the system to a separate tank that includes a filter (fineness max. 10 µm) with twice the capacity of the max. oil flow. Let the entire system run without load (no pressure) for about 30 minutes.
- Do not load the system until it is all bled and clean.
- Check the tightness of the system and make sure that its performance is satisfactory.
- Change the oil filter, and if so required, refill with oil.

Operation

- Do not expose the motor to pressures, pressure drops and speeds above the max. values stated in the catalogue.
- Filter the oil to ensure that the contamination level 20/16 (ISO 4406) or better.

Maintenance

- When working with hydraulic systems, the main criteria of operating safety and endurance is careful maintenance.

- Always renew and replace oil, oil filters and air filters according to the instructions given by the respective manufacturers.
- Regularly check the condition of the oil.
- Frequently check system tightness and oil level.

