

Repair Instructions Orbital Motors OMP, OMP C, and OMPW/N Series 7 and 8



OIL SOLUTIONS

PO Box 38

Strathfieldsaye, VIC, 3551

1800 OIL SOL

1800 645 765

sales@oilsolutions.com.au

www.oilsolutions.com.au

"For All Your Hydraulic Needs"

Contents

Chapter 1: Safety Precautions.....	5
Chapter 2: Special Versions and Cost-free Repairs.....	7
Special Versions.....	8
Cost-free Repairs.....	8
OMP Series 7.....	8
OMP Series 8.....	8
Chapter 3: OMP Metric Version, Series 8 with Integrated Spigot Flange.....	9
Exploded view.....	10
Chapter 4: OMP/OMP C Metric Version, Series 7 with Separate Spigot Flange.....	11
Exploded view.....	12
Chapter 5: OMP W and OMPW N Metric Version, Series 7.....	13
Exploded view.....	14
Chapter 6: Spare Part List.....	15
Spare part list.....	16
Tightening Torque.....	25
Chapter 7: Special Tools.....	27
Special tools.....	28
Chapter 8: Dismantling / Cleaning.....	31
Dismantling.....	32
Cleaning.....	33
Chapter 9: Assembly.....	35
Assembly.....	36

Chapter 1

Safety Precautions

Always consider safety precautions before beginning a service procedure. Protect yourself and others from injury. Take the following general precautions whenever servicing a hydraulic system.



Warning:

Unintended machine movement

Unintended movement of the machine or mechanism may cause injury to the technician or bystanders. To protect against unintended movement, secure the machine or disable / disconnect the mechanism while servicing.



Warning:

Flammable cleaning solvents

Some cleaning solvents are flammable. To avoid possible fire, do not use cleaning solvents in an area where a source of ignition may be present.



Warning:

Fluid under pressure

Escaping hydraulic fluid under pressure can have sufficient force to penetrate your skin causing serious injury and/or infection. This fluid may also be hot enough to cause burns. Use caution when dealing with hydraulic fluid under pressure. Relieve pressure in the system before removing hoses, fittings, gauges, or components. Never use your hand or any other body part to check for leaks in a pressurized line. Seek medical attention immediately if you are cut by hydraulic fluid.



Warning:

Personal safety

Protect yourself from injury. Use proper safety equipment, including safety glasses, at all times.

Chapter

2

Special Versions and Cost-free Repairs

Topics:

- *Special Versions*
 - *Cost-free Repairs*
 - *OMP Series 7*
 - *OMP Series 8*
-

Special Versions

The list of spare parts cannot be used when ordering parts for special OMP versions.

In this respect, please contact the sales organisation.

Cost-free Repairs

We would point out that cost-free repairs as mentioned in General Conditions of Sale, are carried out only at service shops authorised by the organization.

OMP Series 7

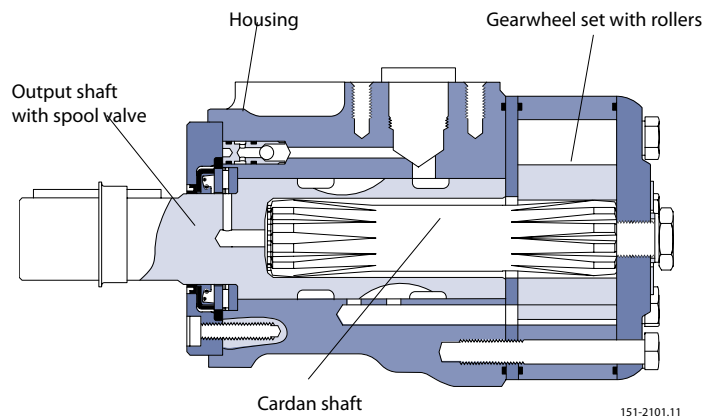

OMP Series 8

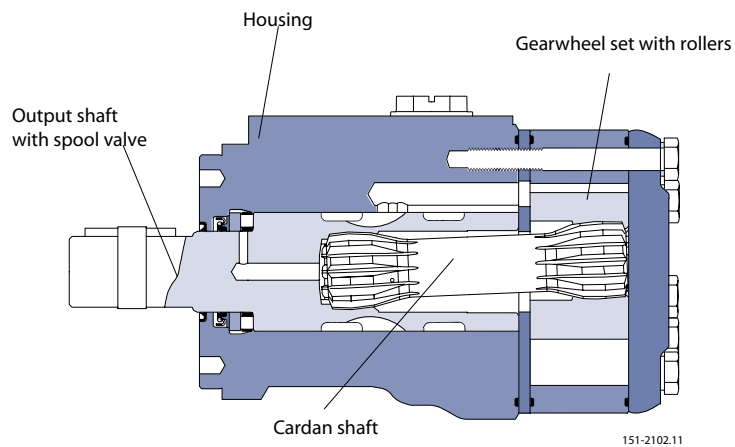

Chapter

3

OMP Metric Version, Series 8 with Integrated Spigot Flange

Topics:

- [Exploded view](#)
-

Exploded view

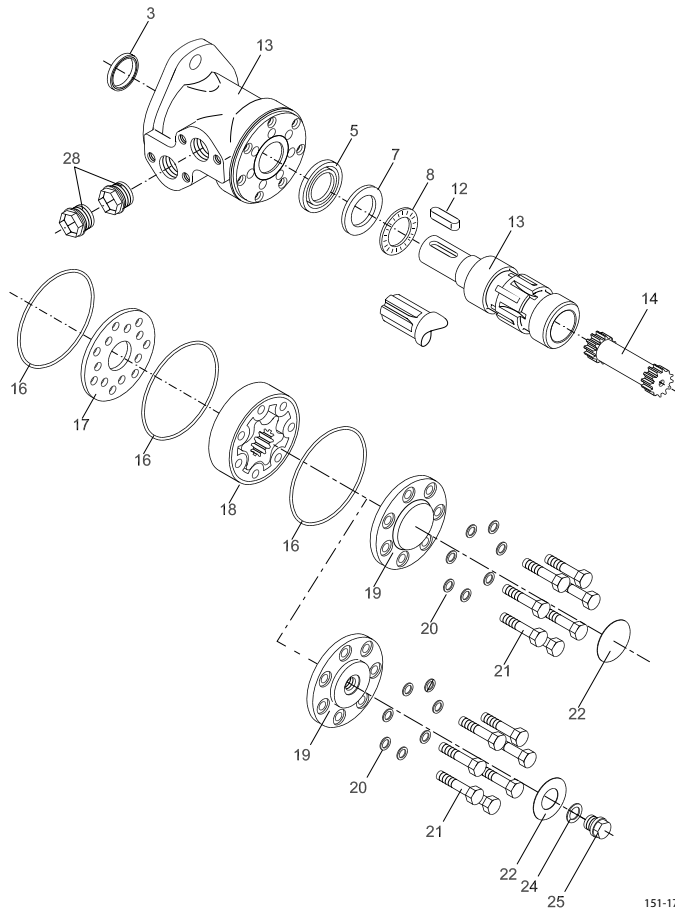

151-1767.11

Chapter

4

OMP/OMP C Metric Version, Series 7 with Separate Spigot Flange

Topics:

- [Exploded view](#)

Exploded view

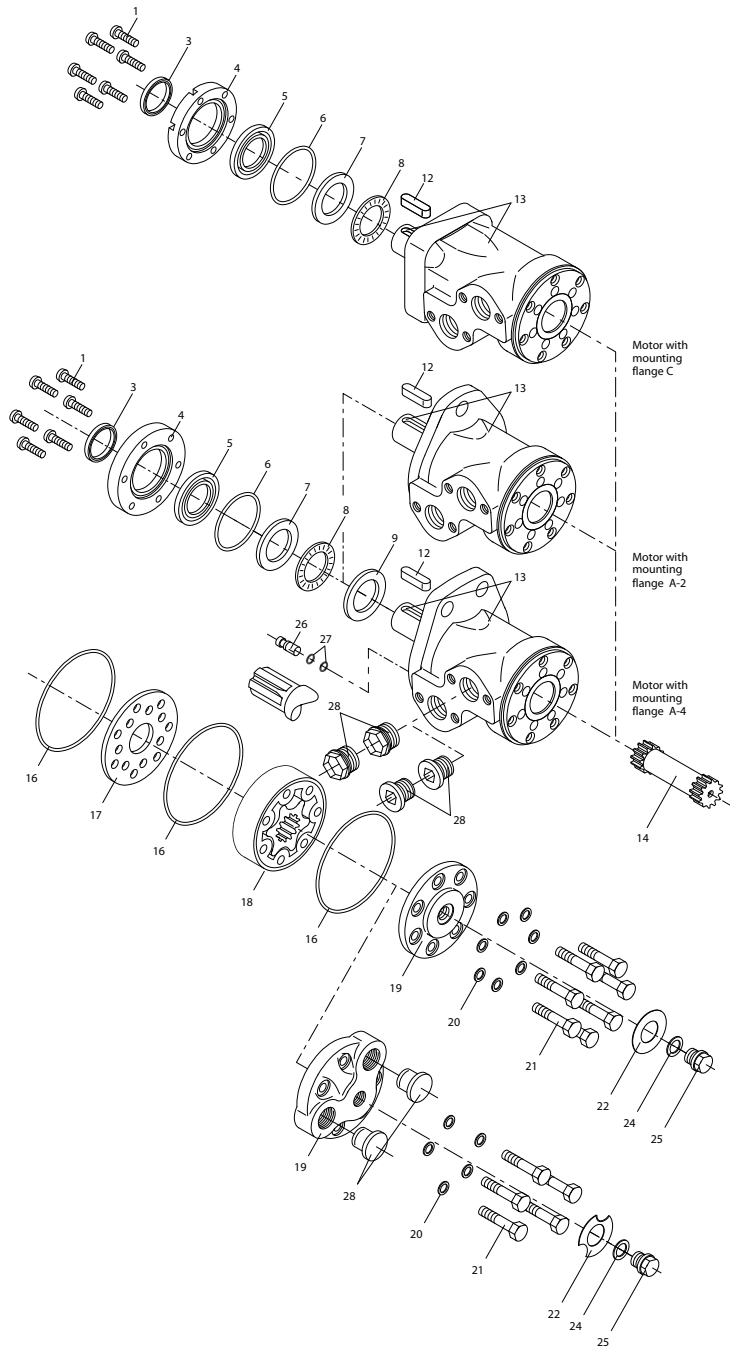

Chapter

5

OMP W and OMPW N Metric Version, Series 7

Topics:

- *Exploded view*
-

Exploded view

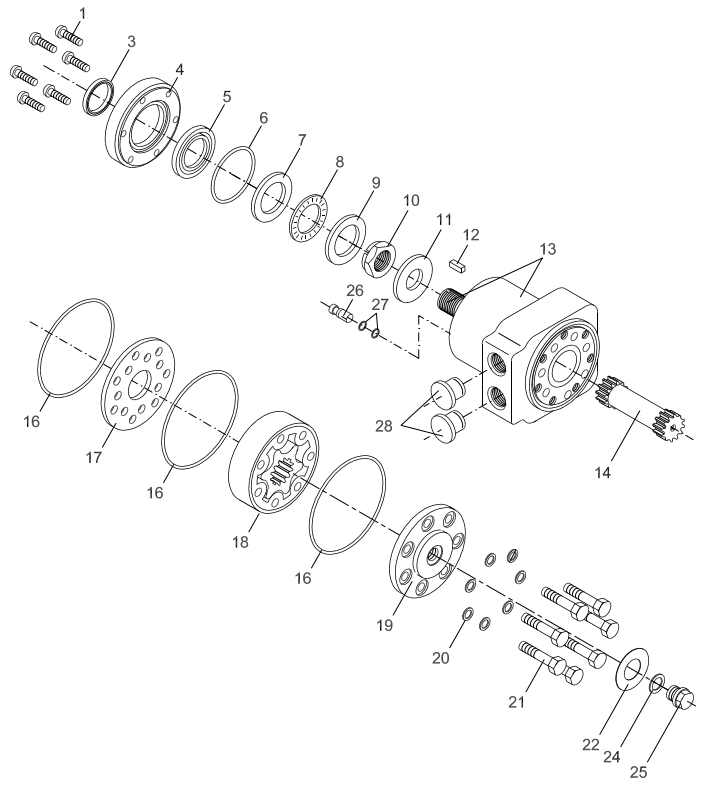

151-1379.10

Chapter

6

Spare Part List

Topics:

- *Spare part list*
 - *Tightening Torque*
-

Spare part list

Item	Spare Part	Dimensions	Number per motor				
			Code no.	Series 8	Series 7 with separate spigot flange		
					OMP Flange A2	OMP Flange A2	OMP C Flange A4
1	Screw	M6: L = 16	681X1989	6	6	6	
		M5: L = 16	681X1961			6	
		M6: L = 16	681X0247		6		
3	Dust seal ring						
	ø25 mm, ø1", 1" spl. shaft (HPS)	35.0 • 27.5 • 2.2 mm	633B0370	1			
	ø28.5 mm tapered shaft	28.56 • 35.0 • 4.0 mm	151-1313	1	1	1	1
	ø25 mm shaft	35.0 • 28.5 • 4.0 mm	633B0010		1		
	ø32 mm shaft	42.0 • 35.0 • 3.5 mm	633B3198		1		
4	Spigot flange						
	ø25 mm, ø1", 1" spl. shaft (HPS)		151-5588	1	1		
	ø25 mm, ø1", 1" spl. shaft		151-5458	1	1		
	ø25 mm shaft		151-5473		1		
	ø25 mm shaft		151-1827			1	
	ø25 mm, ø28.5mm tapered shaft		151-1978				1
	ø32 mm shaft, (HPS)		151-5589		1		
	ø32 mm shaft		151-1734		1		

* Series 8 with integrated spigot flange

Item	Spare Part	Dimensions	Number per motor							
			Code no.	Series 8	Series 7 with separate spigot flange					
					OMP Flange A2	OMP Flange A2	OMP C Flange A2	OMP Flange A4	OMP Flange C	OMP W OMP N
5	Shaft seal									
	ø25 mm, ø1", 1" spl. shaft (HPS)	39.0 • 28.6 • 4.9 mm, HSN	633B03 61	1	1	1				
	ø25 mm, ø1", 1" spl. 28.5 mm tapered shaft	42.0 • 28.6 • 5.5 mm, NBR	633B33 85		1	1	1	1	1	
	ø25 mm, ø1", 1" spl. shaft 28.5 mm tapered shaft	42.0 • 28.6 • 5.5 mm, FPM	633B03 23		1	1	1	1	1	
	ø32 mm shaft, (HPS)	46.0 • 35.0 • 4.6 mm	633B03 63		1	1				
	ø32 mm shaft	48.0 • 35.0 • 5.5 mm	633B32 73		1	1				
6	O-ring									
	ø25 mm, ø1", 1" spl. 28.5 mm tapered shaft	47.2 • 3.5 mm, NBR	633B11 91		1	1	1			1
	ø25 mm	48.0 • 2.0 mm, NBR	633B13 33					1		
	ø32 mm shaft	53.0 • 2.0 mm, NBR	633B15 28			1				
7	Bearing race									
	ø25 mm, ø1", 1" spl. shaft	41.6 • 29.0 • 4.0 mm	110438 24	1						
	ø25 mm, ø1", 1" spl. shaft	47.5 • 29.5 • 3.0 mm	151-16 08		1	1	1	1	1	
	28.5 mm tapered shaft	47.5 • 29.5 • 2.4 mm	151-19 31							1
	ø32 mm shaft	52.0 • 35.0 • 3.5 mm	110459 61			1				

* Series 8 with integrated spigot flange

Item	Spare Part	Dimensions	Number per motor									
			Code no.	Series 8	Series 7 with separate spigot flange							
					OMP Flange A2	OMP Flange A2	OMP C Flange A2	OMP Flange A4	OMP Flange C	OMP W OMP WN		
8	Axial needle bearing											
	ø25 mm, ø1", 1" spl. shaft	42.0 • 28.7 • 4.5 mm	110438	1								
	ø25 mm, ø1", 1" spl. shaft		151-1458		1	1	1	1	1			
	28.5 mm tapered shaft		981X008									1
	ø32 mm shaft		981X3198				1					
9	Bearing race											
	ø28.5 mm tapered shaft	44.5 • 28.6 • 1.6 mm	151-1940									1
	32 mm shaft	52.0 • 35.0 • 3.5 mm	11045961				1					
10	Castellated nut											
	28.5 mm tapered shaft	M20 • 1.5	681X8202									1
11	Washer											
	for 28.5 mm tapered shaft	44.0 • 20.5 • 4.0 mm	684X2530									1
12	Parallel key											
	for ø25 mm shaft	A8 • 7 • 32 mm, DIN6885	682L8035	1	1		1	1	1			
	for ø25 mm shaft	A8 • 7 • 31 mm	682L9007			1						
	for ø1" shaft	¼ • ¼ • 1¼ in, B.S. 46	682L8036	1	1		1	1				
	for ø32 mm shaft	A10 • 8 • 45 mm, DIN6885	682L8019				1					
	for ø28.5 mm tapered shaft	B5 • 5 • 14 mm, DIN6885	682L8016									1
13	Housing + output shaft											

* Series 8 with integrated spigot flange

Item	Spare Part	Dimensions	Number per motor						
			Code no.	Series 8	Series 7 with separate spigot flange				
					OMP Flange A2	OMP Flange A2	OMP C Flange A4	OMP Flange C	OMP W OMP N
14	Cardan shaft								
	OMP 25	L = 73.8 mm	151-26 90	1					
	OMP 25	L = 91.2 mm	151-54 61		1				1
	OMP 32	L = 74.9 mm	151-26 91	1					
	OMP 32	L = 92.3 mm	151-54 60		1				
	OMP 40	L = 76.8 mm	151-26 43	1					
	OMP 40	L = 94.0 mm	151-17 87		1				
	OMP 50	L = 94.0 mm	151-17 87		1		1	1	1
	OMP 50	L = 76.8 mm	110412 37	1		1			
	OMP 60	L = 92.2 mm	110573 73					1	
	OMP 60	L = 78.2 mm	110412 41	1					
	OMP 80	L = 98.0 mm	151-17 88		1		1	1	1
	OMP 80	L = 80.7 mm	110412 39	1		1			
	OMP 100	L = 100.5 mm	151-17 89		1		1	1	1
	OMP 100	L = 83.3 mm	110412 38	1		1			
	OMP 125	L = 100.5 mm	151-17 89		1		1	1	1
	OMP 125	L = 87.1 mm	110412 40	1		1			
	OMP 160	L = 108.5 mm	151-17 90		1		1	1	1
	OMP 160	L = 91.2 mm	110412 42	1		1			
	OMP 200	L = 113.5 mm	110412 36		1		1	1	1
	OMP 200	L = 96.4 mm	110412	1		1			

* Series 8 with integrated spigot flange

Item	Spare Part	Dimensions	Number per motor						
			Code no.	Series 8	Series 7 with separate spigot flange				
					OMP Flange A2	OMP Flange A2	OMP C Flange A2	OMP Flange A4	OMP Flange C
16	O-ring	75.9 • 1.8 mm, NBR	633B1173	3	3	3	3	3	3
17	Distributor plate		151-1713	1	1	1	1	1	1
18	Gear wheel set								
	OMP 25	W = 4.1 mm	151-1180	1	1				1
	OMP 32	W = 5.2 mm	151-1181	1	1				
	OMP 40	W = 6.5 mm	151-1188	1	1				
	OMP 50	W = 6.5 mm	151-1126	1	1	1	1	1	1
	OMP 60	W = 7.9 mm	151-1283	1				1	
	OMP 80	W = 10.4 mm	151-1127	1	1	1	1	1	1
	OMP 100	W = 13.0 mm	151-1128	1	1	1	1	1	1
	OMP 125	W = 16.3 mm	151-1112	1	1	1	1	1	1
	OMP 160	W = 20.8 mm	151-1129	1	1	1	1	1	1
	OMP 200	W = 26.0 mm	151-1185	1	1	1	1	1	1
	OMP 250	W = 32.5 mm	151-1193	1	1	1	1	1	1
	OMP 315	W = 40.9 mm	151-1186	1	1	1	1	1	1
	OMP 400	W = 52.0 mm	151-1187	1	1	1	1	1	1

* Series 8 with integrated spigot flange

Item	Spare Part	Dimensions	Number per motor							
			Code no.	Series 8	Series 7 with separate spigot flange					
					OMP Flange A2	OMP Flange A2	OMP C Flange A2	OMP Flange A4	OMP Flange C	OMP W OMP N
19	End cover									
	Side port without drain		110668 68	1	1		1			
	Side port motor		151-14 59		1	1	1		1	
	End port motor		151-18 32		1			1		
20	Washer									
	Side port motor	15.2 • 8.2 • 1.0 mm	684X0 115	7	7	7	7		7	
	End port motor	15.2 • 8.2 • 1.0 mm	684X0 115		5			5		

* Series 8 with integrated spigot flange

Item	Spare Part	Dimensions	Number per motor								
			Code no.	Series 8	Series 7 with separate spigot flange						
					OMP Flange A2	OMP Flange A2	OMP C Flange A2	OMP Flange A4	OMP Flange C	OMP W OMP WN	
21	Screw										
	Side port motor	M8 • 1.25									
	OMP 25	l = 30 mm	681X0 238	7	7						7
	OMP 32	l = 30 mm	681X0 238	7	7						
	OMP 40	l = 35 mm	681X0 179	7	7						
	OMP 50	l = 35 mm	681X0 179	7	7	7	7				7
	OMP 60	l = 35 mm	681X0 179	7							
	OMP 80	l = 40 mm	681X0 180	7	7	7	7				7
	OMP 100	l = 40 mm	681X0 180	7	7	7	7				7
	OMP 125	l = 45 mm	681X0 181	7	7	7	7				7
	OMP 160	l = 50 mm	681X0 182	7	7	7	7				7
	OMP 200	l = 55 mm	681X0 183	7	7	7	7				7
	OMP 250	l = 60 mm	681X0 184	7	7	7	7				7
	OMP 315	l = 70 mm	681X0 186	7		7	7				
	OMP 400	l = 80 mm	681X0 188	7		7	7				
	End port motor	M8 • 1.25									
	OMP 50	l = 40 mm	681X0 180			5					5
	OMP 80	l = 45 mm	681X0 181			5					5
	OMP 100	l = 45 mm	681X0 181			5					5
	OMP 125	l = 50 mm	681X0 182			5					5
	OMP 160	l = 55 mm	681X0 183			5					5
	OMP 200	l = 60 mm	681X0			5					5

* Series 8 with integrated spigot flange

Item	Spare Part	Dimensions	Number per motor						
			Code no.	Series 8	Series 7 with separate spigot flange				
				OMP Flange A2	OMP Flange A2	OMP C Flange A2	OMP Flange A4	OMP Flange C	OMP W OMP WN
22	Name plate								
	Side port motor-aluminium			1	1	1		1	
	Side port motor-brass			1	1	1			
	End port motor-aluminium			1			1		
24	Washer	17.5 • 13.5 • 1.5 mm	684X2 120	1	1	1	1	1	
25	Drain plug		151-15 24	1	1	1	1	1	
26	Check valve incl. item 27. Only for OMP motors with built-in check valves		151-10 76	2	2	2	2	2	
28	Plug								
	Side port motor-plastic plug		633X0 074	2	2	2		2	
	End port motor-steel plug		631X9 706	2			2		
	End port motor-plastic plug		633X0 074	2			2		
	Spare parts bag for motors with HPS and ø25 mm, ø1", 1" spl.shaft (Series 8)		151-12 86	1					
3	1 pcs. Dust seal	35 • 27.5 • 2.2 mm NBR	633B03 70						
5	1 pcs. shaft seal (series 8)	39 • 28.6 • 4.9 mm HSN	633B03 61						
16	3 pcs. O-ring	75.9 • 1.8 mm NBR	633B11 73						
16	3 pcs. O-ring	90 • 2.0 mm NBR	633B13 01						
20	7 pcs. Washer	11.9 • 8.2 • 1 mm	684X0 115						
24	1 pcs. Washer	17.5 • 13.5 • 1.5 mm	684X2 120						

* Series 8 with integrated spigot flange

Item	Spare Part	Dimensions	Number per motor						
			Code no.	Series 8	Series 7 with separate spigot flange				
					OMP Flange A2	OMP Flange A2	OMP C Flange A2	OMP Flange A4	OMP Flange C
	Spare parts bag for motors with standard shaft seal and ø25 mm, ø1", 1" spl.shaft 28.5 mm tapered shaft		151-1275		1	1	1	1	1
3	1 pcs. Dust seal	35 • 28.5 • 4.0 mm NBR	151-1313						
5	1 pcs. Shaft seal (series 7)	42 • 28.6 • 5.5 mm NBR	633B3385						
6	1 pcs. O-ring	47.2 • 3.5 mm NBR	633B1191						
6	1 pcs. O-ring	48 • 2.0 mm NBR	633B1333						
16	3 pcs. O-ring	75.9 • 1.8 mm NBR	633B1173						
20	7 pcs. Washer	11.9 • 8.2 • 1 mm	684X0115						
24	1 pcs. Washer	17.5 • 13.5 • 1.5 mm	684X2120						
	Spare parts bag for motors ø32 and 35 mm tapered shaft (Series 6/7)		151-1179		1		1		1
3	1 pcs. Dust seal	42 • 35 • 3.5 mm NBR	633B3198						
5	1 pcs. Shaft seal	48 • 3.5 • 5.5 mm NBR	633B3273						
6	1 pcs. O-ring	53 • 2.0 mm NBR	633B1528						
16	3 pcs. O-ring	75.9 • 1.8 mm NBR	633B1173						
20	7 pcs. Washer	11.9 • 8.2 • 1 mm	684X0115						
24	1 pcs. Washer	17.5 • 13.5 • 1.5 mm	684X2120						

NBR: (Buna N, Perbunan)

* Series 8 with integrated spigot flange

** Excl.dust seal ring 633B0010

FPM: Viton (ISO 1629)

HPS: High pressure shaft seal

Tightening Torque

Item	Code number	Torque N•m	Torque [lbf•in]
1	681X1989	5 - 8	[45 - 70]
	681X0247	5 - 8	[45 - 70]
	681X1961	5 - 10	[45 - 88]
10	681X8202	90 - 110	[800 - 975]
21	-	30 - 35	[270 - 315]
25	-	38 - 44	[335 - 390]
28	631X9706	20 - 23	[180 - 200]

Chapter

7

Special Tools

Topics:

- *Special tools*
-

Special tools



F300 083

Figure 1: Main holding tool (horse hole): Code No.: SJ 151-9000-1.



F300 945

Figure 2: Fork. For use when fitting OMP cardan shaft. Code No.: SJ 151-9000-3.

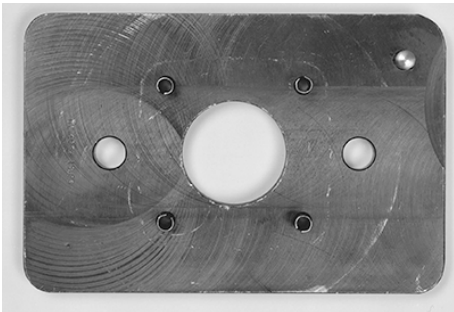

F300 131

Figure 3: SJ 151-9000-12.



F300 129

Holding tool for motor with square mounting flange: Code No.: SJ 151-9000-12.

Holding tool for OMPW N. Code No.: SJ 151-9000-14.

Figure 4: SJ 151-9000-14.

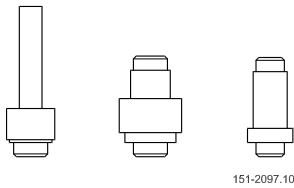

Mandrel: Code No.: SJ 151-9000-7 or SJ 151F9000-7

Figure 5: Mandrel: Code No.: SJ 151-0414

Chapter

8

Dismantling / Cleaning

Topics:

- *Dismantling*
 - *Cleaning*
-

Dismantling

Item	Part to remove	Comments
10	Castellated nut	
11	Washer	
12	Parallel key	
28	Seal plugs	Put the motor in a holding tool, with the output shaft downward. For end port version use 10 mm hexagon socket spanner.
25, 24	Drain plug, washer (if present)	Use a 17 mm spanner socket.
21, 20	Screws, washers	Use a 13 mm spanner socket.
19	End cover	Remove end cover sideways.
18, 16	Gear wheel set O-rings (2 off)	Keep fingers under the gearwheel set to prevent the parts from falling out.
14	Cardan shaft	
Item	Part to remove	Comments
13	Output shaft	<i>Motors with integrated spigot flange:</i> Place the motor housing on the work bench and press the shaft out of the motor housing. Shaft and bearings should normally not be removed from OMPW N. However, if necessary for inspection and cleaning, remove the shaft from the housing by gently tapping the axle journal with a plastic hammer. The front bearing can thus remain in the housing. After this, turn the motor.
1	Screws (6 off)	Use Torx-spanner type T30, 9 mm screwdriver or 4 mm hexagon socket spanner.
4	Spigot flange	
6, 7	O-ring, bearing race	<i>Motors with integrated spigot flange:</i> Remove bearing and bearing race from the motor housing. <i>Motors with separate spigot flange:</i> Use a 2 mm screwdriver
8	Needle bearing	

Item	Part to remove	Comments
5	Shaft seal	<i>Motors with integrated spigot flange:</i>
3	Dust seal	With mandrel and plastic hammer, carefully knock out the shaft seal. <i>Motors with separate spigot flange:</i> Knock out the shaft seal / dust seal with a plastic hammer. Use mandrel SJ 151-9000-7 or SJ 151F9000-7
9	Bearing race	Only OMP/OMPW N with $\varnothing 32$ mm/28.5 mm tapered shaft. Use a 2 mm screwdriver.
26	Check valves (2 off)	<i>Only OMP with check valves.</i> Pull the check valve out with, for example, a ground (shortened) 3.5 mm screw tap.

Cleaning

Cleaning

Clean all parts carefully with low aromatic kerosine.

Inspection and replacement

Check all parts carefully and replace if necessary.

Lubrication

Before assembly, lubricate all parts with hydraulic oil and grease rubber parts with vaseline.

Chapter 9

Assembly

Topics:

- [Assembly](#)
-

Assembly

Item	Part to install	Comments
		Place the motor housing in the holding tool with the flange upwards.
26	Check valves (2 off)	<p><i>Only OMP with check valves</i></p> <p>Grease the check valves (fitted with new O-rings) and fit them in their bores with light blows using plastic hammer.</p>
9	Bearing race	Only OMP/OMPW N with $\varnothing 32$ mm / 28.5 mm tapered shaft.
5	Shaft seal	<p><i>Motors with integrated spigot flange:</i></p> <p>Lubricate the shaft seal on the outside with hydraulic oil. Fit the shaft seal correctly onto mandrel SJ 151-0414 and carefully press the shaft seal into position in the motor housing.</p> <p><i>Motors with separate spigot flange:</i></p> <p>Knock the seal into position in the spigot flange. Check that the seal lies against the cover recess. Use mandrel SJ 151-9000-7 or SJ 151F9000-7</p>
3	Dust seal ring	<p>Place the dust seal ring in the spigot flange and knock it into position with a plastic hammer and appropriate mandrel.</p> <p>SJ 151-9000-7 or SJ 151F9000-7</p>
7, 6	Bearing race O-ring	<p><i>Motors with integrated spigot flange:</i></p> <p>Fit bearing and bearing race onto the shaft and mount together with the shaft.</p> <p><i>Motors with separate spigot flange:</i></p> <p>Grease the O-ring with vaseline and fit the bearing race and O-ring into the spigot flange.</p>
8	Needle bearing	
4	Spigot flange	Turn so that the holes line up.
2	Washer	Only OMPW N
1	Screws (6 off)	<p><i>Tightening torque</i></p> <p>Torx screws M6: 5-8 Nm [45-70 lbf•in]</p> <p>Slotted screws M6: 5-8 N•m [45-70 lbf•in]</p> <p>Hexagon socket screws M5: 5-10 N•m [45-70 lbf•in]</p> <p>Hexagon socket screws M5: 12-15 N•m [45-70 lbf•in]</p> <p>After this, turn the motor.</p>

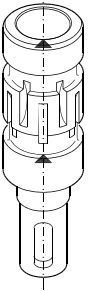
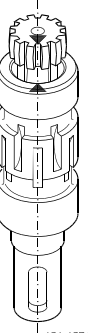
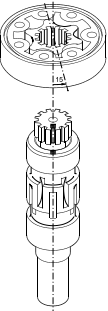
Item	Part to install	Comments
13		<p><i>Grease the journals with hydraulic oil.</i></p> <p>The rear shaft end must be marked before fitted. The mark must be positioned vertically above a commutation slot leading up to the front annular channel.</p> <p>For OMPW N, guide the shaft into the motor housing back with the rear needle bearing fitted on the shaft. Bring the shaft in line with the back of the motor by gently tapping the shaft with a plastic hammer. Check that the shaft rotates easily</p>
<p>Figure 6: Output Shaft</p>		
16	O-ring	Grease the O-ring and put it in the O-ring groove of the housing.
17	Distributor plate	Turn the distributor plate so that the holes line up.
14		<p>Guide the cardan shaft down into the motor housing.</p> <p>Only OMP 25, 32 and 40</p> <p>Place the assembly tool under the upper splines of the cardan shaft.</p> <p>In case of different splines lengths turn the cardan shaft to ensure the long splines end is fitted in the output shaft.</p> <p>Transfer marking from output shaft to cardan shaft.</p>
<p>Figure 7: Cardan shaft</p>		
18, 16		<p>Place the O-rings (greased) in the O-ring grooves of the gearwheel.</p> <p>In gearwheels with non through splines place the gearwheel with the recess in the spline hole facing down towards the housing.</p> <p>Place the gearwheel set on the cardan shaft so that the top of a tooth in the external teeth of the gearwheel is vertically above the mark on the cardan shaft.</p> <p>Turn the gearwheel set counter clockwise until the cardan shaft and the gearwheel start to mesh (15°). Turn the gearwheel rim so that the holes made for the screws line up.</p>
<p>Figure 8: Gearwheel set</p>		
19	End cover	Turn the end cover so that the holes line up.
20, 21	Washer, screws	<p>Use a 13 mm spanner socket</p> <p>Tightening torque: 30 - 35 N•m [265-310 lbf•in].</p>

Item	Part to install	Comments
24, 25	Washer, drain plug	Use a 17 mm spanner socket. Tightening torque: 30 - 60 N•m [270-315 lbf•in].
28	Seal plugs Threaded plug (if present)	End port version: Screw plastic plugs into end ports. Screw in the side port plugs using 10 mm hexagon socket spanner. Tightening torque: 50 - 70 N•m [445-620 lbf•in]. Side port version: Screw in plastic plugs.
12	Parallel key	To be secured with tape or plastic ring
11	Washer	
10	Castellated nut	