



OIL SOLUTIONS

---

**PO Box 38**  
**Strathfieldsaye, VIC, 3551**  
**1800 OIL SOL**  
**1800 645 765**  
**[sales@oilsolutions.com.au](mailto:sales@oilsolutions.com.au)**  
**[www.oilsolutions.com.au](http://www.oilsolutions.com.au)**  
**"For All Your Hydraulic Needs"**

# **User Manual**

## **ATEX instruction for OMR**



# Contents

<b>Chapter 1: Introduction OMR.....</b>	<b>5</b>
General information.....	6
Intended use.....	6
Marking of motors.....	6
T codes and maximum surface temperature for OMR motors.....	8
 <b>Chapter 2: Technical information.....</b>	 <b>11</b>
Product description.....	12
Operating principle for OMR motors.....	12
Technical specification for OMR motors.....	12
Oil types / Operating fluids.....	12
Mineral oils for OMR orbital motors.....	13
Temperature and viscosity.....	13
Ambient temperature for OMR orbital motor.....	13
Oil temperature for OMR orbital motor.....	13
Viscosity.....	13
Filtering.....	14
Painting of the motor.....	14
 <b>Chapter 3: Installation, operation and maintenance.....</b>	 <b>15</b>
Installation.....	16
Assembly of OMR motor to the system.....	16
Hydraulic connections for OMR motors.....	16
Operation.....	17
Pre-start up controls for OMR motors.....	17
Start up.....	18
Maintenance.....	18
Service and repair of OMR motor.....	19
 <b>Chapter 4: Declaration.....</b>	 <b>21</b>



---

# Chapter

# 1

---

## Introduction OMR

---

### Topics:

- [General information](#)
- [Intended use](#)

This documentation applies to the following products:

- Hydraulic orbital motor type OMR

## General information

---

### Purpose of this document

This User Manual has been prepared by the manufacturer in order to provide important information regarding the safe installation, operation and maintenance of ATEX certified motors.

This User Manual is a supplement to existing product instruction as ATEX components are subjected to some limitations compared to standard components. The limitations are described in this ATEX instruction.

It is intended for machine/system manufacturers, fitters and service technicians. Please read this User Manual carefully before you work with and start-up the motor.

This User Manual must lie close to the motor.

### Manufacturer responsibility

The manufacturer declines any responsibility in case of:

- Use of the product not according to safety regulations and legislation valid in the user's country.
- Use of the product in operating conditions not allowed according to the product technical documentation.
- Improper installation: the instructions given in this User Manual are not followed or not properly followed.
- Hydraulic system problems.
- Modification of the product.
- Operations executed by personnel not properly trained or not assigned to such a kind of operations.

### Product safety

The safety of the product depends upon the strict observation of the indications given in this User Manual: in particular, it is necessary to:

- Always operate within allowed product working operating conditions (please refer to the Technical Information of the motor in usage).
- Always perform an accurate ordinary maintenance activity.
- Assign the inspection activity as well as maintenance activity to duly trained personnel.
- Only use original spares.
- Always use the product according to the indications you find in this manual.

## Intended use

---

Hydraulic motors convert hydraulic energy (pressure, oil flow) into mechanical energy (torque and speed). They are designed for mobile and stationary applications.

The motors fulfill the explosion requirements with the Directive 2014/34/EU for the category shown on the name plate.

The OMR motors have the following identifying name plate. The name plate provides essential information and specification for correct and safe use.

This identifying plate has to be maintained so that the data can be clearly read; consequently, a periodic cleaning of the plate is required.

## Marking of motors

The OMR motors are marked for application gaseous and dusty environments according to the below:

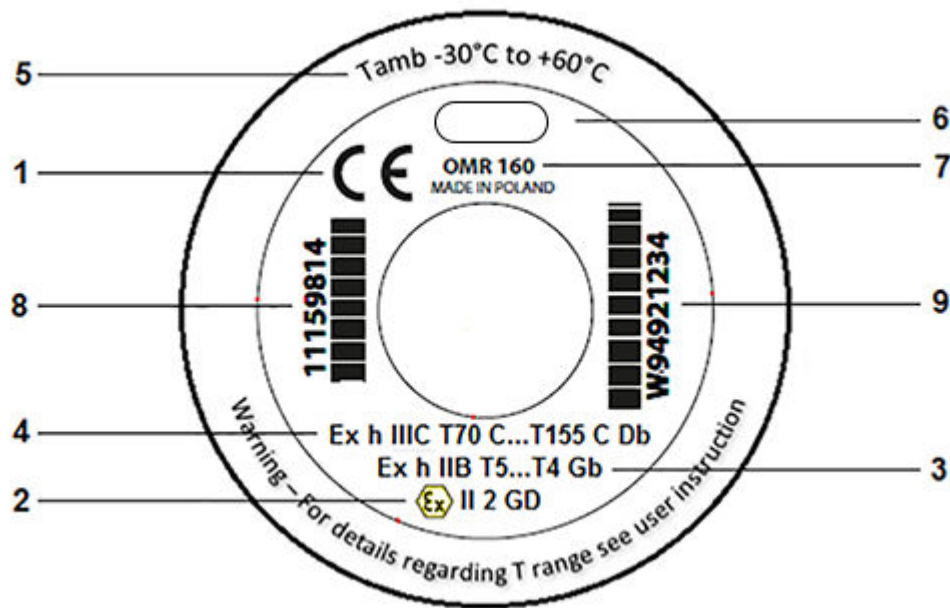

**Figure 1: ATEX label layout**

Key to label image:

1. CE Conformity marking
2. EU marking (per 2014/34/EU) - Directive part

Description	EU Marking
CE conformity marking	CE
Explosion protection marking	
Equipment group	II
Equipment category	2G / 2D

3. EU marking (per EN ISO 80078-36.2016 Standard part)

Description	EU marking	
Protection principle	h	
Explosion protection marking	Ex	
Equipment group	II / III	
Equipment protection level (EPL)	Gb / Db	
T-class	Gas	T5...T4
	Dust	T70°C...T155°C

**Table 1: EPL/Equipment category**

Definition	Level of protection	Typical zone of application	EN ISO		EU	
			EPL	Group	Category	Group
Gas atmosphere	Very high	0	Ga	II	1G	II
	High	1	Gb		2G	
	Enhanced	2	Gc		3G	
Dust atmosphere	Very high	20	Da	III	1D	II
	High	21	Db		2D	
	Enhanced	22	Dc		3D	

4. See item 3
5. Min and max ambient temperature (see *T codes and maximum surface temperature for OMR motors* on page 8)
6. Manufacturer
7. Motor type and displacement
8. Code number
9. Production number, date, and series number

Item 9 example: **W94921234**

<b>W</b>	Manufacturing location (W = Wroclaw)
<b>9</b>	Year 2019
<b>49</b>	Week 49
<b>2</b>	Tuesday (1 = Monday)
<b>1234</b>	Consecutive number

## T codes and maximum surface temperature for OMR motors

### T codes for OMR motors – Gaseous environment (Group II)

**Table 2: OMR motors - fluid and ambient temperature**

Maximum oil temperature	Maximum ambient temperature		
	≤ 20 °C [64 °F]	≤ 40 °C [104 °F]	≤ 60 °C [140 °F]
≤ 20 °C [68 °F]	T5	T5	T5
≤ 40 °C [104 °F]	T5	T5	T4
≤ 60 °C [140 °F]	T5	T4	T4
≤ 80 °C [176 °F]	T4	T4	T4

**Table 3: Classification of maximum surface temperatures for Group II equipment:**

Temperature class	Maximum surface temperature	
	°C	[°F]
T4	135	[275]
T5	100	[212]

**Note:**

For Group II with T4 classification it is acceptable that small surface areas (total areas  $\geq 20 \text{ mm}^2$  and  $\leq 1000 \text{ mm}^2$ ) can have surface temperature up to 200 °C.

For T5 classification it is acceptable that small surface areas (total areas  $\leq 1000 \text{ mm}^2$ ) can have surface temperature up to 150 °C.

**Maximum surface temperature – Dusty environment (Group III)****Table 4: OMR motors - Maximum surface temperature**

Maximum oil temperature	Maximum ambient temperature		
	$\leq 20 \text{ °C [68 °F]}$	$\leq 40 \text{ °C [104 °F]}$	$\leq 60 \text{ °C [140 °F]}$
$\leq 20 \text{ °C [68 °F]}$	70	90	110
$\leq 40 \text{ °C [104 °F]}$	85	105	125
$\leq 60 \text{ °C [140 °F]}$	100	120	140
$\leq 80 \text{ °C [176 °F]}$	115	135	155

**Note:** Above maximum surface temperature is without any deposited dust on the motors. The possible insulation effect of a dust layer on the surface temperature has to be taken into account by the safety margin to the minimum ignition temperature of the dust concerned. Up to 5 mm [1.97 in] layer thickness the safety margin is 75 °C [167 °F]. For further information please see IEC 60079-14.



**Warning:** The above operating temperatures (ambient and oil) of the motor must be guaranteed by the end user.



**Warning:** It is compulsory to use oils whose inflammable degree is at least 50K above the maximum surface temperature of the motor. See also *Oil types / Operating fluids* on page 12.



---

# Chapter

# 2

---

## Technical information

---

### Topics:

- *Product description*
- *Technical specification for OMR motors*
- *Oil types / Operating fluids*
- *Temperature and viscosity*
- *Filtering*
- *Painting of the motor*

## Product description

---

### Operating principle for OMR motors

Hydraulic orbital motors convert hydraulic energy (pressure, oil flow) into mechanical energy (torque and speed). Orbital motors are of fixed displacement high-torque design. For a given oil flow and given pressure the displacement (size of motor) determines the speed and torque. For a given displacement (size of motor) the speed is determined by the oil flow rate and the torque is determined by the pressure differential.

The operating principle of the motor is based on an internal gear design, consisting of a fixed external gear reaching against an internal gear through which the output torque and speed are transmitted. The distributor valve in the OMR motor is of the spool valve design which is driven synchronously by the internal gear through a cardan shaft ensuring that the individual chambers of the motor are filled and emptied precisely - without losses.

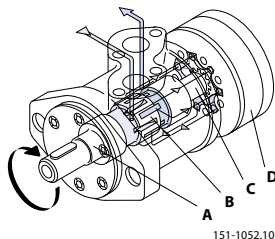

- A: Output shaft
- B: Spool valve
- C: Cardan shaft
- D: Gearwheel set

All parts included in the motors are designed to provide long service life, i.e. long service life with constantly high efficiency and minimum of service required.

### Technical specification for OMR motors

---

All necessary design information for instance maximum pressure rating, maximum flow, maximum radial load etc. is provided in the Technical Information document.

The rated data published in the Technical Information are based on the use of premium mineral based hydraulic oil with a viscosity of 35 mm<sup>2</sup>/s.

### Oil types / Operating fluids

---

In a hydraulic system the most important task of the oil is to transfer energy. At the same time the oil must lubricate moving parts in hydraulic components, protect them from corrosion, and transport dirt particles and heat out of the system. To ensure that hydraulic components operate without problems and have long operating life it is therefore vital to select the correct oil type with the necessary additives.

Ratings and performance data are based on operating with hydraulic fluids containing oxidation, rust and foam inhibitors. These fluids must possess good thermal and hydrolytic stability to prevent wear, erosion and corrosion of motor components.

## Mineral oils for OMR orbital motors

For systems containing hydraulic motor mineral hydraulic oil with anti-wear additives, type HLP [DIN 51524] or HM (ISO 11158) **must be used**.

Mineral oils without anti-wear additives or engine oils can also be used, provided operating conditions are suitable.



**Warning:** It is compulsory to use oils whose inflammable degree is at least 50K above the maximum surface temperature of the motor. Maximum surface temperature for Group II and III can be found under: [T codes and maximum surface temperature for OMR motors](#) on page 8.

Mixing oils of different brands or different oils of the same brand may lead to the formation of sediment and sludge. Consequently a rapid, irreversible deterioration of the system is induced.

## Temperature and viscosity

---

### Ambient temperature for OMR orbital motor

Maximum ambient temperature depends on the requested ATEX class needed – please see [T codes and maximum surface temperature for OMR motors](#) on page 8.

In general the ambient temperature should be between -30 °C [-22 °F] and +60 °C [+140 °F].

### Oil temperature for OMR orbital motor

Max oil temperature depends on the requested ATEX class needed – please see [T codes and maximum surface temperature for OMR motors](#) on page 8.

Under normal operating conditions it is recommended to keep the temperature in the range of 30 °C [86 °F] to 60 °C [140 °F].

Fluid temperature affects the viscosity of the fluid and resulting lubricity and film thickness. High temperatures can also limit seal life, at most nonmetallic materials are adversely affected by use at elevated temperatures.

Fluids may break down or oxidize at high temperature, reducing their lubricity and resulting in reduced life of the unit. Oil life is greatly reduced if its temperature exceeds +60 °C [+140 °F]. As a general rule, oil life is halved for each 8 °C [46 °F] its temperature exceeds +60 °C [+140 °F].

### Viscosity

Maintain fluid viscosity within the recommended range for maximum efficiency and bearing life. Minimum viscosity should only occur during brief occasions of maximum ambient temperature and severe duty cycle operation.

Maximum viscosity should only occur at cold start. Limit speeds until the system warms up.

**Table 5: Fluid viscosity limits**

Conditions	mm <sup>2</sup> /s (cSt)	SUS
Minimum	12	66
Continuous	20 - 80	98 - 370
Maximum	1500	6950

We recommend the use of an oil type having a viscosity of 35 mm<sup>2</sup>/s at the actual operating temperature.

## Filtering

---

It is necessary to keep the level of oil contamination at an acceptable level to ensure problem-free operation. The recommended maximum level of contamination in systems in the hydraulic motor is 22/20/16 (ISO 4406-1999).

## Painting of the motor

---



**Warning:** ATEX certified motors are without painting. In case of additional painting of the motor please make sure that the thickness is in accordance with the relevant standards.

---

# Chapter

# 3

---

## Installation, operation and maintenance

---

### Topics:

- *Installation*
- *Operation*
- *Maintenance*

This section is intended for personnel assigned to install the motor on the machine or system for which the unit has been purchased. Therefore the importance of this section is emphasized since the optimum operation of group machine/system – motor is the consequence of correct assembly of the parts; the correct installation will limit the sources of danger for people working near to the structure.

## Installation

---

### Assembly of OMR motor to the system

When assembling the motor in the machine/system it is the builder's responsibility that the parts used conform to the ATEX directive and that the components are assembled and running according to the operational data/design found in product data sheets and instructions.

Only use the motor as required by the explosion protection shown on the name plate.

Always ensure that the following is maintained:

- The supporting frame, chassis, or structure of equipment containing the motor shall be constructed of electrically conducting material and shall be so arranged as to provide a leakage path to earth (ground) for any static electricity which occurs on the motor.
- It is compulsory to use oils whose inflammable degree is at least 50K above the maximum surface temperature of the motor. Maximum surface temperature for Group II and III can be found under *T codes and maximum surface temperature for OMR motors* on page 8.
- Make sure that all type of accessory installed on the motor are ATEX specified and have been installed in accordance with ATEX requirements.
- There are no creeping metal elements external to the motor.
- There are no plastic parts that might accumulate electrostatic; or they are shielded.
- The maximum permissible oil and ambient temperature is monitored and not exceeded for the category and temperature class of the associated zone.
- For installation in zones 21 and 22 the user has to adopt a scheduled periodic clearing plan of the motor surface and recesses to prevent more than 5 mm thickness of dust deposits.

Manufacture the assembly flange on the machine/system where the motor has to be installed: the relevant surface has to be perfectly smooth, completely de-greased and non-deforming.

It is necessary to verify the perfect alignment between the motor output shaft and the counter part – the fitment between motor shaft and application's driven shaft must be executed so that no radial or axial pre-load is generated – these extra loads reduce the bearings expected lifetime.

### Hydraulic connections for OMR motors

#### Main inlet hoses connections (Y)

The motor has two ports on the valve housing which may be both inlet or outlet ports depending on the application.

#### Drain line connection (X)

The drain line relieves the pressure on the shaft seal to tank. The tank pressure must be less than or equal to the max. permissible pressure on the shaft seal graph shown in the Technical Information document.

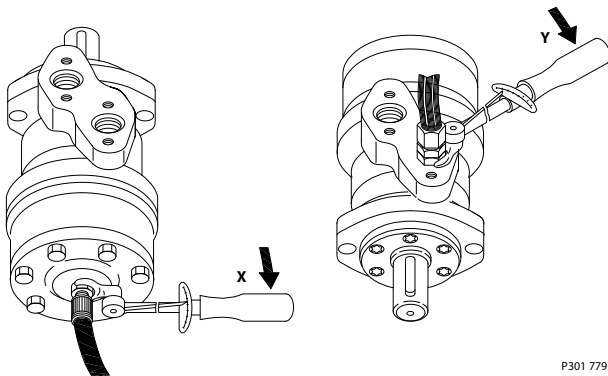

P301 779

The following main rules apply to drain lines fitted to hydraulic motors:

- We recommend a drain line when the maximum pressure on the shaft seal is exceeded, i.e. the life of the shaft seal can otherwise be significantly reduced.
- We always recommend a drain line when
  - A short motor (bearing less motor) is built together with e.g. a gear.
  - The motor is used in hydrostatic transmissions that do not have a separate flushing valve.

### Tightening torque

The recommended tightening torque for the hoses are shown in below table.

**Table 6: Maximum tightening torque**

Screwed connection	G 1/4	G 1/2
- with steel washer	40 N•m [350 lbf•in]	130 N•m [1,150 lbf•in]
- with cutting edge	40 N•m [350 lbf•in]	130 N•m [1,150 lbf•in]

## Operation

The purpose of this section is to indicate the necessary procedures to perform the motor start up.

### Pre-start up controls for OMR motors

Before performing the first motor start up, the following points have to be checked.

Hydraulic components must be installed in accordance with their individual instruction.

1. To avoid contamination, plastic plugs in connection ports must not be removed until just before connections are made.
2. Make sure the motor hydraulic connections allow the motor to rotate in the desired direction. For motors with standard direction of rotation:

Clockwise rotation (viewed facing the output shaft) with inlet pressure in the front port.

Counter-clockwise rotation (viewed facing the output shaft) with inlet pressure in the rear port.

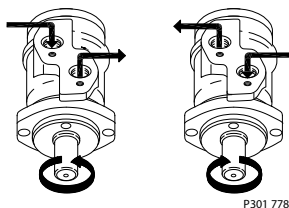

P301 778

**Note:** Generic illustration shown.

3. Select the hydraulic fluid as specified in Oil types / Operating fluids.
4. Ensure full contact between motor mounting flange and connecting part.  
**Note:** Avoid pressing the motor into place by tightening the fixing bolts. Avoid unsuitable seal materials, for example, twine and Teflon, on threaded unions. Use only the seals supplied, such as O-rings, steel washers.
5. Make sure that all couplings are completely tightened to prevent leakage.  
Do not use more torque than the maximum values given in the instructions.
6. Check to make sure the purity of the oil is greater than 22/20/16 (ISO 4406-1999) and always use a filter when replenishing the system.



**Warning:** The motor must be filled with fluid prior to any load applications.

## Start up

During and immediately after the motor start up, any hydraulic system must be closely and frequently checked.

1. To assure best motor performance, run the motor for approximately one hour at 30% of rated pressure and speed before running at full load.  
When running make sure the motor and oil temperature and noise level are sufficiently low. High temperature or noise level might be symptoms of unforeseen operation conditions that have to be analyzed and cleared.
2. Check for system leakage and make sure the system is operating satisfactorily.
3. To ensure that the contamination in the hydraulic system does not damage the motor; the following procedure is recommended after a brief period in operation:
  - a) After a brief period in operation, have a hydraulic fluid specimen analyzed for the required cleanliness level.
  - b) Replace oil filter or change the hydraulic fluid if the required cleanliness level is not reached.

## During operation

The product is a component which requires no settings or changes during operation. The machine/system manufacturer is responsible for the proper project planning of the hydraulic system and its control.

It is recommended to:

- Regularly verify that the temperature of the ambient and the operating oil are those initially determined.
- Do not subject the motor to pressure, pressure drop or speeds exceeding the maximum values stated in the appropriated catalogues.
- Filter the oil to maintain the grade of contamination at 22/20/16 (ISO 4406-1999) or better.

## Maintenance

---



### Warning:

If maintenance has to be performed in an explosive and hazardous atmosphere, an anti-sparking safety tool must be used.

- With hydraulic systems the main criterion for reliability and operating life is very thorough regularly maintenance.
- Regularly check the system for presence of leakage and the oil level.
- During system's function, it is necessary regularly to verify that the temperature of the ambient and the operating oil are those initially determined.
- Replenish and change the oil, the oil and air filters as stated in the respective instructions.
- Regularly check the condition of the oil – viscosity, oxidation, filtration level etc.

**Viscosity**                      Verify that the viscosity level is within the recommended values as indicated in .

**Oxidation**                     Mineral oil gets oxidized proportional to the usage degree and operating temperature. The oxidation of oil is evident because of its change of color, bad smell, acidity increase and

because of the generation of sludge inside the tank. In case symptoms of this kind are detected, the system oil must be immediately changed.

**Water presence** The presence of water inside oil can be determined by taking oil samples from the bed of the oil tank: oil floats on water, if present, water tends to stay on the tank's bed. If its presence is determined, water must be regularly purged. Presence of water in the hydraulic system can severely damage the motor.

**Degree of contamination** A high degree of contamination of the operating oil causes a severe wear of all hydraulic components: for this reason, the cause of the contamination must be identified and eliminated. In order to avoid mixing of different oils, when replacing the operating fluid. It is necessary to empty all the machinery and pipes, clean them carefully and clean the tank.

- For installation in zones 21 and 22 the user has to adopt a scheduled periodic clearing plan of the motor surfaces and recesses to prevent more than 5mm thickness of dust deposits.

## Service and repair of OMR motor

In case a service or repair intervention on the motor is required, it must be performed according to the information shown in below mentioned Repair Instructions.

The Repair Instruction includes the spare part list and information about how dismantling and assembling of the motor is done properly.

**Note:** Only Authorized Service Centers may perform repairs specified in the Repair Instructions.

- *Orbital Motor OMR Series 5 and 6 motors Repair Instructions*

### Safety precautions

Always consider safety precautions before beginning a service procedure. Protect yourself and others from injury. Take the following general precautions whenever servicing a hydraulic system.

### Tools



**Warning:** It is compulsory to use anti sparking safety tools in case the service/repair activity has to be performed in explosive hazardous atmosphere.

### Unintended machine movement



**Warning:** Unintended movement of the machine or mechanism may cause injury to the technician or bystanders. To protect against unintended movement, secure the machine or disable/disconnect the mechanism while servicing. Follow the manufacturers instructions for securing the machine.

### Personal safety



**Warning:** Protect yourself from injury. Use proper safety equipment, including safety glasses, at all times.

### Flammable cleaning solvents



**Warning:** Some cleaning solvents are flammable. To avoid possible fire, do not use cleaning solvents in an area where a source of ignition may be present.

### Fluid under pressure



**Warning:** Escaping hydraulic fluid under pressure can have sufficient force to penetrate your skin causing serious injury and/or infection. This fluid may also be hot enough to cause burns. Use caution when dealing with hydraulic fluid under pressure. Relieve pressure in the system before removing hoses, fittings, gauges, or components. Never use your hand or any other body part to check for leaks in a pressurized line. Seek medical attention immediately if you are cut by hydraulic fluid.



---

# Chapter

# 4

---

## Declaration

---

| EU Declaration of Conformity to be added by White.

