



OIL SOLUTIONS

PO Box 38
Strathfieldsaye, VIC, 3551
1800 OIL SOL
1800 645 765
sales@oilsolutions.com.au
www.oilsolutions.com.au
"For All Your Hydraulic Needs"

Technical Information

OMSW with brake nose Orbital Motors

Contents

Chapter 1: Data survey.....	5
Speed, torque and output.....	6
Chapter 2: Versions.....	7
Chapter 3: Code numbers.....	9
Chapter 4: Technical data.....	11
Technical data for OMSW.....	12
Max. permissible shaft seal pressure.....	13
Pressure drop in motor.....	14
Oil flow in drain line.....	14
Direction of shaft rotation.....	15
Permissible shaft load for OMSW.....	15
Function diagrams.....	16
Shaft version.....	16
Port thread versions.....	17
Chapter 5: Dimensions.....	19
Chapter 6: Weight of motors.....	25

Chapter

1

Data survey

Topics:

- *Speed, torque and output*
-

Speed, torque and output

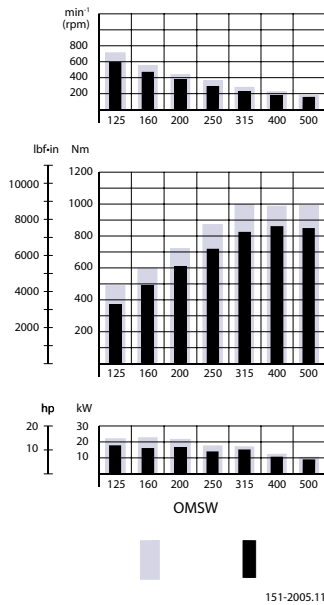

[light] Intermittent values

[dark] Continuous values

Figure 1: Max. speed / Max. torque / Max. output

The bar diagrams above are useful for a quick selection of relevant motor size for the application. The final motor size can be determined by using the function diagram for each motor size.

- OMSW can be found here: [Function diagrams](#) on page 16.

The function diagrams are based on actual tests on a representative number of motors from our production. The diagrams apply to a return pressure between 5 and 10 bar [75 and 150 psi] when using mineral based hydraulic oil with a viscosity of 35 mm²/s [165 SUS] and a temperature of 50°C [120°F]. For further explanation concerning how to read and use the function diagrams, please consult the paragraph "Selection of motor size" in the technical information "General" BC152886483554.

Chapter 2

Versions

OMSW version

Mounting flange	Spigot diameter (front/rear end)	Bolt circle diameter (BC)	Shaft	Port size	End view	Ursion	Side port	End port	Staircase	Din	Check valve	Main type designation
Wheel	Ø5.0 in / Ø5.0 in	Ø 5.8 in	Tap. 1 1/4"	7/8 - 14 UNF	X	X	X	N	Y	OM	SW	
						X	X	X	Y	No	OM	EW
					X		X	X	N	Y	OM	SW
					X		X	X	Y	N	OM	SW

Note: Motors are painted black

Features available (options)

Shaft options:

- 1 3/8" shaft
- Side port G 1/2
- End port G 1/2

High pressure shaft seal

Chapter

3

Code numbers

Table 1: OMSW code numbers

	Displacement						
Code Numbers	125	160	200	250	315	400	500
151F	2502	2503	2504	2505	2506	2507	2508
151F	2512	2513	2514	2515	2516	2517	2518
151F	2522	2523	2524	2525	2526	2527	2528
151F	2532	2533	2534	2535	2536	2537	2538

Ordering

Add the four digit prefix “151F” to the four digit numbers from the chart for complete code number.

Example:

151F2514 for an OMSW 200 as sideport version and with drain connection

Note:

Orders will not be accepted without the four digit prefix.

Chapter

4

Technical data

Topics:

- *Technical data for OMSW*
- *Max. permissible shaft seal pressure*
- *Pressure drop in motor*
- *Oil flow in drain line*
- *Direction of shaft rotation*
- *Permissible shaft load for OMSW*
- *Function diagrams*
- *Shaft version*
- *Port thread versions*

Technical data for OMSW

Type			OMS W	OMS W	OMS W	OMS W	OMS W	OMS W	OMS W
Motor size			125	160	200	250	315	400	500
Geometric displacement	cm ³		125.7	159.7	200.0	250.0	314.9	393.0	488.0
	[in ³]		[7.67]	[9.75]	[12.20]	[15.26]	[19.22]	[23.98]	[29.78]
Maximum speed	min ⁻¹	cont.	600	470	375	300	240	190	155
	[rpm]	int.	720	560	450	360	285	230	185
Maximum torque	N•m	cont.	375	490	610	720	825	865	850
			[3320]	[4340]	[5400]	[6370]	[7300]	[7660]	[7520]
	[lbf•in]	int. ¹⁾	490	600	720	870	1000	990	990
			[4340]	[5310]	[6370]	[7700]	[8850]	[8760]	[8760]
Maximum output	kW	cont.	18.0	16.5	16.5	14.5	15.0	11.0	9.0
	[hp]		[24.1]	[22.1]	[22.1]	[19.4]	[20.1]	[14.8]	[12.1]
		int. ¹⁾	22.5	22.5	23.0	18.0	17.0	12.5	10.5
			[30.2]	[30.2]	[30.8]	[24.1]	[22.8]	[16.8]	[14.1]
Maximum pressure drop	bar	cont.	210	210	210	200	200	160	120
			[3050]	[3050]	[3050]	[2900]	[2900]	[2320]	[1740]
	[psi]	int. ¹⁾	275	260	250	250	240	190	140
Peak		295	280	270	270	260	210	160	
			[4280]	[4060]	[3920]	[3920]	[3770]	[3050]	[2320]
Maximum oil flow	l/min	cont.	75	75	75	75	75	75	75
	[US gal/min]		[19.8]	[19.8]	[19.8]	[19.8]	[19.8]	[19.8]	[19.8]
		int. ¹⁾	90	90	90	90	90	90	90
			[23.8]	[23.8]	[23.8]	[23.8]	[23.8]	[23.8]	[23.8]
Maximum starting pressure with unloaded shaft	bar		10	8	8	8	8	8	8
	[psi]		[145]	[115]	[115]	[115]	[115]	[115]	[115]

¹⁾ Intermittent operation: the permissible values may occur for max. 10% of every minute.

²⁾ Peak load: the permissible values may occur for maximum 1% of every minute.

Type		OMS W	OMS W	OMS W	OMS W	OMS W	OMS W	OMS W	
Motor size		125	160	200	250	315	400	500	
Minimum starting torque	at maximum press drop cont.	290	370	470	560	710	710	660	
	N•m [lbf•in]	[2570]	[3270]	[4160]	[4960]	[6280]	[6280]	[5840]	
	at maximum press drop int. ¹⁾	380	460	560	700	850	840	770	
	N•m [lbf•in]	[3360]	[4070]	[4960]	[6200]	[7520]	[7430]	[6820]	
Type		Max inlet pressure			Max return pressure with drain line				
OMSW	bar	cont.	230			140			
	[psi]		[3340]			[2030]			
	bar	int. ¹⁾	290			175			
	[psi]		[4280]			[2540]			
	bar	peak	300			210			
	[psi]		[4350]			[3050]			

Note: For max. permissible combination of flow and pressure, see function diagram for actual motor.

Max. permissible shaft seal pressure

OMSW with check valves

The pressure on the shaft seal never exceeds pressure in the return line

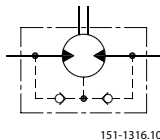

OMSW with drain connection

Use of the drain connection:

The shaft seal pressure equals the pressure in the drain line.

Without use of the drain connection:

The shaft seal pressure equals the average of input pressure and return pressure.

¹⁾ Intermittent operation: the permissible values may occur for max. 10% of every minute.

²⁾ Peak load: the permissible values may occur for max. 1% of every minute.

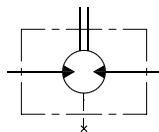

151-1855.10

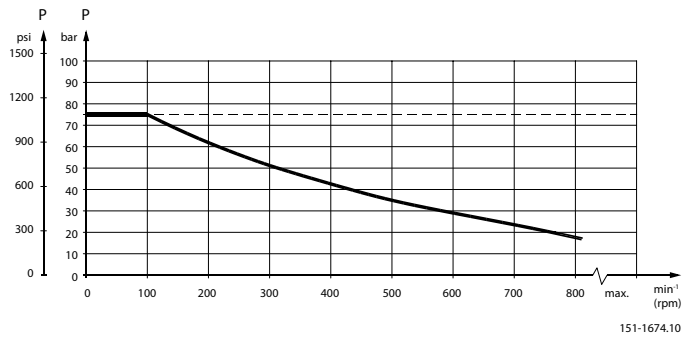

151-1674.10

[dotted line] Intermittent operation: the permissible values may occur for max. 10% of every minute

[solid line] Continuous operation

Figure 2: Max. pressure on shaft seal

Pressure drop in motor

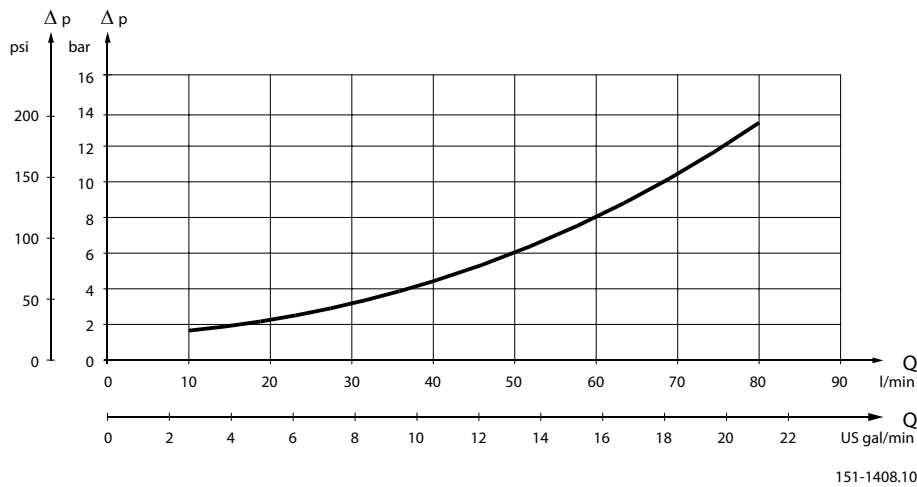

151-1408.10

Figure 3: The curve applies to an unloaded motor shaft and an oil viscosity of 35 mm²/s [165 SUS]

Oil flow in drain line

The table below shows the max. oil flow in the drain line at a return pressure less than 5-10 bar [75-150 psi].

Pressure Viscosity Oil flow in drop drain line bar mm²/s l/min [psi] [SUS] [US gal/min]

Pressure drop bar [psi]	Viscosity mm ² /s [SUS]	Oil flow in drain line l/min [US gal/min]
140 [2030]	20 [100]	1.5 [0.40]
	35 [165]	1.0 [0.26]
210 [3050]	20 [100]	3.0 [0.79]
	35 [165]	2.0 [0.53]

Direction of shaft rotation

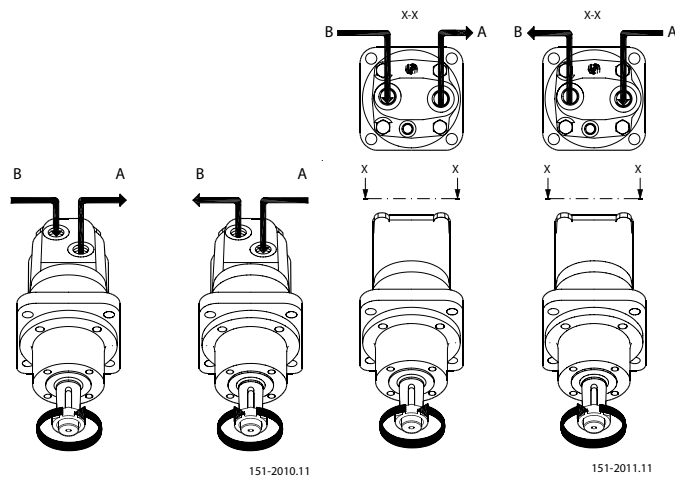

Permissible shaft load for OMSW

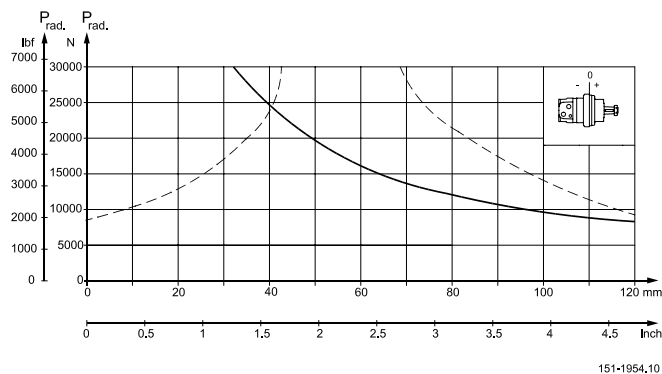

Figure 4: Mounting flange: Wheel / Shaft: All shaft types

Permissible radial shaft load

The output shaft runs in tapered roller bearings that permit high axial and radial forces.

The permissible radial load on the shaft is shown for an axial load of 0 N as a function of the distance from the mounting flange to the point of load application.

The curve is based on B₁₀ Bearing life (2000 hours or 12 000 000 shaft revolutions at 100 min⁻¹) at rated output torque, when mineral-based hydraulic oil with a sufficient content of anti-wear additives, is used.

Function diagrams

Explanation of function diagram use, basis and conditions can be found on page 5.

[blue] Continuous range

[pink] Intermittent range (max. 10% operation every minute)

Note:

Intermittent pressure drop and oil flow must not occur simultaneously.

Explanation of function diagram use, basis and conditions can be found on page 5.

[blue] Continuous range

[pink] Intermittent range (max. 10% operation every minute)

Note:

Intermittent pressure drop and oil flow must not occur simultaneously.

Explanation of function diagram use, basis and conditions can be found on page 5.

[blue] Continuous range

[pink] Intermittent range (max. 10% operation every minute)

Note:

Intermittent pressure drop and oil flow must not occur simultaneously.

Explanation of function diagram use, basis and conditions can be found on page 5.

[blue] Continuous range

[pink] Intermittent range (max. 10% operation every minute)

Note:

Intermittent pressure drop and oil flow must not occur simultaneously.

Shaft version

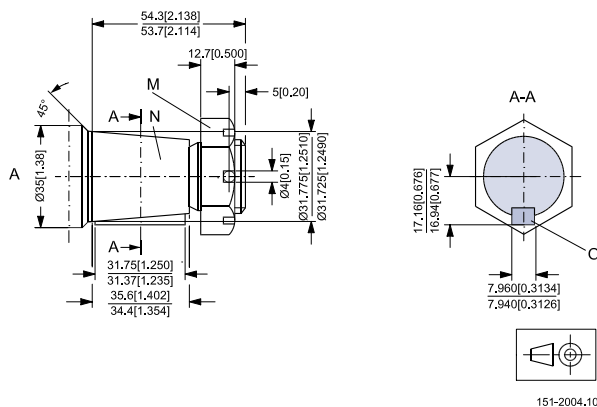

A: Tapered 1 1/4 in shaft

N: Cone 1:8 SAE J501

M: 1 - 20 UNEF across flats 1 7/16 in Tightening torque: 200 ± 10 Nm [1770 ± 85 lbf-in]

O: Parallel key 5/16 x 5/16 x 1 1/4 SAE

Port thread versions

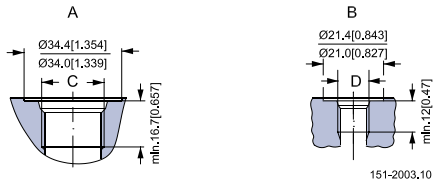

A: UNF main port

C: 7/8 - 14 UNF o-ring boss port

B: UNF drain port 7/16 - 20 UNF o-ring boss port

Chapter 5

Dimensions

OMSW with side port and check valve

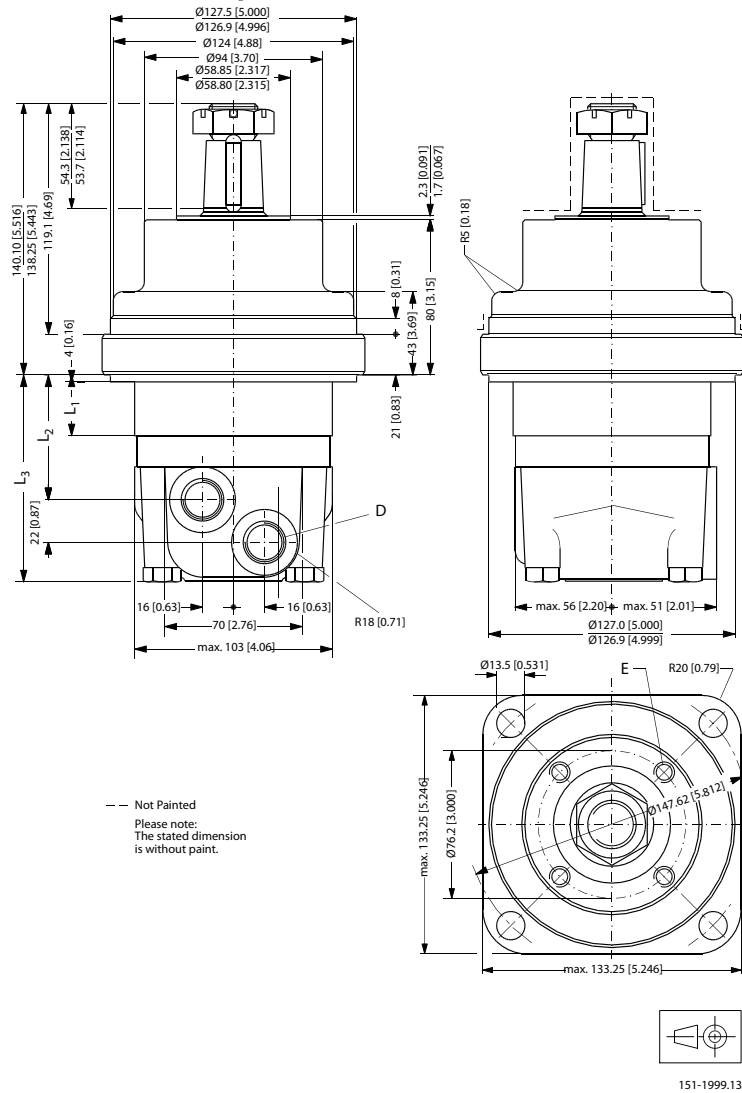

D: 7/8 - 14 UNF; 16.76 mm [0.66 in] deep

E: Thread for external brake 4 x 5/16 - 18 UNF; 13 mm [0.51 in] deep

Figure 5: OMSW with side port and check valve

Type	L ₁ mm [in]	L ₂ mm [in]	L ₃ mm [in]
OMSW 125	21.8 [0.86]	58.8 [2.31]	100.2 [3.94]
OMSW 160	27.8 [1.09]	64.8 [2.55]	106.2 [4.18]
OMSW 200	34.8 [1.37]	71.8 [2.83]	113.2 [4.46]
OMSW 250	43.5 [1.71]	80.5 [3.17]	121.9 [4.80]
OMSW 315	54.8 [2.16]	91.8 [3.61]	133.2 [5.24]
OMSW 400	68.4 [2.69]	105.4 [4.15]	146.8 [5.78]
OMSW 500	68.4 [2.69]	105.4 [4.15]	146.8 [5.78]

OMSW with side port and drain connection

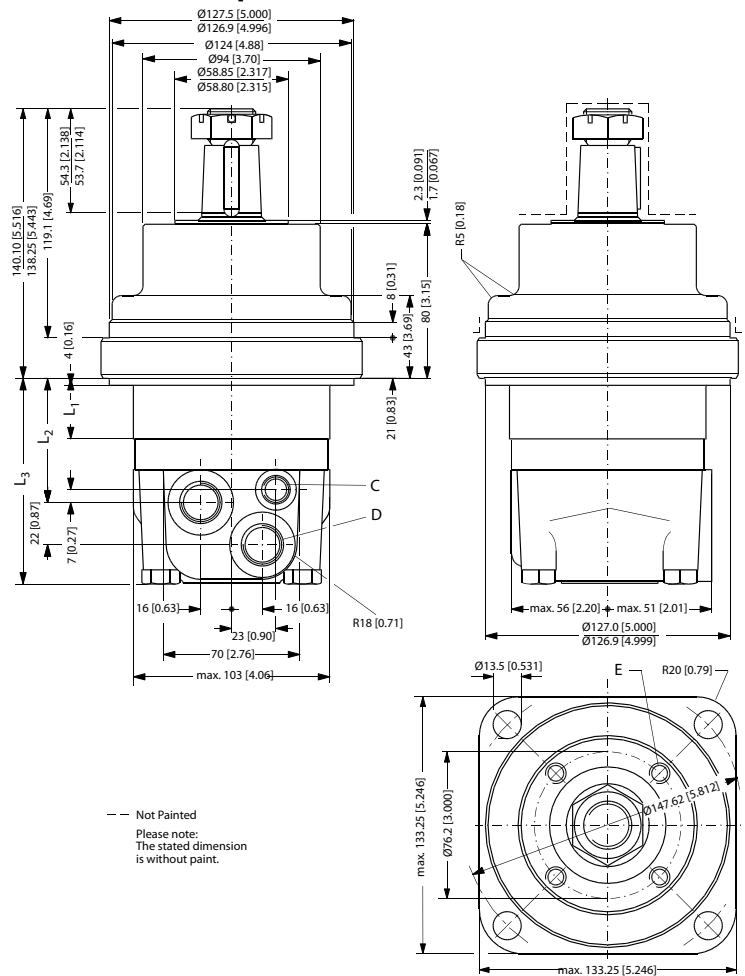

151-2000.13

C: 7/16 - 20 UNF; 11.43 mm [0.45 in] deep

D: 7/8 - 14 UNF; 16.76 mm [0.66 in] deep O-ring boss port

E: Thread for external brake 4 x 5/16 - 18 UNC; 13 mm [0.51 in] deep

Figure 6: OMSW with side port and drain connection

Type	L ₁ mm [in]	L ₂ mm [in]	L ₃ mm [in]
OMSW 125	21.8 [0.86]	58.8 [2.31]	100.2 [3.94]
OMSW 160	27.8 [1.09]	64.8 [2.55]	106.2 [4.18]
OMSW 200	34.8 [1.37]	71.8 [2.83]	113.2 [4.46]
OMSW 250	43.5 [1.71]	80.5 [3.17]	121.9 [4.80]
OMSW 315	54.8 [2.16]	91.8 [3.61]	133.2 [5.24]
OMSW 400	68.4 [2.69]	105.4 [4.15]	146.8 [5.78]
OMSW 500	68.4 [2.69]	105.4 [4.15]	146.8 [5.78]

OMSW with end port and check valve

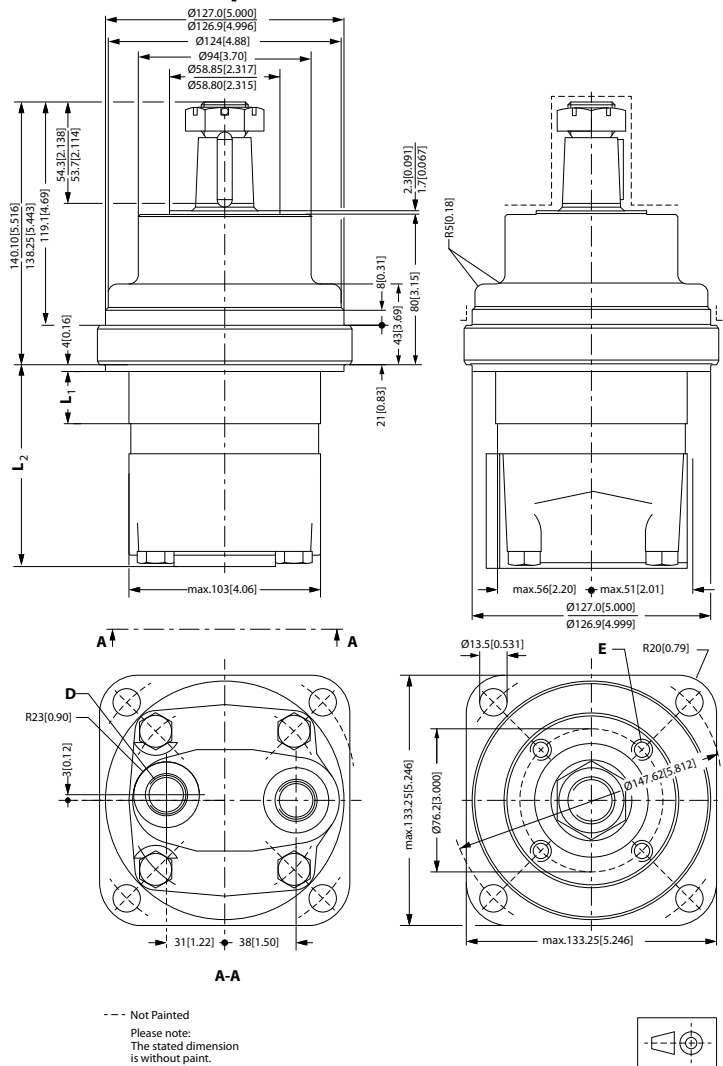

D: 7/8 - 14 UNF; 16.76 mm [0.66 in] deep O-ring boss port

E: Thread for external brake 4 x 5/16 - 18 UNC; 13 mm [0.51 in] deep

Figure 7: OMSW with end port and check valve

Type	L ₁ mm [in]	L ₂ mm [in]
OMSW 125	21.8 [0.86]	101.8 [4.01]
OMSW 160	27.8 [1.09]	107.8 [4.24]
OMSW 200	34.8 [1.37]	114.8 [4.52]
OMSW 250	43.5 [1.71]	123.5 [4.86]
OMSW 315	54.8 [2.16]	134.8 [5.31]
OMSW 400	68.4 [2.69]	148.4 [5.84]
OMSW 500	68.4 [2.69]	148.4 [5.84]

OMSW with end port and drain connection

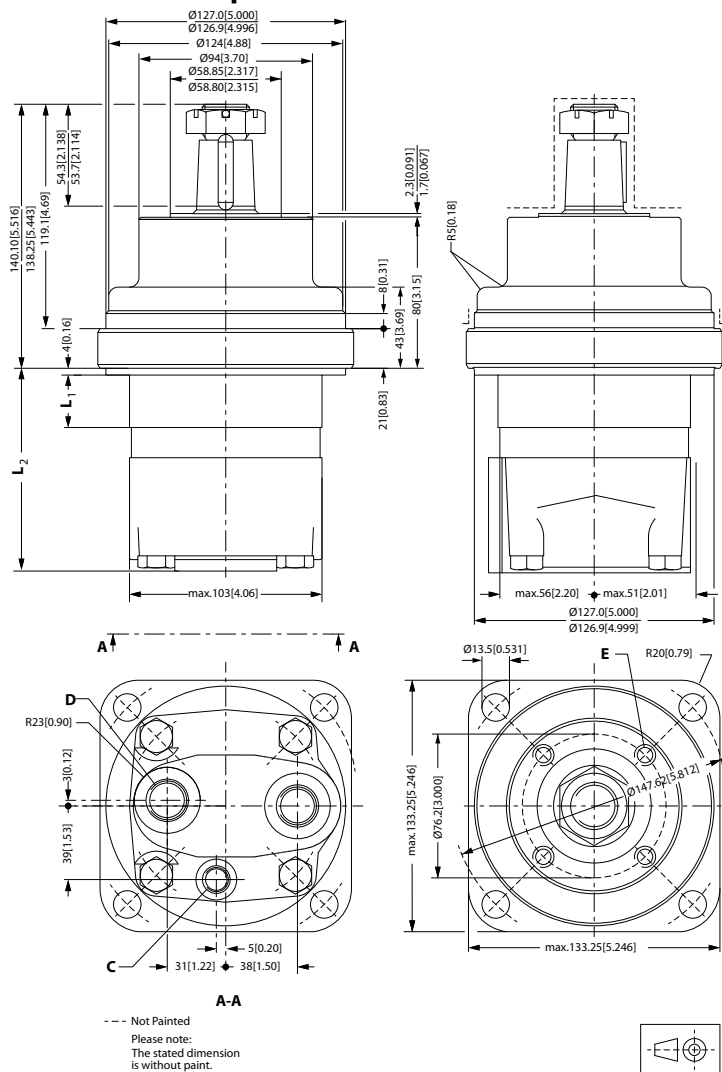

C: 7/16 - 20 UNF; 11.43 mm [0.45 in] deep

D: 7/8 - 14 UNF; 16.76 mm [0.66 in] deep O-ring boss port

E: Thread for external brake 4 x 5/16 - 18 UNC; 13 mm [0.51 in] deep

Figure 8: OMSW with end port and drain connection

Type	L ₁ mm [in]	L ₂ mm [in]
OMSW 125	21.8 [0.86]	101.8 [4.01]
OMSW 160	27.8 [1.09]	107.8 [4.24]
OMSW 200	34.8 [1.37]	114.8 [4.52]
OMSW 250	43.5 [1.71]	123.5 [4.86]
OMSW 315	54.8 [2.16]	134.8 [5.31]

Type	L ₁ mm [in]	L ₂ mm [in]
OMSW 400	68.4 [2.69]	148.4 [5.84]
OMSW 500	68.4 [2.69]	148.4 [5.84]

Chapter

6

Weight of motors

Code no	Weight kg [lb]
151F2502	10.8 [23.8]
151F2503	11.2 [24.7]
151F2504	11.6 [25.6]
151F2505	12.1 [26.7]
151F2506	12.8 [28.2]
151F2507	13.6 [30.0]
151F2508	13.6 [30.0]
151F2512	10.8 [23.8]
151F2513	11.2 [24.7]
151F2514	11.6 [25.6]
151F2515	12.1 [26.7]
151F2516	12.8 [28.2]
151F2517	13.6 [30.0]
151F2518	13.6 [30.0]
151F2522	10.8 [23.8]
151F2523	11.2 [24.7]
151F2524	11.6 [25.6]
151F2525	12.1 [26.7]
151F2526	12.8 [28.2]
151F2527	13.6 [30.0]

Code no	Weight kg [lb]
151F2528	13.6 [30.0]
151F2532	10.8 [23.8]
151F2533	11.2 [24.7]
151F2534	11.6 [25.6]
151F2535	12.1 [26.7]
151F2536	12.8 [28.2]
151F2537	13.6 [30.0]
151F2538	13.6 [30.0]