



Italgroup[®]

**HYDRAULIC MOTORS
ITALY**

HIGH AND LOW SPEED RADIAL PISTON MOTORS



OIL SOLUTIONS

1800-OILSOL
1800-645765

<https://oilsolutions.com.au/>

sales@oilsolutions.com.au

G/GD

HIGH AND LOW SPEED RADIAL PISTON MOTORS

COMPANY GENERAL INFORMATION



We produce RADIAL PISTON HYDRAULIC MOTORS since 1985: our yearly production is more than 13.000 units which we sell all over the world through our agents and authorized sellers. Our motor range varies from 20cc to 8500cc displacement and it is completed by two-speed motors and special motors created in cooperation with our clients for different applications such as : underwater, high & low speed and wheel motors and with the possibility to assemble valves, brakes or gear reductions. You can directly contact our Technical Department which will give you all the necessary support to find the right solutions to your problems.

ITALGROUP is a flexible work reality and manages deliveries also within the same day of order; we produce motors exactly interchangeable with our competitors, always ready on stock which our clients particularly appreciate.



Complete groups



Coal mining application



Injection moulding machine



Coal mining roader head



Hydraulic winch

ITALGROUP is a flexible work reality and manages deliveries also within the same day of order; we produce motors exactly interchangeable with our competitors, always ready on stock which our clients particularly appreciate.

***HIGH AND LOW SPEED RADIAL PISTON
 MOTORS
 G SERIES / GD SERIES
 TECHNICAL CATALOGUE***



G 20-27-34
G 50-75-90-100

GD 100

INDEX

| | | |
|---|-------------|----|
| COMPANY GENERAL INFORMATION - - - - - | <i>Pag.</i> | 1 |
| MOTOR TECHNICAL DATA - - - - - | " | 3 |
| FLUID RECOMMENDATION - - - - - | " | 4 |
| INSTRUCTION AND ADVICES - - - - - | " | 5 |
| FLUSHING - - - - - | " | 8 |
| DRAIN RECOMMENDATION - - - - - | " | 9 |
| SHAFT SEAL FEATURES - - - - - | " | 10 |
| FORMULAS / UNIT CONVERSIONS - - - - - | " | 11 |
| G SERIES TECHNICAL DATA - - - - - | " | 12 |
| - <i>G SERIES - SIZE & SHAFT -</i> | | |
| G 20-27-34 - - - - - | " | 13 |
| G 50-75-90-100 - - - - - | " | 14 |
| G SERIES ORDERING INSTRUCTIONS - - - - - | " | 15 |
| GD SERIES TECHNICAL DATA - - - - - | " | 16 |
| - <i>GD SERIES - SIZE & SHAFT -</i> | | |
| GD 100 - - - - - | " | 17 |
| GD SERIES ORDERING INSTRUCTIONS - - - - - | " | 18 |
| TACHOMETER / SPLINE BILLETS - - - - - | " | 19 |
| CONTACT US / REACH US - - - - - | " | 20 |

MOTOR TECHNICAL DATA

G series

Single displacement motor

| Model | G20 | G27 | G34 | G50 | G75 | G90 | G100 |
|--------------------------------------|------|------|------|------|------|------|------|
| Displacement [cc/Rev] | 20,5 | 27,3 | 34,2 | 50,9 | 76,3 | 89 | 102 |
| Specific theoretical torque [Nm/bar] | 0,32 | 0,43 | 0,54 | 0,81 | 1,21 | 1,41 | 1,61 |
| Maximum speed [rpm] | 2500 | 2500 | 2500 | 2400 | 2300 | 2200 | 2200 |
| Minimum speed [rpm] | 40 | 35 | 30 | 25 | 20 | 15 | 10 |
| Mechanical efficiency [%] | 84 | 87 | 88,5 | 88 | 89 | 89.2 | 89.5 |
| Starting mechanical efficiency [%] | 78 | 84 | 85,8 | 80 | 85 | 86 | 87 |
| Continuous maximum power [kW] | 10 | 14 | 17 | 25 | 35 | 42 | 48 |
| Maximum power [kW] | 12 | 17 | 21 | 31 | 44 | 52 | 60 |
| Continuous maximum pressure [bar] | 250 | 250 | 250 | 250 | 250 | 250 | 250 |
| Intermittent maximum pressure [bar] | 280 | 280 | 280 | 280 | 280 | 280 | 280 |
| Peak pressure [bar] | 350 | 350 | 350 | 350 | 350 | 350 | 350 |
| Dry weight | 19 | 19 | 19 | 25 | 25 | 25 | 25 |
| Recommended flushing flow [l/min] | 3 | 3 | 3 | 3 | 5 | 5 | 5 |

GD series

Dual displacement motor

| | | | | | |
|--------------------------------------|------|------|------|------|------|
| Max displacement [cc/Rev] | 100 | 89 | 76,3 | 63,6 | 50,3 |
| Specific theoretical torque [Nm/bar] | 1,61 | 1,41 | 1,21 | 1,01 | 0,81 |
| Maximum speed [rpm] | 1850 | 1900 | 2000 | 2100 | 2300 |
| Minimum speed [rpm] | 10 | 15 | 20 | 25 | 25 |
| Mechanical efficiency [%] | 89.5 | 89.2 | 89 | 88.5 | 88 |
| Starting mechanical efficiency [%] | 87 | 86 | 85 | 82 | 80 |
| Continuous maximum power [kW] | 48 | 42 | 35 | 31 | 25 |
| Maximum power [kW] | 60 | 52 | 44 | 39 | 31 |
| Continuous maximum pressure [bar] | 250 | 250 | 250 | 250 | 250 |
| Intermittent maximum pressure [bar] | 280 | 280 | 280 | 280 | 280 |
| Peak pressure [bar] | 350 | 350 | 350 | 350 | 350 |
| Dry weight | 25 | 25 | 25 | 25 | 25 |
| Recommended flushing flow [l/min] | 5 | 5 | 5 | 5 | 3 |

| | | | |
|--------------------------------------|------|------|------|
| Min displacement [cc/Rev] | 50,3 | 38 | 31 |
| Specific theoretical torque [Nm/bar] | 0,81 | 0,6 | 0,49 |
| Maximum speed [rpm] | 2300 | 2350 | 2400 |
| Minimum speed [rpm] | 25 | 30 | 30 |
| Mechanical efficiency [%] | 88 | 85 | 83 |
| Starting mechanical efficiency [%] | 80 | 75 | 45 |
| Continuous maximum power [kW] | 25 | 18 | 15 |
| Maximum power [kW] | 31 | 23 | 19 |
| Continuous maximum pressure [bar] | 250 | 250 | 250 |
| Intermittent maximum pressure [bar] | 280 | 280 | 280 |
| Peak pressure [bar] | 350 | 350 | 350 |
| Dry weight | 25 | 25 | 25 |
| Recommended flushing flow [l/min] | 3 | 3 | 3 |

The G & GD motors are radial piston hydraulic motors that can be used for different applications, both general and specific ones. The G & GD series is characterized by high speed, high volumetric efficiency and high starting torque. G & GD motors can be used for both mobile and industrial applications, we can supply them in complete groups, together with gearboxes and negative brakes. Special features like high pressure bidirectional shaft seals and special treatment on motors can be performed. Please contact ItalgrouP technical department for more information.

HYDRAULIC FLUIDS RECOMMENDATIONS

HYDRAULIC FLUIDS

We recommend the use of hydraulic oils with anti-wear additives (ISO HM or HV) and minimum viscosity index of 95. Once normal working temperature is reached, oil viscosity must be at least 44 cSt, preferably in the range from 50 to 80 cSt.

Hydraulic oils meeting Denison MF-O, Vickers M-2952-S I - 286-S performance requirements and DIN 51524 specifications, are preferred.

Pay particular attention if you use HE type oils (ecological fluid) because they can influence the motor seals compatibility, the motor performance and life. Please ask us for advice in case of HE type oils usage.

Mineral hydraulic oils are divided into four main types, designated by the International Standards Organisation (ISO) as HH, HL, HM and HV. We advise to use only products with HM or HV specifications.

HM type

These are the most widely employed hydraulic oils. They include small quantities of anti-wear additives to provide significant improvement in wear reduction. "Superior" quality HM type oils can be used for all equipment, with the added assurance that they will be suitable for the highest temperature.

HV type

HV hydraulic oils show minimal change in viscosity with temperature variations.

OIL VISCOSITY RECOMMENDATION

Room temperature HM type ISO-VG

- -20°C / 0°C BP ENERGOL HLP - HM 22
- -15°C / +5°C BP ENERGOL HLP - HM 32
- -8°C / +15°C BP BNERGOL HLP - HM 46
- 0°C / +22°C BP ENERGOL HLP - HM 68
- +8°C / +30°C BP ENERGOL HLP - HM100
- -20°C / +5°C BP BARTRAN HV 32
- -15°C / +22°C BP BARTRAN HV 46
- 0°C / +30°C BP BARTRAN HV 68

Our motors have been designed to work also with:

- oils type ATF (Automatic Transmission Fluid)
- oils with viscosity SAE 10W - 20 -30
- multigrade motor oils SAE 10 W/40 or 15 W/40
- universal oils

During cold start-up, avoid high-speed operation until the system is warmed up to provide adequate lubrication. Continuous working temperature must not exceed 70°C.

FIRE RESISTANT OIL LIMITATIONS

| | Max cont. pressure | Max int. pressure | Max speed |
|-----------------------|--------------------|-------------------|-----------|
| HFA, 5-95% oil-water | 103 | 138 | 50% |
| HFB, 60-40% oil-water | 138 | 172 | 100% |
| HFC, water-glycol | 103 | 138 | 50% |
| HFD, ester phosphate | 250 | 293 | 100% |

FILTRATION

Hydraulic systems oil must always be filtered.

The choice of filtration grade derives from needs of service life and money spent. In order to obtain stated service life it is important to follow our recommendations concerning filtration grade.

When choosing the filter it is important to consider the amount of dirt particles that filter can absorb and still operate satisfactorily. For that reason we recommend filters showing when you need to substitute filtering cartridge.

According to NAS 1628, we recommend:

- maximum permissible oil contamination degree according to NAS 1628 class 9 (using filters with minimum efficiency $\beta_{10}=100$), for normal service life;
- maximum permissible oil contamination degree according to NAS 1628 class 8 (using filters with minimum efficiency $\beta_5=100$), for closed circuit applications and long service life.

OXIDATION

Hydraulic oil oxidizes with time of use and temperature. Oxidation causes changes in colour and smell, acidity increase or sludge formation in the tank. Oxidation rate increases rapidly at surface temperatures above 60°C, in these situations oil should be checked more often. Every 5-8°C of increase from the optimum working temperature, the hydraulic fluid life decrease of about 40-50%.

The oxidation process increases the acidity of the fluid; the acidity is stated in terms of the "neutralization number". Oxidation is usually slow at the beginning and then it increases rapidly.

A sharp increase (by a factor of 2 to 3) in neutralization number between inspections shows that oil has oxidized too much and should be replaced immediately.

WATER CONTENT

Oil contamination by water can be detected by sampling from the bottom of the tank. Most hydraulic oils repel the water, which then collects at the bottom of the tank. This water must be drained off at regular intervals. Certain types of transmission oils and engine oils emulsify the water; this can be detected by coatings on filter cartridges or a change in the colour of the oil. In such cases, obtain your oil supplier advice.

DEGREE OF CONTAMINATION

Heavy contamination of the oil causes wear rising in hydraulic system components. Contamination causes must be immediately investigated and remedied.

ANALYSIS

In optimum operating conditions, we recommend to perform an oil analysis 6 months. The analysis should cover viscosity, oxidation, water content, additives and contamination. Most oil suppliers are equipped to analyze oil state and to recommend appropriate action. Oil must be immediately replaced if the analysis shows that it is exhausted.

INSTRUCTIONS AND ADVICES

INSTALLATION

Hoses and piping must be clean and free from contamination. The motor must be fitted on a flat, robust surface using the right bolts (see the following table for your reference).

| Motor | Bolts | Bolts preload |
|---------------|-------|---------------|
| G / GD series | M8 | 20÷30 Nm |

The clearance between the motor flange diameter and the mounting diameter must not exceed a maximum value that can be set approximatively to 0.15 mm. In special working conditions, in which the motor is operating with frequent reversing, high speed running, vibrations, and shock loadings, high tensile stress fixing bolts must be used, whereas one must be included as fitting bolt.

In the case in which the motor is coupled in a rigid way to a shaft having independent bearings, the two shafts must be aligned in the way to have a maximum error of about 0.1 mm.

- Motor can be mounted in any position (refer to drain recommendations to obtain more detailed guidelines)
- In run-away conditions you must use counterbalance valves
- Consult factory for intermittent applications

Splined adaptors (splined billets) are available upon request.

INSTALLATION CIRCUIT

The choice of open or closed loop circuit will be determined by the application.

Open loop circuits are cheaper and simpler to install.

Closed loop circuit is a superior circuit and usually takes up less space. It also offers better control features. In case of using closed loop circuit please contact ItalgrouP technical department.

START UP

Motor case and pistons must be completely filled with oil before starting. Do not load motor to maximum working pressure. Increase load gradually at start-up. When it is possible, a short "running in" period of 30 minutes is highly recommended (for GD series, this operation must be performed keeping the motor in maximum displacement).

CASE DRAIN – CASE PRESSURE

Referring to drain pipes, the recommended minimum size for pipe lengths up to about 5 m is 12 mm as internal diameter. If the drain pipes are longer, the internal bore drain pipe diameter must be increased by consequence. Keep the pipe length always at the minimum possible value, connecting the case drain directly to tank.

The case drain port on the motor must be located on the highest point of the installation to ensure that the motor will always be full of oil. ItalgrouP G and GD motors are equipped with high pressure shaft seal: refer to the "shaft seal features" page for the maximum continuous case pressure estimation. ItalgrouP performed internal tests that shows that the case pressure can be up to 10 bar continuous and 15 bar intermittent without causing damage to the shaft seal. Especially in the case in which the drain line is quite long, a relief valve is recommended to prevent the shaft seal damage.

IMPORTANT

When the motor is installed vertically with shaft pointing upwards, consult our Technical Department. If the motor is connected to high inertial loads, the hydraulic system must be designed to prevent peaks of pressure and cavitation.

TEMPERATURE

Refer to hydraulic fluid recommendations.

VISCOSITY

Refer to hydraulic fluid recommendations.

HIGH PRESSURE APPLICATIONS

In case of high pressure applications, a Nitemper treatment on motor body it is suggested to increase wear and tear resistance.

BACK PRESSURE

Don't exceed 70 bar back pressure. A small return line back pressure between 2 and 5 bar is recommended in some cases to attenuate the liquid born noise level. In addition the back pressure counteract the centrifugal forces in the motor. Please notice that the back pressure reduces the effective motor output torque.

BOOST PRESSURE

When the motor runs at a speed that can cause pumping effects, a positive pressure it is needed at the motor ports. The minimum required pressure at the motor ports can be estimated basing on different parameters, using the following formula:

$$p = 1 + p_c + C_H n^2 V^2$$

Where p is the boost pressure, p_c the case pressure, n the rotation speed, V the motor displacement, and C_H is a constant, depending by the motor serie.

| Motor | C _H |
|----------------|-----------------------|
| G 20-27-34 | 0,25*10 ⁻⁹ |
| G 50-75-90-100 | 0,28*10 ⁻⁹ |
| GD 100 | 0,28*10 ⁻⁹ |

MINIMUM SPEED

The minimum acceptable speed depends by different variables, like load inertia, motor displacement, system leakages, etc... For indicative values refer to motor technical data. For GD series, when it is possible, always start the motor in high displacement, to avoid start-up problems.

GD SERIES - DISPLACEMENT CHANGE

The displacement change can be performed in different ways. The user can use an internal or external pilot. To perform the displacement change, the pilot pressure must be at least 2/3 of the motor working pressure. If the motor working pressure is less than 3,5 bar, the pilot pressure must be at least 3,5 bar. Please note that in freewheeling operation it is necessary supply the displacement control mechanism with an external supply pressure/flow source. This external supply source will assure that the motor displacement during the freewheeling operation remains fixed at the minimum value, avoiding GD motor damage.

The oil flow rate required to perform the displacement change can be estimated in function of many different parameters; the most important factor that determinate the required flow rate is the motor case internal leakage. The flow rate that is shown in the next table must be considered as an indicative value that depends by many system parameters and working conditions.

| Motor | Required flow rate | Displacement change delay |
|--------|--------------------|---------------------------|
| GD 100 | 5 l/min | 0,2 s |

The system components (pumps, motors...) present tear and wear phenomenons that are clearly variables during the system life, so the required flow rate is variable during the motor life, this variation is very difficult to estimate: for this reason the values reported must be considered as approximated and indicative values.

DISPLACEMENT CHANGE HYDRAULIC CIRCUIT

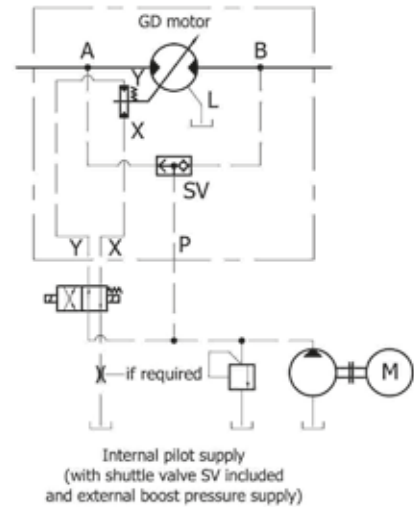
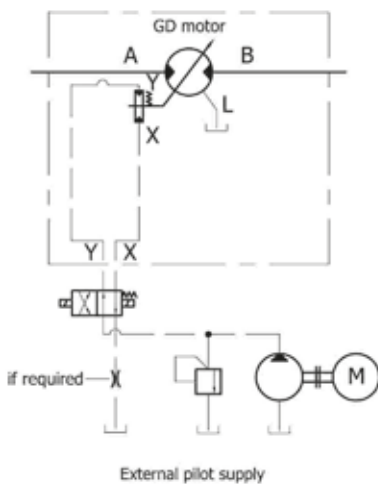
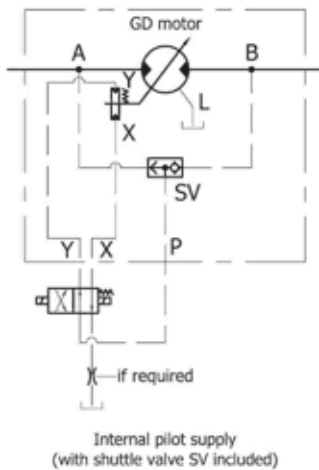

SMALL DISPLACEMENT/FREEWHEELING OPERATION

Selecting a GD series hydraulic motor with a minimum displacement very small (31 cc), the motor can run without load at high speed, resulting in a minimum motor torque requirement. The motor ports must be connected together (refer to the following diagram) and must be supplied with an external pressure/flow source.

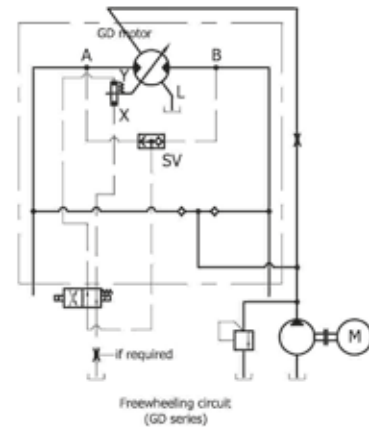

Selecting a G series hydraulic motor, the following circuit represents the best choice for freewheeling operation. The motor works under vacuum conditions, therefore it can work several hours without causing any damage and overheating. The switch from normal operation (and viceversa) must be done at low speed and pressure. Consult Italgrou technical department to obtain more details.

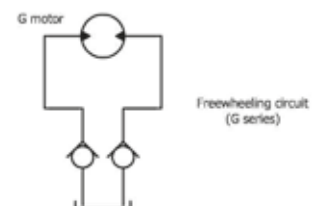

When the motor is running at high speed, a minimum pressure must exist at the motor ports (see boost pressure paragraph), but in all cases this pressure must not exceed the maximum working pressure reported in the zero displacement code motor technical data. A crankcase flushing flow is highly recommended in freewheeling operation, to control and reduce the motor temperature rise during the freewheeling. If the motor running speed is between 1000 and 2500 rpm, a 10 l/min (indicative value) flushing flow is compulsory.

BEARINGS

The bearing life depends by different factors, like bearing type, motor speed, working pressure, external loads, duty cycle, fluid viscosity, cleanliness, type and temperature. Lifetime is measured by L_{10} which is called "theoretic lifetime". It represents the number of cycles that 90% of identical bearings can effort at the same load without showing wear and tear. It is calculated by the following equation:

$$L_{10} = \left(\frac{C}{P}\right)^p$$

where: C = theoretical dynamic coefficient (depending on the bearing size)

P = radial load

p = exponent (p=3 for ball bearings, p=10/3 for roller bearings)

When you work at constant speed, you can calculate the lifetime in hours with the following equation:

$$L_{10h} = \frac{10^6 \cdot L_{10}}{60 \cdot \text{rpm}} = \frac{10^6}{60 \cdot \text{rpm}} \left(\frac{C}{P}\right)^p \text{ [h]}$$

When you don't have only radial or axial loads, you have to calculate an equivalent load:

$$P = X \cdot F_R + Y \cdot F_A$$

Where

F_R = radial load,

X = radial coefficient,

F_A = axial load,

Y = axial coefficient

While F_R and F_A come from working conditions (i.e. torque), X

and Y depend on the type of bearing and on the ratio $\frac{F_A}{F_R}$.

L_{10} is a theoretical value, that must be corrected to take into account other important parameters, that in most applications are very difficult to estimate.

| Motor | Bearing medium diameter |
|----------------|-------------------------|
| G 20-27-34 | 45 mm |
| G 50-75-90-100 | 50 mm |
| GD 100 | 50 mm |

Starting from the L_{10} or L_{10h} , that are theoretical values, you can obtain a more accurate bearing lifetime estimation, supposing that the oil has a very low contamination level (refer to hydraulic fluid recommendation), using the following formula:

$$L_{na} = a_v L_{10} / f_s$$

a_v is the viscosity factor, and can be estimated referring to

the following diagram, whereas f_s is the service factor, that is dependent by the duty cycle (refer to the service factor table).

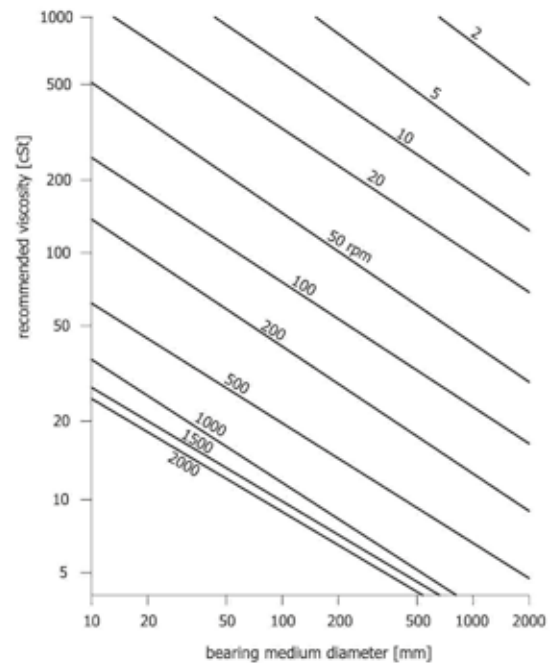

| Continuous working duty cycle | Service factor (f_s) |
|-------------------------------|--------------------------|
| < 6 h | 1.2 |
| < 12 h | 1.4 |
| < 24 h | 2.8 |

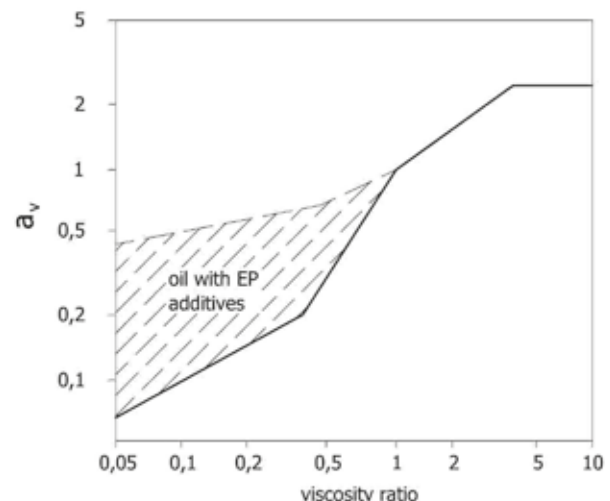

For further information, please contact our technical department.

FLUSHING

FLUSHING FLOW

Cooling flow is necessary to assure the minimum oil viscosity and depends by motor displacement. On radial piston hydraulic motors with high volumetric efficiency, and therefore Italgroup G and GD series, there can be a phenomenon of oil-overheating in the body motor. In fixed applications, for example, where the motor is running constantly for 8 or more hours a day (like injection machines for plastic materials, press, bending machines, etc.) high volumetric efficiency can create temperature increasing in motor body. In this case temperature increasing is to be avoided with the use of flushing. Flushing consists in carrying fresh oil (taken from hydraulic circuit) in the body motor. Oil is usually taken from return line to avoid any loss of efficiency. In this way, all internal parts of the motor are protected with this lubrication and cooled with fresh oil, so that total efficiency is optimised.

In the following table you can find an indicative value for G and GD series. The required flushing flow must always be set to assure that the oil viscosity is equal or higher than the recommended value.

| Motor | Flushing flow [l/min] |
|----------------|-----------------------|
| G 20-27-34 | 3 |
| G 50-75-90-100 | 5 |
| GD 100 | 3÷5 |

FLUSHING IN PERFORMANCE DIAGRAMS

Please contact Italgroup technical department to obtain the performance diagrams.

DRAIN RECOMMENDATIONS

Motor axis horizontal

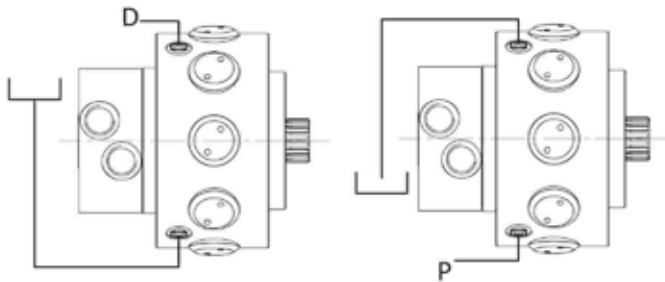

Axis vertical, shaft up

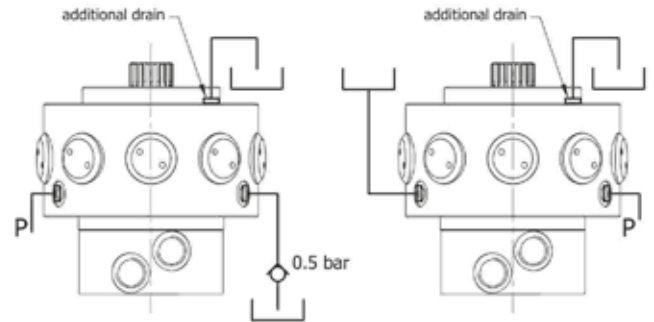

Axis vertical, shaft down

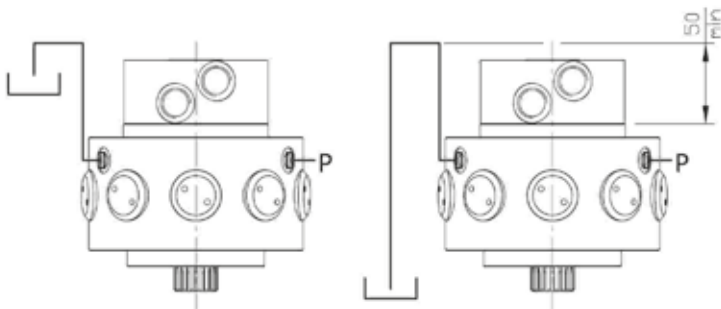

P=plug D=drain

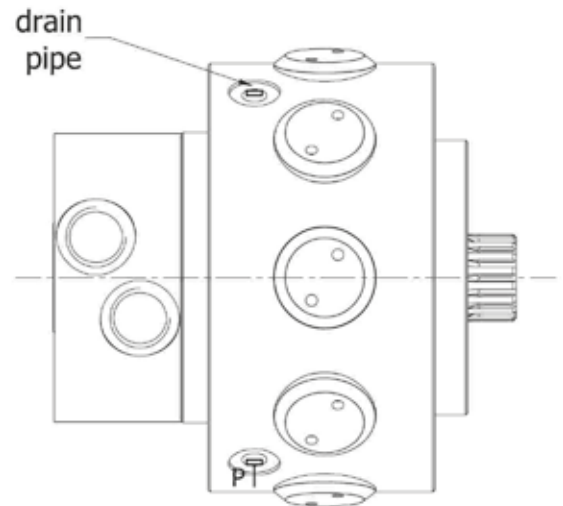

IMPORTANT

For all motors G/GD series, it is necessary **TO FILL** the motor case with hydraulic fluid, through the drain pipe, before start-up.

SHAFT SEAL FEATURES

Type: BABSL
Form: AS DIN 3760
Material: SIMRIT[®] 72 NBR 902
SIMRIT[®] 75 FKM 595

1. Features

SIMMERRING[®] radial shaft seal with rubber covered O.D., short, flexibility suspended, spring loaded sealing lip and additional dust lip: see Part B/ SIMMERRING[®], sections 1.1 and 2.

2. Material

Sealing lip and O.D.:

- Acrylonitrile-butadiene rubber with 72 Shore A hardness (designation: SIMRIT[®] 72 NBR 902)
- Fluoro rubber with 75 Shore A hardness (designation: SIMRIT[®]75 FKM 595)

Metal insert:

- Plain steel DIN 1624

Spring:

- Spring steel DIN 17223

3. Application

For sealing pressurised media without additional backup ring, e. g. for rotational pressure sealing in hydraulic pumps, hydraulic motors, hydrodynamic clutches. Rubber covered O.D. assures sealing in the housing bore even in case of considerable surface roughness, thermal expansion or split housing.

Particularly suitable for sealing low viscosity and gaseous media.

Where high thermal stability and chemical resistance are required, SIMRIT[®] 75 FKM 595 material should be used. Additional dust lip to avoid the entry of light and medium dust and dirt.

4. Operating conditions

See Part B/ SIMMERRING[®], sections 2. 4.

Media: mineral oils, synthetic oils

Temperature: -40°C to +100°C (SIMRIT[®] 72 NBR 902)
-40°C to +160°C (SIMRIT[®] 75 FKM 595)

Surface speed: up to 5 m/s

Working pressure: see diagram 1

Maximum permitted values, depending on other operating conditions.

5. Housing and Machining Criteria

See Part B/ SIMMERRING[®], sections 2.

| | | |
|----------|----------------|---|
| Shaft: | Tolerance: | ISO h11 |
| | Concentricity: | IT 8 |
| | Roughness: | Ra=0.2-0.8 µm Rz=1-4 µm Rmax=6 µm |
| grinding | Hardness: | 45-60 HRC |
| | Roughness: | non oriented; preferably by plunge |
| | | |
| Housing: | Tolerance: | ISO H8 |
| | Roughness: | Rmax<25 µm |

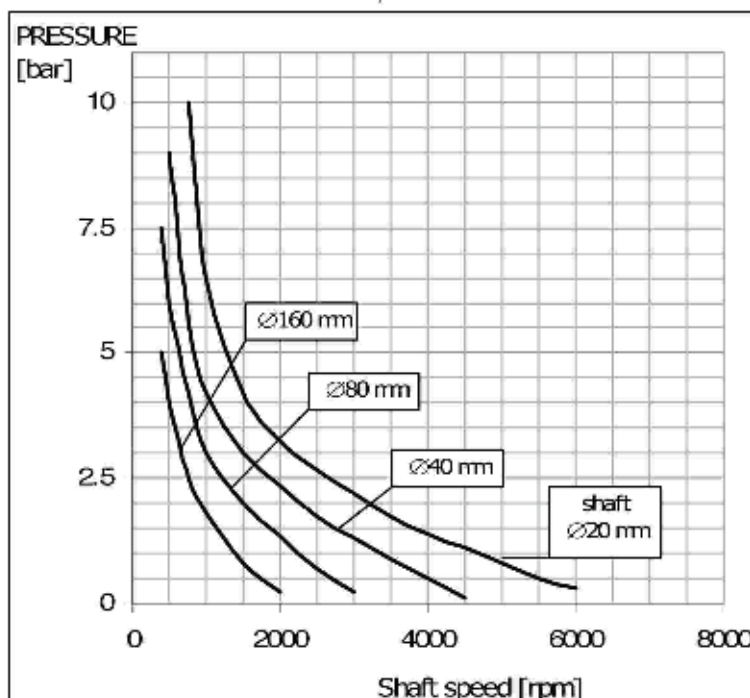

Diagram 1: Pressure Loading Limits

FORMULAS

| | |
|-------------------------------|--|
| • TORQUE (1) | Torque = (specific torque) · (pressure) |
| • TORQUE (2) | Torque [Nm] = $\frac{\text{displacement [cc/rev]} \cdot \text{pressure [bar]}}{62.8}$ |
| • POWER (1) | Power [kW] = $\frac{\text{Torque [Nm]} \cdot \text{speed [rpm]}}{9549}$ |
| • POWER (2) | Power [CV] = $\frac{\text{Torque [Nm]} \cdot \text{speed [rpm]}}{7023}$ |
| • SPEED | speed [rpm] = $\frac{\text{flow rate [l/min]} \cdot 1000}{\text{displacement [cc/rev]}}$ |
| • REQUIRED MOTOR DISPLACEMENT | displacement [cc/rev] = $\frac{\text{max required torque [Nm]} \cdot 62.8}{\text{max pressure [bar]}}$ |
| • REQUIRED PUMP FLOW RATE | flow [l/min] = $\frac{\text{displacement [cc/rev]} \cdot \text{max speed [rpm]}}{1000}$ |

CONVERSIONS

| | | |
|---------------|---|---|
| LENGTH | 1 m = 39.3701 in = 3.2808 ft = 1.0936 yd = 1000 mm | 1 lbf = 0.4536 kgf = 4.448 N |
| | 1 in = 0.0833 ft = 25.4 mm | PRESSURE |
| | 1 ft = 0.3048 m = 0.3333 yd = 12 in | 1 bar = 14.223 psi = 0.99 atm = 1.02 ata = 100000 Pa = 100 kPa = 0.1 MPa |
| | 1 yd = 0.9144 m = 3 ft = 36 in | 1 psi = 0.0703 bar |
| | 1 km = 1000 m = 1093.6 yd = 0.6214 mile | FLOW |
| | 1 mile = 1.609 km = 1760 yd | 1 l/min = 0.264 gpm = 1000 cc/min |
| MASS | 1 kg = 2.2046 lb 1 lb = 0.4536 kg | 1 gpm = 3.785 l/min = 3785 cc/min |
| SPEED | 1 m/s = 3.6 km/h = 2.237 mph = 3.2808 ft/s | 1 m ³ /s = 60000 l/min = 15852 gpm |
| | 1 km/h = 0.2778 m/s = 0.6214 mph = 0.9113 ft/s | VOLUME |
| | 1 mph = 1.609 km/h = 0.447 m/s = 1.467 ft/s | 1 m ³ = 1000 l 1 l = 61,023 in ³ = 0,264 galUS |
| | 1 ft/s = 0.3048 m/s = 1.0973 km/h = 0.6818 mph | 1 in ³ = 0,01639 l = 16,39 cm ³ = 0,004326 galUS |
| FORCE | 1 N = 0.102 kgf = 0.2248 lbf | 1 galUS = 3,7879 l = 231,15 in ³ |
| | 1 kgf = 2.205 lbf = 9.806 N | POWER |
| | | 1 kW = 1.341 HP = 1.3596 CV |
| | | 1 HP = 0.7457 Kw = 1.0139 CV |
| | | TORQUE |
| | | 1 Nm = 0.102 kgm = 0.7376 lbf ft |
| | | 1 kgm = 9.806 Nm = 7.2325 lbf ft |
| | | 1 lbf ft = 0.1383 kgm = 1.3558 Nm |

TECHNICAL DATA

G

| MODEL | | G 20 | G 27 | G 34 | G 50 | G 75 | G 90 | G 100 |
|----------------------|--------|------|------|------|------|------|------|-------|
| Displacement | cc/rev | 20,5 | 27,3 | 34,2 | 50,9 | 76,3 | 89 | 102 |
| Specific Torque | Nm/bar | 0,32 | 0,43 | 0,54 | 0,81 | 1,21 | 1,41 | 1.61 |
| Max cont. Pressure | bar | 250 | 250 | 250 | 250 | 250 | 250 | 250 |
| Max int. Pressure | bar | 280 | 280 | 280 | 280 | 280 | 280 | 280 |
| Peak pressure | bar | 350 | 350 | 350 | 350 | 350 | 350 | 350 |
| Max continuous speed | rpm | 2400 | 2400 | 2400 | 2300 | 2150 | 2000 | 1900 |
| Peak speed | rpm | 2500 | 2500 | 2500 | 2400 | 2300 | 2200 | 2200 |
| Minimum speed | rpm | 40 | 35 | 30 | 25 | 20 | 15 | 10 |
| Dry weight | kg | 19 | 19 | 19 | 25 | 25 | 25 | 25 |
| Max power | HP | 17 | 24 | 28 | 42 | 59 | 71 | 82 |
| | kW | 12 | 17 | 21 | 31 | 44 | 52 | 60 |

- N° of pistons: 9
- Max case pressure: 6 bar
- Max back pressure: 70 bar
- Temperature range: -30°C ÷ +70°C

When the motor continuously works at high power values, motor flushing is needed (see performance diagrams). The recommended flushing flow is 3 l/min (G20, G27, G34), and 5 l/min (G50, G75, G90, G100).

For further information please contact Italgrou®** technical department.**

SIZE

G 20-27-34

SINGLE DISPLACEMENT

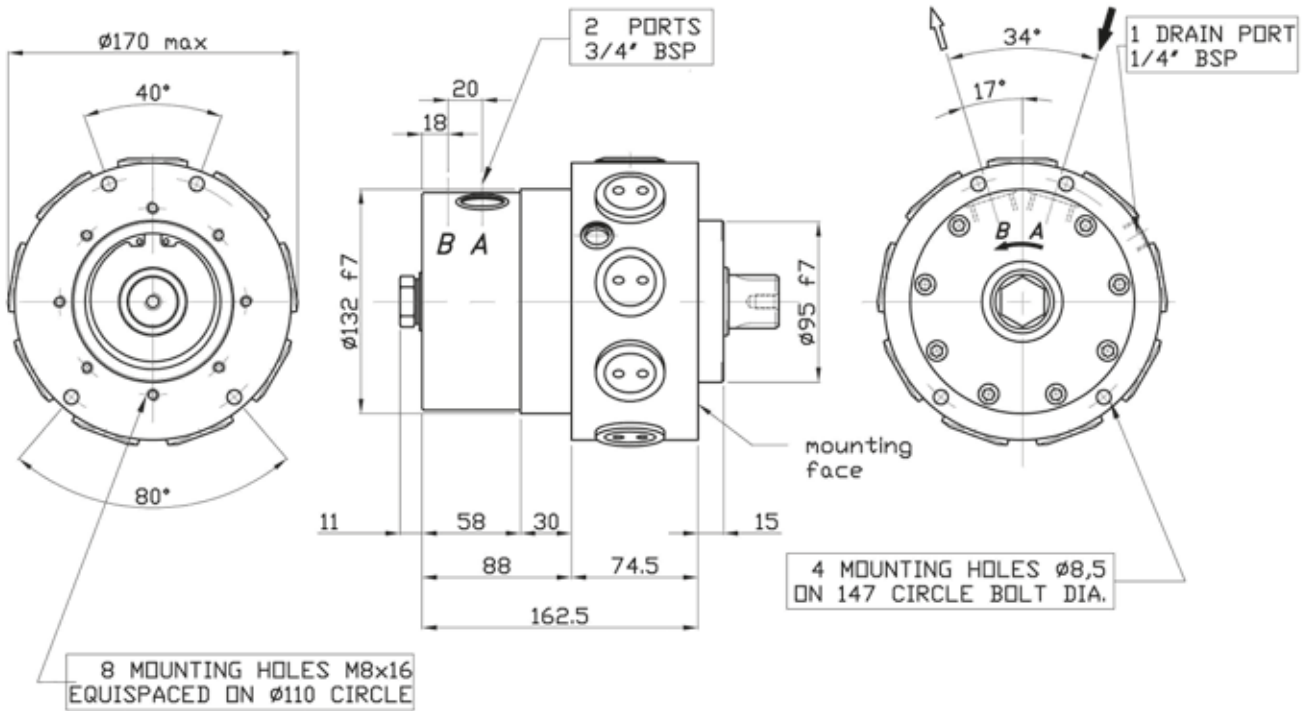

SHAFT

G 20-27-34

A0: Splined Shaft

A1: Splined Shaft

A2: Parallel shaft

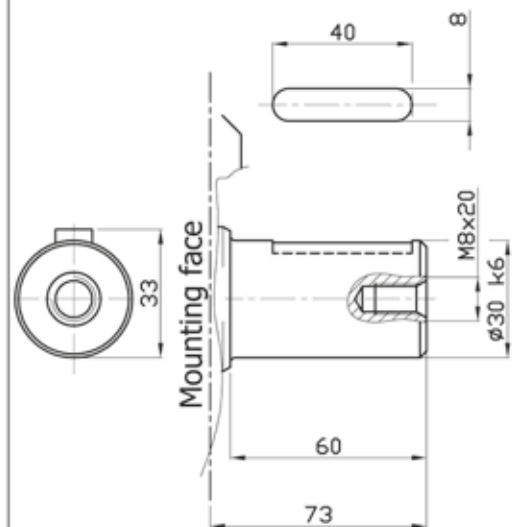
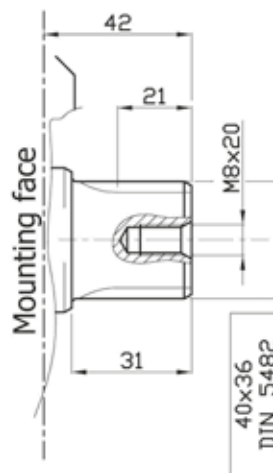
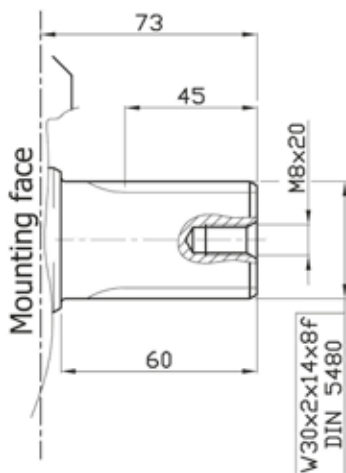

SIZE

G 50-75-90-100 SINGLE DISPLACEMENT

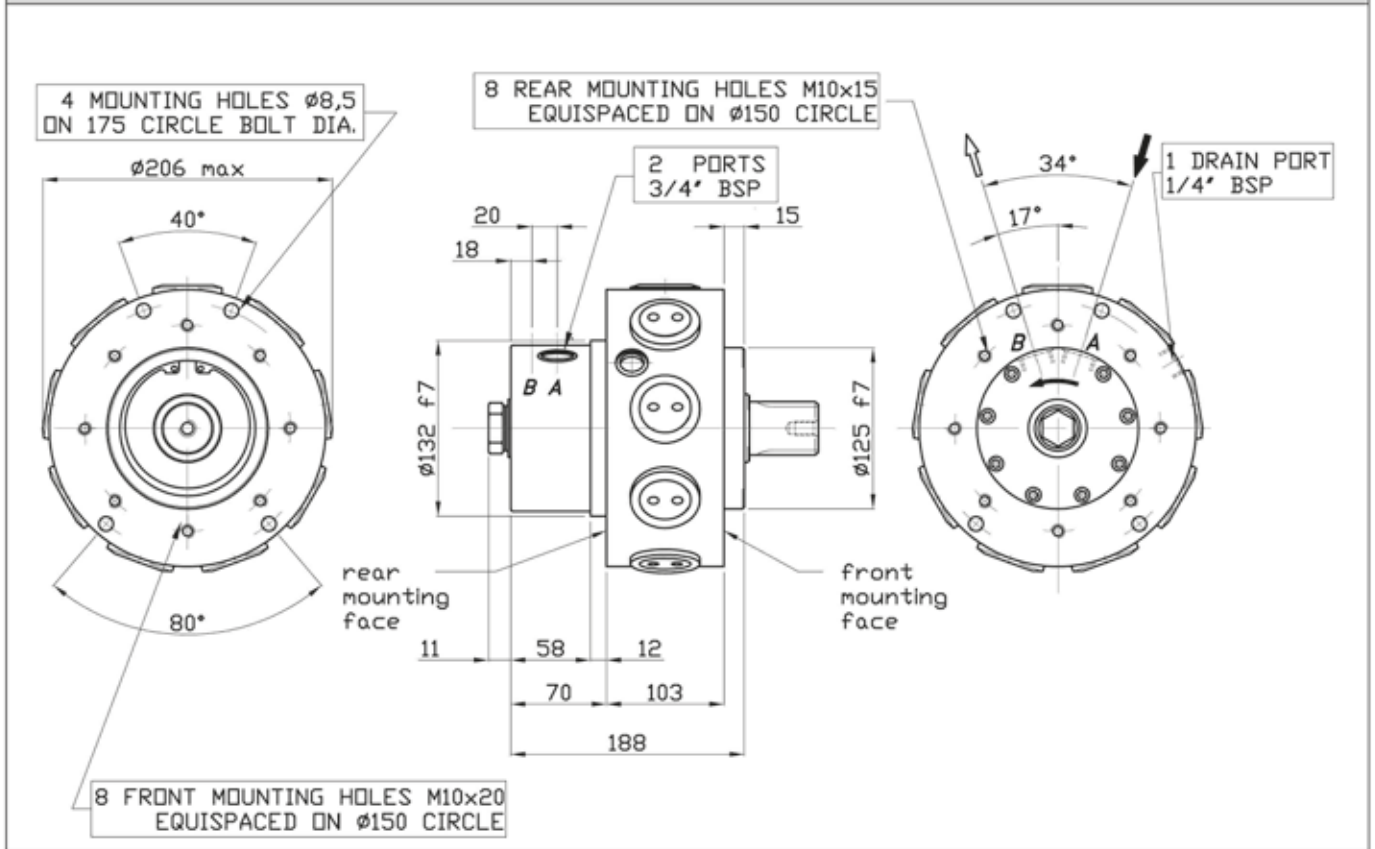

SHAFT

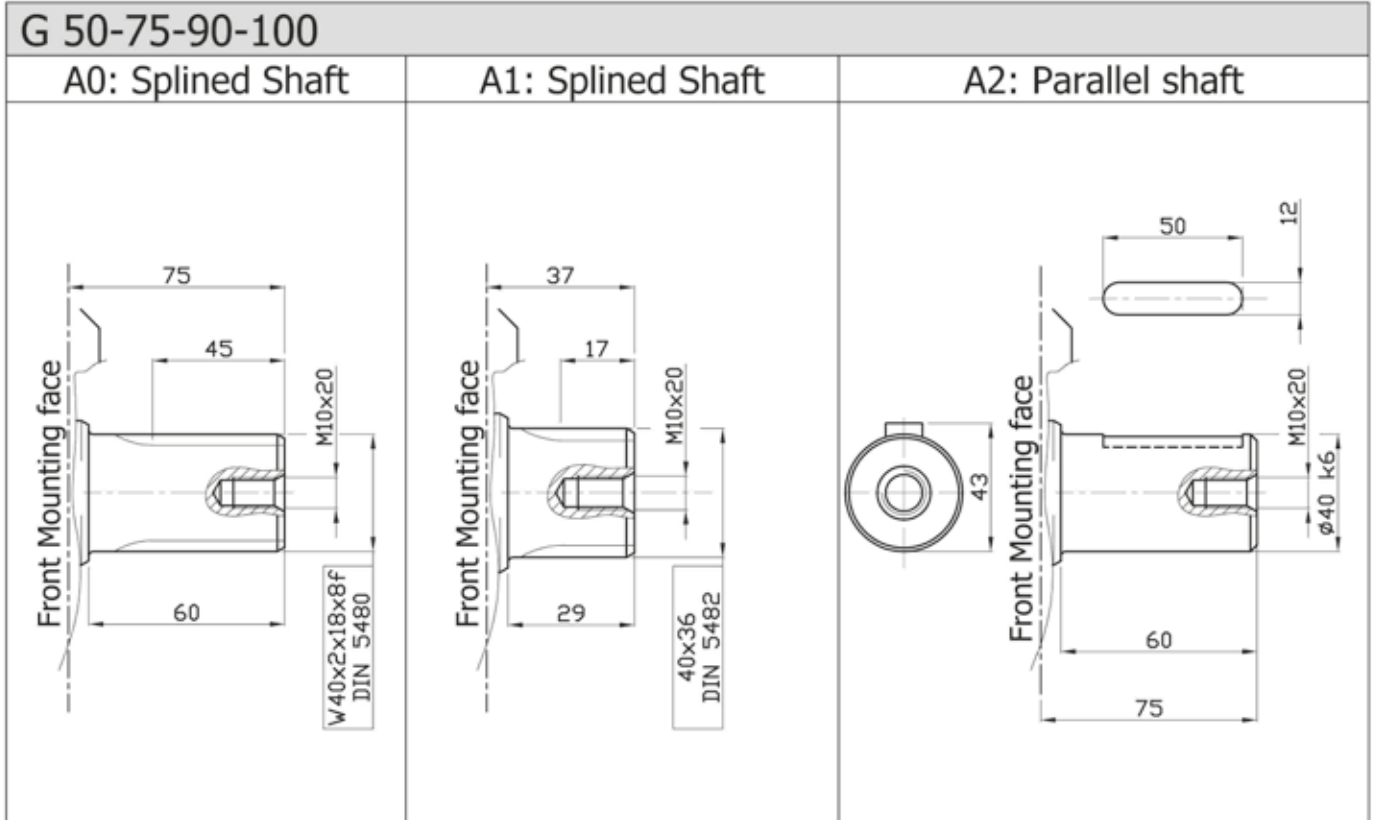

ORDERING INSTRUCTIONS

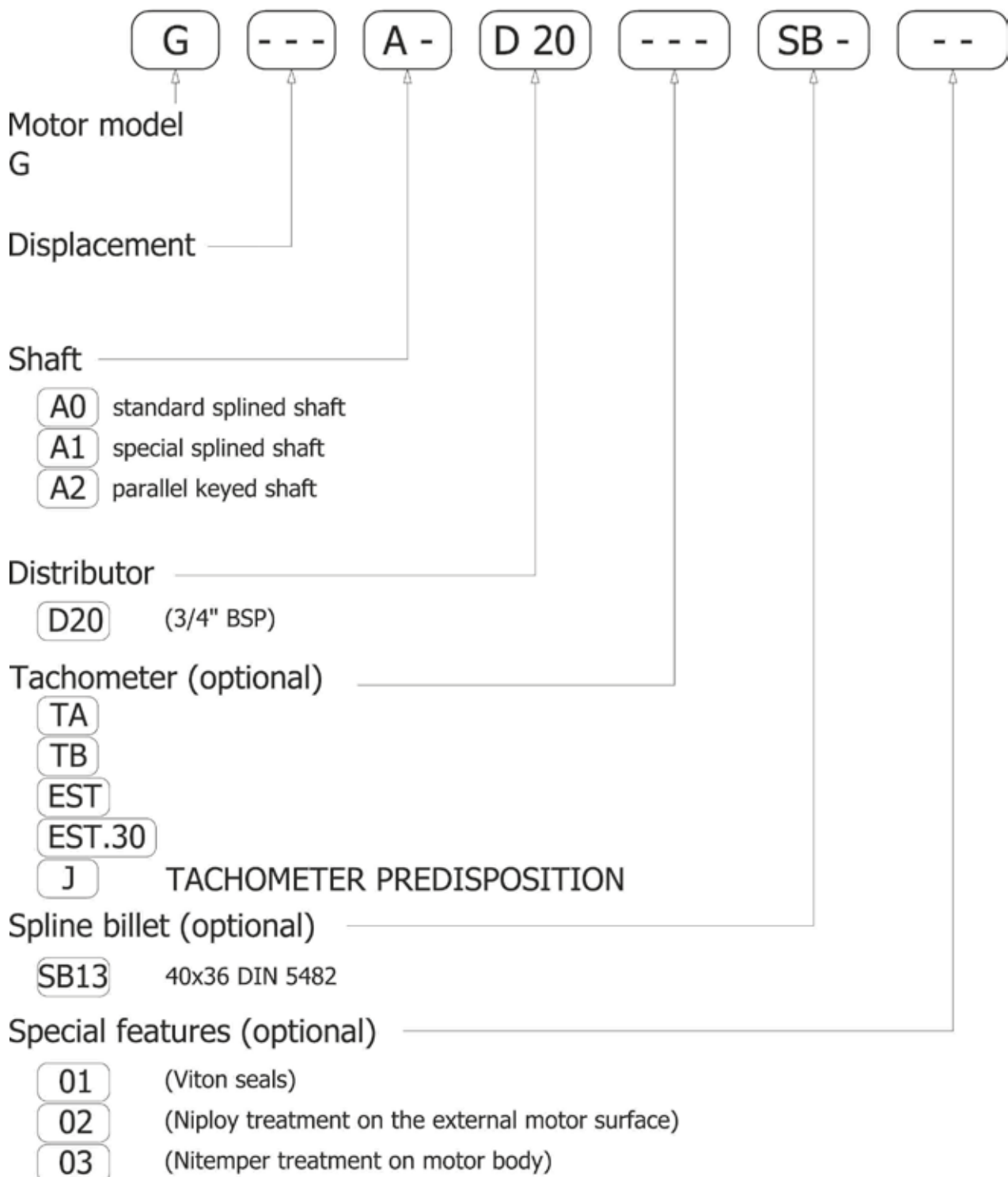

EXAMPLE: G.34.A1.D20.SB13.01
G.100.A0.D20.TA

TECHNICAL DATA

GD

DISPLACEMENT CHANGE DURING THE MOTOR FUNCTIONING

The user can choose between two displacements, acting on the hydraulic circuit. When the X port is at high pressure (system pressure) and the Y port is at low pressure (drain pressure), the motor functions at the maximum displacement, otherwise, when the Y port is at high pressure (system pressure) and the X port is at low pressure (drain pressure), the motor functions at the minimum displacement. When the X and Y ports are at low pressure the motor automatically switch in the maximum displacement. Please refer to "instruction and advice" section for the displacement change hydraulic circuit and to obtain more information.

DISPLACEMENTS SELECTION

Not all max and minimum displacements are possible, the displacements have a range, for the maximum displacement the customer can choose between 100 and 50 cc/Rev; for the minimum displacement the user can choose between 50 and 31 cc/Rev. In the following table are showed the technical data for some of the possible displacements.

| | | | | | |
|--------------------------------------|------|------|------|------|------|
| Max displacement [cc/Rev] | 100 | 89 | 76,3 | 63,6 | 50,3 |
| Specific theoretical torque [Nm/bar] | 1,61 | 1,41 | 1,21 | 1,01 | 0,81 |
| Maximum speed [rpm] | 1850 | 1900 | 2000 | 2100 | 2300 |
| Minimum speed [rpm] | 10 | 15 | 20 | 25 | 25 |
| Mechanical efficiency [%] | 89,5 | 89,2 | 89 | 88,5 | 88 |
| Starting mechanical efficiency [%] | 87 | 86 | 85 | 82 | 80 |
| Continuous maximum power [kW] | 48 | 42 | 35 | 31 | 25 |
| Maximum power [kW] | 60 | 52 | 44 | 39 | 31 |
| Continuous maximum pressure [bar] | 250 | 250 | 250 | 250 | 250 |
| Intermittent maximum pressure [bar] | 280 | 280 | 280 | 280 | 280 |
| Peak pressure [bar] | 350 | 350 | 350 | 350 | 350 |
| Dry weight | 25 | 25 | 25 | 25 | 25 |
| Recommended flushing flow [l/min] | 5 | 5 | 5 | 5 | 3 |

| | | | |
|--------------------------------------|------|------|------|
| Min displacement [cc/Rev] | 50,3 | 38 | 31 |
| Specific theoretical torque [Nm/bar] | 0,81 | 0,6 | 0,49 |
| Maximum speed [rpm] | 2300 | 2350 | 2400 |
| Minimum speed [rpm] | 25 | 30 | 30 |
| Mechanical efficiency [%] | 88 | 85 | 83 |
| Starting mechanical efficiency [%] | 80 | 75 | 45 |
| Continuous maximum power [kW] | 25 | 18 | 15 |
| Maximum power [kW] | 31 | 23 | 19 |
| Continuous maximum pressure [bar] | 250 | 250 | 250 |
| Intermittent maximum pressure [bar] | 280 | 280 | 280 |
| Peak pressure [bar] | 350 | 350 | 350 |
| Dry weight | 25 | 25 | 25 |
| Recommended flushing flow [l/min] | 3 | 3 | 3 |

When the motor continuously works at high power values, motor flushing is needed. The recommended flushing flow is shown in the above table. The values are approximated and must be always set in practice in order to guarantee a correct motor internal lubrication (please refer to page 8, flushing flow section). For closed loop circuit applications please contact ItalgrouP technical department.

For further information please contact ItalgrouP technical department.

SIZE

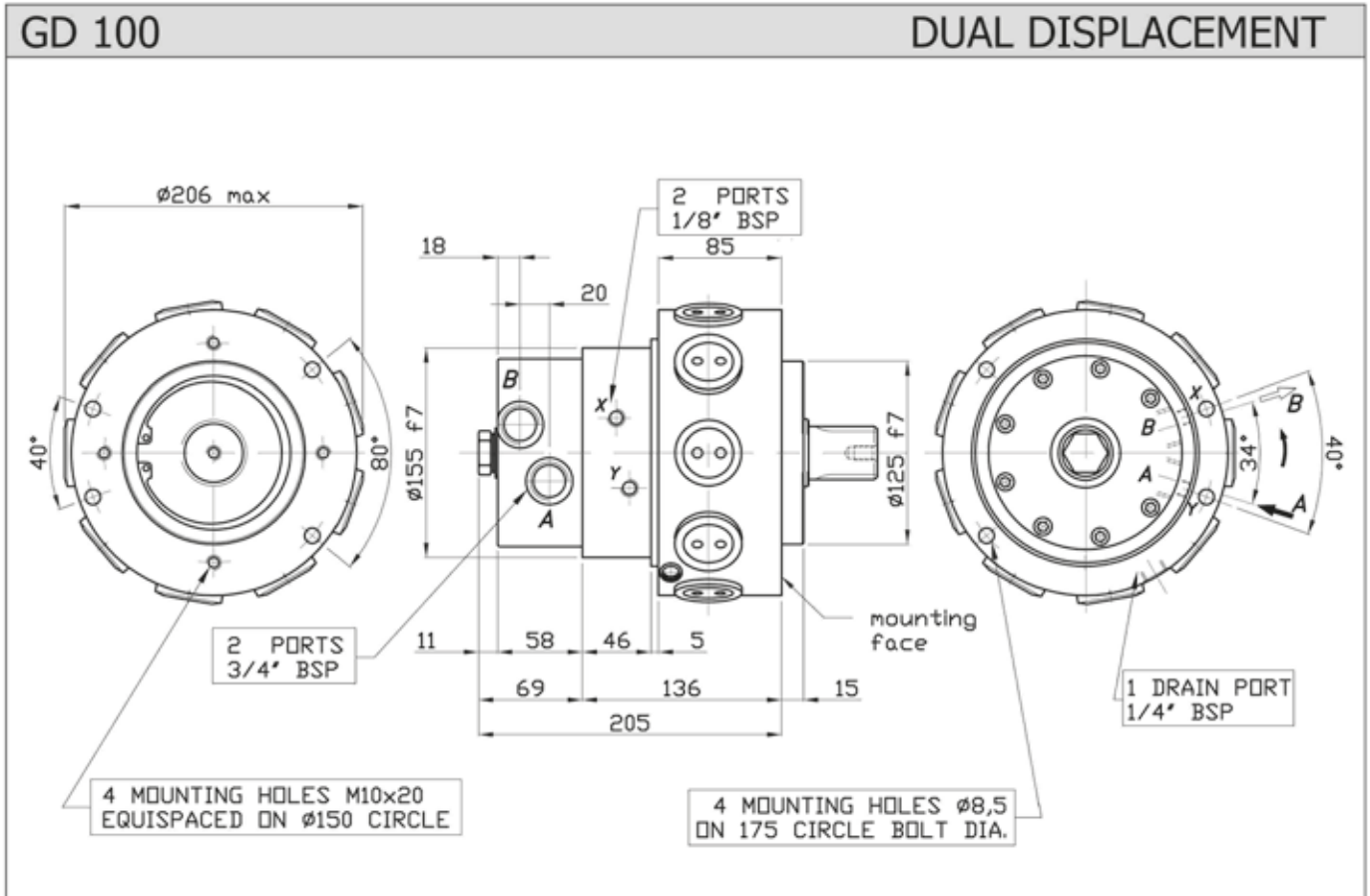

SHAFT

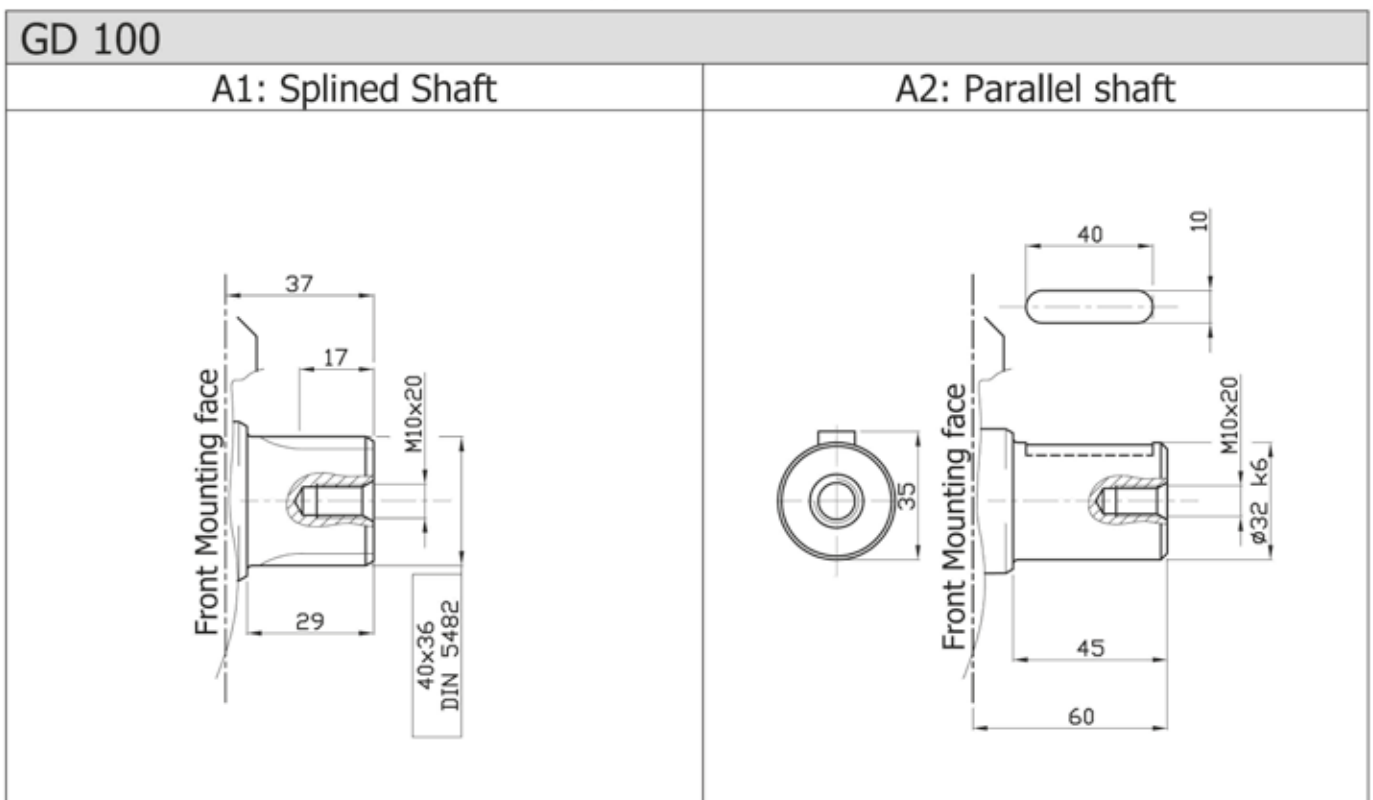

ORDERING INSTRUCTIONS

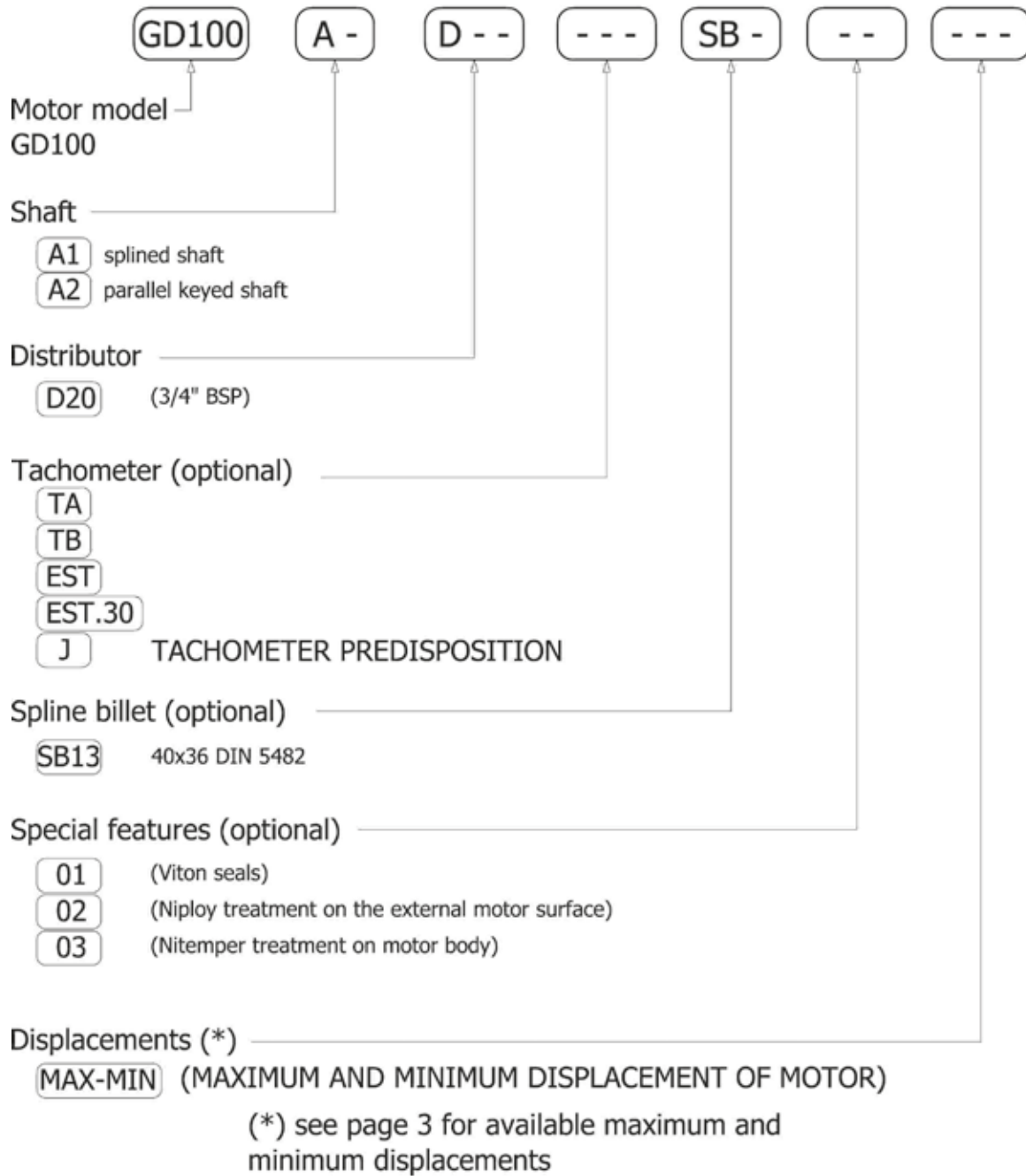

EXAMPLE: GD100.A1.D20.02.100-38
 GD100.A2.D20.TA.75-31
 GD100.A1.D20.J.60-38

TACHOMETER

TA

TB

EST

EST.30

| Operating parameters | E-..../3 |
|------------------------|-----------|
| Power supply (VDC) | 10-30 |
| Switching current (mA) | 150 |
| Frequency (Hz) 100rpm | 50 |
| Impulse/rpm | 30 |
| Operating temp. (°C) | -24/+70 |
| Protection degree | IP67 |
| Output | NPN |
| Motor type | All types |

| MODEL | Ø5 |
|--------|------|
| Torque | 1 Nm |

| Model | Output | Fig. |
|-----------------|--------|------|
| E-..../.AP/.... | PNP | D |

SPLINE BILLET

SB13

only for:
G 20-27-34-50-75-90-100 A1
GD 100 A1

CONTACT US

Italgroup S.r.l.
Via Pacinotti 20/22
41010 - Gaggio di Piano (Modena) – Italy

Tel. +39 059 92 42 57
Fax +39 059 92 01 13
e-mail: italgroup@italgroup.eu
internet: <http://www.italgroup.eu>

REACH US





ITALGROUP srl
VIA PACINOTTI, 20/22 - 41013 GAGGIO DI PIANO
CASTELFRANCO EMILIA - MODENA - ITALY
Tel. +39 059 924257 - Fax +39 059 920113
E-mail: italgroup@italgroup.eu
Web Site: www.italgroup.eu