

# MKE Synchronous Servomotors

ATEX ■ UKEX ■ CCC

## **Copyright**

© Bosch Rexroth AG 2021

All rights reserved, also regarding any disposal, exploitation, reproduction, editing, distribution, as well as in the event of applications for industrial property rights.

## **Liability**

The specified data is intended for product description purposes only and shall not be deemed to be a guaranteed characteristic unless expressly stipulated in the contract. All rights are reserved with respect to the content of this documentation and the availability of the product.

# Supplemental directives

Deutsch	English	Français
<p><b>▲ WARNUNG</b> Lebensgefahr bei Nichtbeachtung der nachstehenden Sicherheitshinweise!</p> <p>Nehmen Sie die Produkte erst dann in Betrieb, nachdem Sie die mit dem Produkt gelieferten Unterlagen und Sicherheitshinweise vollständig durchgelesen, verstanden und beachtet haben.</p> <p>Sollten Ihnen keine Unterlagen in Ihrer Landessprache vorliegen, wenden Sie sich an Ihren zuständigen Rexroth-Vertriebspartner.</p> <p>Nur qualifiziertes Personal darf an Antriebskomponenten arbeiten.</p> <p>Nähere Erläuterungen zu den Sicherheitshinweisen entnehmen Sie Kapitel 1 dieser Dokumentation.</p>	<p><b>▲ WARNING</b> Danger to life in case of non-compliance with the below-mentioned safety instructions!</p> <p>Do not attempt to install or put these products into operation until you have completely read, understood and observed the documents supplied with the product.</p> <p>If no documents in your language were supplied, please consult your Rexroth sales partner.</p> <p>Only qualified persons may work with drive components.</p> <p>For detailed explanations on the safety instructions, see chapter 1 of this documentation.</p>	<p><b>▲ AVERTISSEMENT</b> Danger de mort en cas de non-respect des consignes de sécurité figurant ci-après !</p> <p>Ne mettez les produits en service qu'après avoir lu complètement et après avoir compris et respecté les documents et les consignes de sécurité fournis avec le produit.</p> <p>Si vous ne disposez pas de la documentation dans votre langue, merci de consulter votre partenaire Rexroth.</p> <p>Seul un personnel qualifié est autorisé à travailler sur les composants d'entraînement.</p> <p>Vous trouverez des explications plus détaillées relatives aux consignes de sécurité au chapitre 1 de la présente documentation.</p>
<p><b>▲ WARNUNG</b> Hohe elektrische Spannung! Lebensgefahr durch elektrischen Schlag!</p> <p>Betreiben Sie Antriebskomponenten nur mit fest installiertem Schutzleiter.</p> <p>Schalten Sie vor Zugriff auf Antriebskomponenten die Spannungsversorgung aus.</p> <p>Beachten Sie die Entladezeiten von Kondensatoren.</p>	<p><b>▲ WARNING</b> High electrical voltage! Danger to life by electric shock!</p> <p>Only operate drive components with a permanently installed equipment grounding conductor.</p> <p>Disconnect the power supply before accessing drive components.</p> <p>Observe the discharge times of the capacitors.</p>	<p><b>▲ AVERTISSEMENT</b> Tensions électriques élevées ! Danger de mort par électrocution !</p> <p>N'exploitez les composants d'entraînement que si un conducteur de protection est installé de manière permanente.</p> <p>Avant d'intervenir sur les composants d'entraînement, coupez toujours la tension d'alimentation.</p> <p>Tenez compte des délais de décharge de condensateurs.</p>
<p><b>▲ WARNUNG</b> Gefährbringende Bewegungen! Lebensgefahr!</p> <p>Halten Sie sich nicht im Bewegungsbereich von Maschinen und Maschinenteilen auf.</p> <p>Verhindern Sie den unbeabsichtigten Zutritt für Personen.</p> <p>Bringen Sie vor dem Zugriff oder Zutritt in den Gefahrenbereich die Antriebe sicher zum Stillstand.</p>	<p><b>▲ WARNING</b> Dangerous movements! Danger to life!</p> <p>Keep free and clear of the ranges of motion of machines and moving machine parts.</p> <p>Prevent personnel from accidentally entering the range of motion of machines.</p> <p>Make sure that the drives are brought to safe standstill before accessing or entering the danger zone.</p>	<p><b>▲ AVERTISSEMENT</b> Mouvements entraînant une situation dangereuse ! Danger de mort !</p> <p>Ne séjournez pas dans la zone de mouvement de machines et de composants de machines.</p> <p>Évitez tout accès accidentel de personnes.</p> <p>Avant toute intervention ou tout accès dans la zone de danger, assurez-vous de l'arrêt préalable de tous les entraînements.</p>

Deutsch	English	Français
<p><b>▲WARNING</b> Elektromagnetische / magnetische Felder! Gesundheitsgefahr für Personen mit Herzschrittmachern, metallischen Implantaten oder Hörgeräten!</p> <p>Zutritt zu Bereichen, in denen Antriebskomponenten montiert und betrieben werden, ist für oben genannten Personen untersagt bzw. nur nach Rücksprache mit einem Arzt erlaubt.</p>	<p><b>▲WARNING</b> Electromagnetic / magnetic fields! Health hazard for persons with heart pacemakers, metal implants or hearing aids!</p> <p>The above-mentioned persons are not allowed to enter areas in which drive components are mounted and operated, or rather are only allowed to do this after they consulted a doctor.</p>	<p><b>▲AVERTISSEMENT</b> Champs électromagnétiques / magnétiques ! Risque pour la santé des porteurs de stimulateurs cardiaques, d'implants métalliques et d'appareils auditifs !</p> <p>L'accès aux zones où sont montés et exploités les composants d'entraînement est interdit aux personnes susmentionnées ou bien ne leur est autorisé qu'après consultation d'un médecin.</p>
<p><b>▲VORSICHT</b> Heiße Oberflächen (&gt; 60 °C)! Verbrennungsgefahr!</p> <p>Vermeiden Sie das Berühren von metallischen Oberflächen (z. B. Kühlkörpern). Abkühlzeit der Antriebskomponenten einhalten (mind. 15 Minuten).</p>	<p><b>▲CAUTION</b> Hot surfaces (&gt; 60 °C [140 °F])! Risk of burns!</p> <p>Do not touch metallic surfaces (e.g. heat sinks). Comply with the time required for the drive components to cool down (at least 15 minutes).</p>	<p><b>▲ATTENTION</b> Surfaces chaudes (&gt; 60 °C)! Risque de brûlure !</p> <p>Évitez de toucher des surfaces métalliques (p. ex. dissipateurs thermiques). Respectez le délai de refroidissement des composants d'entraînement (au moins 15 minutes).</p>
<p><b>▲VORSICHT</b> Unsachgemäße Handhabung bei Transport und Montage! Verletzungsgefahr!</p> <p>Verwenden Sie geeignete Montage- und Transporteinrichtungen.</p> <p>Benutzen Sie geeignetes Werkzeug und persönliche Schutzausrüstung.</p>	<p><b>▲CAUTION</b> Improper handling during transport and mounting! Risk of injury!</p> <p>Use suitable equipment for mounting and transport.</p> <p>Use suitable tools and personal protective equipment.</p>	<p><b>▲ATTENTION</b> Manipulation incorrecte lors du transport et du montage ! Risque de blessure !</p> <p>Utilisez des dispositifs de montage et de transport adéquats.</p> <p>Utilisez des outils appropriés et votre équipement de protection personnel.</p>
<p><b>▲VORSICHT</b> Unsachgemäße Handhabung von Batterien! Verletzungsgefahr!</p> <p>Versuchen Sie nicht, leere Batterien zu reaktivieren oder aufzuladen (Explosions- und Verletzungsgefahr).</p> <p>Zerlegen oder beschädigen Sie keine Batterien. Werfen Sie Batterien nicht ins Feuer.</p>	<p><b>▲CAUTION</b> Improper handling of batteries! Risk of injury!</p> <p>Do not attempt to reactivate or recharge low batteries (risk of explosion and chemical burns).</p> <p>Do not dismantle or damage batteries. Do not throw batteries into open flames.</p>	<p><b>▲ATTENTION</b> Manipulation incorrecte de piles! Risque de blessure!</p> <p>N'essayez pas de réactiver des piles vides ou de les charger (risque d'explosion et de brûlure par acide).</p> <p>Ne désassemblez et n'endommagez pas les piles. Ne jetez pas des piles dans le feu.</p>

Español	Português	Italiano
<p><b>▲ ADVERTENCIA</b> ¡Peligro de muerte en caso de no observar las siguientes indicaciones de seguridad!</p> <p>Los productos no se pueden poner en servicio hasta después de haber leído por completo, comprendido y tenido en cuenta la documentación y las advertencias de seguridad que se incluyen en la entrega.</p> <p>Si no dispusiera de documentación en el idioma de su país, diríjase a su distribuidor competente de Rexroth.</p> <p>Solo el personal debidamente cualificado puede trabajar en componentes de accionamiento.</p> <p>Encontrará más detalles sobre las indicaciones de seguridad en el capítulo 1 de esta documentación.</p>	<p><b>▲ ATENÇÃO</b> Perigo de vida em caso de inobservância das seguintes instruções de segurança!</p> <p>Utilize apenas os produtos depois de ter lido, compreendido e tomado em consideração a documentação e as instruções de segurança fornecidas juntamente com o produto.</p> <p>Se não tiver disponível a documentação na sua língua, dirija-se ao seu parceiro de venda responsável da Rexroth.</p> <p>Apenas pessoal qualificado pode trabalhar nos componentes de acionamento.</p> <p>Explicações mais detalhadas relativamente às instruções de segurança constam no capítulo 1 desta documentação.</p>	<p><b>▲ AVVERTENZA</b> Pericolo di morte in caso di inosservanza delle seguenti indicazioni di sicurezza!</p> <p>Mettere in funzione i prodotti solo dopo aver letto, compreso e osservato per intero la documentazione e le indicazioni di sicurezza fornite con il prodotto.</p> <p>Se non dovesse essere presente la documentazione nella vostra lingua, siete pregati di rivolgervi al rivenditore Rexroth competente.</p> <p>Solo personale qualificato può eseguire lavori sui componenti di comando.</p> <p>Per ulteriori spiegazioni riguardanti le indicazioni di sicurezza consultare il capitolo 1 di questa documentazione.</p>
<p><b>▲ ADVERTENCIA</b> ¡Alta tensión eléctrica! ¡Peligro de muerte por descarga eléctrica!</p> <p>Active sólo los componentes de accionamiento con el conductor protector firmemente instalado.</p> <p>Desconecte la alimentación eléctrica antes de manipular los componentes de accionamiento.</p> <p>Tenga en cuenta los tiempos de descarga de los condensadores.</p>	<p><b>▲ ATENÇÃO</b> Alta tensão elétrica! Perigo de vida devido a choque elétrico!</p> <p>Opere componentes de accionamento apenas com condutores de proteção instalados.</p> <p>Desligue a alimentação de tensão antes de aceder aos componentes de accionamento.</p> <p>Respeite os períodos de descarga dos condensadores.</p>	<p><b>▲ AVVERTENZA</b> Alta tensione elettrica! Pericolo di morte in seguito a scosse elettriche!</p> <p>Mettere in esercizio i componenti di comando solo con conduttore di messa a terra ben installato.</p> <p>Staccare l'alimentazione prima di intervenire sui componenti di comando.</p> <p>Osservare i tempi di scarica del condensatore.</p>
<p><b>▲ ADVERTENCIA</b> ¡Movimientos peligrosos! ¡Peligro de muerte!</p> <p>No permanezca en la zona de movimiento de las máquinas ni de sus piezas.</p> <p>Impida el acceso accidental de personas.</p> <p>Antes de acceder o introducir las manos en la zona de peligro, los accionamientos se tienen que haber parado con seguridad.</p>	<p><b>▲ ATENÇÃO</b> Movimentos perigosos! Perigo de vida!</p> <p>Não permaneça na área de movimentação das máquinas e das peças das máquinas.</p> <p>Evite o acesso involuntário para pessoas.</p> <p>Antes de entrar ou aceder à área perigosa, imobilize os accionamentos de forma segura.</p>	<p><b>▲ AVVERTENZA</b> Movimenti pericolosi! Pericolo di morte!</p> <p>Non sostare nelle zone di manovra delle macchine e delle loro parti.</p> <p>Impedire un accesso non autorizzato per le persone.</p> <p>Prima di accedere alla zona di pericolo, arrestare e bloccare gli azionamenti.</p>
<p><b>▲ ADVERTENCIA</b> ¡Campos electromagnéticos/magnéticos! ¡Peligro para la salud de las personas con marcapasos, implantes metálicos o audífonos!</p> <p>El acceso de las personas arriba mencionadas a las zonas de montaje o funcionamiento de los componentes de accionamiento está prohibido, salvo que lo autorice previamente un médico.</p>	<p><b>▲ ATENÇÃO</b> Campos eletromagnéticos / magnéticos! Perigo de saúde para pessoas com marcapassos, implantes metálicos ou aparelhos auditivos!</p> <p>Acesso às áreas, nas quais os componentes de accionamento são montados e operados, é proibido para as pessoas em cima mencionadas ou apenas após permissão de um médico.</p>	<p><b>▲ AVVERTENZA</b> Campi elettromagnetici / magnetici! Pericolo per la salute delle persone portatrici di pacemaker, protesi metalliche o apparecchi acustici!</p> <p>L'accesso alle zone in cui sono installati o in funzione componenti di comando è vietato per le persone sopra citate o consentito solo dopo un colloquio con il medico.</p>

Español	Português	Italiano
<p><b>⚠ ATENCIÓN</b> ¡Superficies calientes (&gt; 60 °C)!  <b>¡Peligro de quemaduras!</b></p> <p>Evite el contacto con las superficies calientes (p. ej., disipadores de calor). Observe el tiempo de enfriamiento de los componentes de accionamiento (mín. 15 minutos).</p>	<p><b>⚠ CUIDADO</b> Superfícies quentes (&gt; 60 °C)!  <b>Perigo de queimaduras!</b></p> <p>Evite tocar superfícies metálicas (p. ex. radiadores). Respeite o tempo de arrefecimento dos componentes de accionamento (mín. 15 minutos).</p>	<p><b>⚠ ATTENZIONE</b> Superfici bollenti (&gt; 60 °C)!  <b>Pericolo di ustioni!</b></p> <p>Evitare il contatto con superfici metalliche (ad es. dissipatori di calore). Rispettare i tempi di raffreddamento dei componenti di comando (almeno 15 minuti).</p>
<p><b>⚠ ATENCIÓN</b> ¡Manipulación inadecuada en el transporte y montaje! <b>¡Peligro de lesiones!</b></p> <p>Utilice dispositivos de montaje y de transporte adecuados.</p> <p>Utilice herramientas adecuadas y equipo de protección personal.</p>	<p><b>⚠ CUIDADO</b> Manejo incorreto no transporte e montagem! <b>Perigo de ferimentos!</b></p> <p>Utilize dispositivos de montagem e de transporte adequados.</p> <p>Utilize ferramentas e equipamento de proteção individual adequados.</p>	<p><b>⚠ ATTENZIONE</b> Manipolazione inappropriata durante il trasporto e il montaggio! <b>Pericolo di lesioni!</b></p> <p>Utilizzare dispositivi di montaggio e trasporto adatti.</p> <p>Utilizzare attrezzi adatti ed equipaggiamento di protezione personale.</p>
<p><b>⚠ ATENCIÓN</b> ¡Manejo inadecuado de las pilas!  <b>¡Peligro de lesiones!</b></p> <p>No trate de reactivar o cargar pilas descargadas (peligro de explosión y cauterización).</p> <p>No desarme ni dañe las pilas. No tire las pilas al fuego.</p>	<p><b>⚠ CUIDADO</b> Manejo incorreto de baterias!  <b>Perigo de ferimentos!</b></p> <p>Não tente reativar nem carregar baterias vazias (perigo de explosão e de queimaduras com ácido).</p> <p>Não desmonte nem danifique as baterias. Não deite as baterias no fogo.</p>	<p><b>⚠ ATTENZIONE</b> Utilizzo inappropriato delle batterie! <b>Pericolo di lesioni!</b></p> <p>Non tentare di riattivare o ricaricare batterie scariche (pericolo di esplosione e corrosione).</p> <p>Non scomporre o danneggiare le batterie. Non gettare le batterie nel fuoco.</p>

Svenska	Dansk	Nederlands
<p><b>⚠ VARNING</b> Livsfara om följande säkerhetsanvisningar inte följs!</p> <p>Använd inte produkterna innan du har läst och förstått den dokumentation och de säkerhetsanvisningar som medföljer produkten, och följ alla anvisningar.</p> <p>Kontakta din Rexroth-återförsäljare om dokumentationen inte medföljer på ditt språk.</p> <p>Endast kvalificerad personal får arbeta med drivkomponenterna.</p> <p>Se kapitel 1 i denna dokumentation för närmare beskrivningar av säkerhetsanvisningarna.</p>	<p><b>⚠ ADVARSEL</b> Livsfare ved manglende overholdelse af nedenstående sikkerhedsanvisninger!</p> <p>Tag ikke produktet i brug, før du har læst og forstået den dokumentation og de sikkerhedsanvisninger, som følger med produktet, og overhold de givne anvisninger.</p> <p>Kontakt din Rexroth-forhandler, hvis dokumentationen ikke medfølger på dit sprog.</p> <p>Det er kun kvalificeret personale, der må arbejde på drive componenter.</p> <p>Nærmere forklaringer til sikkerhedsanvisningerne fremgår af kapitel 1 i denne dokumentation.</p>	<p><b>⚠ WAARSCHUWING</b> Levensgevaar bij niet-naleving van onderstaande veiligheidsinstructies!</p> <p>Stel de producten pas in bedrijf nadat u de met het product geleverde documenten en de veiligheidsinformatie volledig gelezen, begrepen en in acht genomen heeft.</p> <p>Mocht u niet beschikken over documenten in uw landstaal, kunt u contact opnemen met uw plaatselijke Rexroth distributiepartner.</p> <p>Uitsluitend gekwalificeerd personeel mag aan de aandrijvingscomponenten werken.</p> <p>Meer informatie over de veiligheidsinstructies vindt u in hoofdstuk 1 van deze documentatie.</p>

Svenska	Dansk	Nederlands
<p><b>▲ VARNING</b> Hög elektrisk spänning! Livsfara genom elchock!</p> <p>Använd endast drivkomponenterna med fast-monterad skyddsledare.</p> <p>Koppla bort spänningsförsörjningen före arbete på drivkomponenter.</p> <p>Var medveten om kondensatorernas urladdningstid.</p>	<p><b>▲ ADVARSEL</b> Elektrisk højspænding! Livsfare på grund af elektrisk stød!</p> <p>Drive components må kun benyttes med et fast installeret jordstik.</p> <p>Sørg for at koble spændingsforsyningen fra, inden du rører ved drive components.</p> <p>Overhold kondensatorernes afladningstider.</p>	<p><b>▲ WAARSCHUWING</b> Hoge elektrische spanning! Levensgevaar door elektrische schok!</p> <p>Bedien de aandrijvingscomponenten uitsluitend met vast geïnstalleerde aardleiding.</p> <p>Schakel voor toegang tot aandrijvingscomponenten de spanningsvoorziening uit.</p> <p>Neem de ontladtid van de condensatoren in acht.</p>
<p><b>▲ VARNING</b> Farliga rörelser! Livsfara!</p> <p>Uppehåll dig inte inom maskiners och maskinernas rörelseområde.</p> <p>Förhindra att obehöriga personer får tillträde.</p> <p>Innan du börjar arbeta eller vistas inom drivsystemets riskområde måste maskinen vara stillastående.</p>	<p><b>▲ ADVARSEL</b> Farlige bevægelser! Livsfare!</p> <p>Du må ikke opholde dig inden for maskiners og maskindeles bevægelsesradius.</p> <p>Sørg for, at ingen personer kan få utilsigtet adgang.</p> <p>Stands drevene helt, inden du rører ved drevene eller træder ind i deres fareområde.</p>	<p><b>▲ WAARSCHUWING</b> Risicovolle bewegingen! Levensgevaar!</p> <p>Houdt u niet op in het bewegingsbereik van machines en machineonderdelen.</p> <p>Voorkom dat personen onbedoeld toegang verkrijgen.</p> <p>Voor toegang tot de gevaarlijke zone moeten de aandrijvingen veilig tot stilstand gebracht zijn.</p>
<p><b>▲ VARNING</b> Elektromagnetiska/magnetiska fält! Hälssofaror för personer med pacemaker, implantat av metall eller hörapparat!</p> <p>Det är förbjudet för ovan nämnda personer (eller kräver överläggning med läkare) att beträda områden där drivkomponenter är monterade och i drift.</p>	<p><b>▲ ADVARSEL</b> Elektromagnetiske/magnetiske felter! Sundhedsfare for personer med pacemakere, metalliske implantater eller høreapparater!</p> <p>For disse personer er der adgang forbudt eller kun adgang med tilladelse fra læge til de områder, hvor drive components monteres og drives.</p>	<p><b>▲ WAARSCHUWING</b> Elektromagnetische / magnetische velden! Gevaar voor de gezondheid van personen met pacemakers, metalen implantaten of hoorapparaten!</p> <p>Toegang tot gebieden, waarin aandrijvingscomponenten worden gemonteerd en bediend, is verboden voor voornoemde personen of uitsluitend toegestaan na overleg met een arts.</p>
<p><b>▲ OBSERVERA</b> Varma ytor (&gt; 60 °C)! Risk för brännskador!</p> <p>Undvik att vidröra metalltytor (t.ex. kylelement). Var medveten om att det tar tid för drivkomponenterna att svalna (minst 15 minuter).</p>	<p><b>▲ FORSIGTIG</b> Varme overflader (&gt; 60 °C)! Risiko for forbrændinger!</p> <p>Undgå at berøre metaloverflader (f.eks. køleelementer). Overhold drive components nedkølingstid (min. 15 min.).</p>	<p><b>▲ VOORZICHTIG</b> Hete oppervlakken (&gt; 60 °C)! Verbrandingsgevaar!</p> <p>Voorkom contact met metalen oppervlakken (bijv. Koellichamen). Afkoeltijd van de aandrijvingscomponenten in acht nemen (min. 15 minuten).</p>
<p><b>▲ OBSERVERA</b> Felaktig hantering vid transport och montering! Skaderisk!</p> <p>Använd passande monterings- och transportanordningar.</p> <p>Använd lämpliga verktyg och personlig skyddsutrustning.</p>	<p><b>▲ FORSIGTIG</b> Fejlhåndtering ved transport og montering! Risiko for kvæstelser!</p> <p>Benyt egnede monterings- og transportanordninger.</p> <p>Benyt egnet værktøj og personligt sikkerhedsudstyr.</p>	<p><b>▲ VOORZICHTIG</b> Onjuist gebruik bij transport en montage! Letselgevaar!</p> <p>Gebruik geschikte montage- en transportinrichtingen.</p> <p>Gebruik geschikt gereedschap en een persoonlijke veiligheidsuitrusting.</p>

Svenska	Dansk	Nederlands
<p><b>▲ OBSERVERA</b> Felaktigt hantering av batterier! Skaderisk!</p> <p>Försök inte återaktivera eller ladda upp batterier (risk för explosioner och frätskador).</p> <p>Batterierna får inte tas isär eller skadas. Släng inte batterierna i elden.</p>	<p><b>▲ FORSIGTIG</b> Fejlhåndtering af batterier! Risiko for kvæstelser!</p> <p>Forsøg ikke at genaktivere eller oplade tomme batterier (eksplosions- og ætsningsfare).</p> <p>Undlad at skille batterier ad eller at beskadige dem. Smid ikke batterier ind i åben ild.</p>	<p><b>▲ VOORZICHTIG</b> Onjuist gebruik van batterijen! Letselgevaar!</p> <p>Probeer nooit lege batterijen te reactiveren of op te laden (explosiegevaar en gevaar voor beschadiging van weefsel door cauterisatie).</p> <p>Batterijen niet demonteren of beschadigen. Nooit batterijen in het vuur werpen.</p>
Suomi	Polski	Český
<p><b>▲VAROITUS</b> Näiden turvaohjeiden noudattamatta jättämisestä on seurauksena hengenvaara!</p> <p>Ota tuote käyttöön vasta sen jälkeen, kun olet lukenut läpi tuotteen mukana toimitetut asiakirjat ja turvallisuusohjeet, ymmärtänyt ne ja ottanut ne huomioon.</p> <p>Jos asiakirjoja ei ole saatavana omalla äidinkielläsi, ota yhteys asianomaiseen Rexrothin myyntiedustajaan.</p> <p>Käyttölaitteiden komponenttien parissa saa työskennellä ainoastaan valtuutettu henkilöstö.</p> <p>Lisätietoa turvaohjeista löydät tämän dokumentaation luvusta 1.</p>	<p><b>▲ OSTRZEŻENIE</b> Zagrożenie życia w razie nieprzestrzegania poniższych wskazówek bezpieczeństwa!</p> <p>Nie uruchamiać produktów przed uprzednim przeczytaniem i pełnym zrozumieniem wszystkich dokumentów dostarczonych wraz z produktem oraz wskazówek bezpieczeństwa.</p> <p>Należy przestrzegać wszystkich zawartych tam zaleceń.</p> <p>W przypadku braku dokumentów w Państwa języku, prosimy o skontaktowanie się z lokalnym partnerem handlowym Rexroth.</p> <p>Przy zespołach napędowych może pracować wyłącznie wykwalifikowany personel.</p> <p>Blizsze objaśnienia wskazówek bezpieczeństwa znajdują się w Rozdziale 1 niniejszej dokumentacji.</p>	<p><b>▲VAROVÁNÍ</b> Nebezpečí života v případě nedodržení níže uvedených bezpečnostních pokynů!</p> <p>Před uvedením výrobků do provozu si přečtěte kompletní dokumentaci a bezpečnostní pokyny dodávané s výrobkem, pochopte je a dodržujte.</p> <p>Nemáte-li k dispozici podklady ve svém jazyce, obraťte se na příslušného obchodního partnera Rexroth.</p> <p>Na komponentách pohonu smí pracovat pouze kvalifikovaný personál.</p> <p>Podrobnější vysvětlení k bezpečnostním pokynům naleznete v kapitole 1 této dokumentace.</p>
<p><b>▲VAROITUS</b> Voimakas sähköjännite! Sähköiskun aiheuttama hengenvaara!</p> <p>Käytä käyttölaitteen komponentteja ainoastaan maadoitusohjeen ollessa kiinteästi asennettuna.</p> <p>Katkaise jännitteensyöttö ennen käyttölaitteen komponenteille suoritettavien töiden aloittamista.</p> <p>Huomioi kondensaattoreiden purkausajat.</p>	<p><b>▲ OSTRZEŻENIE</b> Wysokie napięcie elektryczne! Zagrożenie życia w wyniku porażenia prądem!</p> <p>Zespoły napędu mogą być eksploatowane wyłącznie z zainstalowanym na stałe przewodem ochronnym.</p> <p>Przed uzyskaniem dostępu do podzespołów napędu należy odłączyć zasilanie elektryczne.</p> <p>Zwracać uwagę na czas rozładowania kondensatorów.</p>	<p><b>▲VAROVÁNÍ</b> Vysoké elektrické napětí! Nebezpečí života při zasažení elektrickým proudem!</p> <p>Komponenty pohonu smí být v provozu pouze s pevně nainstalovaným ochranným vodičem.</p> <p>Než začnete zasahovat do komponent pohonu, odpojte je od elektrického napájení.</p> <p>Dodržujte vybijecí časy kondenzátorů.</p>

Suomi	Polski	Český
<p><b>▲VAROITUS</b> Vaarallisia liikkeitä! Hengen vaara!</p> <p>Älä oleskele koneiden tai koneenosien liikealueella.</p> <p>Pidä huolta siitä, ettei muita henkilöitä pääse alueelle vahingossa.</p> <p>Pysäytä käyttölaitteet varmasti ennen vaara-alueelle koskemista tai menemistä.</p>	<p><b>▲OSTRZEŻENIE</b> Niebezpieczne ruchy! Zagrożenie życia!</p> <p>Nie wolno przebywać w obszarze pracy maszyny i jej elementów.</p> <p>Nie dopuszczać osób niepowołanych do obszaru pracy maszyny.</p> <p>Przed dotknięciem urządzenia/maszyny lub zbliżeniem się do obszaru zagrożenia należy zgodnie z zasadami bezpieczeństwa wyłączyć napędy.</p>	<p><b>▲VAROVÁNÍ</b> Nebezpečné pohyby! Nebezpečí života!</p> <p>Nezdržujte se v dosahu pohybu strojů a jejich součástí.</p> <p>Zabraňte náhodnému přístupu osob.</p> <p>Před zásahem nebo vstupem do nebezpečného prostoru bezpečně zastavte pohony.</p>
<p><b>▲VAROITUS</b> Sähkömagneettisia/magneettisia kenttiä! Terveystieteiden haavoittumisen vaara henkilöille, joilla on sydämentahdistin, metallinen implantti tai kuulolaite!</p> <p>Yllä mainituilta henkilöiltä on pääsy kielletty alueille, joilla asennetaan tai käytetään käyttölaitteen komponentteja, tai heidän on ensin saatava tähän suostumus lääkäriltään.</p>	<p><b>▲OSTRZEŻENIE</b> Pola elektromagnetyczne / magnetyczne! Zagrożenie zdrowia dla osób z rozrusznikiem serca, metalowymi implantami lub aparatami słuchowymi!</p> <p>Wstęp na teren, gdzie odbywa się montaż i eksploatacja napędów jest dla ww. osób zabroniony względnie dozwolony po konsultacji z lekarzem.</p>	<p><b>▲VAROVÁNÍ</b> Elektromagnetická/magnetická pole! Nebezpečí pro zdraví osob s kardiostimulátory, kovovými implantáty nebo naslouchadly!</p> <p>Výše uvedené osoby mají zakázán přístup do prostorů, kde jsou montovány a používány komponenty pohonu, resp. ho mají povolen pouze po poradě s lékařem.</p>
<p><b>▲HUOMIO</b> Kuumia pintoja (&gt; 60 °C)! Palovammojen vaara!</p> <p>Vältä metallipintojen koskettamista (esim. jäähdytyslevyt). Noudata käyttölaitteen komponenttien jäähtymisaikojia (väh. 15 minuuttia).</p>	<p><b>▲PRZESTROGA</b> Gorące powierzchnie (&gt; 60 °C)! Niebezpieczeństwo poparzenia!</p> <p>Unikać kontaktu z powierzchniami metalowymi (np. radiatorami). Przestrzegać czasów schładzania podzespołów napędów (min. 15 minut).</p>	<p><b>▲UPOZORNĚNÍ</b> Horké povrchy (&gt; 60 °C)! Nebezpečí popálení!</p> <p>Nedotýkejte se kovových povrchů (např. chladičích těles). Dodržujte dobu ochlazení komponent pohonu (min. 15 minut).</p>
<p><b>▲HUOMIO</b> Epäasianmukainen käsittely kuljetuksen ja asennuksen yhteydessä! Loukkaantumisvaara!</p> <p>Käytä soveltuvia asennus- ja kuljetuslaitteita.</p> <p>Käytä omia työkaluja ja henkilökohtaisia suojavarusteita.</p>	<p><b>▲PRZESTROGA</b> Niewłaściwe obchodzenie się podczas transportu i montażu! Ryzyko urazu!</p> <p>Stosować odpowiednie urządzenia montażowe i transportowe.</p> <p>Stosować odpowiednie narzędzia i środki ochrony osobistej.</p>	<p><b>▲UPOZORNĚNÍ</b> Nesprávné zacházení při přepravě a montáži! Nebezpečí zranění!</p> <p>Používejte vhodná montážní a dopravní zařízení.</p> <p>Používejte vhodné nářadí a osobní ochranné vybavení.</p>
<p><b>▲HUOMIO</b> Paristojen epäasianmukainen käsittely! Loukkaantumisvaara!</p> <p>Älä yritä saada tyhjiä paristoja toimimaan tai ladata niitä uudelleen (räjähdys- ja syöpymisvaara).</p> <p>Älä hajota paristoja osiin tai vaurioita niitä. Älä heitä paristoja tuleen.</p>	<p><b>▲PRZESTROGA</b> Niewłaściwe obchodzenie się z bateriami! Ryzyko urazu!</p> <p>Nie próbować reaktywować i nie ładować zużytych baterii (niebezpieczeństwo wybuchu oraz poparzenia żrącą substancją).</p> <p>Nie demontować i nie niszczyć baterii. Nie wrzucać baterii do ognia.</p>	<p><b>▲UPOZORNĚNÍ</b> Nesprávné zacházení s bateriemi! Nebezpečí zranění!</p> <p>Nepokoušejte se znovu aktivovat nebo dobíjet prázdné baterie (nebezpečí výbuchu a poleptání).</p> <p>Nerozebírejte ani nepoškozujte baterie. Neházejte baterie do ohně.</p>

Slovensko	Slovenčina	Română
<p><b>▲ OPOZORILO</b> Življenska nevarnost pri neupoštevanju naslednjih napotkov za varnost!</p> <p>Izdelke začnite uporabljati šele, ko v celoti preberete, razumete in upoštevate izdelkom priloženo dokumentacijo in varnostne napotke.</p> <p>Če priložena dokumentacija ni na voljo v vašem maternem jeziku, se obrnite na pristojnega distributerja Rexroth.</p> <p>Samo kvalificirano osebje sme delati na pogonskih komponentah.</p> <p>Podrobnejša pojasnila o varnostnih navodilih najdete v poglavju 1 v tej dokumentaciji.</p>	<p><b>▲ VAROVANIE</b> Nebezpečnostv ohrozenia života pri nedodržavaní nasledujúcich bezpečnostných pokynov!</p> <p>Výrobky uvádzajte do prevádzky až potom, čo ste úplne prečítali, pochopili a zobrali do úvahy podklady a bezpečnostné pokyny dodané s výrobkom.</p> <p>Ak by ste nemali k dispozícii žiadne podklady v jazyku svojej krajiny, obráťte sa prosím na svojho príslušného predajcu Rexroth.</p> <p>Na komponentoch pohonu smie pracovať iba kvalifikovaný personál.</p> <p>Bližšie vysvetlenia k bezpečnostným pokynom zistíte z kapitoly 1 tejto dokumentácie.</p>	<p><b>▲ AVERTIZARE</b> Pericol de moarte în cazul nespectării următoarelor instrucțiuni de siguranță!</p> <p>Punerea în funcțiune a produselor trebuie efectuată după citirea, înțelegerea și respectarea documentelor și instrucțiunilor de siguranță, care sunt livrate împreună cu produsele.</p> <p>În cazul în care documentele nu sunt în limba dumneavoastră maternă, vă rugăm să contactați partenerul de vânzări Rexroth.</p> <p>Numai un personal calificat poate lucra cu componentele de acționare.</p> <p>Explicații detaliate privind instrucțiunile de siguranță găsiți în capitolul 1 al acestei documentații.</p>
<p><b>▲ OPOZORILO</b> Visoka električna napetost! Življenska nevarnost zaradi električnega udara!</p> <p>Pogonske komponente uporabljajte samo s fiksno nameščenim zaščitnim vodnikom.</p> <p>Pred dostopom do pogonske komponente odklopite napajanje.</p> <p>Upošteвайте čase praznjenja kondenzatorjev.</p>	<p><b>▲ VAROVANIE</b> Vysoké elektrické napätie! Nebezpečnostv ohrozenia života v dôsledku zásahu elektrickým prúdom!</p> <p>Komponenty pohonu prevádzkujte iba s pevne nainštalovaným ochranným vodičom.</p> <p>Pred prístupom na komponenty pohonu odpojte zdroj napätia.</p> <p>Rešpektujte časy vybitia kondenzátorov.</p>	<p><b>▲ AVERTIZARE</b> Tensiune electrică înaltă! Pericol de moarte prin electrocutare!</p> <p>Exploatați componentele de acționare numai cu împământarea instalată permanent.</p> <p>Înainte de intervenția asupra componentelor de acționare, deconectați alimentarea cu tensiune electrică.</p> <p>Țineți cont de timpii de descărcare ai condensatorilor.</p>
<p><b>▲ OPOZORILO</b> Nevarni premiki! Življenska nevarnost!</p> <p>Ne zadržujte se v območju delovanja strojev.</p> <p>Preprečite nenadzorovan dostop oseb.</p> <p>Pred prijemom ali dostopom v nevarno območje varno zaustavite vse gnane dele.</p>	<p><b>▲ VAROVANIE</b> Pohyby prinášajúce nebezpečnostv! Nebezpečnostv ohrozenia života!</p> <p>Nezdrživajte sa v oblasti pohybu strojov a častí strojov.</p> <p>Zabráňte nepovolanému prístupu obsôb.</p> <p>Pred zásahom alebo prístupom do nebezpečnej oblasti uveďte pohony bezpečne do zastavenia.</p>	<p><b>▲ AVERTIZARE</b> Mișcări periculoase! Pericol de moarte!</p> <p>Nu staționați în zona de mișcare a mașinilor și a componentelor în mișcare a mașinilor.</p> <p>Împiedicați accesul neintenționat al persoanelor în zona de lucru a mașinilor.</p> <p>Înainte de intervenția sau accesul în zona periculoasă, opriți în siguranță componentele de acționare.</p>
<p><b>▲ OPOZORILO</b> Elektromagnetna / magnetna polja! Nevarnost za zdravje za osebe s spodbujevalniki srca, kovinskimi vsadki ali slušnimi aparati!</p> <p>Dostop do območij, v katerih so nameščene delujoče pogonske komponente, je za zgoraj navedene osebe prepovedan oz. dovoljen samo po posvetu z zdravnikom.</p>	<p><b>▲ VAROVANIE</b> Elektromagnetické/magnetické polia! Nebezpečnostv pre zdravie osôb s kardiostimulátormi, kovovými implantátmi alebo načúvacími prístrojmi!</p> <p>Prístup k oblastiam, v ktorých sú namontované a prevádzkujú sa komponenty pohonu, je pre hore uvedené osoby zakázaný resp. je dovoljen iba po konzultácii s lekárom.</p>	<p><b>▲ AVERTIZARE</b> Câmpuri electromagnetice / magnetice! Pericol pentru sănătatea persoanelor cu stimuloare cardiace, implanturi metalice sau aparate auditive!</p> <p>Intrarea în zone, în care se montează sau se exploatează componente de acționare, este interzisă pentru persoanele sus numite respectiv este permisă numai cu acordul medicului.</p>

Slovensko	Slovenčina	Română
<p><b>▲ POZOR</b> <b>Vroče površine (&gt; 60 °C)! Nevarnost opeklin!</b></p> <p>Izogibajte se stiku s kovinskimi površinami (npr. hladilnimi telesi). Upošteвайте čas hlajenja pogonskih komponent (najm. 15 minut).</p>	<p><b>▲ UPOZORNENIE</b> <b>Horúce povrchy (&gt; 60 °C)! Nebezpečnosť popálenia!</b></p> <p>Zabráňte kontaktu s kovovými povrchmi (napr. chladiacimi telesami). Dodržiavajte čas vychladenia komponentov pohonu (min. 15 minút).</p>	<p><b>▲ ATENȚIE</b> <b>Suprafețe fierbinți (&gt; 60 °C)! Pericol de arsuri!</b></p> <p>Nu atingeți suprafețele metalice (de ex. radiatoare de răcire). Respectați timpii de răcire ai componentelor de acționare (min. 15 minute).</p>
<p><b>▲ POZOR</b> <b>Nestrokovno ravnanje med transportom in namestitviyo! Nevarnost poškodb!</b></p> <p>Uporablajte ustrezne pripomočke za nameščanje in transport.</p> <p>Uporabite ustrezno orodje in osebno zaščitno opremo.</p>	<p><b>▲ UPOZORNENIE</b> <b>Neodborná manipulácia pri transporte a montáži! Nebezpečnosť poranenia!</b></p> <p>Používajte vhodné montážne a transportné zariadenia.</p> <p>Používajte vhodné náradie a osobné ochranné prostriedky.</p>	<p><b>▲ ATENȚIE</b> <b>Manipulare necorespunzătoare la transport și montaj! Pericol de vătămare!</b></p> <p>Utilizați dispozitive adecvate de montaj și transport.</p> <p>Folosiți instrumente corespunzătoare și echipament personal de protecție.</p>
<p><b>▲ POZOR</b> <b>Nepravilno ravnanje z baterijami! Nevarnost poškodb!</b></p> <p>Ne poskušajte ponovno aktivirati ali napolniti praznih baterij (Nevarnost zaradi eksplozij ali jedkanja).</p> <p>Ne razstavljajte ali poškodujte nobenih baterij. Baterij ne mečite v ogenj.</p>	<p><b>▲ UPOZORNENIE</b> <b>Neodborná manipulácia s batériami! Nebezpečnosť poranenia!</b></p> <p>Nepokúšajte sa reaktivovať alebo nabíjať prázdne batérie (nebezpečnosť výbuchu a poleptania).</p> <p>Batérie nerozoberajte ani nepoškodujte. Nehádzte batérie do ohňa.</p>	<p><b>▲ ATENȚIE</b> <b>Manipulare necorespunzătoare a bateriilor! Pericol de vătămare!</b></p> <p>Nu încercați să reactivați sau să încărcați bateriile goale (pericol de explozie și pericol de arsuri).</p> <p>Nu dezasamblați și nu deteriorați bateriile. Nu aruncați bateriile în foc.</p>

Magyar	Български	Latviski
<p><b>▲ FIGYELMEZTETÉS!</b> <b>Az alábbi biztonsági útmutatások figyelmen kívül hagyása életveszélyes helyzethez vezethet!</b></p> <p>Üzembe helyezés előtt olvassa el, értelmezze, és vegye figyelembe a csomagban található dokumentumban foglaltakat és a biztonsági útmutatásokat.</p> <p>Amennyiben a csomagban nem talál az Ön nyelvéen írt dokumentumokat, vegye fel a kapcsolatot az illetékes Rexroth-képviselővel.</p> <p>A hajtás alkatrészein kizárólag képzett személy dolgozhat.</p> <p>A biztonsági útmutatókkal kapcsolatban további magyarázatot ennek a dokumentumnak az első fejezetében találhat.</p>	<p><b>▲ ПРЕДУПРЕЖДЕНИЕ</b> <b>Опасност за живота при неспазване на посочените по-долу инструкции за безопасност!</b></p> <p>Използвайте продуктите след като сте се запознали подробно с приложената към продукта документация и указания за безопасност, разбрали сте ги и сте се съобразили с тях.</p> <p>Ако текстът не е написан на Вашия език, моля обърнете се към Вашия компетентен търговски представител на Rexroth.</p> <p>Със задвижващите компоненти трябва да работи само квалифициран персонал.</p> <p>Подробни пояснения към инструкциите за безопасност можете да видите в Глава 1 на тази документация.</p>	<p><b>▲ BRĪDINĀJUMS</b> <b>Turpinājumā doto drošības norādījumu neievērošana var apdraudēt dzīvību!</b></p> <p>Sāciet lietot izstrādājumu tikai pēc tam, kad esat pilnībā izlasījuši, sapratuši un ņēmuši vērā kopā ar izstrādājumu piegādātos dokumentus.</p> <p>Ja dokumenti nav pieejami Jūsu valsts valodā, vērsieties pie pilnvarotā Rexroth izplatītāja.</p> <p>Darbus pie piedziņas komponentiem drīkst veikt tikai kvalificēts personāls.</p> <p>Detalizētus paskaidrojumus attiecībā uz drošības norādījumiem skatiet šī dokumenta 1. nodaļā.</p>

Magyar	Български	Latviski
<p><b>▲ FIGYELMEZTETÉS!</b> Magas elektromos feszültség! Életveszélyes áramütés miatt!</p> <p>A hajtás alkatrészeit csak véglegesen telepített védővezetővel üzemeltesse!</p> <p>Mielőtt hozzányúl a hajtás alkatrészeihez, kapcsolja ki az áramellátást.</p> <p>Ügyeljen a kondenzátorok kisülési idejére!</p>	<p><b>▲ ПРЕДУПРЕЖДЕНИЕ</b> Високо електрическо напрежение! Опасност за живота от удар от електрически ток!</p> <p>Работете със задвижващите компоненти само при здраво закрепен заземяващ проводник.</p> <p>Преди работа по задвижващите компоненти, изключете захранващото напрежение.</p> <p>Обърнете внимание на времето за разреждане на кондензаторите.</p>	<p><b>▲ BRĪDINĀJUMS</b> Augsts elektriskais spriegums! Dzīvības apdraudējums elektriskā trieciena dēļ!</p> <p>Piedziņas komponentus darbiniet tikai ar fiksēti uzstādītu zemējumvadu.</p> <p>Pirms darba pie piedziņas komponentiem atslēdziet elektroapgādi.</p> <p>Nemiet vērā kondensatoru izlādes laikus.</p>
<p><b>▲ FIGYELMEZTETÉS!</b> Veszélyes mozgás! Életveszély!</p> <p>Ne tartózkodjon a gépek és a gépalkatrészek mozgási területén belül!</p> <p>Illetéktelen személyeket ne engedjen a gép közelébe!</p> <p>Mielőtt beavatkozik, vagy a veszélyes zónába belép a hajtásokat biztonságosan állítsa le.</p>	<p><b>▲ ПРЕДУПРЕЖДЕНИЕ</b> Опасни движения! Опасност за живота!</p> <p>Не стойте в обсега на движение на машините и частите на машините.</p> <p>Не допускайте непреднамерен достъп на хора.</p> <p>Преди работа или влизане в опасната зона, спрете надеждно приводния механизъм.</p>	<p><b>▲ BRĪDINĀJUMS</b> Bīstamas kustības! Dzīvības apdraudējums!</p> <p>Neuzturieties mašīnu un mašīnas detaļu kustību zonā.</p> <p>Novērsiet nepiederošu personu piekļūšanu.</p> <p>Pirms darba bīstamajās zonās pilnībā apstādiniet piedziņu.</p>
<p><b>▲ FIGYELMEZTETÉS!</b> Elektromágneses / mágneses mező! Káros hatással lehet a szívritmus-szabályozó készülékkel, fémbeültetéssel vagy hallókészülékkel rendelkezők egészségére!</p> <p>Azokra a területekre, ahol hajtások alkatrészeit szerelik és üzemeltetik, a fent említett személyeknek tilos a belépés, illetve csak orvosi konzultációt követően szabad az adott területekre lépniük.</p>	<p><b>▲ ПРЕДУПРЕЖДЕНИЕ</b> Електромагнитни / магнитни полета! Опасност за здравето на хора със сърдечни стимулатори, метални импланти или слухови апарати!</p> <p>Достъпът за гореспоменатите лица до зони, в които ще се монтират и ще работят задвижващи компоненти се забранява, или разрешава само след консултация с лекар.</p>	<p><b>▲ BRĪDINĀJUMS</b> Elektromagnētiskais / magnētiskais lauks! Veselības apdraudējums personām ar sirds stimulatoriem, metāliskiem implantiem vai dzirdes aparātiem!</p> <p>Tuvošanās zonām, kurās tiek montēti un darbināti piedziņas komponenti, iepriekš minētajām personām ir aizliegta, respektīvi, atļauta tikai pēc konsultēšanās ar ārstu.</p>
<p><b>▲ VIGYÁZATI</b> Forró felületek (&gt; 60 °C)! Égésveszély!</p> <p>Ne érjen hozzá fémfelületekhez (pl. hűtőtestekhez)! Vegye figyelembe a hajtás alkatrészeinek kihűlési idejét (min. 15 perc)!</p>	<p><b>▲ ВНИМАНИЕ</b> Горещи повърхности (&gt; 60 °C)! Опасност от изгаряне!</p> <p>Не докосвайте метални повърхности (например радиатори). Сълюдавайте времето на охлаждане на задвижващите компоненти (мин. 15 минути).</p>	<p><b>▲ UZMANĪBU</b> Karstas virsmas (&gt; 60 °C)! Apdedzināšanās risks!</p> <p>Neskarieties pie metāliskām virsmām (piemēram, dzesētāja). Ļaujiet piedziņas komponentiem atdzist (min. 15 minūtes).</p>
<p><b>▲ VIGYÁZATI</b> Szakszerűtlen kezelés szállító táskor és szereléskor! Sérülésveszély!</p> <p>A megfelelő beszerelési és szállítási eljárásokat alkalmazza!</p> <p>Használjon megfelelő szerszámokat és személyes védőfelszerelést!</p>	<p><b>▲ ВНИМАНИЕ</b> Неправилно боравене по време на транспорт и монтаж! Опасност от нараняване!</p> <p>Използвайте подходящо монтажно и транспортно оборудване.</p> <p>Използвайте подходящи инструменти и лични предпазни средства.</p>	<p><b>▲ UZMANĪBU</b> Nepareizi veikta transportēšana un montāža! Traumu gūšanas risks!</p> <p>Izmantojiet piemērotas montāžas un transportēšanas ierīces.</p> <p>Izmantojiet piemērotus instrumentus un individuālos aizsardzības līdzekļus.</p>

Magyar	Български	Latviski
<b>▲ VIGYÁZATI</b> Akkumulátorok szakszerűtlen kezelése! Sérülésveszély!	<b>▲ ВНИМАНИЕ</b> Неправилно боравене с батерии! Опасност от нараняване!	<b>▲ UZMANĪBU</b> Nepareiza bateriju lietošana! Traumu gūšanas risks!
Üres akkumulátorokat ne aktiváljon újra, illetve ne töltsön fel (robbanás- és marásveszély)!	Не се опитвайте да активирате отново или да зареждате разредени батерии (Опасност от експлозия и напръскване с агресивен агент).	Neméginiet ne jauna aktivizēt vai uzlādēt tukšas baterijas (eksplodziju un ķīmisko apdegumu draudi).
Az akkumulátorokat ne szedje szét, és ne rongálja meg! Az akkumulátort ne dobja tűzbe!	Не разглобвайте и не повреждайте батерии. Не хвърляйте батерии в огън.	Neizjauciet un nesabojājiēt baterijas. Nemetiet baterijas ugunī.

Lietuviškai	Eesti	Ελληνικά
<b>▲ ISPĖJIMAS</b> Pavojus gyvybei nesilaikant toliau pateikiamų saugumo nurodymų!	<b>▲ HOIATUS</b> Alljärgnevat ohutusjuhiste eiramine on eluohtlik!	<b>▲ ΠΡΟΕΙΔΟΠΟΙΗΣΗ</b> Κίνδυνος θανάτου σε περίπτωση μη συμμόρφωσης με τις παρακάτω οδηγίες ασφαλείας!
Naudokite gaminį tik kruopščiai perskaitę prie jo pridėtus aprašus, saugumo nurodymus. Susipažinkite su jais ir vadovaukitės naudodami gaminį.	Võtke tooted käiku alles siis, kui olete toodetega kaasasolevad materjalid ning ohutusjuhised täielikult läbi lugenud, neist aru saanud ja neid järginud.	Θέστε το προϊόν σε λειτουργία αφού διαβάσετε, κατανοήσετε και λάβετε υπόψη το σύνολο των οδηγιών ασφαλείας που το συνοδεύουν.
Jei Jūs negavote aprašo gimtąja kalba, kreipkitės į įgaliotus Rexroth atstovus.	Kui Teil puuduvad emakeelseid materjalid, siis rõõrduge Rexrothi kohaliku müügiesinduse poole.	Εάν δεν υπάρχει τεκμηρίωση στη γλώσσα σας, απευθυνθείτε σε εξουσιοδοτημένο αντιπρόσωπο της Rexroth.
Prie pavaros komponentų leidžiama dirbti tik kvalifikuotam personalui.	Ajamikomponentidega tohib töötada üksnes kvalifitseeritud personal.	Μόνο εξειδικευμένο προσωπικό επιτρέπεται να χειρίζεται στοιχεία μετάδοσης κίνησης.
Išsamesnius saugumo nurodymų paaiškinimus rasite šios dokumentacijos 1 skyriuje.	Täpsemad selgitusi ohutusjuhiste kohta leiate käesoleva dokumentatsiooni peatükist 1.	Περαιτέρω επεξηγήσεις των οδηγιών ασφαλείας διατίθενται στο κεφάλαιο 1 της παρούσας τεκμηρίωσης.
<b>▲ ISPĖJIMAS</b> Aukšta elektros įtampa! Pavojus gyvybei dėl elektros smūgio!	<b>▲ HOIATUS</b> Kõrge elektripingel! Eluohtlik elektrilöögi tõttu!	<b>▲ ΠΡΟΕΙΔΟΠΟΙΗΣΗ</b> Υψηλή ηλεκτρική τάση! Κίνδυνος θανάτου από ηλεκτροπληξία!
Pavaros komponentus eksploatuokite tik su fiksuotai instaliuotu apsauginiu laidu.	Käitage ajamikomponente üksnes püsivalt installeeritud maandusega.	Θέτετε σε λειτουργία τα στοιχεία μετάδοσης κίνησης μόνο εφόσον έχει τοποθετηθεί καλά προστατευτικός αγωγός γείωσης.
Prieš priedami prie pavaros komponentų išjunkite maitinimo įtampą.	Lülitage enne ajamikomponentidega tööde alustamist toitepinge välja.	Πριν από οποιαδήποτε παρέμβαση, αποσυνδέστε την τροφοδοσία των στοιχείων μετάδοσης κίνησης.
Atsižvelkite į kondensatorių išsikrovimo trukmę.	Järgige kondensaaorite mahalaadumisaegu.	Λάβετε υπόψη τους χρόνους αποφόρτισης των πυκνωτών.

<b>▲ ISPĖJIMAS</b> Pavojingi judesiai! Pavojus gyvybei!	<b>▲ HOIATUS</b> Ohtlikud liikumised! Eluohtlik!	<b>▲ ΠΡΟΕΙΔΟΠΟΙΗΣΗ</b> Επικίνδυνες τάσεις! Κίνδυνος θανάτου!
Nebūkite mašinų ar jų dalių judėjimo zonoje.	Ärge viibige masina ja masinaosade liikumispääkonnas.	Μην στέκεστε στην περιοχή κίνησης μηχανημάτων και εξαρτημάτων.
Neleiskite netyčia patekti asmenims.	Tõkestage inimeste ettekatvematut sisenevaid masina ja masinaosade liikumispääkonda.	Αποτρέπετε την τυχαία είσοδο ατόμων.
Prieš patekdami į pavojaus zoną saugiai išjunkite pavarą.	Tagage ajamite turvaline seiskamine enne ohupiirkonda juurdepääsu või sisenevaid.	Πριν από την παρέμβαση ή πρόσβαση στην περιοχή κινδύνου, μεριμνήστε για την ασφαλή ακινητοποίηση των συστημάτων μετάδοσης κίνησης.

Lietuviškai	Eesti	Ελληνικά
<p><b>▲ ISPĖJIMAS</b> Elektromagnetiniai / magnetiniai laukai! Pavojus asmenų su širdies stimulatoriais, metaliniais implantais arba klausos aparatais sveikatai!</p> <p>Prieiga prie zonų, kuriose montuojami ir eksploatuojami pavaros komponentai, aukščiau nurodytiems asmenims yra draudžiama arba leistina tik pasitarus su gydytoju.</p>	<p><b>▲ HOIATUS</b> Elektromagnetilised / magnetilised väljald! Terviseohtlik südamestimulaatorite, metallimplantaatide ja kuulmisseedmetega inimestele!</p> <p>Sisenemine piirkondadesse, kus toimub ajami-komponentide monteerimine ja käitamine, on ülalnimetatud isikutele keelatud või lubatud üksnes pärast arstiga konsulteerimist.</p>	<p><b>▲ ΠΡΟΕΙΔΟΠΟΙΗΣΗ</b> Ηλεκτρομαγνητικά/ μαγνητικά πεδία! Κίνδυνος για την υγεία ατόμων με καρδιακούς βηματοδότες, μεταλλικά εμφυτεύματα ή συσκευές ακοής!</p> <p>Η είσοδος σε περιοχές όπου πραγματοποιείται συναρμολόγηση και λειτουργία στοιχείων μετάδοσης κίνησης απαγορεύεται στα προαναφερθέντα άτομα, εκτός αν τους έχει δοθεί σχετική άδεια κατόπιν συνεννόησης με γιατρό.</p>
<p><b>▲ PERSPĖJIMAS</b> Karšti paviršiai (&gt; 60 °C)! Nudėgimo pavojus!</p> <p>Venkite liesti metalinius paviršius (pvz., radiatorių). Išlaikykite pavaros komponentų atvėsimą trukmę (bent 15 minučių).</p>	<p><b>▲ ETTEVAATUST</b> Kuumad välispinnad (&gt; 60 °C)! Põletusohut!</p> <p>Vältige metallsete välispindade (nt radiaatorid) puudutamist. Pidaage kinni ajamikomponentide mahajahutumisajast (vähemalt 15 minutit).</p>	<p><b>▲ ΠΡΟΣΟΧΗ</b> Καυτές επιφάνειες (&gt; 60 °C)! Κίνδυνος εγκαύματος!</p> <p>Αποφεύγετε την επαφή με μεταλλικές επιφάνειες (π.χ. μονάδες ψύξης). Λάβετε υπόψη το χρόνο ψύξης των στοιχείων μετάδοσης κίνησης (τουλάχιστον 15 λεπτά).</p>
<p><b>▲ PERSPĖJIMAS</b> Netinkamas darbas transportuojant ir montuojant! Susižalojimo pavojus!</p> <p>Naudokite tinkamus montavimo ir transportavimo įrenginius.</p> <p>Naudokite tinkamus įrankius ir asmens saugos priemones.</p>	<p><b>▲ ETTEVAATUST</b> Asjatundmatu käsitemine transportimisel ja montaažil! Vigastusohut!</p> <p>Kasutage sobivaid montaaži- ja transpordiseadiseid.</p> <p>Kasutage sobivaid tööriistu ja isiklikku kaitsevarustust.</p>	<p><b>▲ ΠΡΟΣΟΧΗ</b> Ακατάλληλος χειρισμός κατά τη μεταφορά και συναρμολόγηση! Κίνδυνος τραυματισμού!</p> <p>Χρησιμοποιείτε κατάλληλους μηχανισμούς συναρμολόγησης και μεταφοράς.</p> <p>Χρησιμοποιείτε κατάλληλα εργαλεία και ατομικό εξοπλισμό προστασίας.</p>
<p><b>▲ PERSPĖJIMAS</b> Netinkamas darbas su baterijomis! Susižalojimo pavojus!</p> <p>Nebandykite tuščią baterijų reaktyvuoti arba įkrauti (sprogimo ir išėsdinimo pavojus).</p> <p>Neardykite ir nepažeiskite baterijų. Nemeskite baterijų į ugnį.</p>	<p><b>▲ ETTEVAATUST</b> Patारेide asjatundmatu käsitemine! Vigastusohut!</p> <p>Ärge üritage kunagi tühje patareisid reakti-veerida või täis laadida (plahvatus- ja söövitushoht).</p> <p>Ärge demonteerige ega kahjustage patareisid. Ärge visake patareisid tulle.</p>	<p><b>▲ ΠΡΟΣΟΧΗ</b> Ακατάλληλος χειρισμός μπαταριών! Κίνδυνος τραυματισμού!</p> <p>Μην επιδιώκετε να ενεργοποιήσετε ξανά ή να φορτίσετε κενές μπαταρίες (κίνδυνος έκρηξης και διάβρωσης).</p> <p>Μην διαλύετε ή καταστρέφετε τις μπαταρίες. Μην απορρίπτετε τις μπαταρίες στη φωτιά.</p>

## 中文

**▲警告** 如果不按照下述指定的安全说明使用，将会导致人身伤害！

在没有阅读，理解随本产品附带的文件并熟知正当使用前，不要安装或使用本产品。

如果没有您在所在国家官方语言文件说明，请与 Rexroth 销售伙伴联系。

只允许有资格人员对驱动器部件进行操作。

安全说明的详细解释在本文档的第一章。

**▲警告** 高压！电击导致生命危险！

只有在安装了永久良好的设备接地导线后才可以对驱动器的部件进行操作。

在接触驱动器部件前先将驱动器部件断电。

确保电容放电时间。

中文

**▲警告 危险运动！生命危险！**

保证设备的运动区域内和移动部件周围无障碍物。

防止人员意外进入设备运动区域内。

在接近或进入危险区域之前，确保传动设备安全停止。

**▲警告 电磁场/磁场！对佩戴心脏起搏器、金属植入物和助听器的人员会造成严重的人身伤害！**

上述人员禁止进入安装及运行的驱动器区域，或者必须事先咨询医生。

**▲小心 热表面（大于 60 度）！灼伤风险！**

不要触摸金属表面（例如散热器）。驱动器部件断电后需要时间进行冷却（至少 15 分钟）。

**▲小心 安装和运输不当导致受伤危险！当心受伤！**

使用适当的运输和安装设备。

使用适合的工具及用适当的防护设备。

**▲小心 电池操作不当！受伤风险！**

请勿对低电量电池重新激活或重新充电（爆炸和腐蚀的危险）。

请勿拆解或损坏电池。请勿将电池投入明火中。

# Table of contents

<b>1</b>	<b>About this documentation</b>	<b>19</b>
1.1	Editions of this documentation. ....	19
1.2	Presentation of information. ....	19
<b>2</b>	<b>Safety instructions</b>	<b>20</b>
2.1	Important directions on use. ....	20
2.1.1	Indented use. ....	20
2.1.2	Unintended use. ....	22
2.2	Qualification of personnel. ....	22
2.3	General safety instructions. ....	22
2.4	Product- and technology-dependent safety instructions. ....	22
2.4.1	Protection against explosion hazard. ....	22
2.4.2	Protection from electric voltage. ....	23
2.4.3	Protection from mechanical danger. ....	23
2.4.4	Protection against magnetic and electromagnetic fields. ....	23
2.4.5	Protection against ignitable electrostatic discharges. ....	24
2.4.6	Protection against burns. ....	24
2.4.7	Electrostatic sensitive devices (ESD). ....	24
<b>3</b>	<b>Scope of delivery</b>	<b>25</b>
<b>4</b>	<b>Explosion protection</b>	<b>25</b>
4.1	Type-examination certificate. ....	25
4.2	Product description. ....	25
4.3	ATEX labeling for MKE motors (gas). ....	25
4.4	ATEX labeling for MKE motors (dust). ....	26
4.5	Specific conditions. ....	26
4.6	Conditions for use in Equipment Group II, Category 2. ....	27
4.6.1	Maximum housing temperature. ....	27
4.6.2	Connection conditions. ....	27
4.6.3	Grounding. ....	27
4.6.4	Corrosion. ....	27
4.6.5	Switch-off. ....	27
4.6.6	Residual risks. ....	28
4.6.7	Emergency stop. ....	28

<b>5</b>	<b>Identification</b>	<b>29</b>
5.1	Type plate.....	29
5.2	Type codes.....	30
<b>6</b>	<b>About this product</b>	<b>30</b>
6.1	Safety instructions on the product.....	30
6.2	Features and functions.....	32
6.2.1	Basic data.....	32
6.2.2	Mechanical interface.....	33
6.2.3	Thermal motor protection.....	34
6.2.4	Cooling mode.....	35
6.2.5	Encoder.....	36
6.2.6	Degree of protection.....	36
6.2.7	Output shaft, balancing and extension elements.....	36
6.2.8	Holding brake.....	38
6.2.9	Vibration behavior.....	41
6.2.10	Bearing.....	41
6.2.11	Frame size, installation type.....	42
6.2.12	Coating.....	43
6.2.13	Noise emission.....	43
<b>7</b>	<b>Transport and storage</b>	<b>43</b>
7.1	Storage.....	43
7.2	Transport.....	43
7.2.1	Instructions on machine transport.....	44
7.3	Shock load during transport und storage.....	44
<b>8</b>	<b>Assembly</b>	<b>45</b>
8.1	Flange assembly.....	45
8.2	Assemble transmission elements.....	45
8.3	Electrical connection.....	46
8.3.1	Electrical connection general notes.....	46
8.3.2	Wiring diagram.....	48
8.3.3	Terminal boxes (MKE037-E) electrical connection.....	49
8.3.4	Terminal box (MKE047-E) electrical connection.....	51
8.3.5	Terminal boxes (MKE098-E) electrical connection.....	53
8.3.6	Terminal boxes (MKE118-E) electrical connection.....	55
8.3.7	Ground connection.....	58

<b>9</b>	<b>Commissioning and operation</b>	<b>58</b>
9.1	Safety.....	58
9.2	Ambient conditions during operation.....	59
9.2.1	Vibration load during operation.....	59
9.3	Commissioning.....	59
9.4	Operation.....	60
9.5	Operation on foreign converters.....	60
<b>10</b>	<b>Maintenance</b>	<b>62</b>
10.1	Cleaning and servicing.....	62
10.2	Service repair, maintenance and spare parts.....	62
<b>11</b>	<b>Disassembly and exchange</b>	<b>63</b>
11.1	Tools required.....	63
11.2	Replace the motor.....	63
11.3	Preparing storage.....	64
<b>12</b>	<b>Environmental protection and disposal</b>	<b>64</b>
<b>13</b>	<b>Eliminate malfunction</b>	<b>66</b>
<b>14</b>	<b>Technical data</b>	<b>66</b>
14.1	Technical data type plate.....	66
14.2	Axial force.....	67
14.3	Radial force.....	67
14.3.1	MKE037 Radial force.....	67
14.3.2	MKE047 Radial force.....	67
14.3.3	MKE098 Radial force.....	68
14.3.4	MKE118 Radial force.....	68
14.4	Specifications.....	69
14.4.1	MKE037 Specifications.....	69
14.4.2	MKE047 Specifications.....	70
14.4.3	MKE098 Specifications.....	71
14.4.4	MKE118 Specifications.....	72
<b>15</b>	<b>Appendix</b>	<b>73</b>
15.1	EU Declaration of conformity.....	73
15.2	UK Declaration of Conformity (UK Declaration of Conformity).....	74
15.3	UL / CSA.....	75
15.4	China RoHS 2.....	75
	<b>Index</b>	<b>76</b>

# 1 About this documentation

## 1.1 Editions of this documentation

This instruction must be observed by assemblers, operators, service engineers and facility operators. It contains notes about handling a motor. Before operating motors, read this operating instruction to ensure a safe and smooth functionality and a long motor lifetime.

Table 1: Record of revisions

Edition	Release date	Notes
01	2021-04	First edition
02	2021-06	Corrections, harmonization with project planning manual, edition 01
03	2022-05	Supplemented conformity UKCA, CCC

## 1.2 Presentation of information

### Safety instructions

The safety instructions in this documentation include signal words (danger, warning, caution, note) and a signal symbol (acc. to ANSI Z535.6-2006).

The signal word is intended to draw your attention to the safety instructions and describes the seriousness of the danger. The warning triangle with exclamation mark indicates the danger for persons.

#### ▲ DANGER

Non-compliance with this safety instructions **will** result in death or severe personal injury.

#### ▲ WARNING

Non-compliance with this safety instructions **can** result in death or severe personal injury.

#### ▲ CAUTION

Non-compliance with this safety instructions **can** result in moderate or minor personal injury.







#### NOTICE

Non-compliance with this safety instructions **can** result in material damage.

### Safety symbols

In the documentation, the following internationally standardized safety signs and graphic symbols are used. The meaning of the symbols is described in the table.

Table 2: Meaning of safety signs

Safety sym- bols	Meaning
	Warning against dangerous electric voltage
	Warning against hot surfaces
	Warning against rotating machine parts
	Warning against overhead load
	Electrostatic sensitive devices
	Prohibited for persons with active implantable medical devices (AIMD) or passive metallic implants (body aids) as well as for pregnant women

### Safety sym- bols



Do not carry along metal parts or tools.



Hammer scales are forbidden

### Meaning of symbols

Table 3: Meaning of symbols

Symbol	Meaning
	Reference to supplementary documentation
	Explosion protection identification
	The UL Recognized Component Mark identifies recognized component parts which are components of a bigger product or system.
	CE means "Conformité Européenne". The CE-marking expresses the conformity of a product with relevant EC-regulations.
	UKCA means "UK Conformity Assessed". The UKCA-marking expresses the conformity of a product with all valid statutory requirements of the United Kingdom.
	CCC - China Compulsory Certification
	Components for the use in systems for "integrated safety technique" prepared.
	The symbol indicating "separate collection" for all batteries and accumulators is the crossed-out wheeled bin.

### Markup

The following markups are used for a user-friendly text information representation:

 **Remark:** This note gives important information, which must be observed.

- Listings on the first level contain a bullet point
  - Listings on the second level contain a dash

### Instruction

- Instruction
  - ➔ Result of one instruction

### Instruction multilevel

1. ➤ Action step one
  - ➔ Result of an instruction
2. ➤ Action step two
  - ➔ Result of an instruction

Please comply with the order of the handling instructions.

## 2 Safety instructions

Observe the general safety notes in this chapter and the safety instructions in this documentation. Therewith, you avoid personal danger, damage and errors.

### Keep this instructions!

This operating instruction must be stored and transferred in case of sale during the complete product lifetime.

### 2.1 Important directions on use

#### 2.1.1 Indented use

Prerequisites for proper and safe use of the motors are proper transport, appropriate storage, proper assembly and connection, careful maintenance, operation and overhaul.

The motors have been exclusively designed for installation in industrial machinery. The motors have been designed and manufactured in compliance with the directives and harmonized standards specified in the following.

#### Product standards

EN 60034-1:2010 + Cor.:2010	Rotating electrical machines - Part 1: Rating and performance (IEC 60034-1:2010, modified)
UL 1004-1	Rotating electrical machines - General requirements
UL 1004-6	Servo and stepper motors
CSA C22.2 NO. 100	Motors and generators

#### Valid within EU / UK

##### Directives

ATEX Directive 2014/34/EU

UK Directive - UKSI 2016: 1107 (as amended by UKSI 2019: 696)

##### EN Standards / UK

EN IEC 60079-0:2018/ AC:2020	Explosive atmospheres - Part 0: Equipment - General requirements (IEC 60079-0:2017)
EN 60079-1:2014/ AC:2018-09	Explosive atmospheres - Part 1: Equipment protection by flameproof enclosures "d" (IEC 60079-1:2014/ COR1:2018)
EN 60079-31:2014	Explosive atmospheres - Part 31: Equipment dust ignition protection by enclosure "t" (IEC 60079-31:2013)

#### Field of application in China

##### Directives (China)

CNCA-C23-01:2019	Implementation Rules of China Compulsory Certification on Explosion Proof Electrical Products
------------------	---

##### GB standards (China)

GB/T 3836.1-2021	Explosive atmospheres -- Part 1: Equipment -- General requirements
GB/T 3836.2-2021	Explosive atmospheres -- Part 2: Equipment protection by flameproof enclosures "d"
GB/T 3836.31-2021	Explosive atmospheres -- Part 31: Equipment dust ignition protection by enclosure "t"

The observance of and compliance with the specifications of the operating instructions (DOK-MOTOR\*-MKE\*GEN3\*\*\*-PRRS-\*\*-P) are part of the intended use.

The here described motors are only allowed to be used in an area for components for Group II, Category 2G/2D or Gb, Db.

The machine manufacturer must evaluate the electric and mechanic safety as well as environmental influences in the assembled state of the machine according to the Machine Directive 2006/42/EC and DIN EN 60204-1 (safety of machines).

The electrical installation must comply with the protection requirements of EMC Directive 2014/30/EU. The plant manufacturer is responsible for appropriate installation (for example: physical separation of signal and power cables, using shielded cables, ...). The EMC instructions of the converter manufacturer must be observed.

The motors must be left in their original state. It is not allowed to do any constructional modifications. In the case of contravention, applicability according to intended use will expire.

The machine may not be commissioned before conformity with these directives has been confirmed.

### 2.1.2 Unintended use

Any use of the MKE motors outside of the specified fields of application or under operating conditions and technical data other than those specified in this documentation is considered to be inappropriate use.

Do not use the motors if the ambient conditions require a higher ATEX protection category than specified on the type plate of the motors.

Direct operation on the three-phase network is forbidden.

## 2.2 Qualification of personnel

Any work with or on the described product may only be done by qualified or skilled personnel. For the purpose of this manual, qualified personnel means persons who are familiar with transporting, installing, mounting, commissioning and operating the components of the electrical drive and control system and the associated hazards and have an appropriate qualification for their job. Qualification of personnel contains knowledge and observance of the specifications in EN 60079-14:2014 Explosive atmospheres - Part 14: Electrical installations design, selection and erection (IEC 60079-14:2013) (*GB/T 3836.15:2017 Explosive atmospheres - Part 15: Electrical installations design, selection and erection (IEC 60079-14:2007-12, MOD)*).

All persons working on, with or in the vicinity of an electrical system must be informed of the relevant safety requirements, safety guidelines and internal instructions EN 50110-1:2013 (Operation of electrical installations - Part 1: General requirements).

## 2.3 General safety instructions

**Important! Please read all instructions before motor installation.**

Do not install or operate motors or components of the electric drive and control system before you have not carefully read all delivered documents.

Please observe the particular applicable national, local and system-specific regulations, the safety instructions in the documentation and the warning and informative labels on the motors.

**Improper use of the motors and failure to follow the safety instructions in this document may result in material damage, personal injury, electric shock or, in extreme cases, to death!**

In the case of damage due to non-observance of the safety notes, Bosch Rexroth assumes no liability.

Applications for functional safety are only allowed if the motors have the SI-sign on the rating plate.

## 2.4 Product- and technology-dependent safety instructions

### 2.4.1 Protection against explosion hazard



**Product use only in hazardous areas according to the specified labeling on the product**

This product is only allowed to be used in an area of use which is specified on the type plate according to the explosion protection standards. In the case of several Ex designations labelled on the type plate, like gas and dust protection, please observe that during operation only one hazardous atmosphere occurs. Simultaneous occurrence of gas and dust Ex atmospheres is not permitted.

Do any maintenance in non-hazard atmosphere.

**Observe the conditions on use**

Observe the notes in the application conditions and do not exceed the specified limit values.

## Observe residual risks

Specified residual risks and special using conditions must be evaluated by the plant manufacturer and operator according to the product application. This makes own measures necessary to prevent risks.

### 2.4.2 Protection from electric voltage

**Work required on the electric system may only be carried out by skilled electricians. Tools for electricians (VDE tools) are absolutely necessary.**

Before working:

- Enable.
- Secure against reactivation.
- Ensure de-energization.
- Ground and short-circuit.
- Cover or shield any adjacent live parts.

After completing the job, cancel the measures in reverse order.

**Dangerous voltage occurs during operation! Danger to life, risk of injury by electric shock!**

- Before start-up, connect the protective conductors on all electric components according to the connection plan.
- Operation, even for short measuring purposes is only allowed with fixed connected protective conductor on the specified points of the components.

### 2.4.3 Protection from mechanical danger

**Dangerous movements! Danger to life, risk of injury, heavy injury or material damage.**

- Do not stay within the motion zone of the machine. Avoid unauthorized access into the danger zone.
- Additionally secure vertical axes to prevent them from sinking or descending after having shutdown the motor, for instance as follows:
  - Mechanically lock the vertical axis,
  - providing an external braking / catching / clamping device, or
  - ensure sufficient weight compensation of the axes.

Only using the serially delivered **motor holding brake** or an external holding brake activated by the drive controller **is not suitable for personal protection!**

**Rotating parts! Danger to life, risk of injury, heavy injury or material damage.**

- Secure key and/or transmission elements against ejection.
- Install covers on dangerous rotating machine parts before start-up.

### 2.4.4 Protection against magnetic and electromagnetic fields

**Health hazard for persons with active body aids or passive metallic implants and for pregnant women.**

Magnetic and electromagnetic fields are created in the direct environment of live conductors or permanent magnets of electro motors and are a serious danger for persons.

Observe the country-specific regulations. For Germany, please observe the specifications of the occupational insurance association BGV B11 and BGR B11 regarding “electromagnetic fields”.

- For persons with active body aids (like heart pacemakers), passive metallic implants (like hip prosthesis) and pregnant women possible hazards exist due to electro magnetic or magnetic fields in direct environment of electric drive and control components and the corresponding live conductors.

Access into these areas can be dangerous for these persons:

- Areas, in which components of electrical drive and control systems and corresponding live conductors are mounted, activated or operated.
  - Areas in which motor parts with permanent magnets are stored, repaired or assembled.
- Above mentioned persons must contact their attending physician before entering these areas.
  - Please observe the valid industrial safety regulations for plants which are fitted with components of electrical drive and control systems and corresponding live conductors.

#### **Crushing hazard of fingers and hands due to strong attractive forces of the magnets!**

- Handle only with protective gloves.

#### **Risk of destruction of sensitive parts! Data loss!**

- Keep watches, credit cards, check cards and identity cards and all ferromagnetic metal parts, such as iron, nickel and cobalt away from permanent magnets.

### **2.4.5 Protection against ignitable electrostatic discharges**

#### **Danger of explosion due to electrostatic discharge**

Electrostatic discharges may ignite gases, vapors and dust. Electrostatic charges may be caused e.g. by the following processes:

- electrostatic painting
- pneumatically conveyed dust or bulk material

- hydraulically conveyed or flowing liquids and droplets
- mechanically driven belts, brushes and films, etc.

#### **Danger of explosion due to highly charge-generating processes**

Highly charge-generating processes may cause bush discharges or propagating bush discharges and lead to explosions. This must be prevented. This, in turn, may lead to death, severe injury and damage to property.

#### **Carry out cleaning work only with a moist cloth**

Clean the motor with a moist cloth to avoid electrostatic charge. Rubbing with non-conductive materials must be avoided to prevent electrostatic charges resulting in ignition hazards.

### **2.4.6 Protection against burns**

#### **Risk of burns due to hot motor surfaces!**

- Avoid contact with hot motor surfaces. **Temperatures may rise over 60 °C.**
- Allow the motors to cool down long enough before touching them.
- Temperature-sensitive components may not come into contact with the motor surface. Ensure appropriate mounting distance of connection cables and other components.

### **2.4.7 Electrostatic sensitive devices (ESD)**

The motors contain parts which underlie an electrostatic danger. These components, especially temperature sensors of the motor winding can be destroyed by improper use.

Avoid, e.g. direct contact of open wires or contacts of the connection cable of temperature sensors without being electrostatically discharged or grounded.

**ⓘ Remark:** Do suitable ESD protective measures before you handle imperiled components (e.g. ESD protective clothes, wristlets, conductive floor, grounded cabinets and working surfaces).

## 3 Scope of delivery

The scope of delivery of a MKE synchronous motor contains:

- Motor in original package
- Additional type plate
- Operating instructions with safety instructions
- Protective coverings for output shaft and connection points
- Accompanying papers

On delivery, immediately verify whether the delivered goods are those specified on the delivery note. The forwarder must be promptly informed of any damage on the packaging and goods, which is detected on delivery. Start-up of damaged goods is prohibited.

## 4 Explosion protection

### 4.1 Type-examination certificate

A type approval test was done for the motors. The fulfillment of the basic safety and health requirements for concept and assembly of the motors in appropriate use in hazardous areas is confirmed by the following notified bodies.

#### ATEX (Directives 2014/34/EU)

Motor	Notified body	Test number
MKE037	0102	PTB 09 ATEX 1128 X Ausgabe 1
MKE047	0102	PTB 09 ATEX 1128 X Ausgabe 1
MKE098	0102	PTB 09 ATEX 1128 X Ausgabe 1
MKE118	0102	PTB 09 ATEX 1127 X Ausgabe 1

#### UKCA (UKSI 2016: 1107 (as amended by UKSI 2019: 696) )

Motor	Notified body	Test number
MKE037	0843	UL22UKEX2248X Rev. 0
MKE047	0843	UL22UKEX2248X Rev. 0
MKE098	0843	UL22UKEX2248X Rev. 0
MKE118	0843	UL22UKEX2247X Rev. 0

#### CCC (CNCA-C23-01:2019)

Motor	Notified body	Test number
MKE037	CQM	2022122301115765
MKE047	CQM	2022122301115765
MKE098	CQM	2022122301115765
MKE118	CQM	2022122301115765

### 4.2 Product description

Three-phase synchronous motors of type MKE037, -047, -098, -118 operate with drive systems and are designed in the ignition protection flameproof enclosure "db" and "tb". These motors are fitted with three temperature sensors within the winding to keep the temperature class.

The housing is made of aluminum / aluminum die casting. Cooling is done via heat exchange of the open coolant circuit by temperature difference between housing and surrounding coolant (air).

The motors can be fitted with a holding brake and with a Multiturn or Singleturn encoder.

MKE motors are supplied with dummy plugs without sealings. The electrical connection is made via connecting cables, which are fed into the terminal box via Ex cable glands (Ex-KLE) and connected to terminals. The terminal box has threaded openings for Ex-KLE for connecting power and encoder cables. The Ex cable and line entries as well as the connection cables must be selected by the machine manufacturer or operator on the basis of the applicable regulations and installed according to the manufacturer's specifications.

### 4.3 ATEX labeling for MKE motors (gas)

MKE motors are suited for use in hazardous areas with gas atmosphere according to the following labeling.

## Specific conditions

## ATEX Directive labeling (gas)

## UKSI directive labeling (gas)

 II 2G**Sign**    **Meaning** Symbol Ex

II    Equipment group II. Equipment is suitable for all potentially explosive areas other than firedamp-endangered excavations.

2    Equipment in category 2 is intended for use in areas which has to be calculated that an explosive atmosphere of gas, dust, fog, or dust/air mixtures can occur occasionally.

G    G = Gas

## Labeling ATEX / UKSI / CCC (gas)

**Ex db IIB T4 Gb****Sign**    **Meaning**

Ex    The standard for explosion protection has been applied.

db    Flameproof enclosures (for EPL Gb)

IIB    Group II electrical equipment is intended for use in areas where explosive gas atmospheres ("B": typical gas is ethylene) are likely to occur, except for fire-damp-prone mine workings.

T4    Maximum surface temperature 135 °C

Gb    Equipment Protection Level (EPL) Classification Gb for equipment with "high" level of protection for use in gas explosive atmospheres where there is no risk of ignition during normal operation or foreseeable failures/malfunctions.

## 4.4    ATEX labeling for MKE motors (dust)

MKE motors are suited for use in hazardous areas with gas atmosphere according to the following labeling.

## Labeling ATEX Directive (dust)

## UKSI directive labeling (dust)

 II 2D**Sign**    **Meaning** Symbol Ex

## Labeling ATEX Directive (dust)

## UKSI directive labeling (dust)

 II 2D

II    Equipment group II. Equipment is suitable for all potentially explosive areas other than firedamp-endangered excavations.

2    Equipment in category 2 is intended for use in areas which has to be calculated that an explosive atmosphere of gas, dust, fog, or dust/air mixtures can occur occasionally.

D    G = Gas

## Labeling ATEX / UKSI / CCC (dust)

**Ex tb IIIC T135°C Db****Sign**    **Meaning**

D    D = Dust

Ex    The standard for explosion protection has been applied.

tb    Protection by housing (for EPL Db);

IIIC    Electric devices of group IIIC are intended for use in areas where an explosive dust atmosphere (C: conductive dust) must be expected, except areas susceptible to fire damp.

T135°C    Maximum surface temperature 135 °C

Db    Equipment Protection Level (EPL) Classification Db for equipment with "high" level of protection for use in combustible dust atmospheres where there is no risk of ignition during normal operation or foreseeable failures/malfunctions.

## 4.5    Specific conditions

**▲ WARNING**

**Explosion hazard and danger to life, or substantial property damage!**

All used **components and accessory parts** must comply with the requirements for explosion protection.

The **conditions on use** given in this documentation must be taken into account for any project planning and be observed during operation.

## Notes about test number

The X-marking in the test number is an indication of special conditions that must be observed in conjunction with the safety and health requirements specified in the underlying standards. The following special conditions must be observed for the safe operation of the motors in the plant:

- The permissible ambient temperature range is 0 ... 40 °C.
- The gap width and length acc. to EN 60079-1:2014/AC:2018-09, GB/T 3836.2-2021, were exceed or fall below.
- A repair of flameproof gaps must be done regarding the specifications of the manufacturer. A repair according to the values in EN 60079-1:2014/AC:2018-09, GB/T 3836.2-2021 is not allowed.
- Maintenance and repair of motors must exclusively be done by the certified Rexroth service.
- Screws with at least strength class 8.8 must be used to close off the flameproof enclosure (housing, terminal box, ...).
- Only those components required for the installation and mounting of components (Ex cable glands, connecting parts, ...) are approved which technically comply with the standards of the Declaration of Conformity, are suitable for the operating conditions and have a separate certificate. Observe the special conditions of the components.

## 4.6 Conditions for use in Equipment Group II, Category 2.



### 4.6.1 Maximum housing temperature

In the case of intended use, the maximum housing temperature is significantly below 135 °C.

Observe external heat and cooling sources when determining the operation temperature. Project-

specific electrical/thermal evaluations must be carried out by the customer if they deviate from the Bosch Rexroth specification. If necessary, project-specific metrological verifications are required that reflect the actual ambient conditions at the place of use.

### 4.6.2 Connection conditions

The motors can be operated with Bosch Rexroth controllers. In the case of using drive controllers of other manufacturers, the following special conditions must be fulfilled → Chapter 9.5 “Operation on foreign converters” on page 60. Depending on the drive controller or third-party converter used, function-tested tripping devices with the  II 2 G or  II 2 D designation may be required to evaluate the temperature sensors.

### 4.6.3 Grounding

The motors must be grounded via a motor cable and via a second separate ground conductor with minimum **4 mm<sup>2</sup>** cross section. Check the proper installation of the protective and ground conductor connection before startup.

- Protective conductor motor cable
- Ground conductor see → Chapter 8.3.7 “Ground connection” on page 58

The redundant protective conductor installation ensures a safe drain of occurring discharge currents even in error case (e. g.. at interrupted protective conductor).

### 4.6.4 Corrosion

Prevent motor corrosion which can occur due to aggressive substances like certain coolants and lubricants as well as cutting oils or salt mist.

### 4.6.5 Switch-off

Energies stored in the intermediate circuit have to be reduced or insulated as soon as possible through the activation of the emergency stop device, so that in the case of a failure the risk of an effect into the danger zone is reduced.

For example, this can be achieved as follows:

- Reduce the energy via an intermediate short circuit. For information on the DC link short-circuit function, refer to the documentation of the control device; when using third-party inverters, contact the manufacturer.
- Isolation of the energies before they are transferred into the potentially explosive atmosphere by isolating the voltage of the lines and motors present in the potentially explosive atmosphere.

#### 4.6.6 Residual risks

The existing residual risks are to be observed by the user, when the installation is designed.

- Overstress
  - When the motor is overloaded, including cases where errors in the mechanical or electrical equipment of the machine cause such overloading, high temperatures may occur that result in explosion hazards.
- Operation in explosive dust atmosphere.
  - An operation in explosive dust-atmosphere can build a layer on the motor during a residence time, which does no longer ensure a sufficient motor cooling.
- Grounding and discharge currents
  - Variable-speed drive systems cause unavoidable discharge currents. Please observe a proper installation of protective conductor and potential equalization line. In the case of interrupted protective conductor and potential equalization line due to occurring error cases during operation or faulty connections, for example, can raise sparks on transition points.
- Temperature control
  - The failure of the temperature monitor in the device system may occur, as the result of an error, and might not be detected, even if the motor is operated within the normal temperature range and load cycle.

#### 4.6.7 Emergency stop

Accumulated energy in the drive controller must be dispersed or isolated as quickly as possible when the **emergency shutdown system** is actuated, so that the risk of an effect into the danger zone is reduced in the event of a failure.

The user has the following possibilities:

- The isolation of the energy from the drive unit output is ensured if, in addition to switching off the power, the drive control unit is electronically disabled in the event of an emergency shutdown. This is done by switching off the mains contactor with subsequent fault reaction of the actuator due to the mains failure (see F281). The user must set the required drive-side fault response on the drive unit using the drive parameters (see P-0-0119) in accordance with the functional description.
- To ensure that the encoder supply lines are also voltage-free, the control voltage of the drive unit must also be switched off.

If the control voltage and power are switched off at the drive unit, the output on the motor side is automatically electronically interlocked via the output stage and possible stored energies in the DC link are thus isolated on the output and motor side.

- If it is possible, the DC link short-circuit can be used to quickly dissipate the energies in the DC link of the drive unit after disconnection from the mains.

Irrespective of these possibilities, the user must always check with a suitable measuring device whether parts of the system are still under residual voltage (e. g. caused by residual energies of capacitors in filters and drive units, etc.) before working on the system - as specified in the safety instructions. Wait for their discharging time.

### Other environmental influences

Observe the notes regarding the dangers due to external interference such as , for example:

- Operation within the permissible ambient conditions
- Vibration and shock load
- Protection of protective conductor connections against dirt, corrosion, moisture and/or aggressive materials, etc.

## 5 Identification

### 5.1 Type plate

The type plate is provided for identification of the motor and contains all significant electric data, serial number, manufacturing date, mark of conformity, manufacturer information and the classification according to explosion-protection.

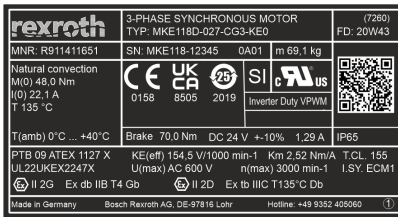

Fig. 1: Type plate MKE (Conformity E)

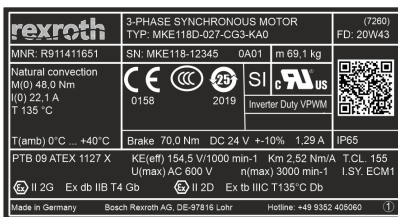



Fig. 2: Type plate MKE (Conformity A)

**Remark:** Before installing the motor, make sure that it is marked accordingly and has a sufficiently high protection class for your application.

Table 4: Type plate specification MKE

Symbol	Meaning
3-PHASE SYNCHRONOUS MOTOR	Type of machine / product
TYPE	Type designation
FD	Manufacturing date ( <b>20W43</b> ) <b>22:</b> Year <b>2020</b> <b>43:</b> Calendar week
MNR	Material number (Rexroth product)
SN	Serial number
m	Mass
Natural convection	Cooling mode, natural convection
M(O)	Standstill torque - 60K
I(O)	Standstill current - 60K
T 135 °C	Maximum surface temperature
SI	Use in systems for "Integrated Safety Technology" prepared.
Inverter Duty VPWM	Supply by converter ( <b>V</b> = Voltage-indirect converter) and PWM control process ( <b>Pulse Width Modulation</b> )
Brake	Holding brake data (optional)
IP65	Degree of protection IPxx
Tamb	Ambient temperature during operation
KEeff	R.m.s. voltage constant
Km	Torque constant
T.CL.	Thermal class
PTB...	ATEX type test certificate number
UL22UKEx...	UKEx type test certificate number
U(max)	Maximum voltage UL
n(max)	Maximum speed
I.SY.	Insulation system identification
	ATEX labeling explosion protection (gas) II 2G
	ATEX labeling explosion protection (dust) II 2D
Manufacturer information	Made in Germany / Bosch Rexroth AG, 97816 Lohr, Germany / Hotline +49 9352 405060

Table 5: Meaning of marks of conformity

Certification mark	Meaning
	The UL Recognized Component Mark (UL recognized) identifies recognized component parts which are components of a bigger product or system.
 0158	The CE-marking confirms the conformity of a product with relevant EC-regulations. In addition, the (4-digit) identification number of the notified body is indicated
 8505	The UKCA-marking confirms the conformity of a product with relevant regulations. In addition, the (4-digit) identification number of the notified body is indicated
	The CCC-marking confirms the conformity of a product with relevant regulations.
 2021	Motors labelled with the symbol EFUP 25 (environmental-friendly use period) can be used for 25 years as intended before substances limited in their concentration according to China RoHS2 may leak and subsequently pose a risk to environment and health. The year of manufacturing is notified under the symbol.

## 5.2 Type codes

The type code is printed onto the type plate of the motor. For the meaning of the type code refer to the following details.

Type codes, meaning of the digits									
MKE037B - 047 - AG1 - BE0N									
1	3	5	7	9					
	2	4	6	8	10				
MKE118B - 058 - GG1 - KE0									
1	3	5	7	9					
	2	4	6	8	10				
1	Product								
2	Frame size								
3	Frame length								

Type codes, meaning of the digits	
4	Winding
5	Encoder
6	Shaft
7	Holding brake
8	Electrical connection
9	Conformity
	E: Certified according to ATEX and UKEx
	A: Certified according to ATEX and CCC Ex
10	Other designs (MKE037, -047, 098) / cable gland (MKE118)

## 6 About this product

### 6.1 Safety instructions on the product

Please note the safety and prohibitive sign on the motor. The sign significance is explained in the following.

Symbol	Meaning
	<b>Caution</b> Use motor cables with a thermal stability of at least 80°C (176°F).
	<b>Plug-in connector</b> Never disconnect plug connectors under load
	<b>Battery</b> Change only outside of hazardous areas.

Symbol	Meaning
	<b>Motor damage due to strikes onto the motor shaft</b> Do not strike the shaft end and do not exceed the allowed axial and radial forces of the motor.

Symbol	Meaning
	<b>Hot surfaces with temperatures over 60 °C may cause burns</b> Let the motors cool down before working on the motors or in close proximity to the motors. The thermal time constant stated in the technical data is a measure for the cooling time. Cooling down can require up

Symbol	Meaning
	to 140 minutes. - Wear safety gloves. - Do not work on hot surfaces.

## 6.2 Features and functions

### 6.2.1 Basic data

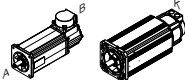
<b>Product</b>	3~ PM motor	
<b>Type</b>	MKE	
<b>Ambient temperature during operation</b>	0 ... 40 °C (without de-rating)	
<b>Type of protection</b>	IP65 with shaft sealing ring EN 60529:1991 + A1:2000 + A2:2013	
<b>Cooling mode</b>	IC410, Self-cooling EN 60034-6:1993	
<b>Motor design</b>	IM B5 EN 60034-7:1993 + A1:2001	
<b>Coating</b>	Varnish RAL 9005	
<b>Flange</b>	similar to DIN 42948	
<b>Shaft end</b>	Cylindrical (DIN 748-3), centering hole with thread "DS" (DIN 332-2:1983-05), Optional with keyway (full-key balancing)	
<b>Concentricity, run-out, alignment</b>	Standard tolerance N (DIN 42955:1981-12)	
<b>Oscillating quantity level</b>	Level A (EN IEC 60034-14:2018) up to rated speed	
<b>Installation altitude</b>	0 ... 1,000 m above NN (without de-rating)	
<b>Sound pressure level</b>	MKE037 ... MKE118: < 75 dB(A) +3 dB(A)	
<b>Thermal class</b>	155 (F) (EN 60034-1:2010 + Cor.:2010 <i>GB/T 755:2019</i> )	
<b>Encoder system</b>	A (optically, Singleturn Hiperface, 128 signal periods) B (optical, Singleturn EnDat 2.1, 2,048 signal periods) C (optically, Multiturn Hiperface, 128 signal periods) D (optical, Multiturn Hiperface, 2,048 signal periods)	
<b>Electrical connection</b>	Terminal box	
<b>Holding brake (option)</b>	Electrically released $U_N$ 24V DC ( $\pm 10\%$ )	
<b>Motor ends, position of the electrical connection</b>		A: A side (Drive End <b>DE</b> ) B: B side (Non Drive End <b>NDE</b> ) K: Terminal box

 **Remark:** In the case of special design, details named in the operating instructions can deviate. In this case, order the supplementary documentation.

## 6.2.2 Mechanical interface

### Dimensions (flange)

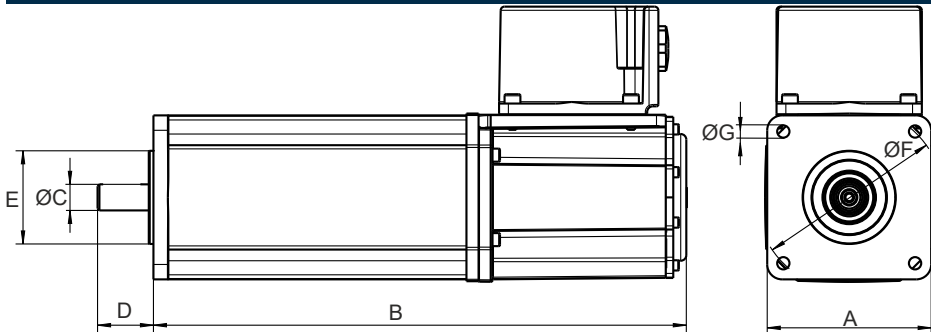

Type	A	B	C	D	E	F	G
	□ Flange [mm]	Length [mm]	Shaft Ø [mm]	Shaft length [mm]	Centering collar [mm]	Hole circle [mm]	Mounting holes [mm]
MKE037	60	283 +5	9	20	40	70	4.5
MKE047	88	287 +5	14	30	50	100	6.6
MKE098	144	383 +5	24	50	110	165	11
MKE118B	194	489 +5	32	60	130	215	14
MKE118D	194	662 +5	32	60	130	215	14

### Mounting screws tightening torque

Screw <sup>1)</sup>	M4	M6	M8	M10	M12	M16
Mounting holes ø [mm]	4.5	6.6	9	11 / 12	14	18
Tightening torque M <sub>A</sub> [Nm] bei μ <sub>K</sub> = 0.12	3.0	10.1	24.6	48	84	206
Washer	-	-	yes	yes	yes	yes

<sup>1)</sup> Screws according to EN ISO 4762:2004 or EN ISO 4014:2011. Fastening class 8.8. The screw lengths depends on material and installation situation. The specified tightening torque must be ensured.

Dimensions KLE connection thread

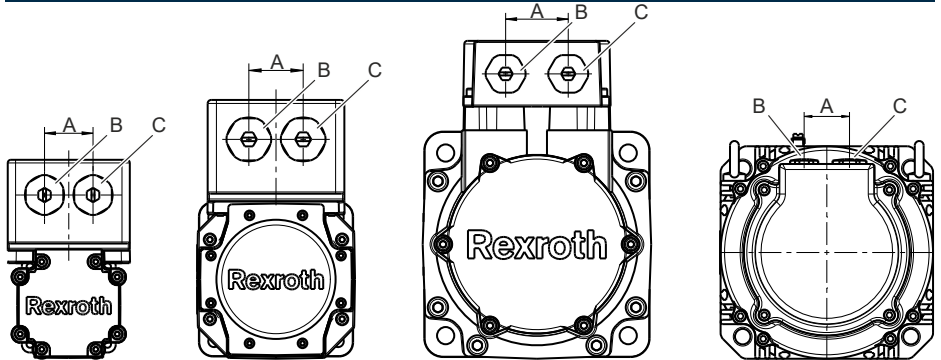

Type	A	B	C
MKE037	31	M20 × 1.5	M20 × 1.5
MKE047	31	M20 × 1.5	M20 × 1.5
MKE098	40	M20 × 1.5	M20 × 1.5
MKE118	41	M20 × 1.5	M25 × 1.5

### 6.2.3 Thermal motor protection

The motor temperature is monitored by two systems that are operated independently of each other. The mounted **temperature sensor** and the drive-internal **temperature model** ensure the best protection of motors against thermal overload.

**MKE motors are protected against impermissible heating by a PTC drilling integrated in the motor winding.**

A series circuit of three PTC thermistors (one PTC resistor per string) is installed in each motor. The servomotor must be operated with a functionally tested triggering device in order that the maximum surface temperature of the motor cannot be exceeded. Voltage disconnection occurs when only one PTC is heated up to nominal tripping temperature ( $130\text{ °C} \pm 5\text{ °C}$ ) by the winding.

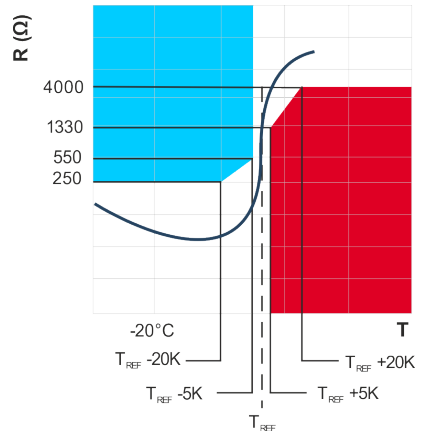





Fig. 3: Temperature-resistance diagram according to IEC60034-11:2004, DIN 44081 (single), DIN 44082 (drilling).

Temperature range	Resistance	Measuring voltage [V <sub>DC</sub> ]
-20 °C to T <sub>REF</sub> -20K	20 Ω to 250 Ω	≤2.5 V
Temperature range 90 °C - 160 °C		
T <sub>REF</sub> -5K	≤550 Ω	≤2.5 V

Temperature range	Resistance	Measuring voltage [V <sub>DC</sub> ]
T <sub>REF</sub> +5K	≤1330 Ω	≤2.5 V
T <sub>REF</sub> +15K	≤4,000 Ω	≤7.5 V pulsed

The resistance rises sharply in the range of the nominal response temperature. A safe shutdown of the motor can be done via the following temperature evaluation:

#### Safe possibility of shutdown

- directly by a functionally tested triggering device (acc. to  II 2G or  II 2D), (a motor protection relais SIRIUS 3RN2 (Siemens) , for example.
- directly with a converter and an integrated safety function SMT (Function Safe Motor Temperature)
- by a functionally tested triggering device (acc. to  II 2G or  II 2D) ( a motor protection relais SIRIUS 3RN2 (Siemens)) and a double channel connection with a Safety Integrated Function STO at the converter “

#### Safe disconnection of the load circuit must be ensured.

The threshold values for motor temperature monitoring are contained in the technical data or within the encoder data memory and are read in and monitored automatically during the operation with compatible Rexroth controllers. Threshold values for MKE motors are:

- Motor-warning temperature (125 °C)
- Motor-disconnection temperature (130 °C)

The temperature signal is transmitted via the motor interface -X2 (T1, T2).

Monitoring for a maximum value of the resistance ensures that any cable breakage that may occur is detected as a fault.

## 6.2.4 Cooling mode

### Self-cooling (IC410)

In case of self-cooling motors, the heat dissipation is realized via natural convection and radiation to the ambient air as well as by heat conduction to the machine construction.

The specified nominal data is reached at ambient temperatures of 0 ... 40 °C. Unhindered vertical convection has to be ensured by a sufficient distance of 100 mm to adjacent components. The allowed limit temperatures must be kept in the case of deviating minimum distances.

Pollution of the surface of the motor reduces heat dissipation and can result in thermal overload. The availability of the system can be increased by regular checks and cleaning of the motors. Please ensure access to the motors for maintenance purposes.

## 6.2.5 Encoder

Table 6: MKE - Technical data of encoder

Designation	Symbol	Unit	Encoder			
			A	B	C	D
Protocol			Hiperface	EnDat 2.1	Hiperface	EnDat 2.1
Encoder design			Singleturn abso- lute	Singleturn abso- lute	Multiturn abso- lute	Multiturn abso- lute
Distinguishable rotations			1	1	4,096	4,096
Encoder resolution			12 bit	13 bit	12 bit	13 bit
Number of impulse			128	2,048	128	2,048
System accuracy		"	± 120	± 20	± 120	± 20
Incremental signals			1V <sub>ss</sub>			
Max. current consumption	I <sub>Encoder</sub>	mA	60	150	60	250
Supply voltage	V <sub>CCEncoder</sub>	V	7 ... 12	3.6 ... 14	7 ... 12	3.6 ... 14

### Optical encoder Singleturn option A, B

The encoders allow an absolute, indirect position recording within **one** mechanical rotation. The encoders replace additional separate incremental encoders on the motor.

**Remark:** After a voltage drop or after the first POWER ON, the axis must always be moved to its reference point first.

**Exception:** Applications where the maximum travel is within one mechanical revolution of the motor.

### Optical encoder Multiturn absolute option C, D

The encoders enable absolute, indirect position sensing within **4,096** mechanical revolutions. The encoders replace a separate absolute value encoder at the motor. The absolute axis position at this encoder variant is retained by the battery buffering.

### 6.2.6 Degree of protection

The protection type according to EN 60529:1991 + A1:2000 + A2:2013 is determined by the abbreviation IP (International Protection) and two code numbers for the degree of protection. The first reference number stands

for the degree of protection against contact and ingress of foreign bodies, the second one stands for the degree of protection against ingress of water.

Standard motors (specification according to type plate)

- IP65 with shaft sealing ring

### 6.2.7 Output shaft, balancing and extension elements

#### Shaft end

Table 7: Options according to type code

Shaft	Type
Smooth	G
Keyway, with shaft sealing ring	P

#### Smooth shaft

Cylindrical shaft end according to DIN 748-3 with frontal centering hole with "DS" thread according to DIN 332-2.

The standard design for a non-positive shaft-hub connection without play and excellent smooth running. Use clamping sets, pressure sleeves or clamping elements for coupling the machine elements to be driven.

## Shaft with keyway

Cylindrical shaft end according to DIN 748-3 with frontal centering hole with "DS" thread according to DIN 332-2 and keyway.

The keyway design allows form-locking transmission of torques with constant direction and low requirements on the shaft-hub connection.

The machine elements to be driven have to be secured in axial direction via the centering hole.

Table 8: Keys and centering hole for MKE motors

Type	Key DIN 6885-A	Centering hole DIN 332 Part 2
MKE037	3×3×16	DS M3
MKE047	5×5×20	DS M5
MKE098	8×8×40	DS M8
MKE118	10×8×45	DS M10

**Remark:** Keys are not included in the scope of delivery.

We recommend regular visual inspections on shaft sealing rings. Depending on operating conditions, signs of wear may appear after 5,000 operating hours. If necessary, replace the shaft sealing rings. **Repairs must be carried out by Rexroth Service.**

## Balancing

MKE motors are balanced with the "complete key".

## Attachment of drive elements

Observe the notes about mounting drive elements.

## Explosion protection

Before mounting drive elements, the suitability of the entire system and all components must be checked in accordance with the country-specific requirements for explosion protection and complied with during operation. Selecting of all mounting components underlies the sole responsibility of the plant manufacturer or operator.

### ▲ WARNING

#### Explosion hazard and danger to life, or substantial property damage!

The totality of a motor-machine combination must comply with the specifications for explosion protection.

Please observe the notes within the product documentation of the used components when projecting and during operation.

Gearboxes with approvals for use in hazardous areas for the attachment to MKE motors are delivered by Rexroth neither separately nor mounted on motors.

The mounting of gearbox in hazardous areas, including selection and certification underlies the sole responsibility of the plant manufacturer or operator.

### ▲ CAUTION

#### Ingressing fluid may damage the motor!

Fluids (e.g., cooling lubricants, gear oil, etc.) may not be present at the output shaft.

When attaching gearboxes, only use gearboxes with a closed (oil-tight) lubrication system. Gearbox oil should not be in permanent contact with the shaft sealing ring of the motors.

## Overdetermined bearing

When installing drive elements, avoid overdetermined bearing as impermissibly high bearing reactions can be generated due to unfavorable tolerance ratios.

**Remark:** If overdetermined arrangement of bearings cannot be avoided, please contact Bosch Rexroth.

## Couplings

The machine construction and the drive elements used must be carefully adapted to the motor type so as to make sure that the load limits of the shaft and the bearing are not exceeded.

**Remark:** When extremely stiff couplings are attached, the revolving radial force may cause an impermissibly high load on the shaft and bearing.

### Bevel gear pinion or helical drive pinion

Due to thermal expansion, the DE side of the drive shaft can be displaced by up to 0.6 mm in relation to the motor housing. If helical drive pinions or bevel gear pinions directly attached to the output shaft are used, this change in the lengths will lead to

- a shift in the position of the axis, if the driving pinions are not axially fixed on the machine side.
- a thermally dependent component of the axial force, if the driving pinions are axially fixed on the machine side. This causes the risk of exceeding the maximum permissible axial force or of the gear backlash increasing to an impermissible degree.
- Damage of the NDE bearing by exceeding the maximum permissible axial force.

**Remark:** It is recommended to use drive elements with integrated bearings and mount them on the motor shaft via axially compensating couplings.

## 6.2.8 Holding brake

### ▲ WARNING

**Danger to life or high damage to property, ignition and explosion hazard due to inappropriate use!**

In order to prevent danger due to ignitable gases or explosive dust-air mixtures in the vicinity of the motors, the user must make sure that the holding brake does not present a source of ignition in the normal service. For this reason, the holding brake must never be used outside the design parameters and operating conditions!

- Any commissioning and maintenance works must only be carried out in non-explosive environments.
- The brakes must be designed so as to fulfill their function in normal service, if they are installed and used as intended.
- The holding brake integrated in the motor must only be used at standstill and never as EMERGENCY STOP brake to stop the motor, see P-0-0119, Optimal shutdown (Indra-Drive firmware - functional description).
- The holding brake must not be used to brake or stop the motor or coupled loads from higher speeds or velocities.

MKE motors can optionally be provided with permanent magnet brakes. The backlash-free holding brakes are operated according to the “electrically-released” principle (closed-circuit principle) and open upon applying the switching voltage.

- Number of operating cycles  $\geq 5,000,000$
- The holding brakes with emergency stop function are intended to secure motor shafts at standstill (normal operation). **The holding brakes are no operation brakes to decelerate motors in operation from speed.**
- Emergency stop situations are not a normal operation.

- In case of an emergency stop or voltage drop, the brake operation is only allowed to a limited extend. Up to 500 breaking cycles from speed 3000 1/min can be performed, whereas the maximum switched energy per emergency stop of the brake must not be exceeded. The number of brake applications per hour is 20, whereas a uniform scheduling is a precondition. Specifications about the max. switched energy per emergency stop on request.
- Idle time after an emergency stop before restarting  $\geq 3$  minutes.

**⚠ CAUTION****Malfunctions due to wear**

Impermissibly high wear due to breaking from speed by exceeding the specified emergency stop properties.

Ensure the functionality of the brake in normal operation, due to voltage control, current monitoring, cyclic control of the brake holding torque, for example.

The rated voltage to apply the brakes is 24 V DC  $\pm 10\%$ .

The voltage supply of the holding brake has to be designed so as to guarantee under the worst installation and operation conditions that a sufficient voltage **24 V DC  $\pm 10\%$**  is available at the motor in order to release the holding brake.

The voltage drop  $\Delta U$  on the brake supply can approximately be calculated for copper conductors using the following formula:

$$\Delta U = \rho_{Cu} \cdot \left( \frac{2 \cdot l}{q} \right) \cdot I_N$$

Fig. 4: Voltage drop of brake supply

$\Delta U$  Voltage drop [V]

$\rho_{Cu}$  Specific resistance of copper [ $\Omega \cdot \text{mm}^2/\text{m}$ ]

$l$  Cable length [m]

$q$  Conductor cross-section [ $\text{mm}^2$ ]  
 $I_N$  Rated current [A]

**⚠ CAUTION****Malfunction in case of exceeded tolerance of the rated voltage (switching voltage)**

For safe switching of the holding brake, a rated voltage of **24 V DC  $\pm 10\%$**  is required at the motor.

Ensure correct dimensioning of the supply wires (wire length and cross-section) for the holding brake.

The control voltage can be reduced using the energy saving function after safely releasing the brake, see [Chapter "Energy saving function for holding brakes"](#) on page 40.

The holding brake in the motor is intended for direct connection to the Bosch Rexroth controller.

The protective circuit for switching holding brakes (inductive load) is not integrated in the MKE motors; in Bosch Rexroth drive systems it is integrated in the control units.

## Technical data holding brakes

Table 9: Holding brake data (optional)

Type	Holding torque	Rated voltage 1)	Rated current	Maximum connection time	Maximum disconnection time
	$M_4$ [Nm]	$U_N$ [V]	$I_N$ [A]	$t_1$ [ms]	$t_2$ [ms]
MKE037B-__-1-__	1.00	24	0.40	3	4
MKE047B-__-1-__	2.20	24	0.34	14	28
MKE098B-__-1-__	11.00	24	0.71	13	30
MKE118B-__-1-__	32.00	24	0.93	15	115
MKE118D-__-3-__	70.00	24	1.29	53	97

1) Tolerance  $\pm 10\%$

### Energy saving function for holding brakes

#### Decrease brake voltage

The control voltage of the holding brake in MKE holding brakes can be reduced after executing the switching operation "Open brake" by using suitable control modules (e.g. IndraDrive brake control module HAT02.1-003). By decreasing the control voltage, energy can be saved of up to 50% and the self-heating of the motor can be reduced.

To decrease the control voltage of MKE holding brakes, the following conditions apply:

- Maximum decrease of control voltage to  $U_N \geq 17$  V DC at the motor.
- Waiting time after releasing the holding brake is at least 200 ms
- Decreasing the control voltage by voltage control or pulse width modulation with a PWM cycle frequency  $\geq 4$  kHz  
Decreasing the controlled voltage or PWM cycle frequency of the control voltage  $\geq 4$  kHz
- Ensure the functionality of the holding brake.

**Remark:** Refer to the instructions in the control module documentation.

Refer to the notes for dimensioning of the cable length and cable cross-section of brake cables.

### Safety and personal protection

The permanent magnet brakes of the MKE motors are not safety brakes, since a holding torque reduction can occur due to uninfluenceable disturbance factors. Especially for use in vertical axes.

#### **▲ WARNING**

#### **Grievous bodily harm due to dangerous movements from falling or dropping axes!**

Secure vertical axes against dropping or sinking after switching off by e.g.:

- Mechanical locking of the vertical axis
- External brake, arrestor, clamping device.
- Weight compensation of the axes

The holding brake itself is not suitable for personal protection. Ensure protection of persons by superordinate fail-safe measures, like block danger zones via safety fences.

For European countries, additionally comply with the following standards and guidelines, e.g.

- EN ISO 13849-1:2015 Safety of machinery - Safety-related parts of control systems - Part 1: General principles for design (ISO 13849-1:2015), EN ISO 13849-2:2012

- Safety of machinery. Safety-related parts of control systems. General principles for design
- Information sheet no. 005 "Gravity-loaded axes (vertical axes)" published by: DGUV Fachbereich Holz und Metall (German Employer's Liability Insurance Association Wood and Metal)

Determine the complete safety requirements valid for the specific case of application and observe them during plant design. Comply with all applicable national regulations!

### Functionality test

#### ▲ WARNING

#### Danger of explosion at maintenance work and check operation

Do maintenance work only outside of hazardous areas.

Ensure that no hazardous gas or dust atmosphere exists during grind in procedures.

That is why the function and the holding brakes have to be checked in regular intervals and malfunctions must be removed in an appropriate period.

The braking effect can be reduced by:

- Corrosion on friction surfaces, vapor and sediment
- Over voltages and too high temperatures
- Wear (increasing the air gap between armature and pole)

The holding brake functionality can be checked mechanically by hand or automatically by means of the software function.

### Manually check holding torque (M4)

1. ➔ De-energize the motor and ensure it cannot be restarted.

2. ➔ Measure the transferable holding torque (M4) of the holding brake with a torque wrench.

### Check holding torque (M4) using the software function

For Bosch Rexroth drive controller

- ➔ Start the P-0-0541, C2100 Command Holding system check in drive controller. The efficiency of the holding brake and the opened state are checked by starting the routine.
  - ➔ If the holding torque (M4) is **not achieved**, the resurfacing routine can be used to reconstitute the holding torque. If you have any questions about grind in parameters, contact Bosch Rexroth service.

### 6.2.9 Vibration behavior

The oscillation behavior corresponds to oscillating quantity level A according to EN IEC 60034-14:2018 up to the rated speed.

### 6.2.10 Bearing

The motors are equipped with a deep-groove ball bearing with high-temperature grease for prelubrication.

#### Bearing service life

The bearing lifetime is an important criterion for the availability of motors. The operating conditions influence the bearing service life  $L_{10h}$  considerably.

The following boundary conditions apply to the bearing service life  $L_{10h}$ :

- Operation within the specified permissible loads (radial and axial force)
- Operation within the permissible ambient conditions (temperature range 0 ... 40 °C, vibration, and so on).
- Operation within the thermally permissible operating characteristic curve

The bearing lifetime also depends on the service life of the grease. A calculated grease service life was used for the mentioned specifications, taking into consideration the following boundary conditions.

- Horizontal installation
- Low vibration and impact loads
- No oscillating bearing movement < 180°
- Mean speed according to the following table

Table 10: Mean speed - basis of calculated grease service life

Type	Mean speed
MKE037	≤ 3,500 1/min
MKE047	≤ 3,500 1/min
MKE098	≤ 3,000 1/min
MKE118	≤ 2,000 1/min

The following standard values apply under the specified preconditions:

$L_{10h} = 30.000$  h, in case of utilization after S1-60K and max. load factor 95% during the runtime.

ⓘ **Remark:** When exceeding or not complying with these conditions, a reduced service life is to be expected.

### Explanation of radial and axial force

During operation, both radial and axial forces act upon the motor shaft and the motor bearing. The permissible radial force  $F_R$  in distance  $x$  from the shaft shoulder and the mean speed is specified in the radial force diagrams.

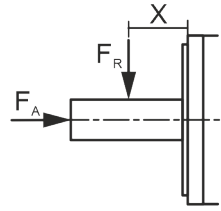

Fig. 5: Point of action of radial force  $F_R$  and axial force  $F_A$

The axial force values are the minimum permissible axial forces  $F_A$  without limitations. A detailed dimensioning is only possible if more boundary conditions are known:

- Occurring radial force and axial force with force application point
- Installation position (horizontal, vertical with the shaft end pointing to the top or bottom)
- Mean speed

For radial force diagrams, refer to the technical data

### 6.2.11 Frame size, installation type

The motors can be installed horizontally and vertically with the shaft end pointing to the top or bottom. The mounting variants comply with the IM code according to EN 60034-7 for design and installation type.

#### Code I / Code II (EN 60034-7:1993 + A1:2001)

IM B5 / IM 3001		Flange attachment on the drive side of the flange
IM V1 / IM 3011		Flange attachment on the drive side of the flange, drive side facing down
IM V3 / IM 3031		Flange attachment on the drive side of the flange, drive side facing up

Avoid liquid at the drive shaft or the shaft sealing ring in case of vertical installation according to IM V3.

### 6.2.12 Coating

One-layer standard varnish (1K), waterbased, in conductive form, RAL9005 jet black, nominal thickness 40 µm.

**▲ WARNING**

**Danger of explosion due to improper change of the surface characteristics.**

An additional varnish on motors for hazardous areas is not allowed in order not to negatively influence the surface characteristics (like e.g. insulation resistance, electrostatic charging).

### 6.2.13 Noise emission

The typical sound pressure level Lp(A) is specified for the speed range 0 rpm up to the rated speed in the chapter "Technical data". The installation situation affects the noise emission.

## 7 Transport and storage

### 7.1 Storage

Store the motors in their original packaging in a dry, dust-free, vibration-free and light-protected place without direct solar radiation. Please observe classes 1K21, 1B1, 1C1, 1S10, 1M11 specified for storage according to EN IEC 60721-3-1:2018.

Deviations and enhancements according to the following table must be observed.

Table 11: Deviations and enhancements of classification acc. to EN IEC 60721-3-1:2018

Bearing	
Ambient temperature	-25 ... +55 °C
Relative air humidity	5 ... 75 %
Absolute air humidity	1 ... 29 g/m³
Direct solar radiation	Not permitted

Bearing	
Shock load	→ Chapter 7.3 "Shock load during transport und storage" on page 44

Do not remove factory-fitted transport protection devices such as dust protection, shaft protection, dummy plugs when storing the motors. Keep the transport protection devices for later use.

**NOTICE**

**Damage due to moisture and humidity!**

- Protect the products from dampness and corrosion.
- Store them only in rainproof and dry rooms.

Additional measures have to taken upon commissioning to ensure smooth functioning – irrespective of the storage time which may be longer than the warranty period of our products. Warranty extension is not a consequence.

Table 12: Measures before commissioning motors that have been stored over a prolonged period of time

Storage time / months	Measures for commissioning
> 1	<ul style="list-style-type: none"> <li>• Visual inspection of all parts to be damage-free</li> </ul>
> 12	<ul style="list-style-type: none"> <li>• Resurface the holding brake</li> <li>• Check the electric contacts to verify that they are free from corrosion</li> </ul>
> 60	<ul style="list-style-type: none"> <li>• Let the motor run in without load for one hour at 800 ... 1,000 rpm</li> <li>• Measure insulation resistance. Dry the winding at a value of &lt; 1kOhm per volt rated voltage.</li> </ul>
	<ul style="list-style-type: none"> <li>• Replace bearings</li> <li>• Replace encoder</li> </ul>

### 7.2 Transport

The motors must be transported in their original package taking classes 2K11, 2B1, 2C1, 2S5, 2M4 specified acc. to EN IEC 60721-3-2:2018.

Deviations and enhancements according to the following table must be observed.

Table 13: Deviations and enhancements of classification (EN IEC 60721-3-2:2018)

Transport	
Ambient temperature	-25 ... +70 °C
Relative humidity	5 ... 75 %
Shock load	→ Chapter 7.3 "Shock load during transport und storage" on page 44

### 7.2.1 Instructions on machine transport

Do not remove factory-fitted transport protection devices such as dust protection, shaft protection, dummy plugs until the motors will be used. Keep the transport protection devices for later use.

#### NOTICE

#### Never touch the connection points of electrostatic sensitive devices!

- Mounted components (e.g. temperature sensors, encoder) can contain parts susceptible to electrical discharge. Observe the ESD safety measures.

#### ▲ WARNING

#### Risk of injury and material damage due to improper handling during transport!

- Only use hoisting gear suited for the weight of the motors. Use lifting sling belts or lifting eye bolts. Secure the lifting eye bolts before use.  
Never walk under hanging loads.  
Never lift the motor on the shaft.
- Use suitable protective equipment and protective clothing during transport, and wear safety shoes.

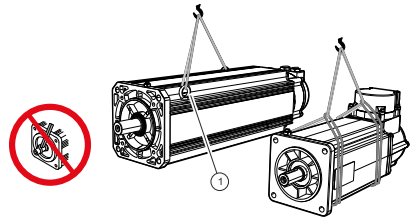

Fig. 6: Lifting and transporting motors

- Before transporting the motor, determine the weight of the motor. For more details about motor weight, please refer to the type plate or the project planning manual (Technical data).
- Adjust the carrying capacity of the lifting device to the motor weight.
- If provided by the manufacturer, all lifting eye bolts must be used and tightened before use.
- Avoid increased transport vibrations.
- Remove any existing transport locks prior to commissioning and keep them.

## 7.3 Shock load during transport und storage

Function-impairing effects are avoided as long as the specified limits are complied with.

Table 14: Permissible shock load for MKE motors

Frame size	Maximum allowed shock load (11 ms)	
	Axial	Radial
MKE037	10 m/s <sup>2</sup>	1000 m/s <sup>2</sup>
MKE047	10 m/s <sup>2</sup>	1000 m/s <sup>2</sup>
MKE098	10 m/s <sup>2</sup>	300 m/s <sup>2</sup>
MKE118	10 m/s <sup>2</sup>	200 m/s <sup>2</sup>

## 8 Assembly

### 8.1 Flange assembly

#### NOTICE

#### Motor damage due to ingress of liquids!

Liquid which exists over a longer period on the shaft sealing ring of the output shaft can ingress into the motor and cause damage.

- Ensure that liquid cannot be present at the output shaft.
- Do not mount any open gearboxes (gearboxes that are not hermetically sealed).

Use all motor mounting holes to mount the motor safely to the machine. For details on mounting holes, please refer to the dimension sheets.

- If coupling is direct, ensure that the support is plane and the orientation is precise.
- Avoid pinching or jamming the centering collar on the motor side.
- Avoid damaging the receptacle fit on the plant side.
- Use screws and washers for flange assembly according to [Chapter 6.2.2 "Mechanical interface"](#) on page 33.

### 8.2 Assemble transmission elements

#### NOTICE

#### Motor damage due to strikes onto the motor shaft

Do not strike the shaft end and do not exceed the allowed axial and radial forces of the motor.



Fit and pull off the transmission elements such as pulleys and couplings only with suitable equipment; heat them, if necessary.

- Avoid inadmissible belt tensions. Please consider the allowed radial and axial forces in the project planning manuals.
- The balancing state of transmission elements must comply with the full-key balancing of the motors.

#### Fitting

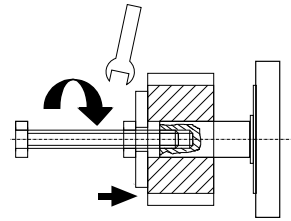

Fig. 7: Fitting the transmission element

- Use the centering hole for fitting transmission elements. For details on centering holes, please refer to the specifications.
- Heat the transmission element, if necessary.

## 8.3 Electrical connection

### 8.3.1 Electrical connection general notes

#### ⚠ WARNING

#### Risk of explosion due to improper handling during motor connection!

Make sure that the motor is only connected in de-energized state and a non-explosive atmosphere.

Before working on the system, always use a suitable measuring device (e.g. multimeter) to check whether any parts of the system are still under residual voltage (e.g. caused by residual energies of capacitors in filters and drive units etc.) their discharge times are to be waited for.

The connection between the protective conductor terminal and the operating ground must be made before any other connections.

The connection or terminal points to or on the control unit must be located outside the potentially explosive atmosphere or must be approved for use in potentially explosive atmospheres.

#### ⚠ WARNING

#### Danger! Electric voltage! Operations in the vicinity of live parts are extremely dangerous.

- Work required on the electric system may only be carried out by skilled electricians. Tools for electricians (VDE tools) are absolutely necessary.
  - Isolate (even auxiliary circuits).
  - Secure against reactivation.
  - Ensure de-energization.
  - Ground and short-circuit.
  - Cover or shield any adjacent live parts.

#### ⚠ WARNING

#### High electric voltage! Danger to life, risk of injury by electric shock.

While the rotor is rotating, motors with permanent magnet excitation create a voltage > 60 V at the motor connections.

Any work may only be carried out while the motor is at standstill.

Never connect or disconnect plug connectors under load!

#### NOTICE

#### Never touch the connection points of electrostatic sensitive devices!

- Mounted components e.g. temperature sensor, encoder) can contain parts susceptible to electrical discharge (ESD).  
Observe ESD safety measures.

The electrical connection of MKE motors (EU) consists of the following components:

- Power connection (terminal box)
- Encoder connection (terminal box)
- Equipotential bonding conductor (ground conductor)



Power and encoder connection cables are connected within the ATEX terminal box. The openings for the cable entries (Ex-KLE) are closed with dummy plugs on delivery. Use certified Ex cable and line entries (EN 60079-14:2014). The Ex cable and line entries are not included in the scope of delivery.

Mount the cable glands (Ex-KLE) according to the manufacturer's specifications.

All connection variants must comply with the specifications according to EN 60079-14:2014 point 10.6 ff "Additional requirements for type of protection "d" - Flameproof enclosure".

Observe the manufacturer's operating instructions as well as EN 60079-14 and corresponding regional standards.

**Remark:** Only use suitable Ex cable glands (Ex-KLE) in accordance with EN 60079-14:2014 Explosive atmospheres. The manufacturer or machine operator is in the sole responsibility for project planning, selection and installation of electric devices (assembly).

A seal in accordance with EN IEC 60079-0 must be used between the Ex-KLE and the terminal box cover to ensure the necessary IP protection of the motor in accordance with EN 60079-31.

**Remark:** Flat gaskets or O-rings must be used to ensure suitable sealing of the Ex-KLE to the motor housing (IP protection).

Use shielded connection lines. The shield connection -X5 for encoder and power cables is located in the terminal box lid.

The protective conductor connection is made via the protective conductor routed in the power cable in the terminal box of the MKE.

An additional connection of a protective or equipotential bonding conductor is mandatory for Ex motors according to EN IEC 60079-0. MKE must be grounded via the additional connection part (protective earth terminal on the motor flange). Ground terminal cross section see [Chapter 8.3.7 "Ground connection"](#) on page 58.

## Connection thermo controller

The motor temperature can be evaluated via Rexroth drive controllers when MKE motors are used in potentially explosive atmospheres.

For Rexroth drive controllers we recommend to use the current variant c) for temperature evaluation (see [Chapter 6.2.3 "Thermal motor protection"](#) on page 34). That means a functionally tested triggering device (acc. to  $\text{Ex}$  II 2G or  $\text{Ex}$  II 2D) and the two channels connection with the Safety Integrated Function STO on the Rexroth drive controller.

### ▲ WARNING

#### Risk of explosion due to impermissible temperature increase in case of faulty temperature evaluation!

The connections [1] and [2] of the PTC resistor (triplet PTC thermistor) must be connected to a functionally tested triggering device! Depending on the drive controller used, function-tested triggering devices with the  $\text{Ex}$  II 2 G or  $\text{Ex}$  II 2 D designation may be required to evaluate the temperature sensors.

The maximum permissible surface temperature of the MKE motors is  $\leq 135$  °C, which corresponds to temperature class T4. The triplet thermistors installed in the MKE motors, in conjunction with the functionally tested triggering devices or arrangement, ensure reliable and safe overtemperature shutdown.

### 8.3.2 Wiring diagram

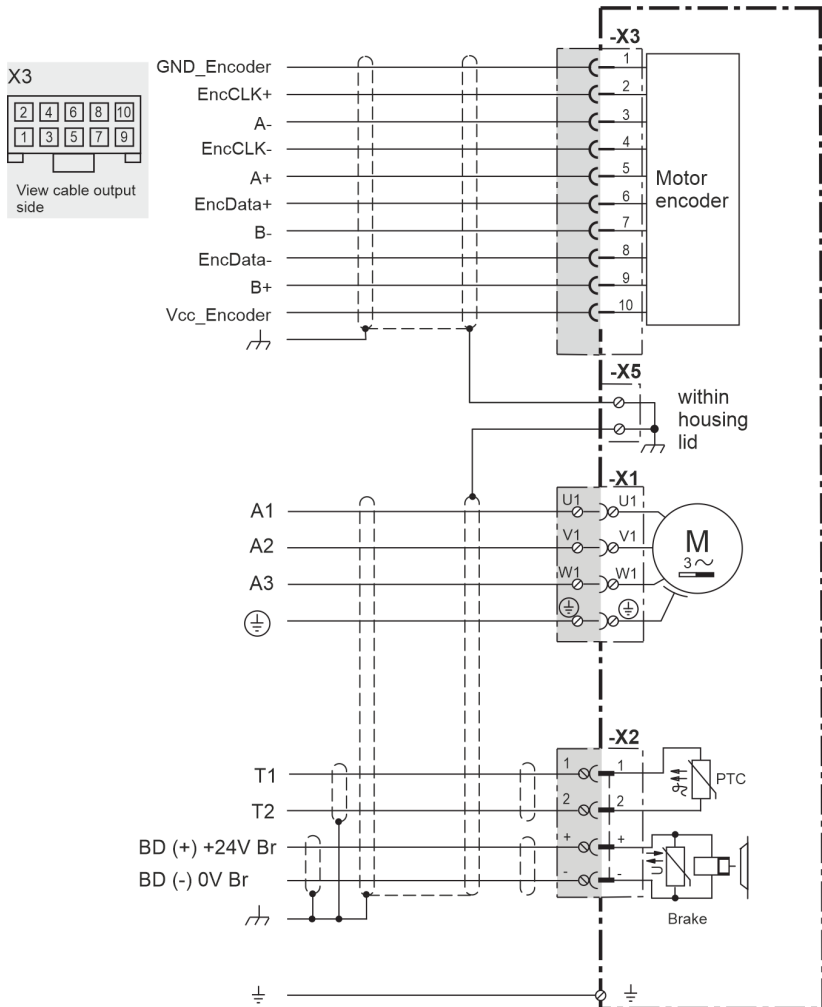

Fig. 8: Connection MKE EU with EnDat2.1

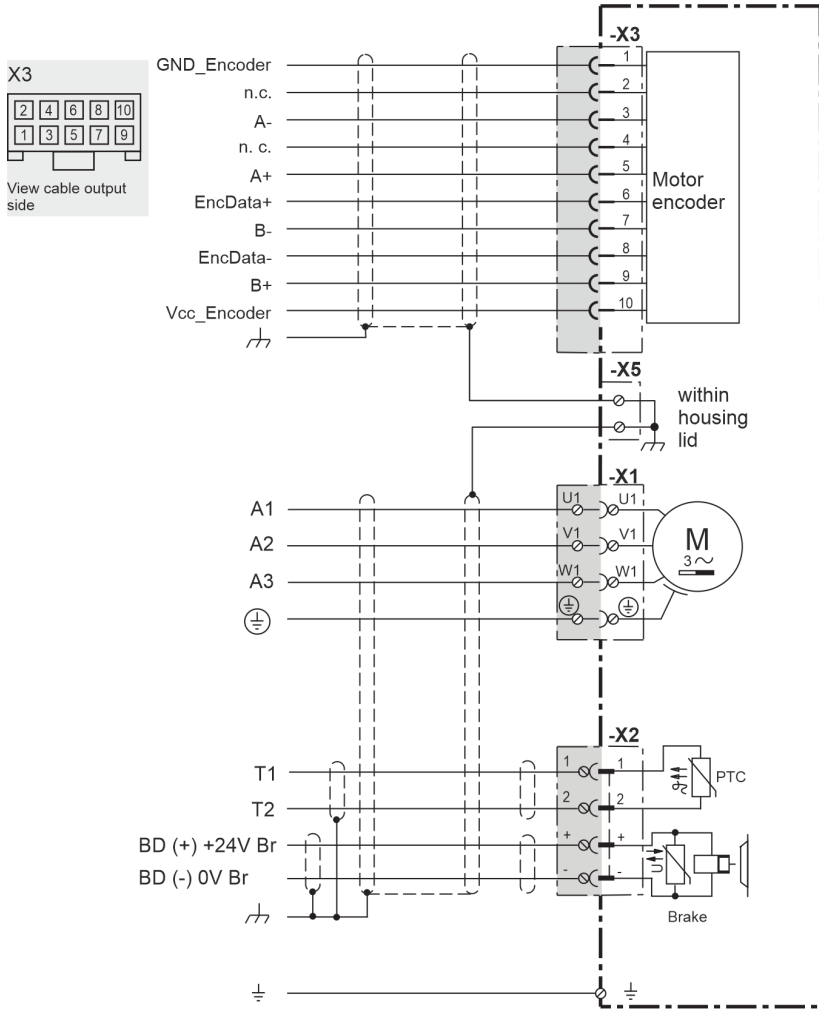
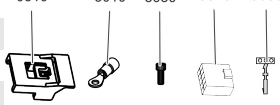

Fig. 9: Connection MKE EU with Hiperface

### 8.3.3 Terminal boxes (MKE037-E) electrical connection

The accessory kit **SUP-M04-MKE0XX** is necessary to connect the motor. The accessory kit is included with the motors at delivery.

Pos	Material number	Designation	Quantity	View
0500	R911400167	DOK-MOTOR-MKE0XX****-ISRS-D0-P	1	0510 3010 3030 3040 3050
0510	R911278283	LOCKING CONNECTOR 2X5 POL.	1	
3010	R911211410	TERMINAL END KQ-M3_/0.25-01.5RD16&	2	
3030	R911282226	CYLINDER HEAD SCREW ISO4762- M5X14-8.8-MK	4	
3040	R911286371	Connector housing 10pol. 87613-005	1	
3050	R911260765	CONTACT KON-EF-0.32/0.52-NNN&	10	

### ▲ WARNING

#### Danger of explosion by using improper cable glands.

- The Ex cable glands and cables must be evaluated, selected and assembled by the machine builder and always in combination with the cables used in accordance with DIN EN 60079-14 "Potentially explosive atmospheres - Planning, selection and installation of electrical systems".

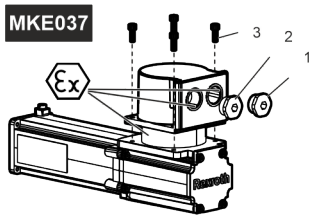

Fig. 10: Electrical connection MKE037 Housing design E

- Remove M20 screw-type blank cap and replace it by Ex cable gland
  - Remove M20 screw-type blank cap and replace it by Ex cable gland
  - Tightening torque 6.3 Nm (use enclosed screws 3030)
- Ex Ignition gap, assembly damage not permissible

#### Notes for assembly

- In the case of mounting procedures, flame-proof gaps must be opened and jointed. Avoid damages on the ignition gaps. Do not remove existing mounting grease, leave it on the O-rings as delivered. Work in a clean environment.
- In the case of mounting damages on the flameproof joints, let the motor be repaired with origin components by the Rexroth service.
- For mounting, use the delivered pre-coated screws.
- Use shielded connection cables.
- Use Ex cable glands.

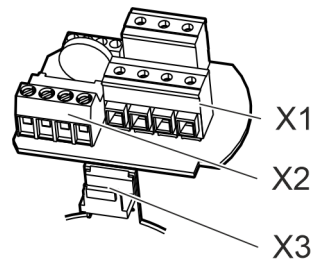

Fig. 11: MKE037 EU Clamps

#### Assembly -X1

Pin	Signal
1	U1
2	V1
3	W1
4	PE

## Technical data -X1

Clamping range	0.5 ... 4 mm <sup>2</sup>
Wire stripping length	5 mm, use wire end ferrules
Clamping screws (size)	M3
Tightening torque clamping screws	0.5 Nm

## Assembly -X2

Pin	Signal
1	T1
2	T2
3	BR+
4	BR-

## Technical data -X2

Clamping range	2.5 mm <sup>2</sup>
Wire stripping length	5.5 mm, use wire end ferrules
Clamping screws (size)	M3
Tightening torque clamping screws	0.5 Nm

## Notes about assembly:

- Insert the plug terminal X2 onto the printed circuit board and observe correct latch of the plug-in interlock.

## Assembly -X3

Pin	Signal [Encoder A, C]	Signal [Encoder B, D]
1	ENC_ Encoder	ENC_ Encoder
2	n.c.	ENC_CLK-
3	A-	A-
4	n.c.	ENC_CLK+
5	A+	A+
6	EncData+	EncData+
7	B-	B-
8	EncData-	EncData-
9	B+	B+
10	VCC_ Encoder	VCC_ Encoder

## Technical data -X3

Contact	R911260765, Bosch Rexroth
Crimping area	0.32 ... 0.52 mm <sup>2</sup>
Wire stripping length	3 mm
Crimping tool	R911262293, Bosch Rexroth



Fig. 12: MKE-X3 Pin assembly

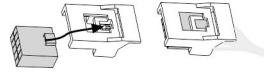

Fig. 13: MKE-X3 Plug-in interlock

## Notes about assembly:

- A hand crimping tool to handle the clamp terminal X3 can be ordered at Bosch Rexroth. **Order number: R911262293.**
- Assemble the contacts within X3 connector housing as described in the following picture.
- Assemble the plug-in interlock (0510) on the connector housing X3.
- Insert the plug terminal X3 onto the printed circuit board and observe correct latch of the plug-in interlock.

## Assembly shield connection

## Technical data terminal ends





Terminal end M3	R911211410, Bosch Rexroth
Crimping area	0.25 ... 1.5 mm <sup>2</sup>
Wire stripping length	5 mm
Crimping tool	Standard
Tightening torque	1.3 Nm (M3 screw within housing lid)

## Notes about assembly:

- Use terminal ends to connect the shield connection to the motor housing.

## 8.3.4 Terminal box (MKE047-E) electrical connection

The accessory kit **SUP-M04-MKE0XX** is required to connect the motors. The accessory kit is included with the motors at delivery.

Pos	Material number	Designation	Quantity	View
0500	R911400167	DOK-MOTOR*-MKE0XX****-ISRS-D0-P	1	0510 3010 3030 3040 3050
0510	R911278283	LOCKING CONNECTOR 2X5 POL.	1	
3010	R911211410	TERMINAL END KQ-M3_/0.25-01.5RD16&	2	
3030	R911282226	CYLINDER HEAD SCREW ISO4762- M5X14-8.8-MK	4	
3040	R911286371	Connector housing 10pol. 87613-005	1	
3050	R911260765	CONTACT KON-EF-0.32/0.52-NNN&	10	

### ▲ WARNING

#### Danger of explosion by using improper cable glands.

- The Ex cable glands and cables must be evaluated, selected and assembled by the machine builder and always in combination with the cables used in accordance with DIN EN 60079-14 "Potentially explosive atmospheres - Planning, selection and installation of electrical systems".

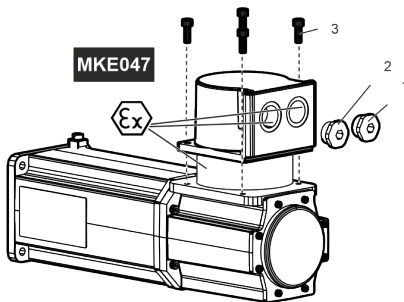

Fig. 14: Electric connection MKE047 housing design E

- Remove M20 screw-type blank cap and replace it by Ex cable gland
  - Remove M20 screw-type blank cap and replace it by Ex cable gland
  - Tightening torque 6.3 Nm (use enclosed screws 3030)
- Ex Ignition gap, assembly damage not permissible

#### Notes for assembly

- In the case of mounting procedures, flameproof gaps must be opened and jointed. Avoid damages on the ignition gaps. Do not remove existing mounting grease, leave it on the O-rings as delivered. Work in a clean environment.
- In the case of mounting damages on the flameproof joints, let the motor be repaired with origin components by the Rexroth service.
- For mounting, use the delivered pre-coated screws.
- Use shielded connection cables.
- Use Ex cable glands.

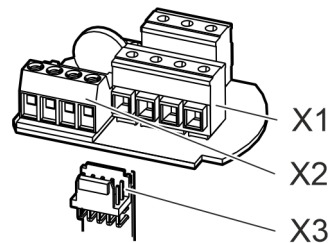

Fig. 15: MKE047 EU clamps

#### Assembly-X1

Pin	Signal
1	U1
2	V1
3	W1
4	PE

## Technical data -X1

Clamping range	0.5 ... 4 mm <sup>2</sup>
Wire stripping length	5 mm, use wire end ferrules
Clamping screws (size)	M3
Tightening torque clamping screws	0.5 Nm

## Assembly -X2

Pin	Signal
1	T1
2	T2
3	BR+
4	BR-

## Technical data -X2

Clamping range	2.5 mm <sup>2</sup>
Wire stripping length	5.5 mm, use wire end ferrules
Clamping screws (size)	M3
Tightening torque clamping screws	0.5 Nm

## Notes about assembly:

- Insert the plug terminal X2 onto the printed circuit board and observe correct latch of the plug-in interlock.

## Assembly -X3

Pin	Signal [Encoder A, C]	Signal [Encoder B, D]
1	ENC_ Encoder	ENC_ Encoder
2	n.c.	ENC_CLK-
3	A-	A-
4	n.c.	ENC_CLK+
5	A+	A+
6	EncData+	EncData+
7	B-	B-
8	EncData-	EncData-
9	B+	B+
10	VCC_ Encoder	VCC_ Encoder

## Technical data -X3

Contact	R911260765, Bosch Rexroth
Crimping area	0.32 ... 0.52 mm <sup>2</sup>
Wire stripping length	3 mm
Crimping tool	R911262293, Bosch Rexroth



Fig. 16: MKE-X3 Pin assembly

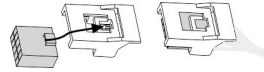

Fig. 17: MKE-X3 Plug-in interlock

## Notes about assembly:

- A hand crimping tool to handle the clamp terminal X3 can be ordered at Bosch Rexroth. **Order number: R911262293.**
- Assemble the contacts within X3 connector housing as described in the following picture.
- Assemble the plug-in interlock (0510) on the connector housing X3.
- Insert the plug terminal X3 onto the printed circuit board and observe correct latch of the plug-in interlock.

## Assembly shield connection

## Technical data terminal ends





Terminal end M3	R911211410, Bosch Rexroth
Crimping area	0.25 ... 1.5 mm <sup>2</sup>
Wire stripping length	5 mm
Crimping tool	Standard
Tightening torque	1.3 Nm (M3 screw within housing lid)

## Notes about assembly:

- Use terminal ends to connect the shield connection to the motor housing.

## 8.3.5 Terminal boxes (MKE098-E) electrical connection

The accessory kit **SUP-M04-MKE0XX** is necessary to connect the motor. The accessory kit is included with the motors at delivery.

Pos	Material number	Designation	Quantity	View
0500	R911400167	DOK-MOTOR*-MKE0XX****-ISRS-D0-P	1	0510 3010 3030 3040 3050
0510	R911278283	LOCKING CONNECTOR 2X5 POL.	1	
3010	R911211410	TERMINAL END KQ-M3_/0.25-01.5RD16&	2	
3030	R911282226	CYLINDER HEAD SCREW ISO4762- M5X14-8.8-MK	4	
3040	R911286371	Connector housing 10pol. 87613-005	1	
3050	R911260765	CONTACT KON-EF-0.32/0.52-NNN&	10	

### ▲ WARNING

#### Danger of explosion by using improper cable glands.

- The Ex cable glands and cables must be evaluated, selected and assembled by the machine builder and always in combination with the cables used in accordance with DIN EN 60079-14 "Potentially explosive atmospheres - Planning, selection and installation of electrical systems".

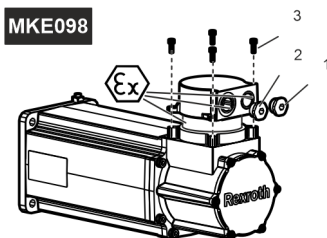

Fig. 18: Electrical connection MKE098 Housing design E

- Remove M20 screw-type blank cap and replace it by Ex cable gland
  - Remove M20 screw-type blank cap and replace it by Ex cable gland
  - Tightening torque 6.3 Nm (use enclosed screws 3030)
- Ex Ignition gap, assembly damage not permissible

#### Notes for assembly

- In the case of mounting procedures, flameproof gaps must be opened and jointed. Avoid damages on the ignition gaps. Do not remove existing mounting grease, leave it on the O-rings as delivered. Work in a clean environment.
- In the case of mounting damages on the flameproof joints, let the motor be repaired with origin components by the Rexroth service.
- For mounting, use the delivered pre-coated screws.
- Use shielded connection cables.
- Use Ex cable glands.

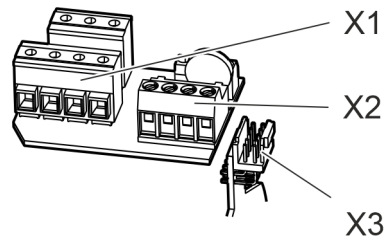

Fig. 19: MKE098 Clamps

#### Assembly -X1

Pin	Signal
1	U1
2	V1
3	W1
4	PE

## Technical data -X1

Clamping range	0.5 ... 4 mm <sup>2</sup>
Wire stripping length	5 mm, use wire end ferrules
Clamping screws (size)	M3
Tightening torque clamping screws	0.5 Nm

## Assembly -X2

Pin	Signal
1	T1
2	T2
3	BR+
4	BR-

## Technical data -X2

Clamping range	2.5 mm <sup>2</sup>
Wire stripping length	5.5 mm, use wire end ferrules
Clamping screws (size)	M3
Tightening torque clamping screws	0.5 Nm

## Notes about assembly:

- Insert the plug terminal X2 onto the printed circuit board and observe correct latch of the plug-in interlock.

## Assembly -X3

Pin	Signal [Encoder A, C]	Signal [Encoder B, D]
1	ENC_ Encoder	ENC_ Encoder
2	n.c.	ENC_CLK-
3	A-	A-
4	n.c.	ENC_CLK+
5	A+	A+
6	EncData+	EncData+
7	B-	B-
8	EncData-	EncData-
9	B+	B+
10	VCC_ Encoder	VCC_ Encoder

## Technical data -X3

Contact	R911260765, Bosch Rexroth
Crimping area	0.32 ... 0.52 mm <sup>2</sup>
Wire stripping length	3 mm
Crimping tool	R911262293, Bosch Rexroth



Fig. 20: MKE-X3 Pin assembly

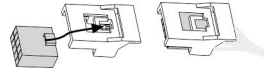

Fig. 21: MKE-X3 Plug-in interlock

## Notes about assembly:

- A hand crimping tool to handle the clamp terminal X3 can be ordered at Bosch Rexroth. **Order number: R911262293.**
- Assemble the contacts within X3 connector housing as described in the following picture.
- Assemble the plug-in interlock (0510) on the connector housing X3.
- Insert the plug terminal X3 onto the printed circuit board and observe correct latch of the plug-in interlock.

## Assembly shield connection

## Technical data terminal ends





Terminal end M3	R911211410, Bosch Rexroth
Crimping area	0.25 ... 1.5 mm <sup>2</sup>
Wire stripping length	5 mm
Crimping tool	Standard
Tightening torque	1.3 Nm (M3 screw within housing lid)

## Notes about assembly:

- Use terminal ends to connect the shield connection to the motor housing.

## 8.3.6 Terminal boxes (MKE118-E) electrical connection

The accessory kit **SUP-M04-MKE1XX** is necessary to connect the motor. The accessory kit is included with the motors at delivery.

Pos	Material number	Designation	Quantity	View
0500	R911400168	DOK-MOTOR*-MKE1X****-ISRS-D0-P	1	0510 3010 3030 3040 3050
0510	R911278283	LOCKING CONNECTOR 2X5 POL.	1	
3010	R911211410	TERMINAL END KQ-M3_/0.25-01.5RD16&	2	
3030	R913018334	CYLINDER HEAD SCREW ISO4762-M6X25-8.8-CM&	4	
3040	R911286371	Connector housing 10pol. 87613-005	1	
3050	R911260765	CONTACT KON-EF-0.32/0.52-NNN&	10	

**▲ WARNING**

**Danger of explosion by using improper cable glands.**

- The Ex cable glands and cables must be evaluated, selected and assembled by the machine builder and always in combination with the cables used in accordance with DIN EN 60079-14 "Potentially explosive atmospheres - Planning, selection and installation of electrical systems".

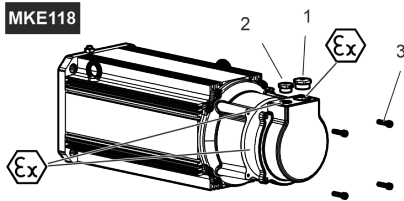

Fig. 22: Electrical connection MKE118 Housing design E

- 1 Remove M25 screw-type blank cap and replace it by Ex cable gland
  - 2 Remove M20 screw-type blank cap and replace it by Ex cable gland
  - 3 Tightening torque 6.3 Nm (use enclosed screws 3030)
- Ex Ignition gap, assembly damage not permissible

Notes for assembly

- In the case of mounting procedures, flameproof gaps must be opened and jointed. Avoid damages on the ignition gaps. Do not remove existing mounting grease, leave it on the O-rings as delivered. Work in a clean environment.
- In the case of mounting damages on the flameproof joints, let the motor be repaired with origin components by the Rexroth service.
- The lid screws are coated. For mounting, use the delivered pre-coated screws. Clean the screw-in threads before screwing in the screws.
- Use shielded connection cables.
- Use Ex cable glands.

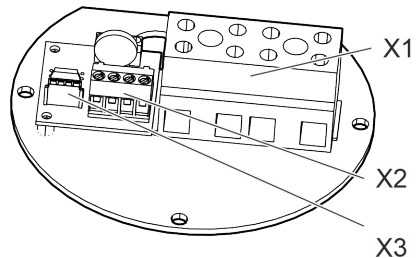

Fig. 23: MKE118 Clamps

**Assembly -X1**

Pin	Signal
1	U1

Pin	Signal
2	V1
3	W1
4	PE

**Technical data -X1**

Clamping range	0.5 ... 10 mm <sup>2</sup>
Wire stripping length	12 mm Use wire end ferrules
Clamping screws (size)	M4
Tightening torque clamping screws	1.8 Nm

**Assembly -X2**

Pin	Signal
1	T1
2	T2
3	BR+
4	BR-

**Technical data -X2**

Clamping range	2.5 mm <sup>2</sup>
Wire stripping length	5.5 mm, use wire end ferrules
Clamping screws (size)	M3
Tightening torque clamping screws	0.5 Nm

**Notes about assembly:**

- Insert the plug terminal X2 onto the printed circuit board and observe correct latch of the plug-in interlock.

**Assembly -X3**

Pin	Signal [Encoder A, C]	Signal [Encoder B, D]
1	ENC_Encoder	ENC_Encoder
2	n.c.	ENC_CLK-
3	A-	A-
4	n.c.	ENC_CLK+
5	A+	A+
6	EncData+	EncData+
7	B-	B-
8	EncData-	EncData-
9	B+	B+
10	VCC_Encoder	VCC_Encoder

**Technical data -X3**

Contact	R911260765, Bosch Rexroth
Crimping area	0.32 ... 0.52 mm <sup>2</sup>
Wire stripping length	3 mm
Crimping tool	R911262293, Bosch Rexroth



Fig. 24: MKE-X3 Pin assembly

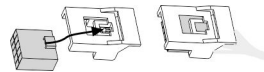

Fig. 25: MKE-X3 Plug-in interlock

**Notes about assembly:**

- A hand crimping tool to handle the clamp terminal X3 can be ordered at Bosch Rexroth. **Order number: R911262293.**
- Assemble the contacts within X3 connector housing as described in the following picture.
- Assemble the plug-in interlock (0510) on the connector housing X3.
- Insert the plug terminal X3 onto the printed circuit board and observe correct latch of the plug-in interlock.

## Assembly shield connection

Technical data terminal ends	
Terminal end M3	R911211410, Bosch Rexroth
Crimping area	0.25 ... 1.5 mm <sup>2</sup>
Wire stripping length	5 mm
Crimping tool	Standard
Tightening torque	1.3 Nm (M3 screw within housing lid)

Notes about assembly:

- Use terminal ends to connect the shield connection to the motor housing.

### 8.3.7 Ground connection

Motors for hazardous areas must be grounded via a separate ground conductor and a grounding conductor within the motor power cable. An additional connection clamp is provided on the motor flange to connect the grounding conductor.

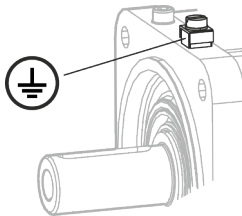

Ground connection	M5 screw
Nominal cross-section	4 mm <sup>2</sup>
	4 mm <sup>2</sup> (fine-wired)
Clamping range	6 mm <sup>2</sup> (single stranded)
Tightening torque	2 Nm

## 9 Commissioning and operation

### 9.1 Safety

#### ▲ WARNING

**High electric voltage! Danger to life, risk of injury by electric shock.**

- Life parts are dangerous.  
Do not open any covers or flange sockets during operation.  
Never connect or disconnect plug connectors under load!

#### ▲ WARNING

**Risk of injury due to rotating motor shaft!**

- Do not remove any covers, machine parts or protection devices during operation.  
Do not enter the range of movement of the machine. Avoid unintended access for persons, due to
  - Safety fences, safety screens or protective covers.
  - Optical sensors

#### ▲ CAUTION

**Thermal danger due to hot surfaces with temperatures over 60 °C during operation**

- Do not touch hot motor surfaces.  
Install protection against contact, if necessary.  
Make sure that no temperature-sensitive components (cables, electronic components, ...) touch hot surfaces.

All persons working with motors (responsible persons, mechanics and planners) must have knowledge, skills and competence according to EN 60079-14:2014.

## 9.2 Ambient conditions during operation

Climatic conditions are defined in classes according to EN IEC 60721. The classes are differentiated in the areas storage, transport and operation. They are based on long-term experiences and take all influencing variables into account, e.g., air temperature and air humidity.

A permanent use of the motors is possible when the specified class 3K22 according to EN IEC 60721-3-3:2019 is observed. Deviations and enhancements according to the following table must be observed.

Table 15: Ambient conditions

Operation	
Installation altitude	0 ... 1,000 m above MSL
Ambient temperature	0 ... +40 °C
Relative humidity	5 ... 95 %
Absolute humidity	1 ... 29 g/m <sup>3</sup>

### 9.2.1 Vibration load during operation

Vibrations are sine-wave oscillations in operation, which vary in their effect on the resistance of the motors depending on their intensity.

The specified limit values are valid for frequencies of 10-2000 Hz during stimulation on the motor flange. Limitations can be necessary for occurring resonances depending on the application and installation situation.

The following limit values apply for MKE motors according to EN 60068-2-6:2008:

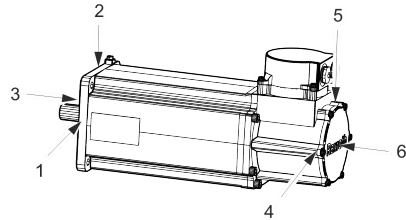

Fig. 26: Vibration load on measuring points

Table 16: Allowed vibration load MKE motors

Direction	Measuring point	Limit value (10-2000 Hz) Encoder A, B, C, D
radial	1, 2 (radial motor flange)	30 m/s <sup>2</sup>
	4, 5 (radial bearing shield)	50 m/s <sup>2</sup>
Axial	3 (axial motor flange)	10 m/s <sup>2</sup>
	6 (axial bearing shield)	25 m/s <sup>2</sup>

The specified values must not be exceeded.

## 9.3 Commissioning

**Commissioning in potentially explosive atmospheres is prohibited until it has been ascertained that the overall system corresponds to the demands and certification conditions for explosion protection.**

MKE motors can only be commissioned with other components (drive controller, control unit).

### Prior to commissioning

Make sure you have the documentations of all used products ready.

Prior to commissioning, ensure that the following requirements are met.

- Ensure that the motor and all participating components of the drive are undamaged.
- Storage time of the motor. Depending on the storage time, take measures to ensure safe operation. Run in bearings, resurface the holding brake, ... See table .

- Make sure that all mechanical and electrical connections (temperature sensor, potential equalization conductor, ...) are properly connected and secured against loosening.
- Ensure that a holding brake voltage of  $24\text{ V} \pm 10\%$  is applied to the motor. If necessary, adjust the voltage.
- Check the proper function of the holding brake.
- **Do not** do the grinding procedure in hazardous ambience.
- Ensure that keys are protected against ejection.

Enable the safety devices and monitoring systems of the machine.

## Commissioning

Once all requirements are met, proceed as follows:

- Commission the drive system according to the instructions of the corresponding product documentation. The respective information can be found in the functional description of the drive controllers.
- Record all measures taken in the commissioning log.

Observe the general and technology-dependent safety instructions in this documentation.

For commissioning of the controllers and control systems, additional steps may be required. The inspection of the functioning and performance of the systems is not object of these Operating Instructions; instead, it is carried out within the framework of the commissioning of the machine as a whole. Comply with the information and instructions of the machine manufacturer.

## 9.4 Operation

During operation, keep the ambient and operation conditions and technical data specified in the operating instruction and project planning manual.

### Checks during operation:

- Pay attention to exceptional noise.
- Pay attention to increased vibrations.
- Check the motor for cleanliness.
- Check the monitoring devices and diagnostic / error messages of the controllers.

**Decommission the drive when deviations from normal operation exist.** For further procedure refer to → Chapter 13 “Eliminate malfunction” on page 66.

## 9.5 Operation on foreign converters

Principally, operating MKE motors on foreign converters is possible, but the following requirements and limitations on foreign converters must be observed.

### ▲ WARNING

#### Danger of explosion or material damage due to overload!

Observe the following requirements for safe motor operation on foreign converters. Connection of all necessary sensors and additional devices for a safe operation and their evaluation lies in the sole responsibility of the plant manufacturer or operator.

Requirements on the power output stage

- Converter with pulse width modulation
- Pulse frequency 4 kHz ... 16 kHz

#### Voltage load of the motor

During converter operation, the motor underlies a higher voltage load (insulation system, bearing) than on a sinusoidal source voltage only.

Standard values for peak voltage and rate of rise of voltage:

- Peak voltage  $U_{pk}$  on motor clamps  $\leq 1.56\text{ kV}$
- Rate of rise of voltage  $du/dt \leq 5\text{ kV}/\mu\text{s}$

#### Maximum allowed limit load:



In the case of critical rate of rise of off-state voltage  $du/dt \geq 5 \text{ kV}/\mu\text{s}$ , the limit values (peak voltage, voltage rise time) according to limit curves A according to **DIN VDE 0530-25 (VDE 0530-25):2009-08 (Figure 14 Limit curve A)** must be kept. Therefore, observe the limit values for voltage rise time and critical rate of rise of off-state voltage.

#### Limit values for voltage rise time and critical rate of rise of off-state voltage:

- Voltage rise time  $> 0.17 \mu\text{s}$
- Rate of rise of off-state voltage  $du/dt < 8 \text{ kV}/\mu\text{s}$

#### Monitoring functions

- Speed monitoring of maximum permissible speed
- The motor load must not exceed the allowed continuous operation characteristic curve. The converter setting data for controlling and monitoring must comply with the type code data.
- Connect and evaluate the temperature sensor of the motor winding (ensure monitoring function, limit switch-off temperature).

Depending on the converter used, function-tested triggering devices with the  II 2 G or  II 2 D designation may be required to evaluate the temperature sensors. For supplementary information on temperature monitoring, refer to EN60079-14:2014. Compare overview about arrangement for a direct and safe temperature evaluation and monitoring → Chapter 6.2.3 “Thermal motor protection” on page 34.

#### Safe disconnection of the load circuit must be ensured.

- Temperature model or  $I^2t$ -monitoring within converter. Due to the coupling time of the temperature sensor, an additional suitable temperature model or an  $I^2t$ -monitoring must be used.

#### Switch-off

- Please observe the notes in section → Chapter 4.6.5 “Switch-off” on page 27.

Requirements for motor operation with holding brake

- Ensure the brake functionality during normal operation due to voltage control, current monitoring, cyclic control of the brake holding torque, for example.
- Provide an external or an integrated protective circuit within the foreign converter to switch the holding brake (inductive load).
- Never use the holding brake of the motor as an operating brake.
- Idle time after an emergency stop before restarting  $\geq 3$  minutes.
- **Do not** do the grinding procedure in hazardous ambience.

#### General notes

- The motors must be grounded via a motor cable and via a second separate ground conductor with minimum **4 mm<sup>2</sup>** cross section. Check that the position of the grounded conductor is fixed before commissioning.
- Use cables with a thermal stability of at least 80°C (176°F).
- **Plug connector:** Never connect or disconnect plug connectors under load!
- Operate MKE motors only with origin connection accessories.
- Observe the limit values for bearing load. If necessary, change the bearing according to → Chapter 6.2.10 “Bearing” on page 41.

After maintenance and repair work, Bosch Rexroth always recommends to do a safety and functionality test on basis of the risk analysis provided by the customer (e.g. for thermal protection, holding brake).

# 10 Maintenance

## 10.1 Cleaning and servicing

### ▲ WARNING

**Operations in the vicinity of live parts are extremely dangerous.**

- Work required on the electric system may only be carried out by skilled electricians. Tools for electricians (VDE tools) are absolutely necessary.
  - Isolate (even auxiliary circuits).
  - Secure against reactivation.
  - Ensure de-energization.
  - Ground and short-circuit.
  - Cover or shield any adjacent live parts.

### ▲ WARNING

**Personal and material damage during maintenance work in operation!**

- Never carry out maintenance work on running machines. While carrying out maintenance work, secure the machine such that it cannot restart or be used by unauthorized persons.

### ▲ CAUTION

**Hot surfaces with temperatures over 60 °C may cause burns!**

- Allow the motors to cool down prior to commencing work. Wear safety gloves. Do not work on hot surfaces.

### Motors

Dirt, dust or chips may adversely affect the functionality of the motors and, in extreme cases, even cause a failure of the motors. Therefore, at regular intervals (after one year at the latest), you should clean the surface of the motors in order to achieve a sufficiently large heat radiation surface.

If the cooling fins are partially covered with dirt, sufficient heat dissipation via the ambient air is no longer possible.

Insufficient heat dissipation can have undesirable consequences. The bearing life is reduced by operation at inadmissibly high temperatures (bearing grease decomposes). Overtemperature switch-off despite operation on the basis of selected data, because the appropriate cooling is missing.



Clean the motor with a moist cloth to avoid electrostatic charge only. Rubbing with non-conductive materials must be avoided to prevent electrostatic charges resulting in ignition hazards.

### Connection cables

#### ▲ WARNING

**Electric shock due to contact with live parts!**

- Change damaged connection cables and decommission the plant immediately. Do not repair any connection lines provisionally.
  - Check the connection cable for damage at regular intervals and replace it if necessary.
  - Check optionally existing drag chains on defects.
  - Check the protective conductor connection at regular intervals for proper condition and tight fit and replace if necessary.

## 10.2 Service repair, maintenance and spare parts

Wearing parts are reliably and professionally repaired and replaced by the Rexroth Service in shopfloor-oriented quality.

MKE may only be repaired at certified Bosch Rexroth service branches.

The service lives of motor components, such as seals and bearings, may vary depending on the operating conditions, such as operation mode,

speed, vibration and shock load, and frequent reverse mode. We recommend to change the bearing after 30,000 operating hours. Shorter replacement intervals may be necessary; cf. checks during operation . We recommend regular visual inspections on shaft sealing rings. Depending on operating conditions, signs of wear may appear after 5,000 operating hours. If necessary, replace the shaft sealing rings.

The Bosch Rexroth service helpdesk at our headquarters in Lohr, Germany and our worldwide service provide You can contact us **24/7**.

Telephone: **+49 (0) 9352 40 50 60**

Fax: **+49 (0) 9352 18 49 41**

Email: [service.svc@boschrexroth.de](mailto:service.svc@boschrexroth.de)

Internet: <https://www.boschrexroth.com>

## Preparing information

For quick and efficient help, please have the following information ready:

- Detailed description of the fault and the circumstances
- Information on the rating plate of the products in question, particularly type codes and serial numbers
- Your contact data (phone number, fax number, email address)

# 11 Disassembly and exchange

## 11.1 Tools required

### NOTICE

#### Motor damage due to strikes onto the motor shaft

- Do not strike the shaft end and do not exceed the allowed axial and radial forces of the motor.



Use suitable tools when disassembling transmission elements.

### Pulling off

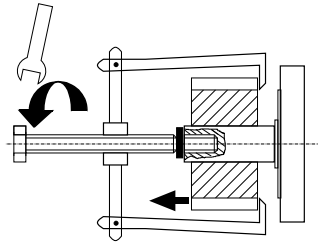

Fig. 27: Remove transmission element

Use tools suitable for pulling off. Use a shim to protect the shaft end when using pulling-off tools. Heat the output element, if necessary.

## 11.2 Replace the motor

### ▲ WARNING

**Electric shock due to live parts with more than 50 V!**

Replacement may only be performed by personnel trained and qualified to work on or with electrical equipment.

**Remark:** The motor must be replaced by a motor of identical type. This is the only way to ensure that all adjusted parameters can remain unchanged.

1. ➤ If necessary, note the previous absolute value
2. ➤ Open the main switch
3. ➤ Make sure the main switch cannot be switched back on
4. ➤ Disconnect electrical connections

**Remark:** Protect electrical connections from pollution (allowed pollution severity "2" according to EN 50178:1997).

5. ➤ Replace the motor
  - ⓘ **Remark:** Observe the machine manufacturer's instructions when exchanging the motor mechanically.
6. ➤ Rebuilt electrical connections
7. ➤ Re-establish the dimensional reference

**▲ WARNING**

**Risk of accidents due to unintentional axis movements!** If servo axes are provided with an indirect position measuring system via the motor encoder, the dimensional reference is lost after motor replacement!

Restore dimensional reference to the machine coordinate system after replacing the motor.

## 11.3 Preparing storage

Before storing motors, the protective covers attached to the motor at the time of delivery must be fitted.

## 12 Environmental protection and disposal

Disposal of the motor components can be done according to the applicable legal process in normal recycling process.

### Recycling

Most of the products can be recycled due to their high content of metal. In order to recycle the metal in the best possible way, the products must be disassembled into individual assemblies. Metals contained in electric and electronic assemblies can also be recycled by means of special separation processes.

### Basic components

Basically, our motors consist of the following components:

- Steel, stainless steel, aluminum, copper, brass
- Plastic parts, insulation and composite material
- Electronic components
- Permanent magnets

Plastic parts of the products may contain flame retardants. These plastic parts are labeled according to EN ISO 1043-1:2011 + A1:2016. They have to be recycled separately or disposed of according to the applicable legal provisions.

### Magnets

**▲ WARNING**

#### Danger due to permanent magnets!

- Health hazard for persons with heart pacemakers, metallic implants and hearing aids in direct environment of permanent magnets.
- Crushing hazard of fingers and hand due to heavy attractive forces of the magnets.
- Risk of destruction of sensitive parts like watches, credit cards, ...

ⓘ **Remark:** The permanent magnets must be demagnetized before disposal to avoid injuries or damage. The demagnetization is reached via thermal treatment. The duration of the treatment depends on the size (guide value: 300 °C, 30 min).

### Packaging

Our packaging materials do not contain any problematic materials and can therefore be easily disposed. Packaging materials are: wood, cardboard and polystyrene.

## Batteries and accumulators



The symbol indicating "separate collection" for all batteries and accumulators is the crossed-out wheeled bin. End users in the EU are legally bound to return used batteries and accumulators. Outside the scope of the EU Directive 2006/66/EC, the applicable regulations must be followed. Batteries and accumulators can contain hazardous substances which can harm the environment or people's health when improperly stored or disposed of. The batteries or accumulators must be returned to the country-specific collection systems for proper disposal.

### Disposal by the manufacturer

Our products can be returned to us for disposal. However, this requires that the products are free from oil, grease or other dirt. The motor components must be returned in a suitable packaging (origin package if possible). In the case of a transport by air freight, please observe the dangerous goods regulations (IATA) for the secondary part.

Send the products to the following address, carriage free:

Bosch Rexroth AG  
Bgm.-Dr.-Nebel-Str. 2  
97816 Lohr a.Main, Germany

## 13 Eliminate malfunction

As a matter of principle, the instructions in the project planning and commissioning manuals must be followed in case of failures and errors. Contact the manufacturer, if necessary.

Fault description	Cause	Remedy
Motor does not run	Controller enable signal missing	Activate controller enable signal
	Controller fault	Troubleshoot acc. to documentation of controller
	Voltage supply missing	Control voltage supply
	Brake is not released	Check the brake activation

Fault description	Cause	Remedy
Vibrations	Coupling elements or attachments are poorly balanced	Re-balance
	Adjustment of shaft end attachments (coupling, gearbox, ...) is insufficient	Re-align the attachments
	Mounting screws loose	Lock screw connections acc. to specifications

Fault description	Cause	Remedy
Running noise	Foreign bodies within the motor	Stop the motor; repair by manufacturer
	Bearing is damaged	Stop the motor; repair by manufacturer

Fault description	Cause	Remedy
High motor temperatures; motor temperature monitoring is activated	Operation outside the parameters	Reduce load and check the dimensioning
	Heat dissipation is impaired	Clean the motor

As a matter of principle, the instructions in the project planning and commissioning manuals must be followed in case of failures and errors. Contact the manufacturer, if necessary.

## 14 Technical data

### 14.1 Technical data type plate

Type	Continuous torque at standstill 60K $M_{0,60}$ Nm	Continuous current at standstill 60K $I_{0,60(eff)}$ A	Maximum speed (electrical) $n_{max}$ min <sup>-1</sup>	Voltage constant at 20 °C 1) KEMK_1000 V/1000 min <sup>-1</sup>	Torque constant at 20 °C Km Nm/A	Mass $m_{mot}$ kg
MKE037B-144-__0-E__	0.9	3.3	9,000	18.2	0.30	2.5
MKE037B-144-__1-E__	0.8	3.0	9,000	18.2	0.30	2.8
MKE047B-144-__0-E__	2.7	5.0	7,000	36.3	0.59	5.5
MKE047B-144-__1-E__	2.7	5.0	7,000	36.3	0.59	5.8

Type	Continuous torque at standstill 60K $M_{0,60}$ Nm	Continuous current at standstill 60K $I_{0,60(eff)}$ A	Maximum speed (electrical) $n_{max}$ min <sup>-1</sup>	Voltage constant at 20 °C KEMK_1000 V/1000 min <sup>-1</sup>	Torque constant at 20 °C Km Nm/A	Mass $m_{mot}$ kg
MKE098B-047-__0_-E_	12.0	9.8	4,500	91.0	1.41	18.0
MKE098B-047-__1_-E_	12.0	9.8	4,500	91.0	1.41	19.1
MKE098B-058-__0_-E_	12.0	12.4	5,000	70.0	1.09	18.0
MKE098B-058-__1_-E_	12.0	12.3	5,000	70.0	1.09	19.1
MKE118B-024-__0_-E_	28.0	15.3	4,000	130.0	2.12	45.0
MKE118B-058-__0_-E_	28.0	28.4	4,500	70.0	1.15	45.0
MKE118B-058-__1_-E_	28.0	28.4	4,500	70.0	1.15	46.0
MKE118D-012-__0_-E_	48.0	13.0	2,100	263.5	4.29	65.0
MKE118D-027-__0_-E_	48.0	22.1	3,000	154.5	2.52	65.0
MKE118D-035-__0_-E_	48.0	29.8	3,000	114.5	1.87	65.0

1) Manufacturing tolerance  $\pm 5\%$

## 14.2 Axial force

Motor	Symbol	Unit	Value
MKE037	$F_A$	Nm	Not permitted
MKE047	$F_A$	Nm	30
MKE098	$F_A$	Nm	60
MKE118	$F_A$	Nm	200

## 14.3 Radial force

### 14.3.1 MKE037 Radial force

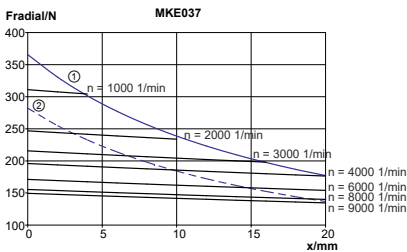

Fig. 28: MKE037: permissible radial force

- ① Shaft plain
- ② Shaft with keyway

### 14.3.2 MKE047 Radial force

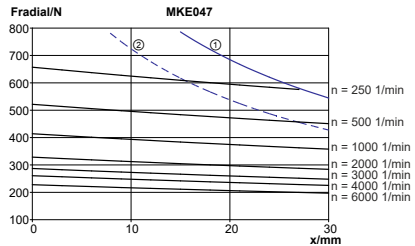

Fig. 29: MKE047: permissible radial force

- ① Shaft plain
- ② Shaft with keyway

### 14.3.3 MKE098 Radial force

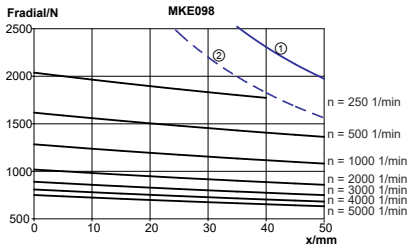

Fig. 30: MKE098: permissible radial force

- ① Shaft plain
- ② Shaft with keyway

### 14.3.4 MKE118 Radial force

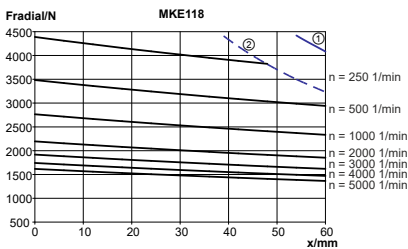
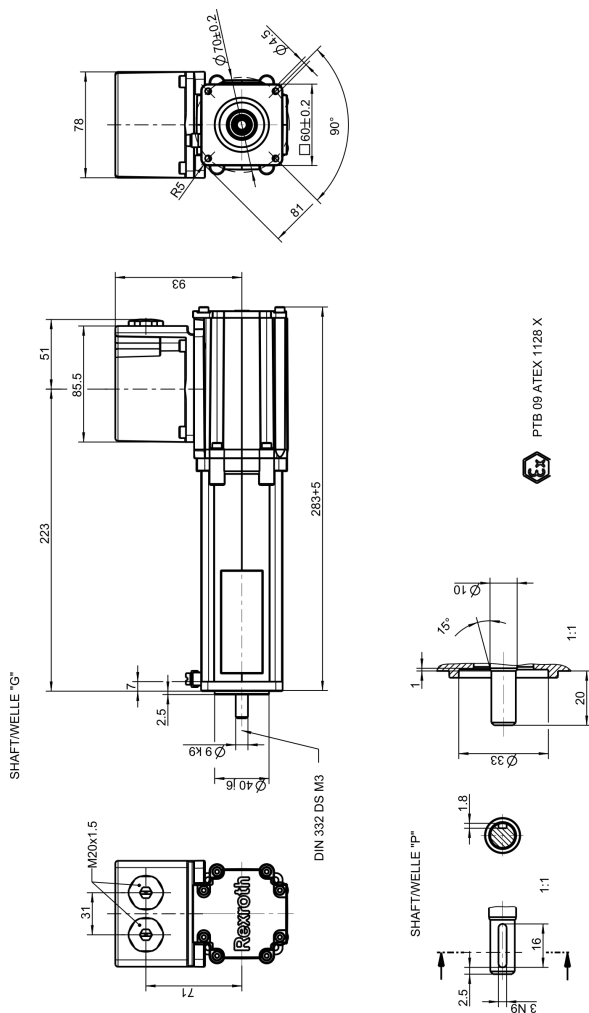

Fig. 31: MKE118: permissible radial force

- ① Shaft plain
- ② Shaft with keyway

## 14.4 Specifications

### 14.4.1 MKE037 Specifications



R076519831 MKE037B-XXX-XXX-XXX-BE0N\_AA

Fig. 32: Specifications MKE037B

### 14.4.2 MKE047 Specifications

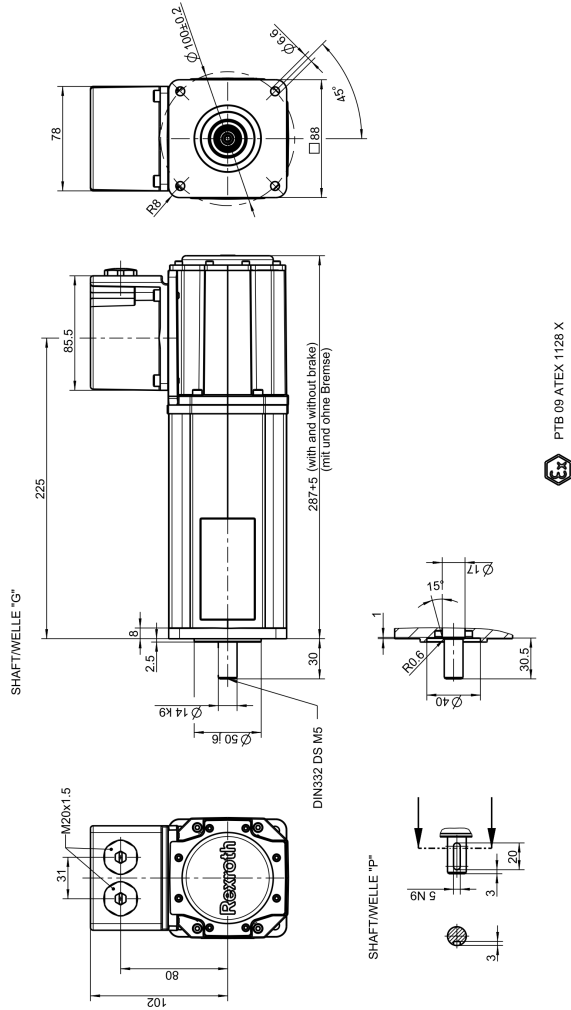

RA62571237\_MKED47

Fig. 33: Specifications MKE047

### 14.4.3 MKE098 Specifications

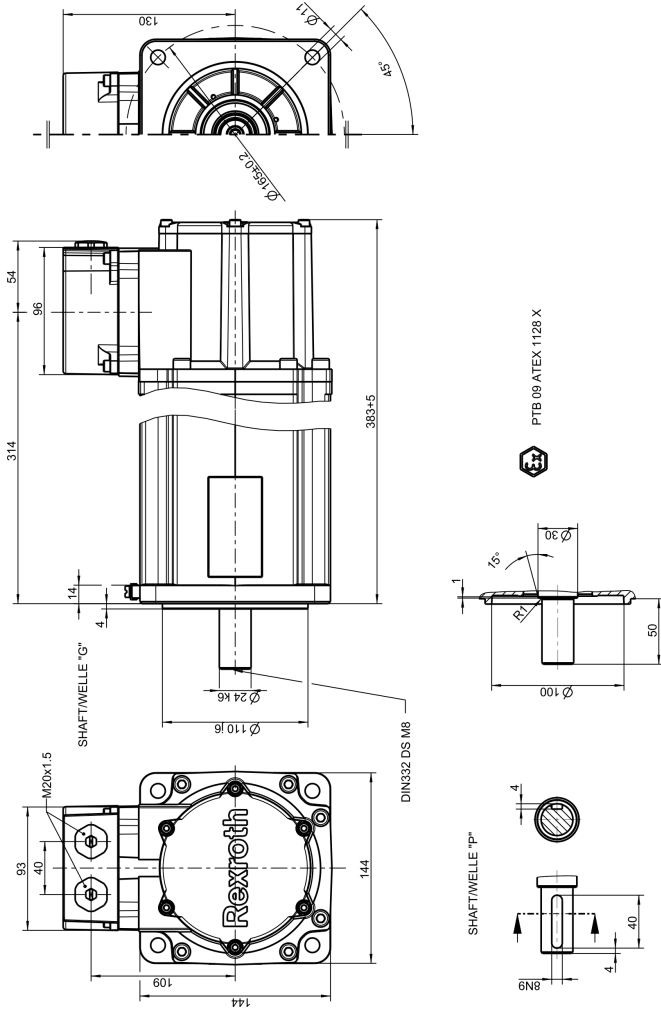

Fig. 34: Specifications MKE098B



# 15 Appendix

## 15.1 EU Declaration of conformity



### EU-Konformitätserklärung - Original EU declaration of conformity

Dok.-Nr. / Doc. No.: DCTC-30504-003

Datum / Date: 2021-06-01

- nach Maschinenrichtlinie 2006/42/EG / in accordance with Machinery Directive 2006/42/EC
- nach Niederspannungsrichtlinie 2014/35/EU / in accordance with Low Voltage Directive 2014/35/EU
- nach EMV-Richtlinie 2014/53/EU / in accordance with EMC Directive 2014/53/EU
- nach Druckgeräte-Richtlinie 2014/68/EU / in accordance with Pressure Equipment Directive 2014/68/EU
- nach ATEX-Richtlinie 2014/34/EU / in accordance with ATEX Directive 2014/34/EU
- nach RoHS-Richtlinie 2011/65/EU / in accordance with RoHS Directive 2011/65/EU

Hiermit erklärt der Hersteller, / The manufacturer

Bosch Rexroth AG, Bgm.-Dr.-Nebel-Str. 2, 97816 Lohr a.Main / Germany

dass die nachstehenden Produkte / hereby declares that the products below

Bezeichnung / Name: 3- PM-MOTOR

Motortypen / Motor types:	MKE037-...-A...-E0	MKE037-...-C...-E0	MKE047-...-A...-E0
	MKE047-...-C...-E0	MKE098-...-A...-E0	MKE098-...-B...-E0
	MKE098-...-C...-E0	MKE098-...-D...-E0	MKE118-...-A...-E0
	MKE118-...-B...-E0	MKE118-...-C...-E0	MKE118-...-D...-E0

Handelsbezeichnung / Trade name: Rexroth  
ab Herstellungsdatum / from the date of manufacture: 2021-06-01

in Übereinstimmung mit oben genannte(n) Richtlinie(n) entwickelt, konstruiert und gefertigt wurden. / were developed, designed and manufactured in compliance with the above-mentioned directive(s).

Die alleinige Verantwortung für die Ausstellung dieser EU-Konformitätserklärung trägt der Hersteller. / This EU declaration of conformity is issued under the sole responsibility of the manufacturer.

© Bosch Rexroth AG 2021  
DCTC-30504-003\_KOE\_N\_DO\_2021-06-01.docx

Angewandte harmonisierte Normen / Harmonized Standards applied:

Norm / Standard	Titel / Name	Ausgabe / Issue
EN IEC 60079-0 (IEC 60079-0)	Explosionsgefährdete Bereiche – Teil 0: Geräte – Allgemeine Anforderungen / Explosive atmospheres – Part 0: Equipment – General requirements	2018/AC:2020 (2017/COR1:2020)
EN 60079-1 (IEC 60079-1)	Explosionsgefährdete Bereiche – Teil 1: Geräteschutz durch druckfeste Kapselung „d“ Explosive atmospheres – Part 1: Equipment protection by flameproof enclosures „d“	2014/AC:2018-08 (2014/COR1:2018)
EN 60079-31 (IEC 60079-31)	Explosionsgefährdete Bereiche – Teil 31: Geräte-Staubexplosionsschutz durch Gehäuse „d“ / Explosive atmospheres – Part 31: Equipment dust ignition protection by enclosure “d”	2014 (2013)

Seite Page 1 / 2

## UK Declaration of Conformity (UK Declaration of Conformity)

EU-Konformitätserklärung - Original  
EU declaration of conformity

Seite Page 2 / 2  
DCTC-30504-003 : 2021-06-01

Die Motoren haben folgende Kennzeichnungen / the motors have the following markings:

Ⓜ II 2G Ex db IIB T4 Gb  
Ⓜ II 2D Ex tb IIIC T135°C Db

Benannte Stelle, die das EU-Baumusterprüfverfahren nach oben genannter Richtlinie durchgeführt hat /  
Notified body that has conducted the EU type-examination procedure in accordance with the above-mentioned directive:

Name / Name:	Physikalisch-Technische Bundesanstalt (PTB)
Anschrift / Address:	Bundesallee 100, 38116 Braunschweig / Germany
Kennnummer / Identification number:	0102
EU-Baumusterprüfbescheinigungs-Nr. /	PTB 09 ATEX 1127 X (MKE118)
No. of EU type-examination certificate:	PTB 09 ATEX 1128 X (MKE037, MKE047, MKE098)

Benannte Stelle, die das umfassende Qualitätssicherungssystem nach oben genannter ATEX-Richtlinie genehmigt hat /  
Notified body that has approved the comprehensive quality assurance system according to the above-mentioned ATEX directive:

Name / Name:	DEKRA Testing and Certification GmbH
Anschrift / Address:	Dinnendahlstr. 9, 44809 Bochum
Kennnummer / Identification number:	0158

Weitere Erläuterungen / Further explanations:

Das Produkt ist ausschließlich zum Einbau in eine Maschine bestimmt. Der bestimmungsgemäße Gebrauch des Produktes setzt die Einhaltung der Benutzungsbestimmungen und Anwendungsbedingungen, die in der Betriebsanleitung angegeben werden, durch den Nutzer voraus. /

The product is intended solely for installation in a machine. For the product to be used as intended the user must comply with the provisions of use and conditions of application laid down in the instructions.

_____ Ort / Place	_____ 2021-06-01 Datum / Date	_____ ppa. Uwe Gzychy Werkleitung LoP2 / Plant Manager LoP2	_____ i.V. Dr. Hans-Jürgen Wehner Leitung Entwicklung Motoren / Head of Development Motors
----------------------	-------------------------------------	---	--

Anderungen im Inhalt der EU-Konformitätserklärung sind vorbehalten. Derzeit gültige Ausgabe auf Anfrage.  
We reserve the right to make changes to the content of the EU Declaration of Conformity. Current issue on request.

## 15.2 UK Declaration of Conformity (UK Declaration of Conformity)

**UK  
CA**

The products fulfill the requirements of "Product or Protective System Intended for use in Potentially Explosive Atmospheres UKSI 2016:1107 (as amended by UKSI 2019:696) – Schedule 3A, Part 1".

The UK Declaration of Conformity can be found in the Bosch Rexroth Media Directory: → [www.boschrexroth.com/mediadirectory](http://www.boschrexroth.com/mediadirectory), Suchwort: → „DCTC-30455-033“.

### 15.3 UL / CSA



The UL/CSA conformity of MKE motors can be found on the type plate of the motors.

MKE motors according to **ATEX** and **UKEx** standards are “UL Recognized”. Information can be found under UL file number E335445 on the website → [www.ul.com](http://www.ul.com).

### 15.4 China RoHS 2



The China RoHS 2 conformity can be found on the type plate of the motors.

Information about listing:  
→ <https://www.boschrexroth.com.cn/zh/cn/certificates/china-rohs2/>

# Index

## A

Accumulators.....	65
Ambient conditions.....	59
Ambient temperature.....	59
Attachments.....	37

## B

Balancing.....	36, 37
Batteries.....	65
Bearing.....	41
Axial force.....	42
Bearing service life.....	41
Radial force.....	42
Bevel gear pinion.....	38

## C

Coating.....	43
Connection conditions.....	27
Couplings.....	37
CSA.....	75

## D

Declaration of Conformity	
UK Declaration of Conformity.....	74
Degree of protection.....	36
Disposal.....	64

## E

Emergency stop.....	27, 28
Encoder.....	36
Extension elements.....	36

## F

Frame size.....	42
-----------------	----

## G

Grounding.....	27
----------------	----

## H

Helical teeth.....	38
Holding brake	
Commissioning.....	41
Housing temperature (maximum).....	27

## I

IC410.....	35
IM-Code EN 60034-7.....	42

Installation type.....	42
IP code EN 60529:1991 + A1:2000 + A2:2013	
.....	36

## M

Maintenance.....	62
Materials contained.....	64
Motor temperature.....	34

## O

Operation on foreign converters.....	60
Output shaft.....	36
Overdetermined bearing.....	37

## P

Packaging.....	64
----------------	----

## R

Replace the motor.....	63
Residual risks.....	28
Returning products.....	65
Risk of corrosion.....	27
RoHS	
China RoHS 2.....	75

## S

Self-cooling	
IC410.....	35
Shaft	
smooth.....	36
with keyway.....	37
Shutdown temperature.....	35
Sound pressure level.....	43
Storage.....	43
Switch-off.....	27

## T

Technical data.....	66
Thermo controller.....	47
Transmission element.....	45
Fitting.....	45
Pulling off.....	63
Transport.....	43
Troubleshooting.....	66

## U

UK Declaration of Conformity.....	74
UL.....	75

**V**

Vibration behavior..... 41

**W**

Warning temperature..... 35





Bosch Rexroth AG  
Bgm.-Dr.-Nebel-Str. 2  
97816 Lohr a.Main  
Germany  
Tel. +49 9352 18 0  
Fax +49 9352 18 8400  
[www.boschrexroth.com/electrics](http://www.boschrexroth.com/electrics)



R911402016