

AuburnGear
Engineered Drive Solutions

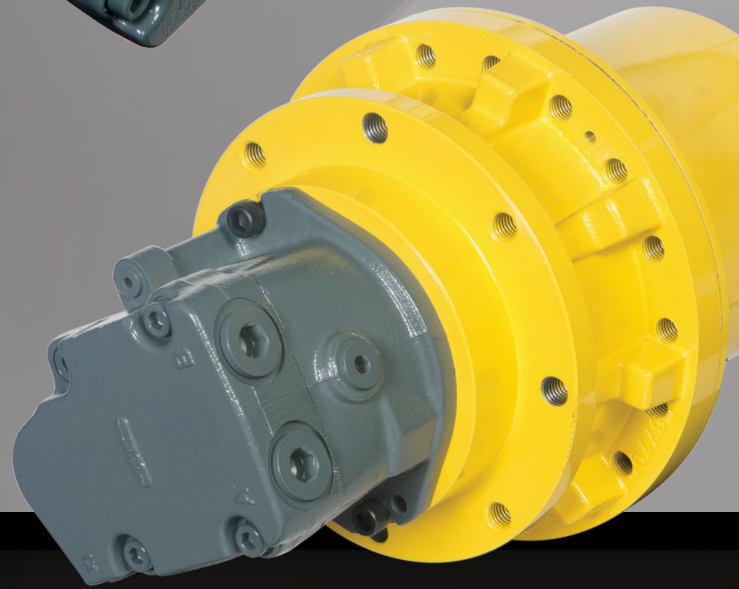
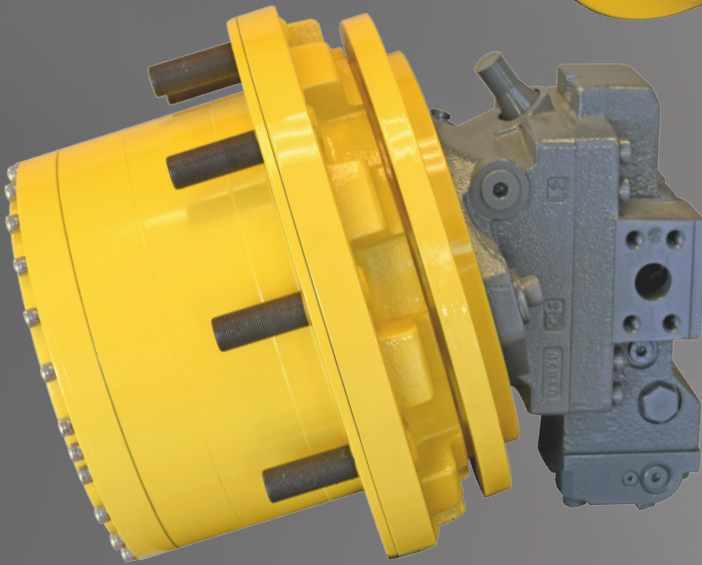
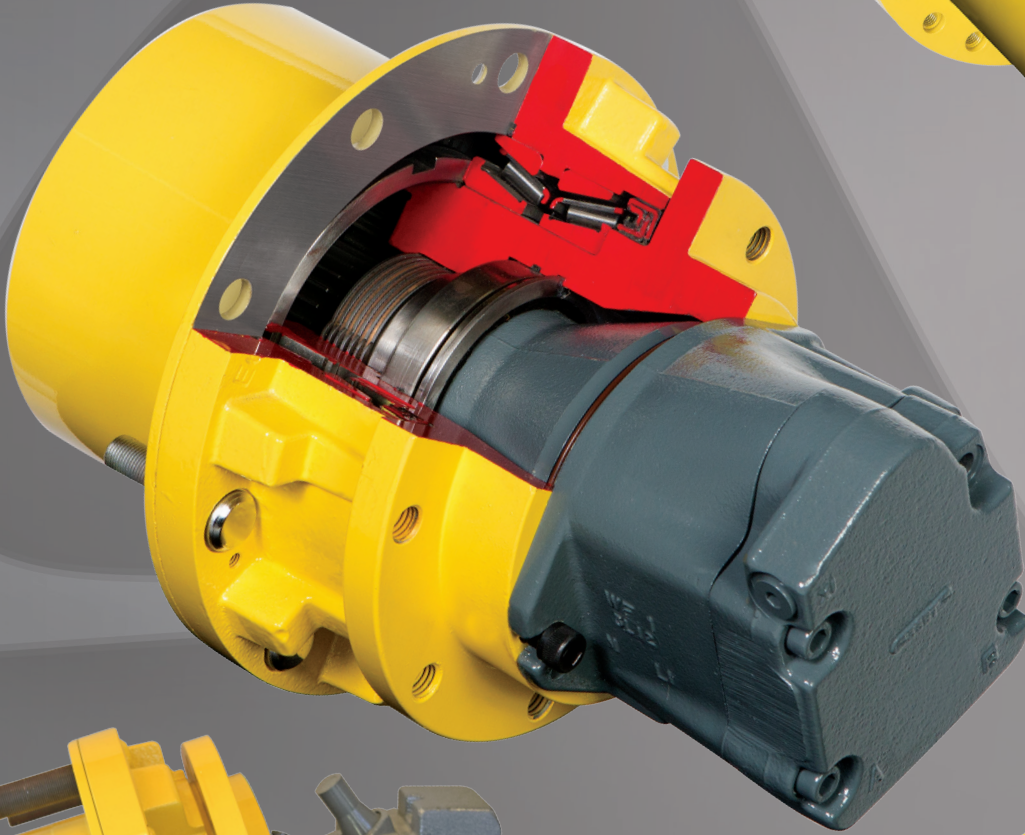
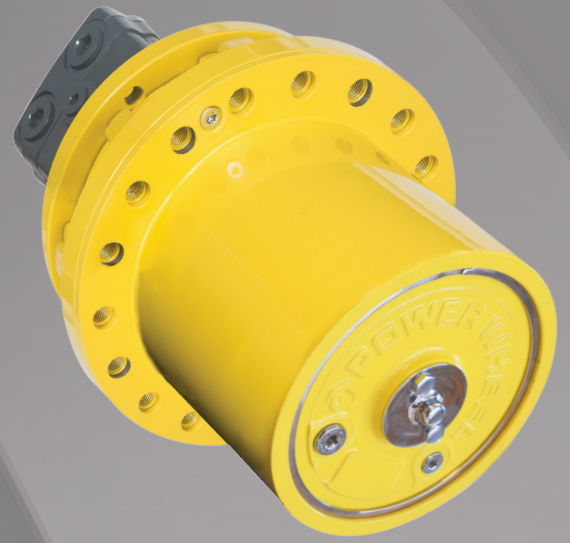

OIL SOLUTIONS

PO Box 38
Strathfieldsaye, VIC, 3551
1800 OIL SOL
1800 645 765

sales@oilsolutions.com.au

www.oilsolutions.com.au

"For All Your Hydraulic Needs"

Power Wheel®

Model 70CD, 110CD, 161CD, and 160CD Drives
Compact Final Drives

260.925.3200 AuburnGear.com



Compact Final Drive
Features.....3

Model 70 CD
Compact Final Drives.....4–5

Model 110 CD
Compact Final Drives.....6–7

Model 161 CD
Compact Final Drives.....8–9

Model 160 CD
Compact Final Drives.....10–11



1800-OILSOL
1800-645765

<https://oilsolutions.com.au/>

sales@oilsolutions.com.au

Compact Final Drive Features

- One by-product of a plug-in style motor design is larger tapered roller bearings
- As part of the motor is buried into the spindle this forces the designer to use a larger bearing set
- Auburn Gear has taken this a step further by spreading these bearings out as well to provide more radial capacity over a larger area

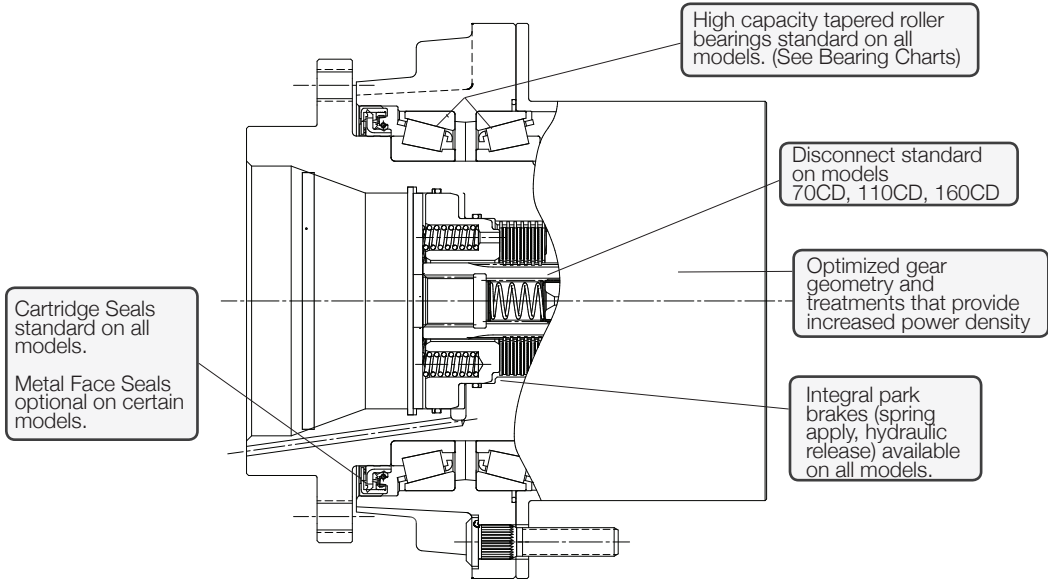

Compact Final Drive Bearing Curves

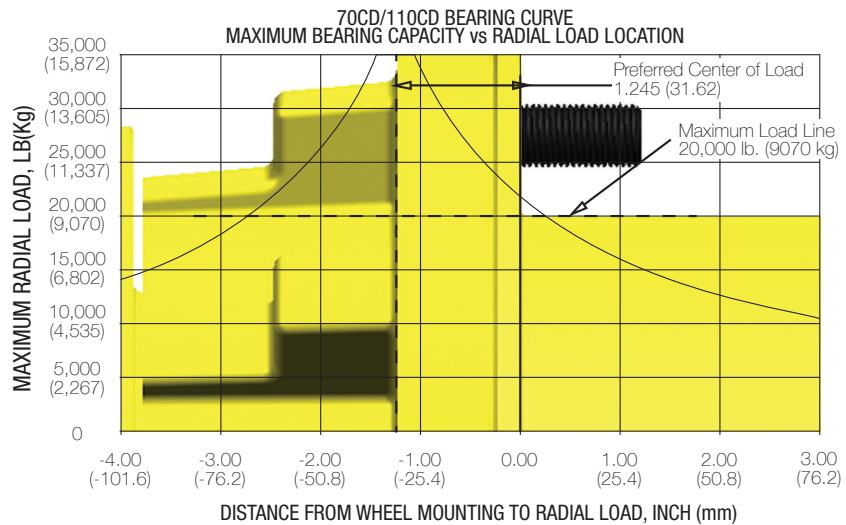
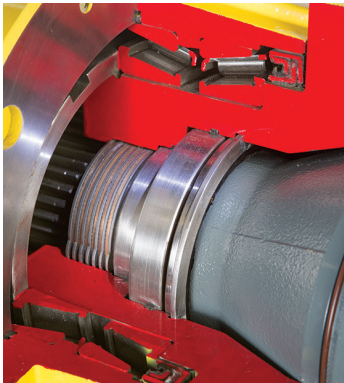

Two Advantages of 161CD/160CD vs Competition:

- 1 – Increased radial load capacity by 27%
- 2 – Increased max load range by 50%, and the max load range is in a load location customer will utilize

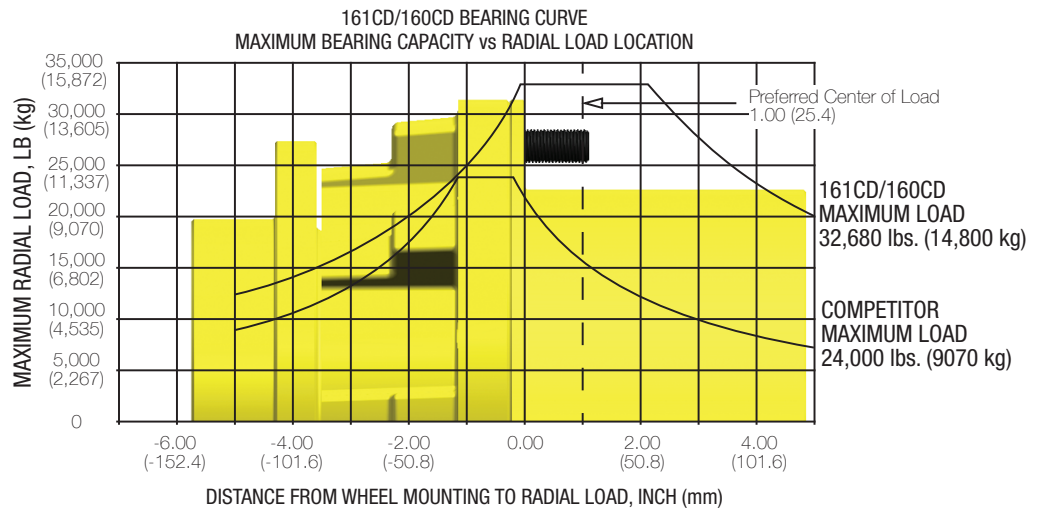

NOTE:

These curves are supplied as a design guide and apply to resultant radial load only. They indicate the importance of maintaining load position over the bearing center. The curves were developed based on a B10 life of 3000 hours at 100 RPM.

For actual analysis, applications should be reviewed by Auburn Gear Engineering using data supplied on Application Data Form.

Power Wheel® Model 70CD Compact Final Drive

General Specifications

Double Reduction

Max. intermittent output torque^{1,2}.....70,000 lb-in (7,910 Nm)
 Max. input speed²5,000 RPM
 Approximate Weight 110 lbs (50 kg)
 Oil capacity 22 oz (650 cc)
 Max. radial load: (@ pref. load center).....20,000 lbs (9100 kg)

Triple Reduction

Max. intermittent output torque^{1,2}.....70,000 lb-in (7,910 Nm)
 Max. input speed²5,000 RPM
 Approximate Weight 125 lbs (57 kg)
 Oil capacity 35 oz (1035 cc)
 Max. radial load: (@ pref. load center).....20,000 lbs (9100 kg)

¹ Depending on the duty cycle and the nature of the application, a normal continuous output torque of 1/3 to 1/2 of the maximum Intermittent should yield satisfactory Power Wheel® life. Customer testing and application analysis is strongly recommended.

² If application exceeds published limit, contact Auburn Gear.

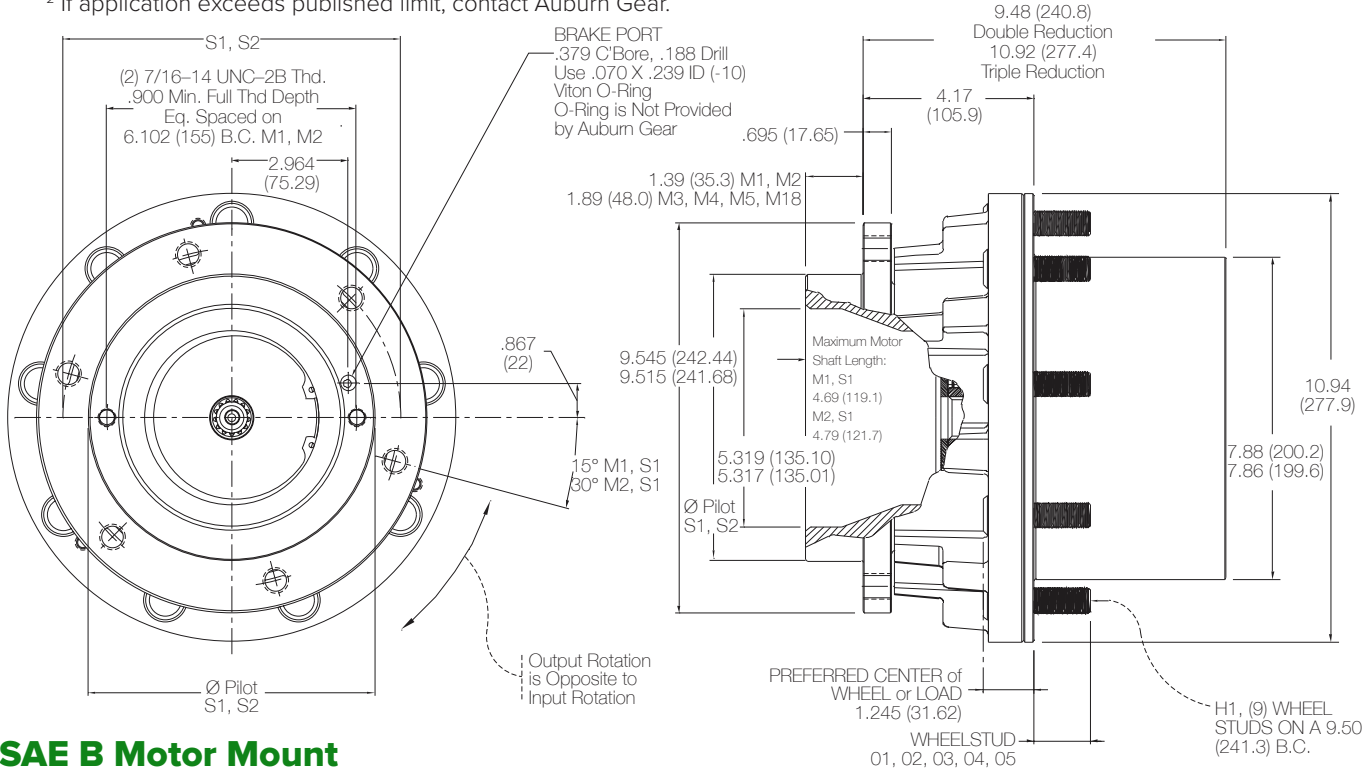

SAE B Motor Mount

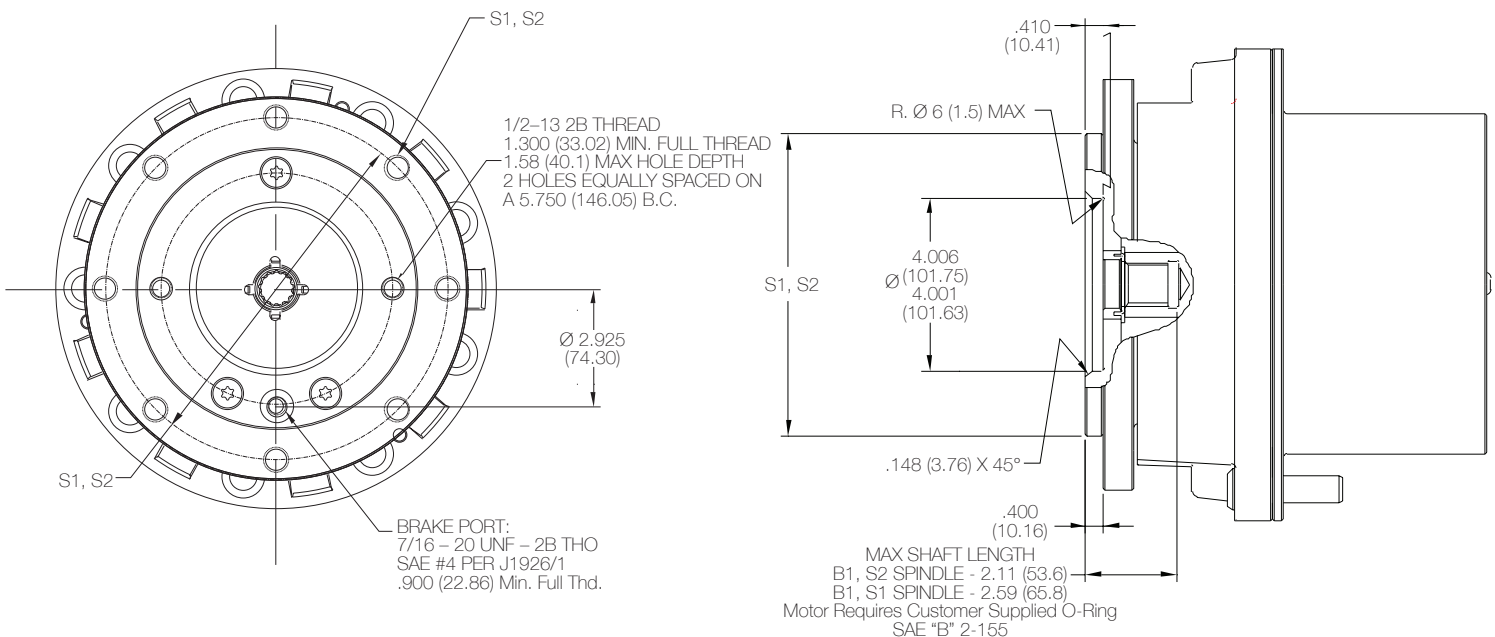

70CD

Model Formula

Ratios	Triple Reductions
014 = 14.30:1	080 = 80.70:1
017 = 17.94:1	087 = 87.89:1
022 = 22.71:1	097 = 97.04:1
025 = 25.15:1	100 = 100.00:1
028 = 28.37:1	109 = 109.03:1
032 = 32.79:1	125 = 125.59:1
037 = 37.52:1	136 = 136.72:1
046 = 46.74:1	150 = 150.90:1
058 = 58.09:1	169 = 169.47:1
066 = 66.98:1	195 = 195.12:1
	220 = 220.57:1
	253 = 253.91:1
	276 = 276.35:1
	304 = 304.90:1
	342 = 342.28:1
	393 = 393.35:1

Wheel Studs (Size x Stud length from hub face)
 00 = None, 0.681/0.678 (17.30/17.22) thru holes
 01 = 1/2-20 UNF-2A x 1.50 (38.1)
 02 = 5/8-18 UNF-2A x 1.38 (35.1)
 03 = 9/16-18 UNF-2A x 1.70 (43.2)
 04 = M16 x 1.5-6g x 50
 05 = M18 x 1.5-6g x 45

Brakes
 N0 = No Brake
 N1 = 1,600 lb-in (180 Nm), 140 psi (9.6 Bar) release
 N2 = 2,400 lb-in (270 Nm), 180 psi (12.4 Bar) release
 N3 = 3,600 lb-in (405 Nm), 200 psi (13.8 Bar) release

Model 70CD
 CW070

Hub Mount
 H1—(9) Wheel Studs on 9.50 (241.3) B.C.
 H2—(12) M14 x 2.0 threaded thru on 10.316 (262.0) B.C.

CW070 M1 H1 S1 014 01 N1 Z

Cartridge Motor Inputs
 M1—Danfoss KC-15T Input M5—Parker F12-30
 M2—Danfoss LC-13T Input M18—Sunfab 025 & 034
 M3—Bosch A6VE (28cc) 14T, 2 Module
 M4—Bosch A2FE (28cc and 32cc)

B1—SAE B Motor Mounting, 13T
 B2—SAE B Motor Mounting, 15T

Spindle Frame Mount
 S1—(6) 5/8-11 UNC-2B on 8.25 (209.6) B.C. Pilot-7.000/6.995 (177.80/177.67)
 S2—(8) 5/8-11 UNC-2B on 8.50 (215.9) B.C. Pilot-6.895/6.865 (175.13/174.37)

Special Options
 0= None
 Z= Boot Seal
 DH= Disc Holes
 D= Assembled Rotor

M18 Motor Mount

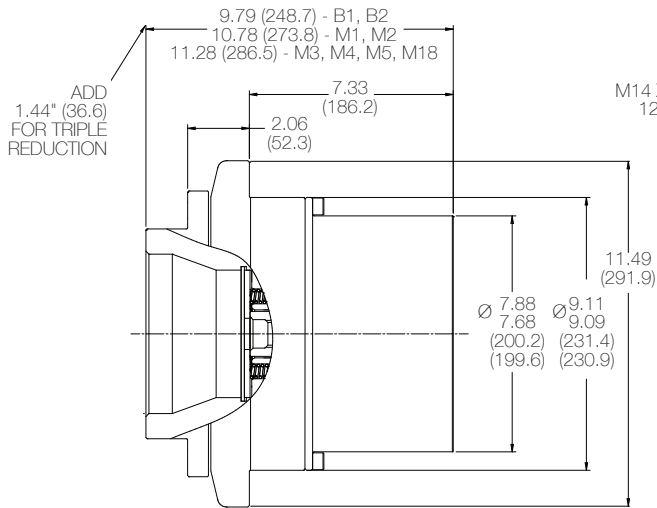
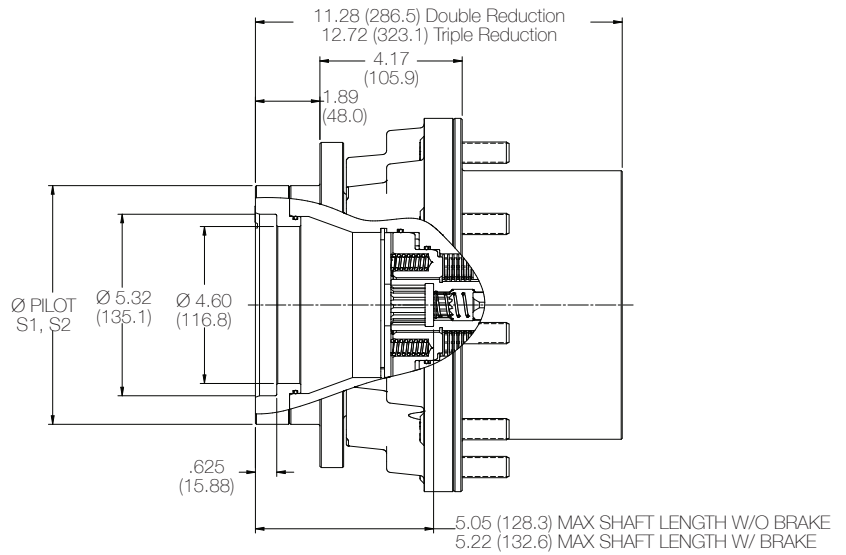
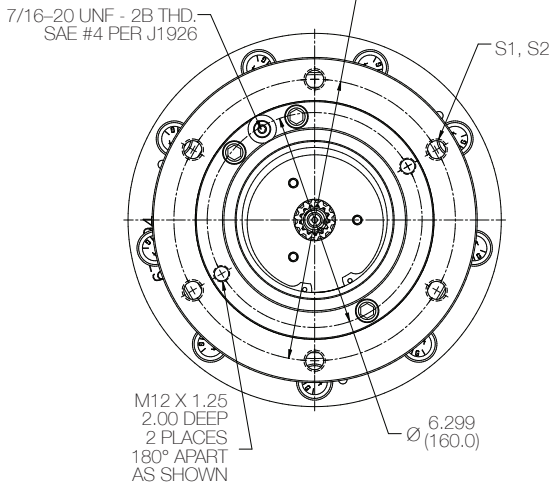

H2 Hub Configuration

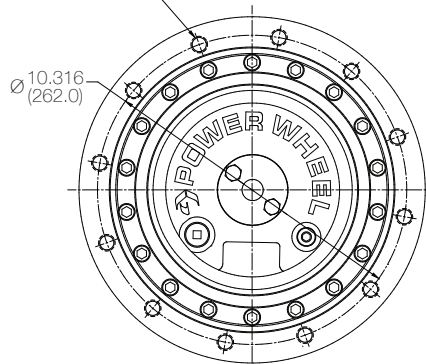

1800-OILSOL
 1800-645765

<https://oilsolutions.com.au/>

sales@oilsolutions.com.au



Power Wheel® Model 110CD Compact Final Drive

General Specifications

Max. intermittent output torque ^{1,2}	110,000 lb-in (12,430 Nm)	Approximate Weight	125 lbs (57 kg)
Max. input speed ²	5,000 RPM	Oil capacity	35 oz (1035 cc)
		Max. radial load:(@ pref. load center).....	20,000 lbs (9100 kg)

¹ Depending on the duty cycle and the nature of the application, a normal continuous output torque of 1/3 to 1/2 of the maximum Intermittent should yield satisfactory Power Wheel® life. Customer testing and application analysis is strongly recommended.

² If application exceeds published limit, contact Auburn Gear.

Small Cavity Motors - M1 thru M5

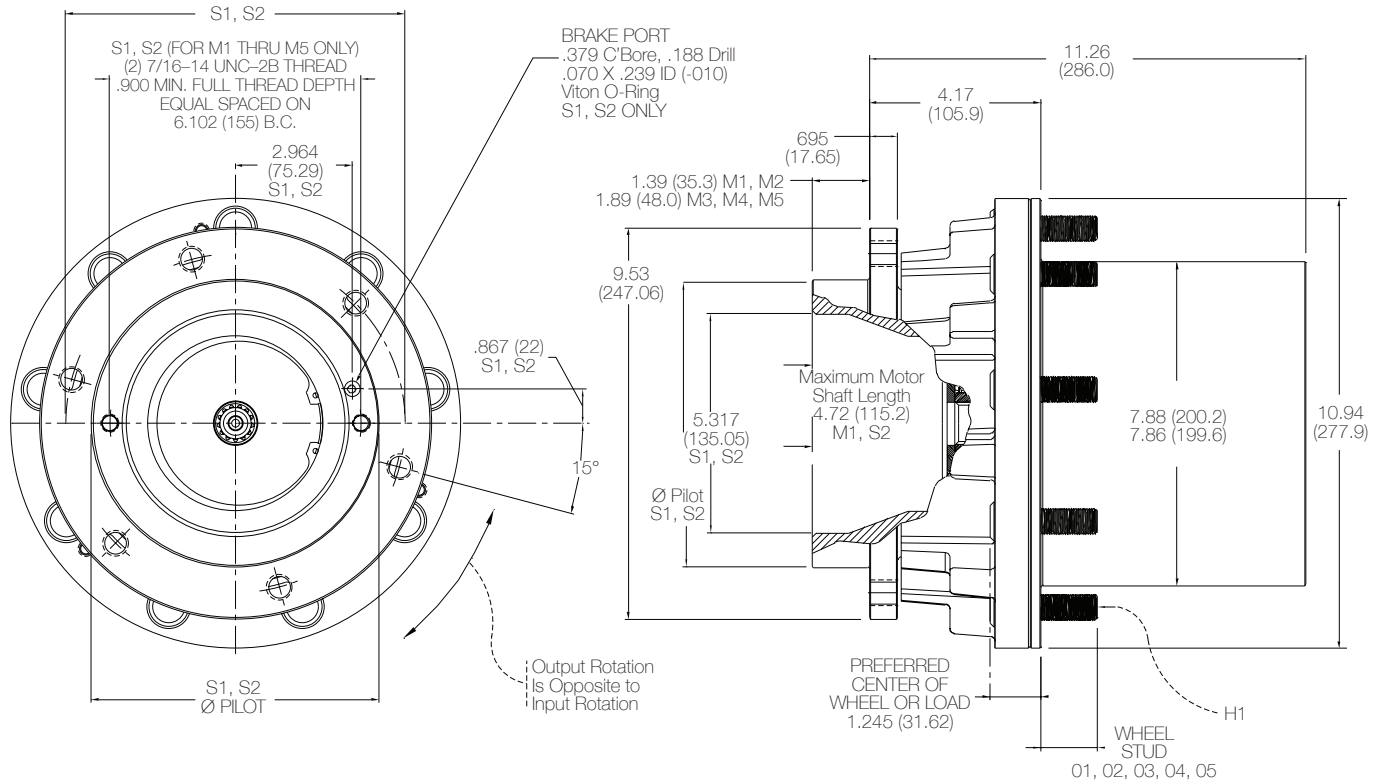

SAE B Motor Mount

1/2-13 UNC 2B THREAD
1.300 (33.02) MIN. FULL THREAD
1.58 (40.1) MAX HOLE DEPTH
2 HOLES EQUALLY SPACED ON
A 5.750 (146.05) B.C.

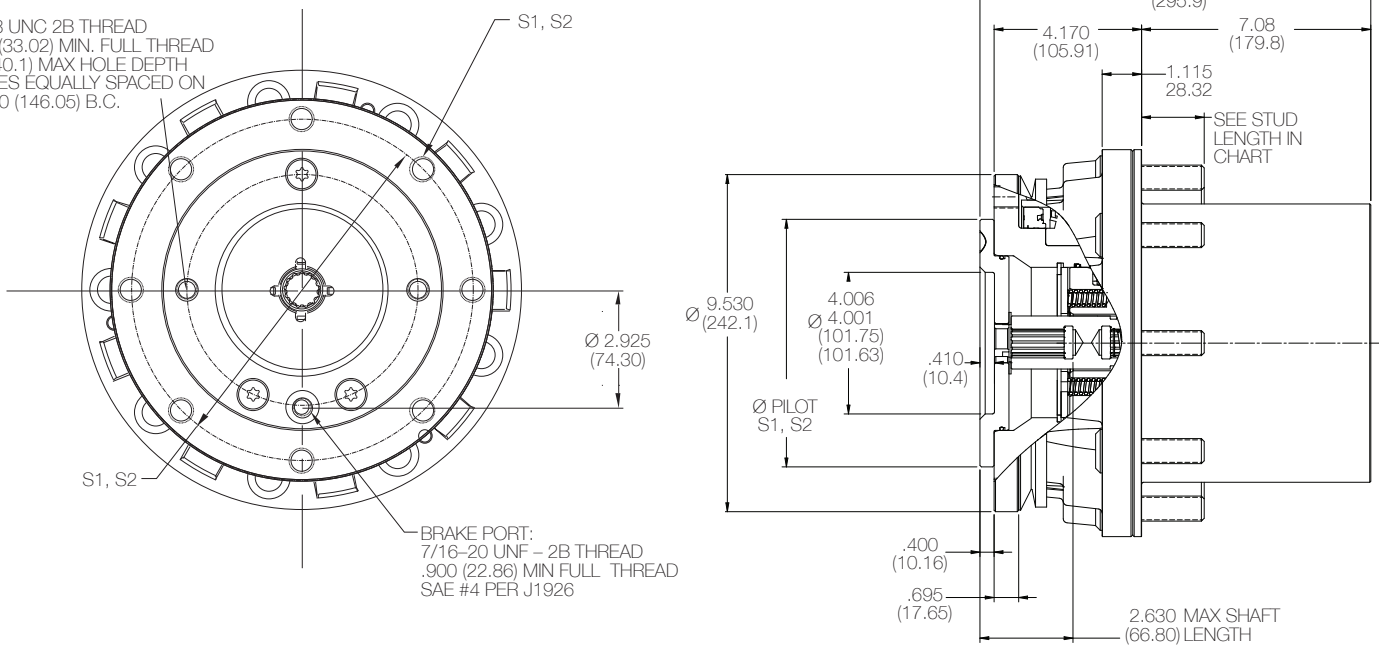

110CD

Model Formula

Model 110CD
CW110

Ratios
014 = 14.30:1 032 = 32.79:1
017 = 17.94:1 037 = 37.52:1
022 = 22.71:1 046 = 46.74:1
025 = 25.15:1 058 = 58.09:1
028 = 28.37:1 066 = 66.98:1

Hub Mount
H1—(9) Wheel Studs on
9.50 (241.3) B.C.
H3—(18) 5/8-11 UNC on
9.50 (241.3) B.C.

Wheel Studs
00 = None, 0.681/0.678 (17.30/17.22) thru holes
01 = 1/2-20 UNF-2A x 1.50 (38.1)
02 = 5/8-18 UNF-2A x 1.38 (35.1)
03 = 9/16-18 UNF-2A x 1.7 (43.2)
04 = M16 x 1.5-6g x 50
05 = M18 x 1.5-6g x 45

Brakes
N0 = No Brake
N1 = 1,600 lb-in (180 Nm), 140 psi (9.6 Bar) release
N2 = 2,400 lb-in (270 Nm), 180 psi (12.4 Bar) release
N3 = 3,600 lb-in (405 Nm), 200 psi (13.8 Bar) release

CW110 M1 H1 S1 014 01 N1 Z

Cartridge Motor Inputs

*M1—Danfoss KC-15T Input	†M8—Danfoss 90K42
*M2—Danfoss LC-13T Input	†M9—Danfoss 90K55
*M3—Bosch A6VE (28cc)	†M10—Bosch A2FE45
*M4—Bosch A2FE (28cc and 32cc)	†M11—Bosch A2FE56
*M5—Parker F12-30	†M12—Bosch A2FE63
†M6—Danfoss 51C060	†M13—Bosch A10VE63 (15T)
†M7—Danfoss H1B060, Rexroth A6VE55	†M14—Parker/VOAC F12-40
	†M15—Parker/VOAC F12-60
	†M16—Parker/VOAC V12-60 (W30)

Special Options
0 = None
D = Assembled Rotor
DH = Disc Holes
Z = Boot Seal
FS = Face Seal *
*Available with Motors M6—M17 only

Spindle Frame Mount
S1—(6) 5/8-11 UNC-2B on 8.25 (209.55) B.C. Pilot-7.000/6.995 (177.78/177.67)
S2—(8) 5/8-11 UNC-2B on 8.50 (215.90) B.C. Pilot-6.895/6.865 (175.13/174.37)
S3—(12) M16 x 2-6H on 10.827 (275.0) B.C. Pilot-9.449/9.444 (240.00/239.88)
S4—(12) 5/8-11 UNC-2B on 8.25 (209.55) B.C. Pilot-7.000/6.995 (177.78/177.67)

*B1—SAE B Motor Mounting, 13T * Use S1 or S2 spindle
*B2—SAE B Motor Mounting, 15T † Use S3 spindle

H3 Hub Configuration

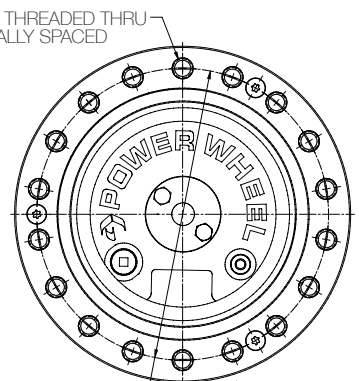
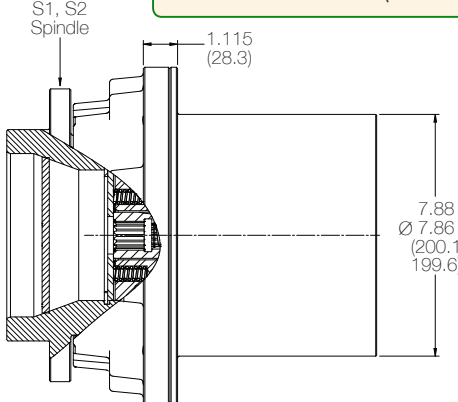
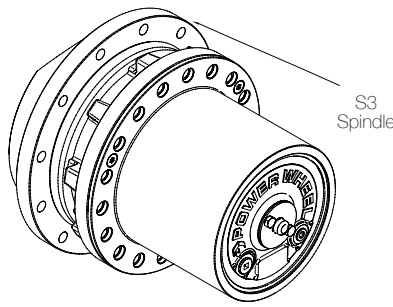

M7 Motor Mount

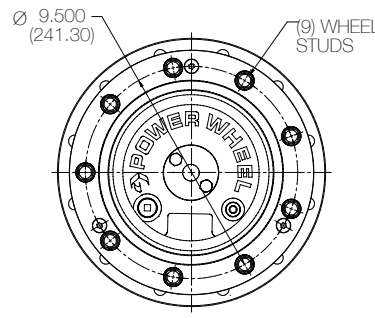
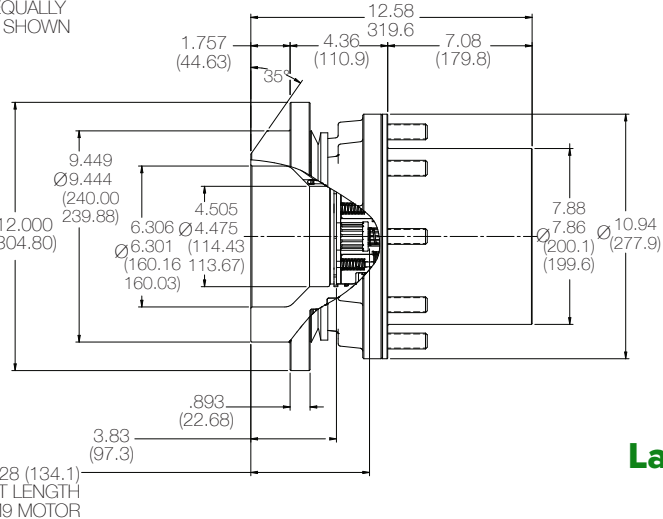
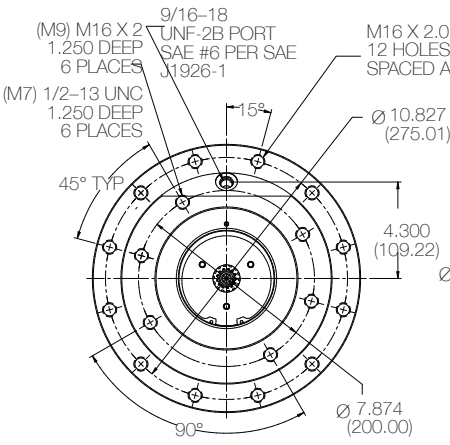

Large Cavity Motors

Power Wheel® Model 161CD Compact Final Drive

General Specifications

Max. intermittent output torque^{1,2}160,000 lb-in (18,000 Nm)
 Max. input speed²5,000 RPM

Approximate Weight 250 lbs (113 kg)
 Oil capacity 70 oz (2100 cc)
 Max. radial load: (@ pref. load center)32,680 lbs (14,800 kg)

¹ Depending on the duty cycle and the nature of the application, a normal continuous output torque of 1/3 to 1/2 of the maximum Intermittent should yield satisfactory Power Wheel® life. Customer testing and application analysis is strongly recommended.

² If application exceeds published limit, contact Auburn Gear.

- M1 = DANFOSS H1 060, REXROTH A6VE 55
- M2 = DANFOSS H1 080
- M3 = DANFOSS 90 SERIES 55cc, Hydro Leduc MSI50
- M4 = BOSCH A6VE 80
- C1 = SAE C MOUNT

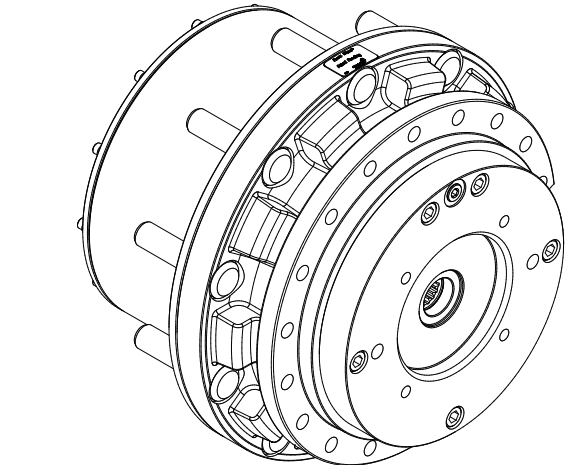
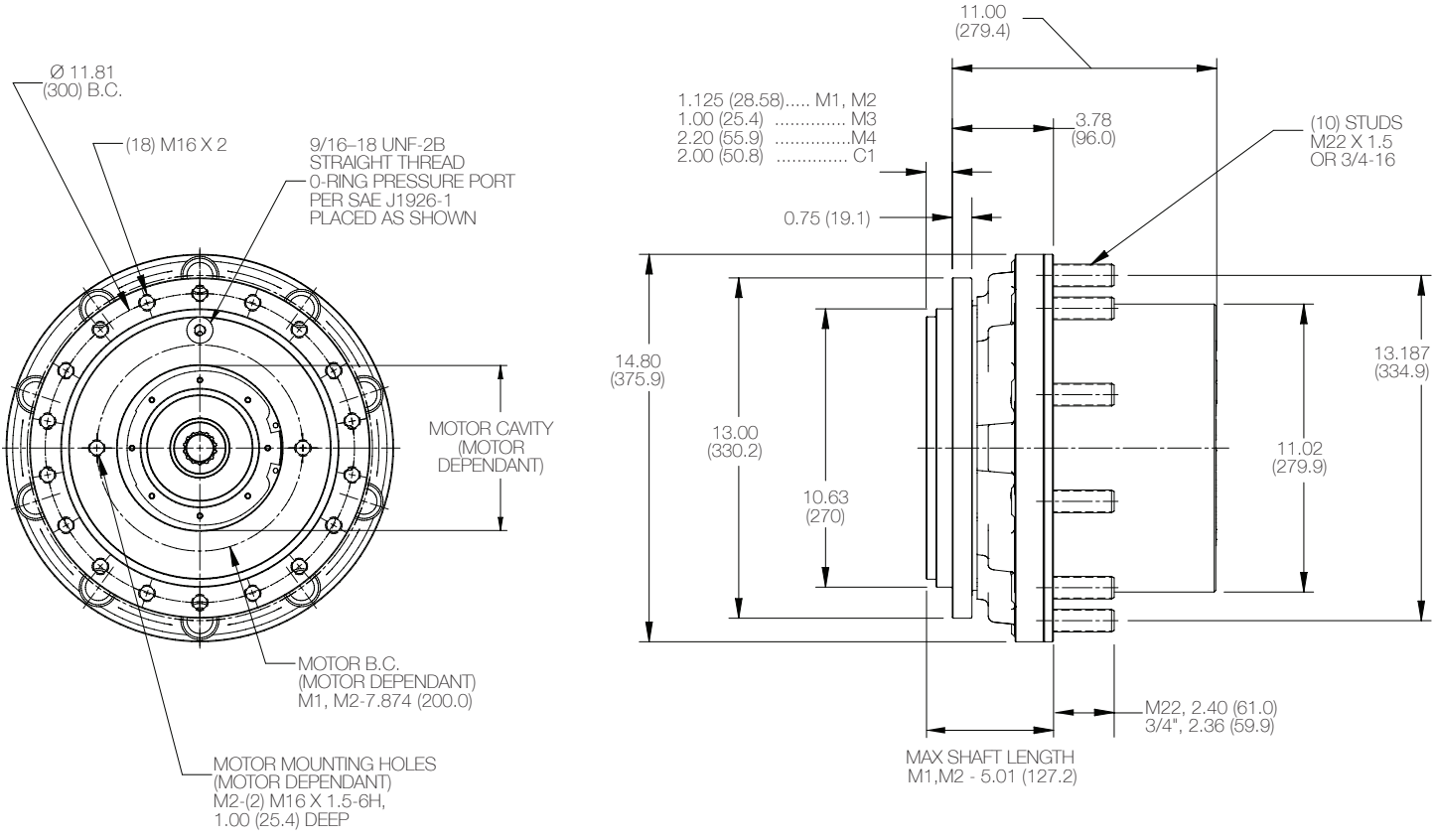

SAE C Motor Mount

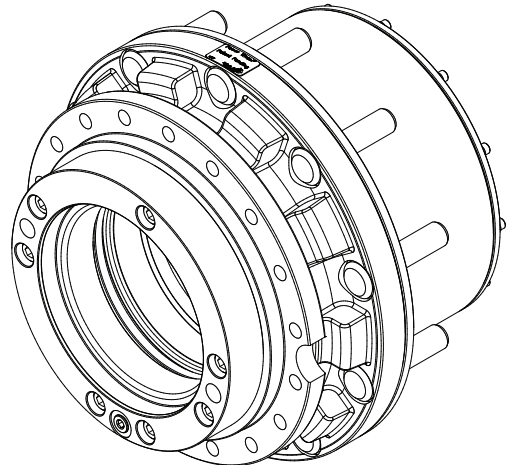

M4 Motor Mount

161CD

Model Formula

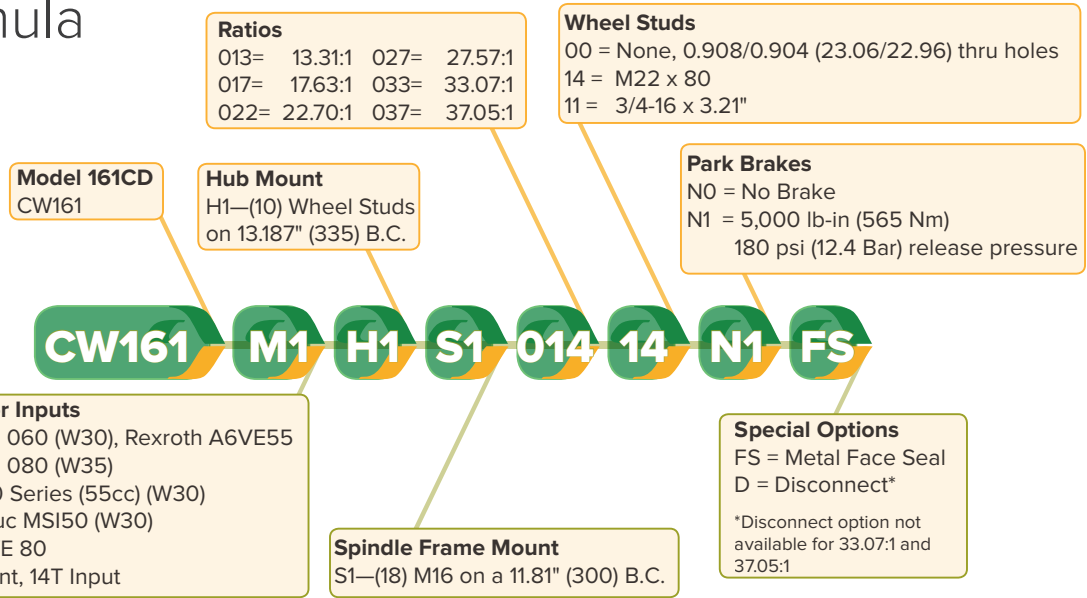

M4 Motor Mount

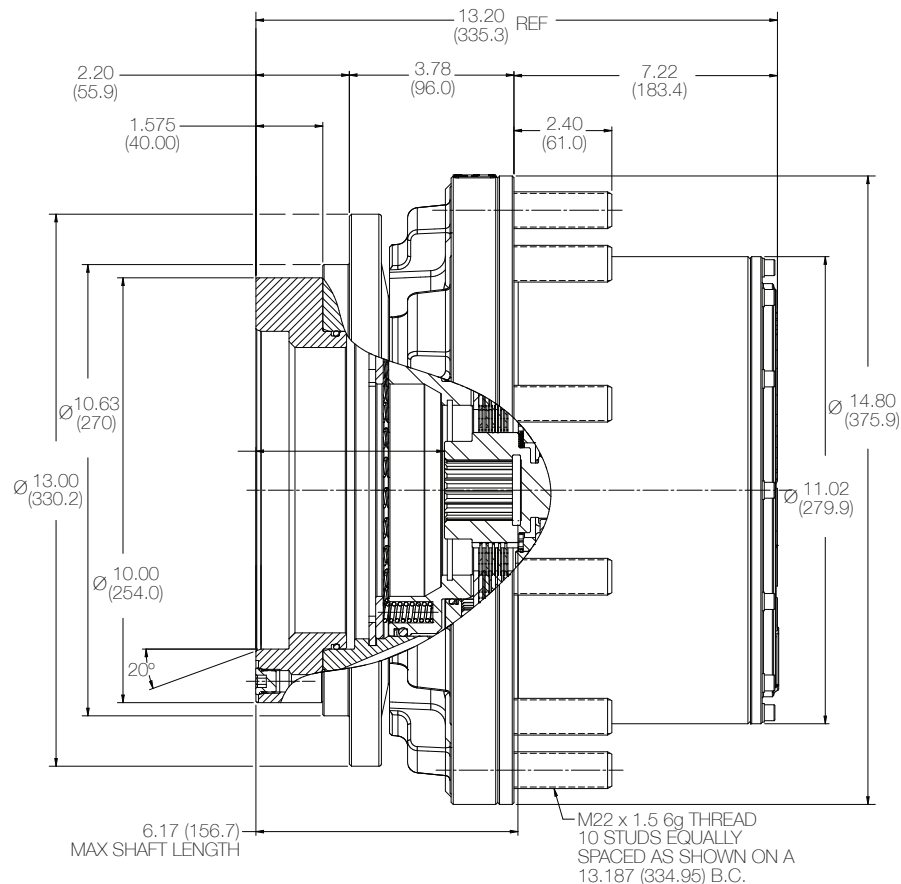
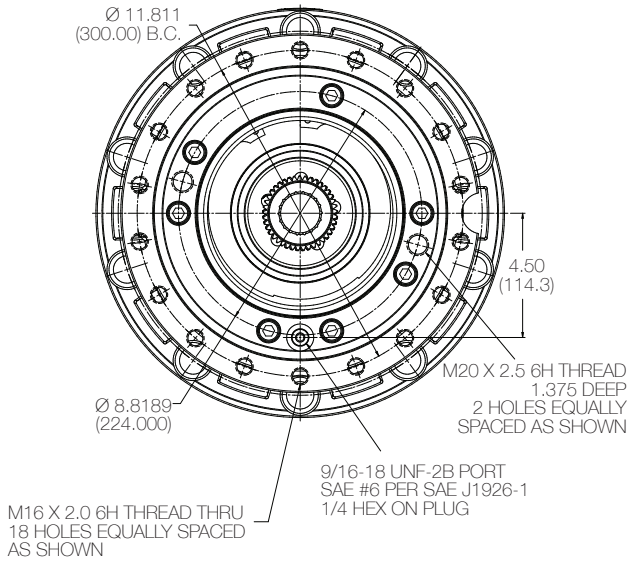

1800-OILSOL
1800-645765

<https://oilsolutions.com.au/>

sales@oilsolutions.com.au

Power Wheel® Model 160CD Compact Final Drive

General Specifications

Double Reduction

Max. intermittent output torque^{1,2}.....160,000 lb-in (18,000 Nm)
 Max. input speed²5,000 RPM
 Approximate Weight250 lbs (113 kg)
 Oil capacity70 oz (2100 cc)
 Max. radial load: (@ pref. load center)32,680 lbs (14,800 kg)

Triple Reduction

Max. intermittent output torque^{1,2}.....160,000 lb-in (18,000 Nm)
 Max. input speed²5,000 RPM
 Approximate Weight275 lbs (125 kg)
 Oil capacity80 oz (2400 cc)
 Max. radial load: (@ pref. load center)32,680 lbs (14,800 kg)

¹ Depending on the duty cycle and the nature of the application, a normal continuous output torque of 1/3 to 1/2 of the maximum Intermittent should yield satisfactory Power Wheel® life. Customer testing and application analysis is strongly recommended.

² If application exceeds published limit, contact Auburn Gear.

M1 = DANFOSS H1 060
 M2 = DANFOSS H1 080
 M3 = DANFOSS 90 SERIES 55cc, Hydro Leduc MSI50
 M4 = BOSCH A6VE 80
 C1 = SAE C MOUNT

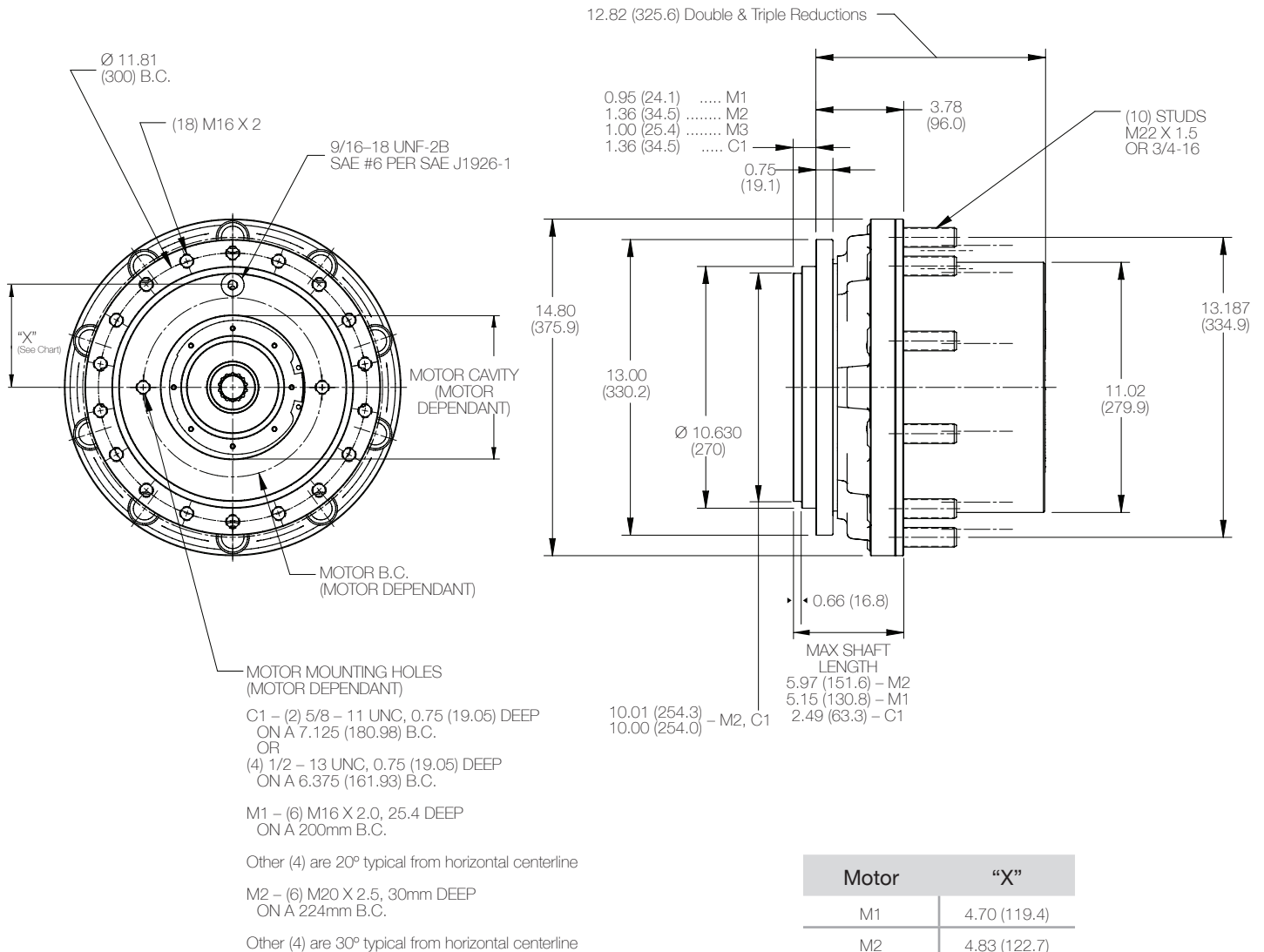

160CD

Model Formula

Ratios
 041 = 41.88:1 094 = 94.16:1
 015 = 15.20:1 051 = 51.10:1 112 = 112.12:1
 018 = 18.51:1 060 = 60.95:1 138 = 138.35:1
 022 = 22.41:1 072 = 72.57:1 199 = 199.0:1
 027 = 27.20:1 077 = 77.32:1 239 = 239.70:1
 032 = 32.30:1 086 = 86.74:1

Wheel Studs
 00 = None, 0.908/0.904 (23.06/22.96) thru holes
 14 = M22 x 80
 11 = 3/4-16 x 3.21"

Model 160CD
 CW160

Hub Mount
 H1—(10) Wheel Studs on 13.187" (335) B.C.
 H2—(18) M16x2, 38.1 DEEP on 12.99 (330) B.C.

Park Brakes
 N0 = No Brake
 N1 = 5,000 lb-in (565 Nm)
 150 psi (10.3 Bar) release pressure

CW160 M1 H1 S1 041 14 N1 Q

Cartridge Motor Inputs
 M1—Danfoss H1 060 (W30), Rexroth A6VE 55
 M2—Danfoss H1 080 (W35)
 M3—Danfoss 90 Series (55cc) (W30)
 —Hydro Leduc MS150 (W30)
 M4—Bosch A6VE 80
 C1—SAE C Mount, 2 or 4 bolt 14T Input

Spindle Frame Mount
 S1—(18) M16 x 2 on a 11.81" (300) B.C.

Special Options
 FS = Metal Face Seal
 Q = Quick Disconnect

SAE C Motor Mount

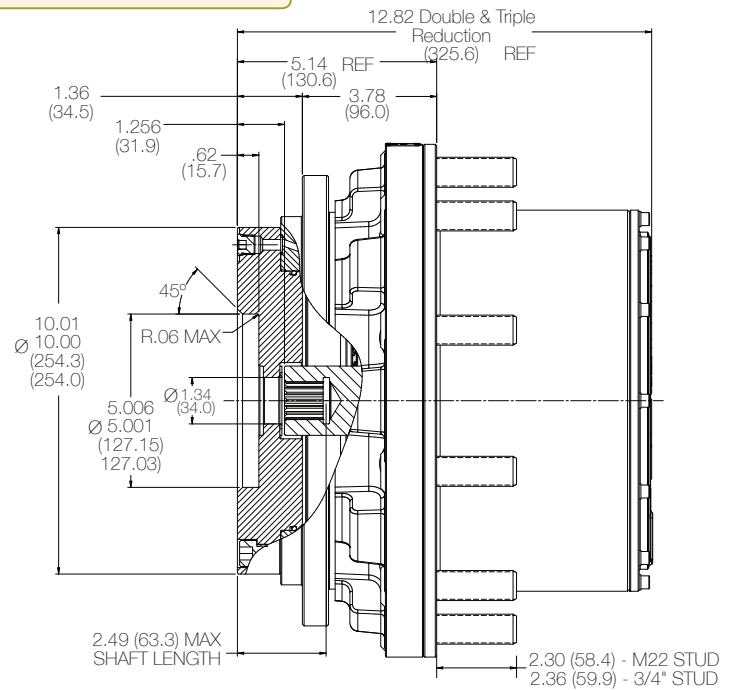
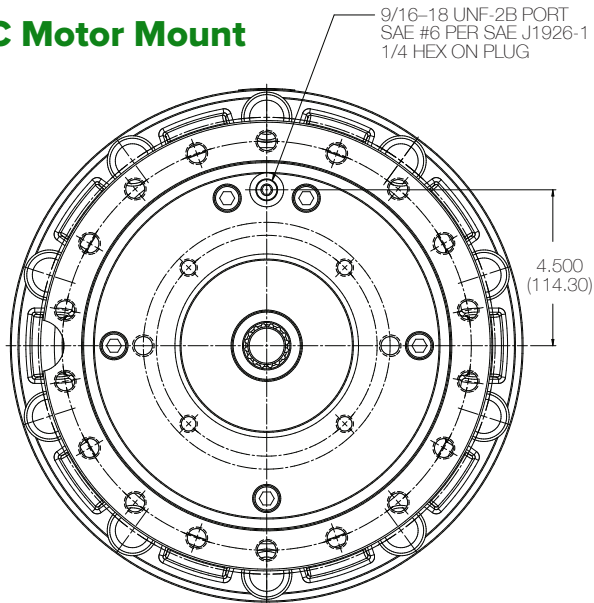

M1 Motor Mount

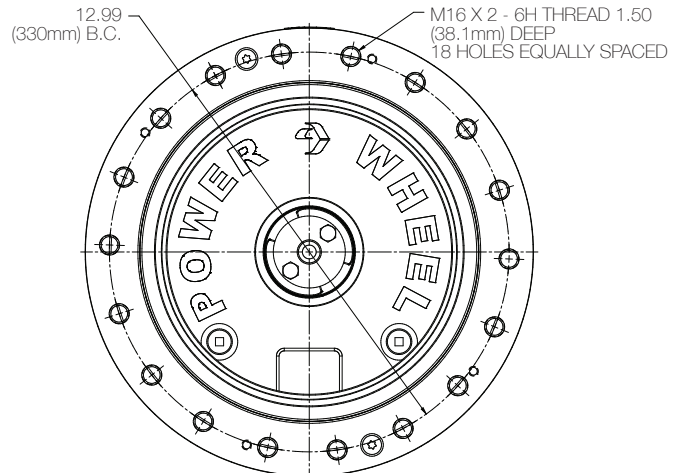
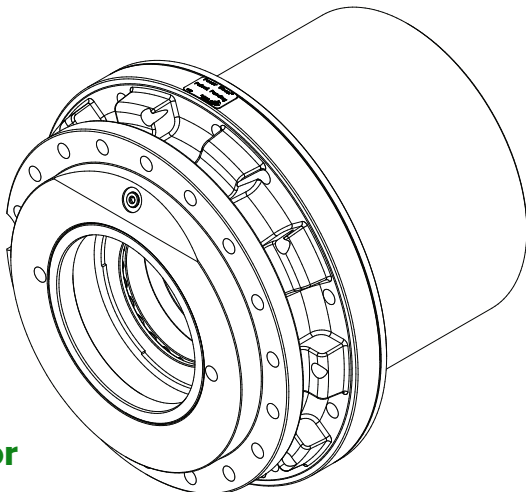

H2 Hub Configuration



1800-OILSOL
 1800-645765

<https://oilsolutions.com.au/>

sales@oilsolutions.com.au



Providing Technology, Quality & Customer Support Around the Globe



ISO 9001-2008 Certified



1800-OILSOL
1800-645765

<https://oilsolutions.com.au/>

sales@oilsolutions.com.au