

# AuburnGear

Engineered Drive Solutions

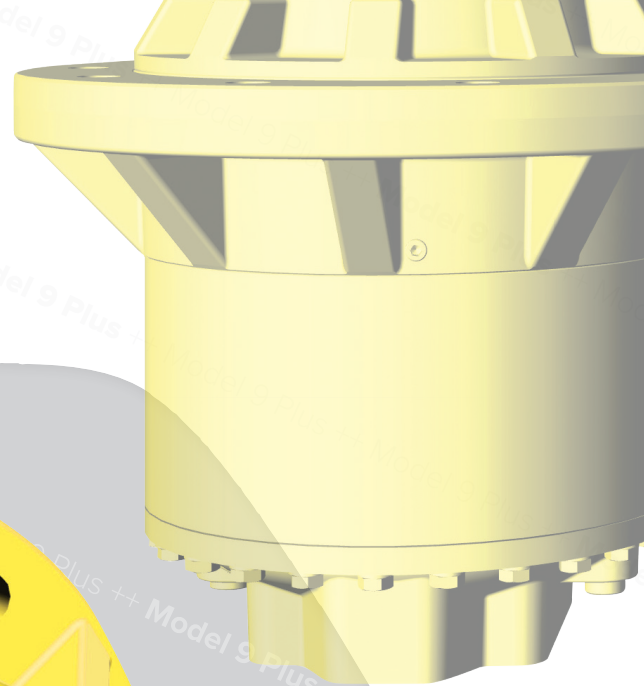
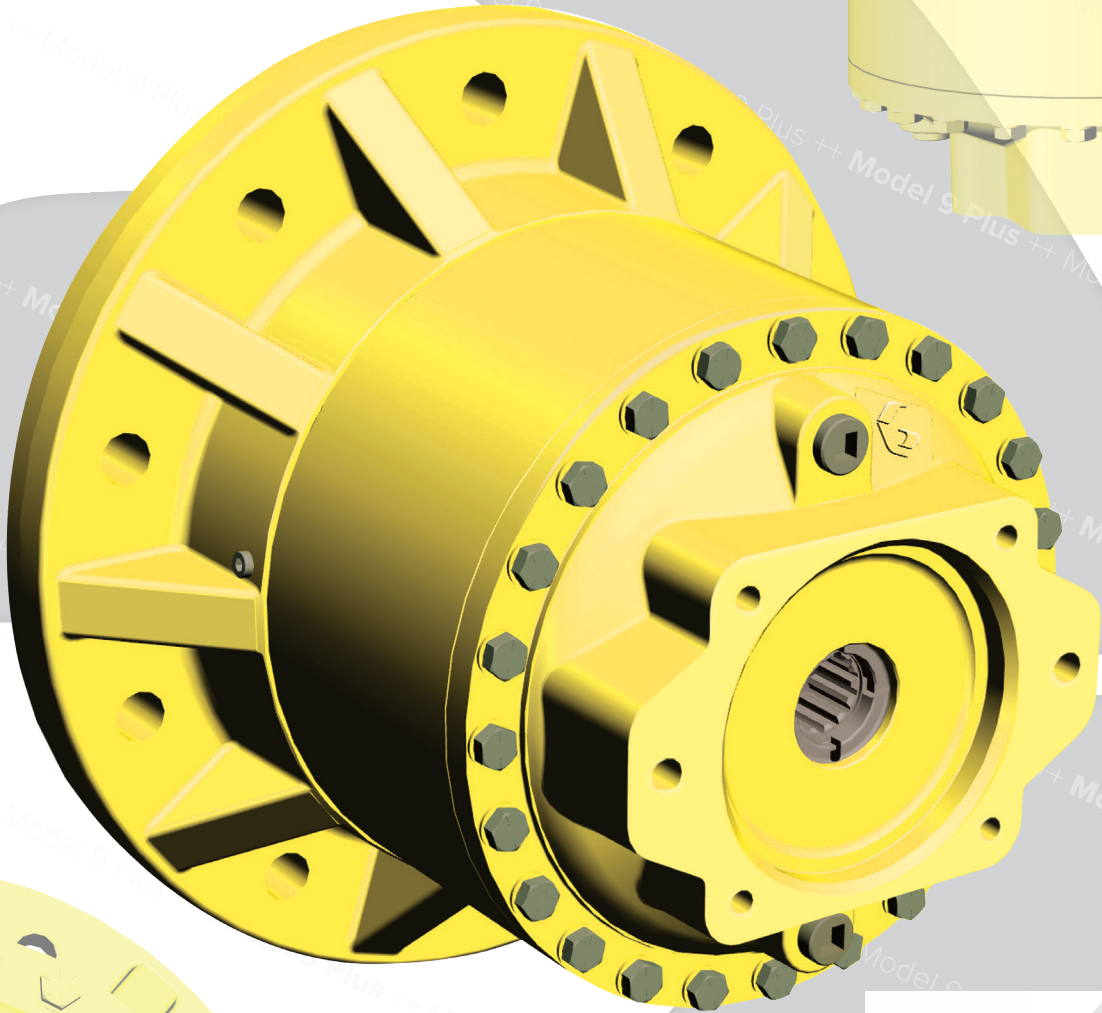

OIL SOLUTIONS

PO Box 38  
Strathfieldsaye, VIC, 3551  
1800 OIL SOL  
1800 645 765

[sales@oilsolutions.com.au](mailto:sales@oilsolutions.com.au)

[www.oilsolutions.com.au](http://www.oilsolutions.com.au)

"For All Your Hydraulic Needs"

**Power Wheel®**  
Model 9 Plus Spindle Output Drives

260.925.3200 AuburnGear.com

# Model 9 Plus Spindle Output Single & Double Reduction

Power Wheel®

## General Specifications

### Single Reduction

Max. intermittent output torque<sup>1,2</sup> .....78,000 lb-in (8,800 Nm)  
 Max. input speed<sup>2</sup> (w/o park brake) .....3,500 RPM  
 Max. input speed<sup>2,3</sup> (w park brake) .....3,500 RPM  
 Approximate Weight .....230 lbs (105 kg)  
 Oil capacity ..... 50 oz (1500 cc)  
 Max. radial load: (@ pref. load center) .....30,000 lbs (13,600 kg)

### Double Reduction

Max. intermittent output torque<sup>1,2</sup> .....130,000 lb-in (14,700 Nm)  
 Max. input speed<sup>2</sup> (w/o park brake) .....5,000 RPM  
 Max. input speed<sup>2,3</sup> (w park brake) .....3,600 RPM  
 Approximate Weight .....265 lbs (120 kg)  
 Oil capacity ..... 60 oz (1800 cc)  
 Max. radial load: (@ pref. load center) .....30,000 lbs (13,600 kg)

<sup>1</sup> Depending on the duty cycle and the nature of the application, a normal continuous output torque of 1/3 to 1/2 of the maximum intermittent should yield satisfactory Power Wheel® life. Customer testing and application analysis is strongly recommended.

<sup>2</sup> If application exceeds published limit, contact Auburn Gear.

<sup>3</sup> Bolt-on and A2 series parking brakes available. Please contact Auburn Gear if required.



1800-OILSOL <https://oilsolutions.com.au/>  
 1800-645765

[sales@oilsolutions.com.au](mailto:sales@oilsolutions.com.au)

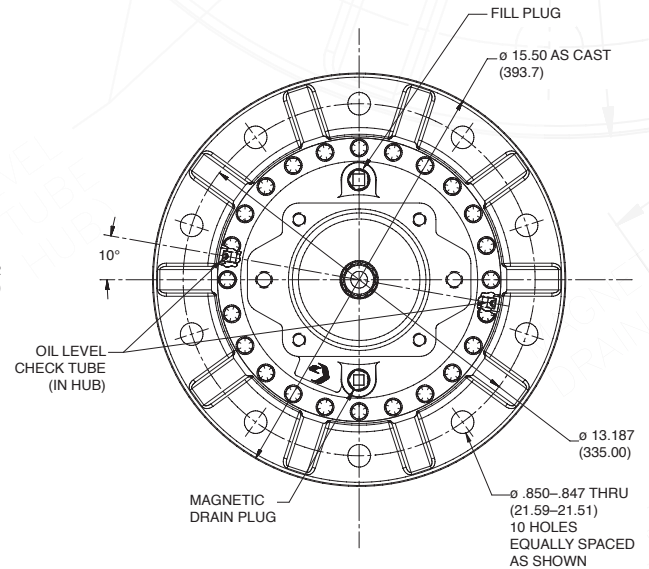
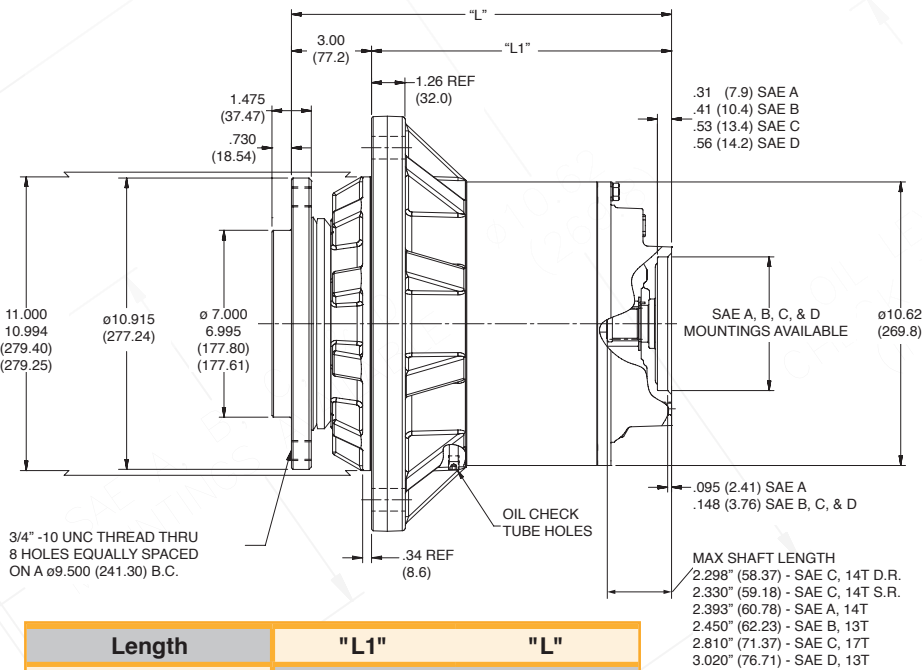

Length	"L1"	"L"
SAE A Single Red.	9.34 (237.2)	12.35 (313.7)
SAE A Double Red.	11.32 (287.5)	14.33 (364.0)
SAE B Double Red.	10.01 (254.3)	13.02 (330.7)
SAE C Single Red.	9.25 (235.0)	12.26 (311.4)
SAE C Double Red.	11.23 (285.2)	14.24 (361.7)
SAE D Double Red.	11.98 (304.3)	14.99 (380.8)

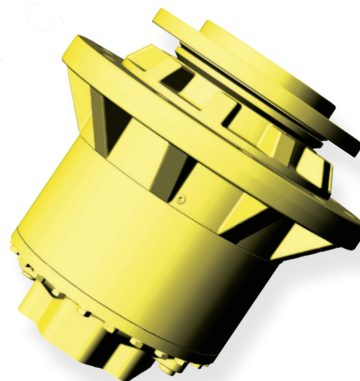

## FEATURE CHART: MODEL 9 PLUS SPINDLE OUTPUT SINGLE AND DOUBLE REDUCTION

OPTIONS	DESCRIPTION	MAKE ALL SELECTIONS WITHIN ONE COLUMN	ORDER CODES	USE OPTION ORDER CODES TO BUILD PART NUMBER	
BASE MODEL	9 Plus Single	•	9T		
	9 Plus Double	• • • •	9S	9S	
MOTOR PILOT/HUB	SAE A - A3	•	A3		
	SAE B - B3	•	B3		
	SAE C - C3	• •	C3		
	SAE D - D3	•	D3	D3	
INPUT SPLINE	13T 16/32	•	13		
	14T 12/24	•	14		
	17T 12/24	•	17		
	13T 8/16	•	13	13	
RATIO OPTIONS	SINGLE	4.86:1	•	04	
		6.00:1	•	06	
	DOUBLE	15.39:1	• •	15	
		18.83:1	• • • •	18	
		23.59:1	• •	23	23
		26.71:1	• •	26	
		31.50:1	• •	31	
		35.20:1	• •	35	
42.42:1	• •	42			
50.00:1	• •	50			
SPINDLE OPTION	(8) 3/4"-10 on a 9.50" BC	• • • •	F7	F7	
OTHER OPTIONS	Boot Seal	• • • •	Z	Z	
STD FEATURE	Large Taper Roller Bearing Set	• • • •	X	X	
Select desired characteristics from chart, note correct order codes, and order using sample format shown at right:				9S D3 13 23 F7 Z X	

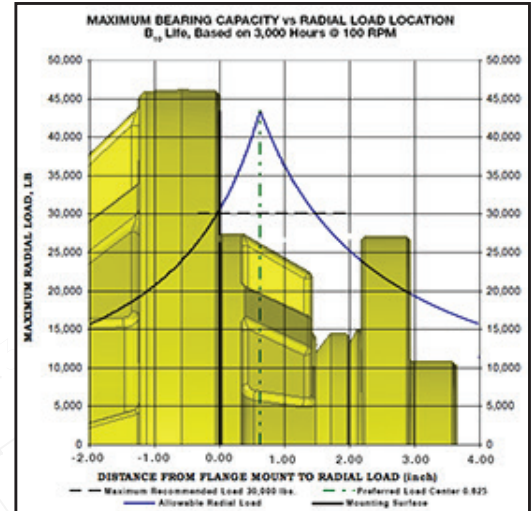

**NOTE:**

These curves are supplied as a design guide and apply to resultant radial load only. They indicate the importance of maintaining wheel position over the bearing center.

For actual analysis, applications should be reviewed by Auburn Gear Engineering using data supplied on Application Data Form.

### BEARING LOAD, LIFE AND SPEED RELATIONSHIPS

$$LF = \frac{SF \times R}{R'}$$

R = Allowable resultant load for given location from mounting flange

R' = Anticipated load at location from mounting flange

LF = Life Factor from table (see below)

SF = Speed Factor from table (see below)

OUTPUT SPEED (RPM)	SF	BEARING HOURS B-10 LIFE	
		LF	
5	2.456	.584	500
10	1.994	.719	1000
20	1.620	.812	1500
30	1.435	.886	2000
40	1.316	.947	2500
50	1.231	1.000	3000
60	1.165	1.047	3500
70	1.113	1.090	4000
80	1.069	1.130	4500
90	1.032	1.166	5000
100	1.000	1.231	6000
200	.812	1.289	7000
300	.719	1.342	8000
400	.659	1.390	9000
500	.617	1.435	10000

**CAUTION:** The same torsional loading constraints used in the driving mode must be used in the braking mode when braking through the **Power Wheel** drive gear set.

### MOTOR MOUNTING CHART

MOTOR MOUNTING HOLE DIMENSIONS	DIAMETER
<b>SAE A</b> (4)– 1/2" -13 UNC, -2B Thd Holes on 4.188 (106.38) B. C.*	ø 3.251 - 3.256 (82.58 - 82.70)
<b>SAE B</b> (2)– 1/2" -13 UNC, - 2B Thd Holes on 5.750 (146.05) B. C.*	ø 4.001 - 4.006 (101.62 - 101.75)
<b>SAE C</b> (4)– 1/2" -13 UNC, -2B Thd Holes on 6.375 (161.93) B. C.*	ø5.001 - 5.006 (127.02 - 127.15)
<b>OR</b> (2)– 5/8" -11 UNC -2B Thd Holes on 7.125 (180.98) B. C.*	
<b>SAE D</b> (4)– 3/4" -10 UNC, - 2B Thd Holes on 9.000 (228.60) B. C.*	ø 6.001 - 6.006 (152.43 - 152.55)

\* "O" RING OR GASKET REQUIRED (Not Supplied by Auburn Gear)

"O" RING SIZES: SAE "A" 2-042, SAE "B" 2-155, SAE "C" 2-159, SAE "D" 2-163



1800-OILSOL  
1800-645765

<https://oilsolutions.com.au/>

sales@oilsolutions.com.au

# Power Wheel® Model 9 Plus Spindle Output Drives

Providing Technology, Quality & Customer Support Around the Globe



ISO 9001-2008 Certified



OIL SOLUTIONS

1800-OILSOL  
1800-645765

<https://oilsolutions.com.au/>

[sales@oilsolutions.com.au](mailto:sales@oilsolutions.com.au)