

Rexroth Connection System fibre optic cables

R911284755
Edition 02

Description



- Title** Indramat Internal Connection System
Fiber Optic Cable (LWL) Handling
- Type of documentation** Application Description
- Documentation code** DOK-CONNEC-CABLE*LWL**-AW02-EN-P
- Internal file reference**
- Drawing number: 120-0300-B303-02/EN
 - Replace drawing number: 209-0090-4101-06/EN01.96
- What is the purpose of this document?** The following documentation describes
- an Application Description

Course of modifications

Document identification of previous and present output	Release Date	Comments
DOK LWL-Handling ANWE EN	01.96	1 st edition
DOK-CONNEC-CABLE*LWL**-AW02-EN-P	07.99	revision

Copyright © INDRAMAT GmbH, 1999

Transmission as well as reproduction of this documentation, commercial use or communication of its contents will not be permitted without expressed written permission. Violation of these stipulations will require compensation. All rights reserved for the issuance of the patent or registered design. (DIN 34-1)

Validity All rights are reserved with respect to the content of this documentation and the availability of the product.

Published by INDRAMAT GmbH • Bgm.-Dr.-Nebel-Str. 2 • D-97816 Lohr a. Main
Telephone 09352/40-0 • Tx 689421 • Fax 09352/40-4885
Dept. ECM4/ECM5 (PK/SK)

Note This document has been printed on chlorine-free bleached paper.

Table of Contents

1	Fiber Optic Cable (LWL) – General Information	1-1
1.1	Introduction.....	1-1
1.2	LWL Cables.....	1-2
2	Selection List of Standard Plastic LWLs	2-1
2.1	Ready-to-attach LWLs Ø 2,2 mm	2-1
2.2	Ready-to-Attach LWLs Ø 6.0 mm	2-3
3	FSMA Selection List for Plug-In Connectors and LWLs	3-1
3.1	FSMA Connectors for cables Ø 2.2 mm	3-1
3.2	FSMA connector for cable Ø 6.0 mm.....	3-1
3.3	LWL Accessories and Leadthroughs	3-2
3.4	LWL Leadthroughs	3-2
3.5	Protective Caps for LWL Connectors or Leadthroughs	3-2
4	Routing Guidelines for LWLs	4-1
5	Technical Data	5-1
5.1	Technical Data LWL – cable Ø 2.2 mm type INK0414	5-1
5.2	Technical Data LWL – cable Ø 6.0 mm type INK0435	5-2
5.3	Technical Data LWL – cable Ø 3.0 mm type INK0436	5-3
6	Attenuation Measurements of the Standard Plastic LWLs	6-1
6.1	LWLs	6-1
6.2	Measuring Procedure.....	6-2
	1 st Reference:.....	6-2
	2 nd Attenuation:.....	6-2
6.3	Maximum Allowed Cable Attenuation	6-3
6.4	Converting Optic Transmission Power (dBm < -- > µW).....	6-4
7	Assembly Guidelines	7-1
7.1	Assembly Guideline for FSMA connector Ø 2.2 mm	7-1
7.2	Assembly Guideline for FSMA connector Ø 6.0 mm	7-4
8	Tools for Assembly LWLs	8-1
8.1	Overview	8-1
8.2	Test Tools for LWLs	8-2

9	Index	9-1
10	Kundenbetreuungsstellen - Sales & Service Facilities	10-1

1 Fiber Optic Cable (LWL) – General Information

1.1 Introduction

The use of fiber optic cables, hereinafter called LWLs, has numerous advantages over conventional copper leads. Just in terms of EMC features alone (electro-magnetic compatibility) LWL signal transmission offers the greatest possible safety.

The LWLs used by INDRAMAT are available both as raw cables and standard, ready-to-use cables. All leads and connectors meet the demands specified by the SERCOS interface (IEC 61491 or EN 61491) standard.

This document is intended to support the user when assembling and dimensioning LWLs.

Note: The setting for the best transmission power and the associated cable lengths are specified in the documentation of the unit (Project Planning or Application Description manuals).

The standard LWLs manufactured by Indramat will support operation. Using this document it is, however, possible to make individual components. All those components specified by Indramat such as cable and connectors are joint developments of INDRAMAT and carefully selected manufacturers and are subject to continuous manufacturing and quality control processes.

Note: Standard LWL components not recommended by INDRAMAT should not be used if the intention is to make components.

2 Selection List of Standard Plastic LWLs

2.1 Ready-to-attach LWLs \varnothing 2,2 mm

Note: Ready-to-attach LWLs may only be used in the control cabinet or inside the unit.

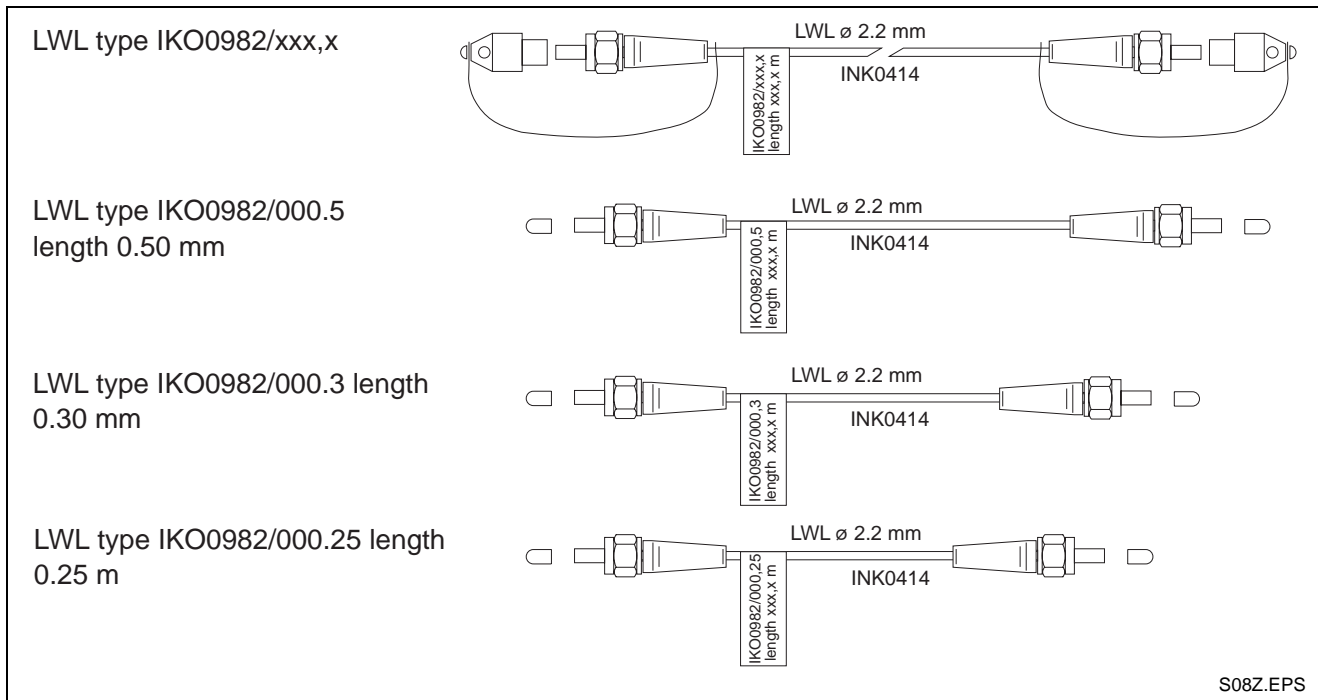

Fig. 2-1: Ready-to-attach LWLs \varnothing 2.2 mm

Note: Cables IKO0982/000.25 and IKO0982/000.3 may only be used to connect units (no additional coupling locations). Allowed cable attenuation equals max. 5.0 dB.

How to order: From the above illustration select the connections needed, (e.g., order type IKO0982/xxx,x). Also specify the length of the cable as shown below.

Available cable lengths:

0.25m	IKO0982/000.25
0.30 m	IKO0982/000.3
0.50 m	IKO0982/000.5
any	IKO0982/xxx.x

Order text for cable length of 5.5 meters.

IKO0982/005.5

Note: Maximum total length equals 40 m.

2.2 Ready-to-Attach LWLs \varnothing 6.0 mm

LWL cable type IKO0985/xxx,x.

(For routing within machine area – suited for trailing cable installation.)

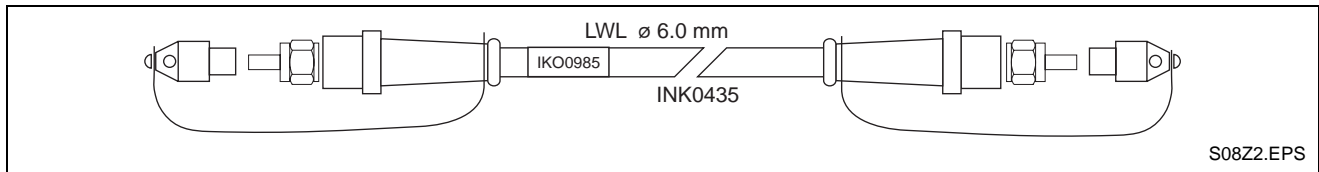

Fig. 2-2: Ready-to-attach LWLs \varnothing 6.0 mm

How to order: Select the connection needed from the above illustration, e.g., order type IKO0985/xxx,x. The length of the cable must also be specified as shown.

Available cable lengths:

5.0 m	IKO0985/005.0
10.0m	IKO0985/010.0
15.0 m	IKO0985/015.0
20.0 m	IKO0985/020.0
any	IKO0985/xxx,x

Order text for a cable length of 5.5 m:

IKO0985/005.5

3 FSMA Selection List for Plug-In Connectors and LWLs

3.1 FSMA Connectors for cables \varnothing 2.2 mm

Type INS0420

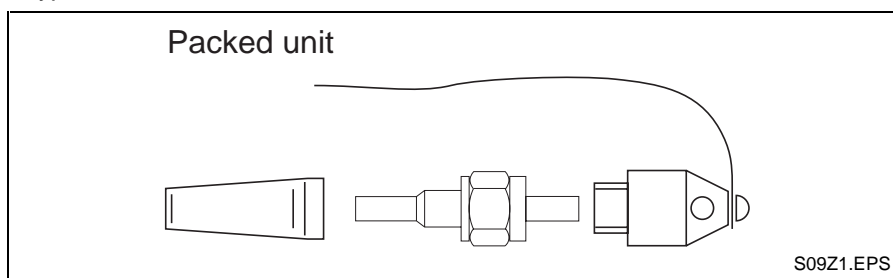

Fig. 3-1: Packaging unit 2.2 mm

The LWL which can be used

type INK0414

Note: LWLs with 2.2 mm \varnothing may only be used in the control cabinet or inside the unit!

3.2 FSMA connector for cable \varnothing 6.0 mm

Type INS0425

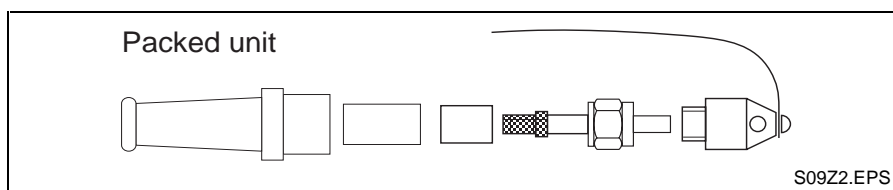

Fig. 3-2: Packaging unit 6.0 mm

LWL which can be used in a trailing cable installation.

type INK0435

Note: LWLs with \varnothing 6.0 mm can be used in trailing cable installations.

3.3 LWL Accessories and Leadthroughs

3.4 LWL Leadthroughs

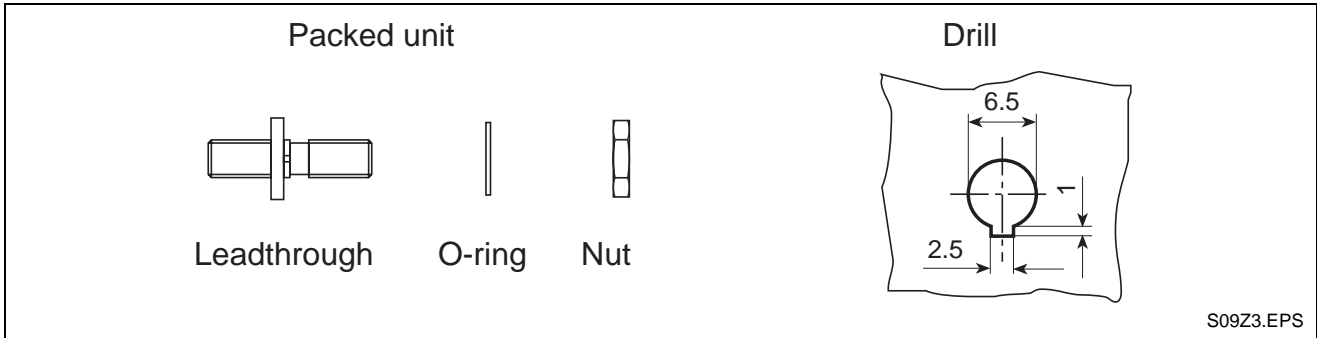

Fig. 3-3: Packaging unit LWL leadthrough

3.5 Protective Caps for LWL Connectors or Leadthroughs

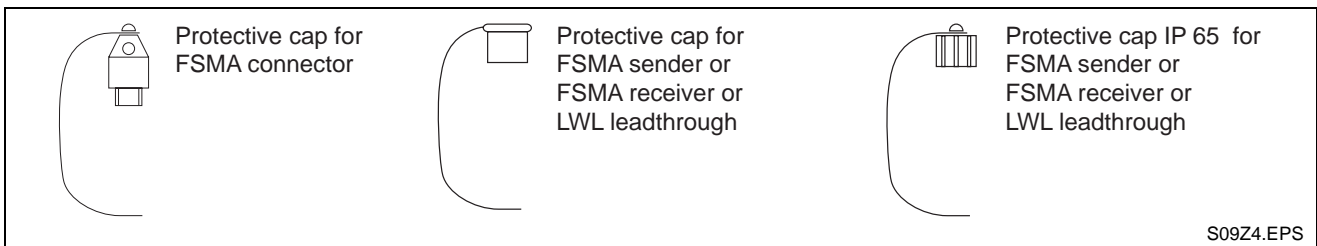

Fig. 3-4: Accessories

4 Routing Guidelines for LWLs

When routing and inserting LWLs it must basically be noted that specific load data may not be exceeded.

Inserting and routing LWLs To insert a standard LWL it is possible and if necessary to thread twine or a wire through the lateral drill hole of the protective cap (may not, however, cut into the hole). It is first necessary to remove the latch from protective cap and LWL.

Maximum tensional force between connector and LWL may not be exceeded when doing this.

The minimum bend radius (even if pulled around corners) may not be exceeded.

Once inserted, the latch of the protective cap must be remounted.

Avoid routing over sharp edges or spiky uneven surfaces. Any cuts or other types of mechanical damage can lead to problems and breakdowns.

Transverse loads Maximum transverse resistance (even if pulled around corners) may not be exceeded.

Torsion Avoid twisting an LWL when routing. In every case, make sure that there is no tension at the end position.

Also note DIN VDE 0899, section 4.

5 Technical Data

5.1 Technical Data LWL – cable \varnothing 2.2 mm type INK0414

Designation	INK0414
External mantle:	Polyamide
External diameter:	2.2 ± 0.07 mm
Bend radius short-term*:	> 30 mm (360°)
bend radius continuous:	> 50 mm (360°)
Tensile strength short-term:	< 150 N
Tensile strength continuous:	< 100 N
Tensile strength connector – cable:	< 50 N
Tensile strength protective cap – connector:	< 240 N
lateral resistance to pressure:	450 N/cm (60 sec.) upto 1250 loads (cycles)
resistance to alternating bend loads:	> 8000 cycles \geq 90°, r = 20 mm, tensile force 2 N
Temperature range for storage:	- 40°C... + 85°C
Temperature range for operations:	- 20°C... + 70°C
core diameter:	1000 μ m ± 20 μ m
Specific attenuation:	< 0.2 dB/m at 650 n/m
Bend attenuation	additionally about 0.2 dB/m at 10 windings with r = 50 mm

Fig. 5-1: Overview of Technical Data INK0414

* While routing, not during operations!

5.2 Technical Data LWL – cable \varnothing 6.0 mm type INK0435

This LWL (type INK0435) is suited for cable installations.

Note: When routing and inserting LWLs always ensure that the specific load data are not exceeded.

Designation	INK0435
External mantle:	PUR
External diameter:	6.0 ± 0.2 mm
bend radius short-term*:	> 30 mm
bend radius continuous:	> 80 mm
bend radius continuous in cable track:	> 100 mm
Tensile strength:	100 N
Tensile strength connector – cable:	< 100 N
Tensile strength protective cap – connector:	< 240 N
lateral resistance to pressure:	100 N/cm
resistance to alternating bend loads:	> 100000 cycles ± 90°; r=100 mm, tensile force 2 N
Temperature range for storage:	- 20°C... + 70°C
Temperature range for operations:	- 0°C... + 70°C
core diameter (Fiber):	1000 µm ± 20 µm
Specific attenuation:	< 0.2 dB/m at 650 n/m
Bend attenuation:	additional 0.2 dB/m at 10 windings; at r = 50 mm

Fig. 5-2: Overview of Technical Data INK0435

* While routing, not during operations!

Note: When inserting non-standard LWLs it may be necessary to expose the kevlar mantle and attached it to a tensile force wire.

5.3 Technical Data LWL – cable \varnothing 3.0 mm type INK0436

Designation	INK0436
External mantle:	polyurethane (PUR)
External diameter:	3,0 mm
bend radius short-term*:	> 25 mm
Tensile strength short-term:	330 N
Tensile strength continuous:	110 N
lateral resistance to pressure:	1000 N/cm
resistance to alternating bend loads:	> 10000 Cycles \pm 90°
Temperature range for storage:	- 40°C... + 85°C
Temperature range for operations:	- 40°C... + 85°C
core diameter optische Faser:	200 μ m
Specific attenuation:	< 10 dB/km

Fig. 5-3: Overview of Technical Data INK0436

* While routing, not during operations!

6 Attenuation Measurements of the Standard Plastic LWLs

- Equipment needed**
- LWL level oscillator e.g., 1XT from TS optoelectronic
 - LWL reference cable IKO0982/1
 - LWL measurement coupling
 - LWL level meter e.g., 4XT-S from TS optoelectronics with adapter TSO-2000-x for FSMA

To ensure the LWL transmission distances (see Fig. 6-1), it is necessary to determine the attenuation of all standard LWLs (intermediate distances).

Total attenuation of an LWL transmission distance (in dB) = sum of all individual attenuations (in dB).

6.1 LWLs

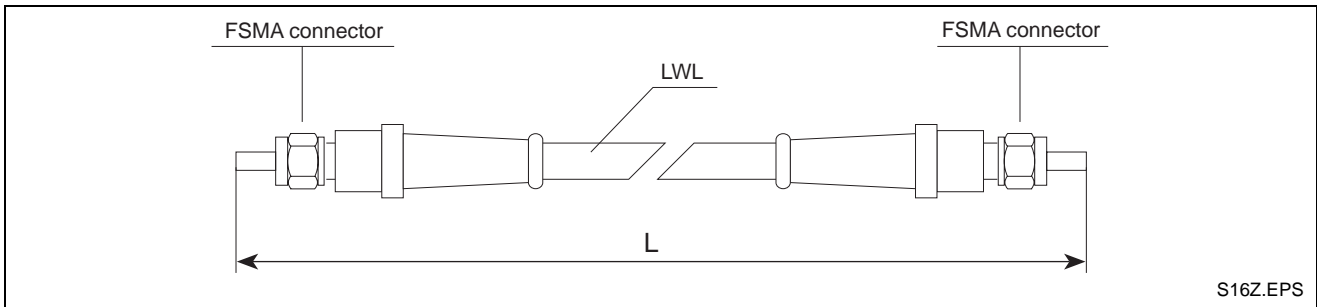

Fig. 6-1: LWL

$$A_{K_{max}} = a * L + A_s + P_F$$

Fig. 6-2: Maximum anticipated attenuation of standard LWLs

$A_{K_{max}}$:	max. anticipated cable attenuation	dB
a :	max. LWL lead attenuation	0.25 dB/m
L :	max. length of LWL in meters	m
A_s :	max. in/out coupling attenuation of both LWL plug-in connectors	1.5 dB
P_F :	finishing tolerances and test assembly	0.5 dB

Fig. 6-3: Legend

6.2 Measuring Procedure

The procedure is broken down into the referencing and attenuation measurements. Both are described below.

1st Reference:

⇒ LWL test sender, reference cable and LWL level meter must be connected as per Fig. 6-4.

⇒ Switch LWL test sender on.

The LED U_B OK (voltage monitor) has to light up.

⇒ Switch LWL level meter on.*

⇒ Set LWL level meter to dB.*

⇒ Set LWL once current LWL level meter attenuation is fixed to 0 dB.*

⇒ Separate reference cable from LWL level meter.

Do not switch LWL test sender and LWL level meter off.

* See instructions on LWL level meter.

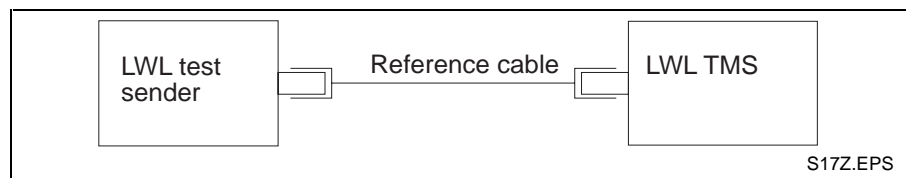

Fig. 6-4: Reference measurement

2nd Attenuation:

⇒ Connect LWL coupling, test piece and level meter to each other as per Fig. 6-5.

⇒ Read attenuation. The reading is the attenuation of the test piece.

⇒ Switch LWL test sender and level meter off.

⇒ Separate LWL coupling, test piece and level meter.

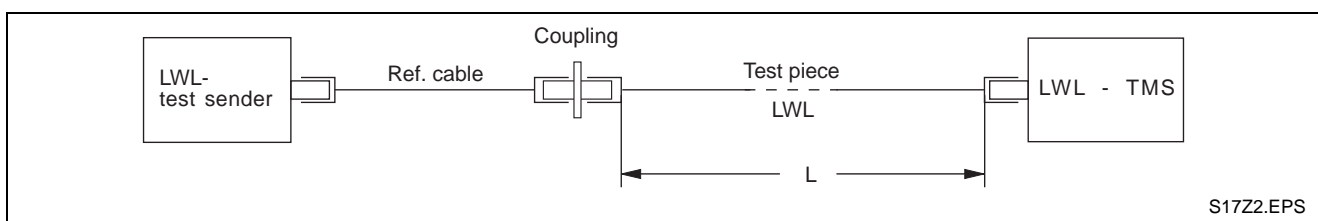

Fig. 6-5: Attenuation meter

Note: Reference measurement must be repeated prior to each measurement procedure. Maximum allowed cable attenuation equals 12.5 dB.

6.3 Maximum Allowed Cable Attenuation

The maximum allowed cable attenuation of the LWLs

IKO0982/xxx,x

IKO0985/xxx,x

can be determined using the following table.

The maximum allowed attenuation between sender and receiver (12.5 dB) is reached with a cable length of about 40 meters.

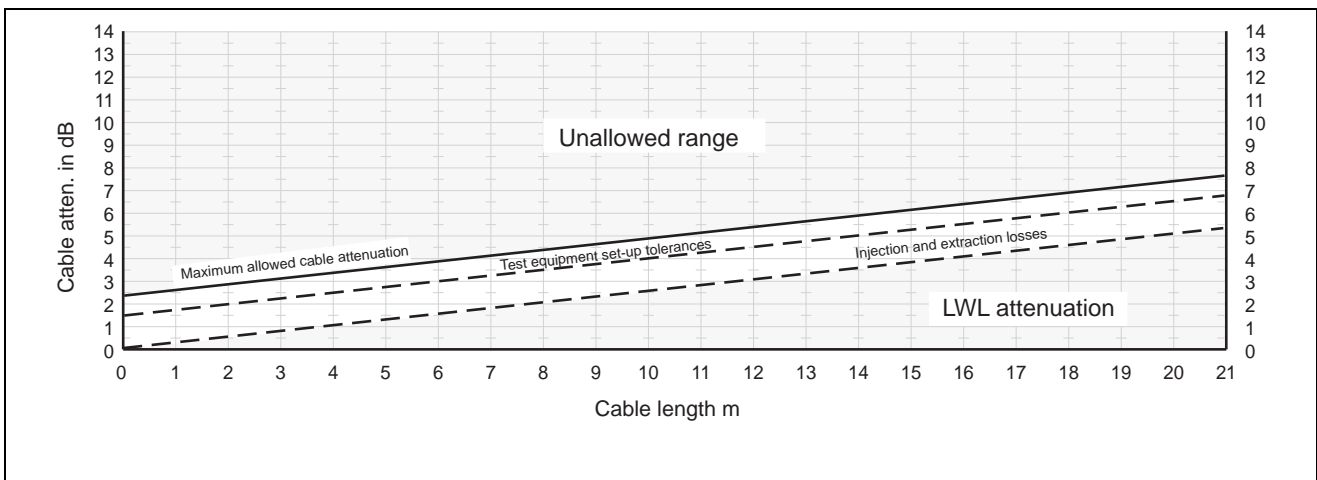

Fig. 6-6: Allowed cable attenuation

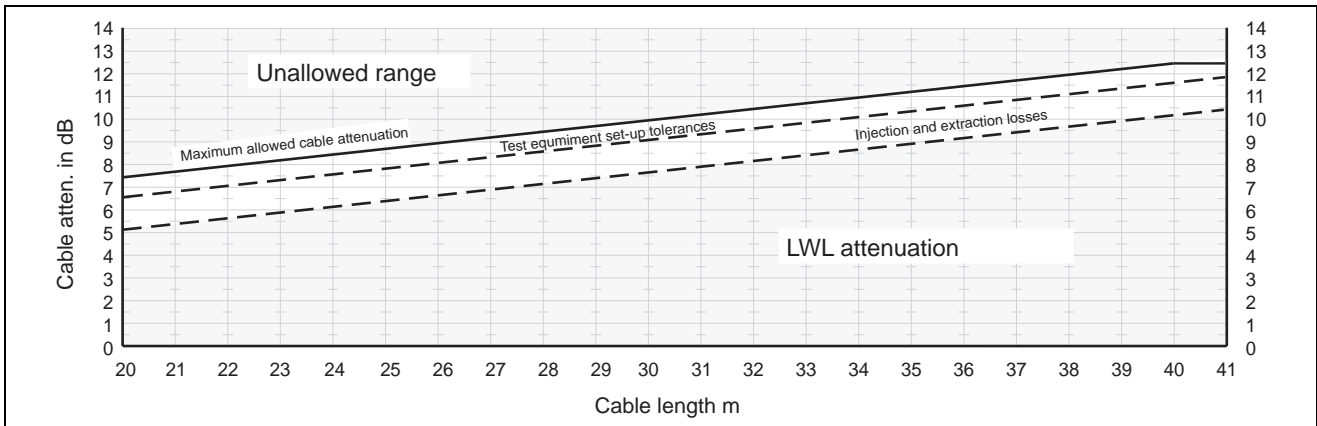

Fig. 6-7: Allowed cable attenuation

Exceptions:

With LWL cables **IKO0982/0.25**
 and **IKO0982/0.30**
 a maximum attenuation of 5 dB is allowed.

Note: Both cables may only be used to connect to pieces of equipment.

6.4 Converting Optic Transmission Power (dBm < -- > μW)

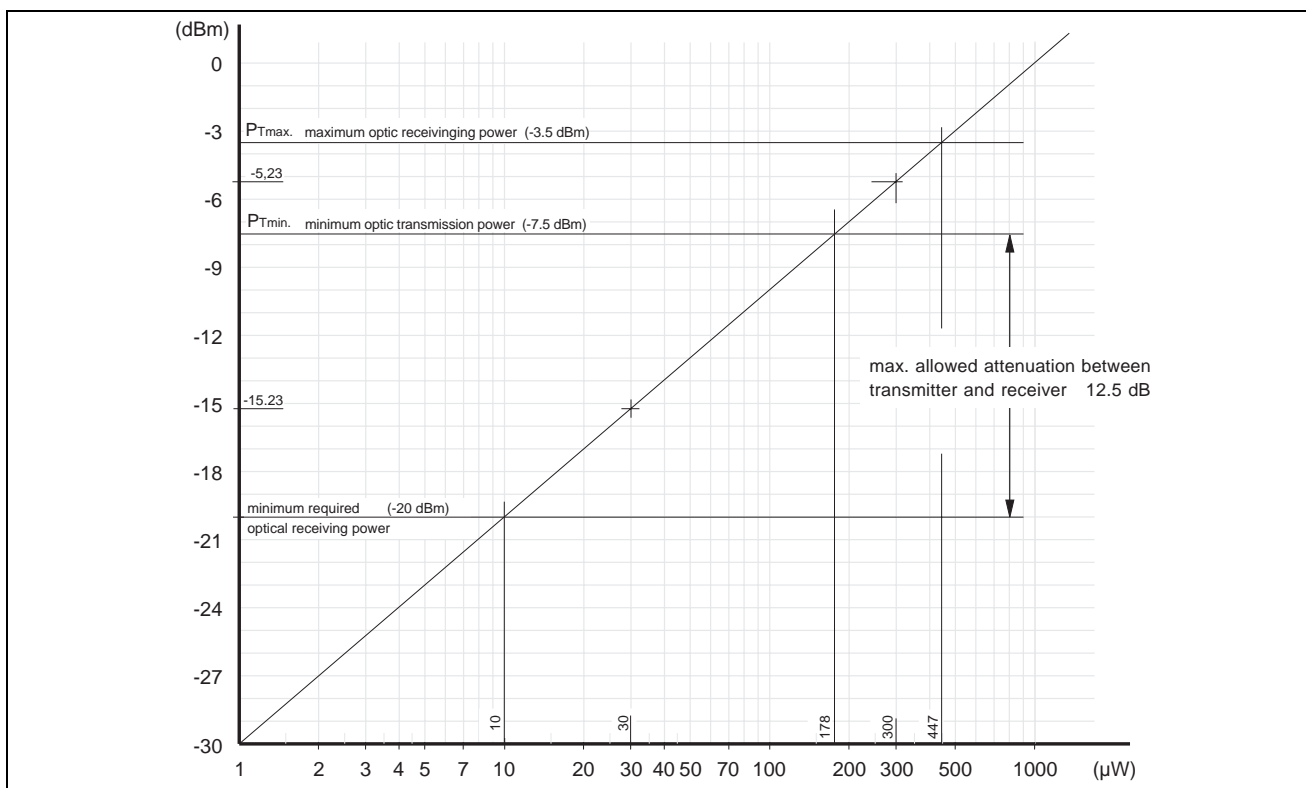

Fig. 6-8: Converting optic transmission power dBm < -- > μW

Optic transmission power	in dBm	in μW
P _{Tmax.} maximum transmission power	-3.5 dBm	447 μW
P _{Tmin.} minimum transmission power	-7.5 dBm	178 μW
P _{Rmin.} minimum receive power	-20 dBm	10 μW

Fig. 6-9: Optic transmission power

$$P_{(dBm)} = 10 \cdot \log \frac{P_{(\mu W)}}{1000\mu W}$$

$$P_{(\mu W)} = 10^{\frac{P_{(dBm)}}{10}} \cdot 1000\mu W$$

L: P (μW) optic power in μW
 P (dBm) optic power

7 Assembly Guidelines

7.1 Assembly Guideline for FSMA connector \varnothing 2.2 mm

- Tools needed:**
- Crimp plier
 - Grinding disc LWL
 - Stripper 2.2 mm
 - Sandpaper LWL rough
 - Sandpaper LWL fine

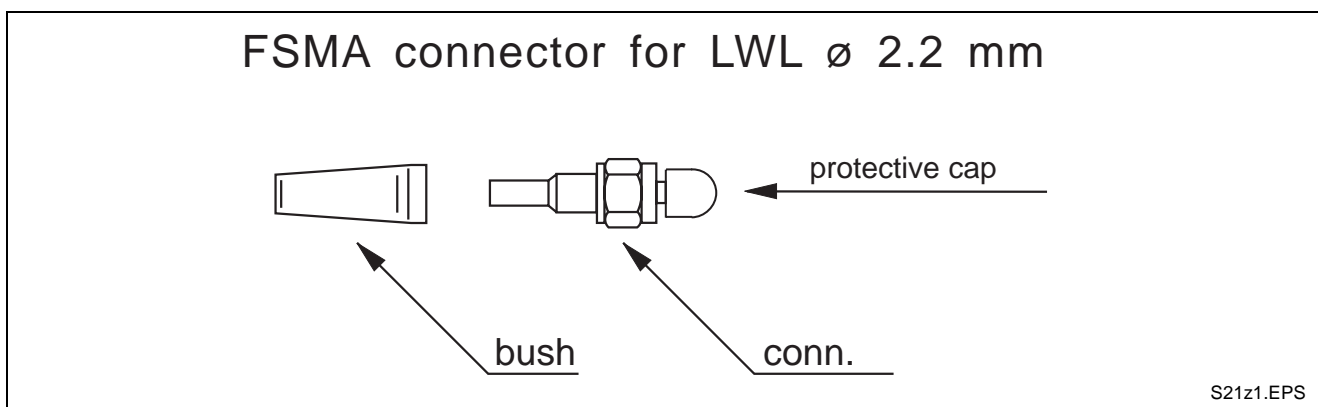

Fig. 7-1: FSMA connector for an LWL \varnothing 2.2 mm

- Preparing the LWL**
- ⇒ Unpack connector.
 - ⇒ Cut LWL to needed length.
 - ⇒ Push strap of protective cap over cable.
 - ⇒ Cut 1st stage of sleeve (at thin end) off.
 - ⇒ Push sleeve narrow end first over cable.
 - ⇒ Strip cable mantle with stripper 2.2 mm.

Note: Do not damage the LWL (\varnothing 1.0).

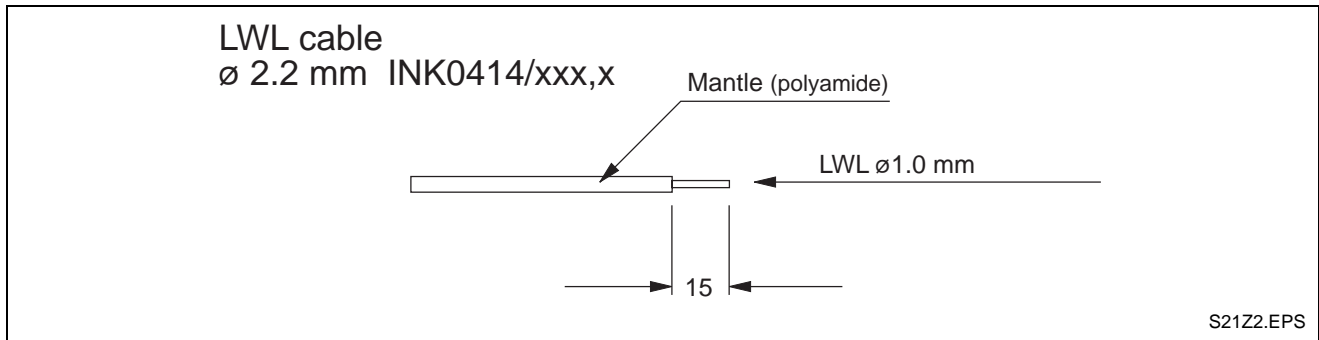

Fig. 7-2: LWL Ø 2.2 mm

Making an LWL with an FSMA connector

- ⇒ Push connector with nut onto LWL.
- ⇒ Crimp with "A" opening of crimp plier per Fig. 7-3.
- ⇒ Shorten inside strand of LWL with sharp knife or similar to length of about 1 mm.

Note: Make sure there are no breaks in the LWL.

- ⇒ Push sleeve onto FSMA connector (sleeve clicks into place, see Fig. 7-4)

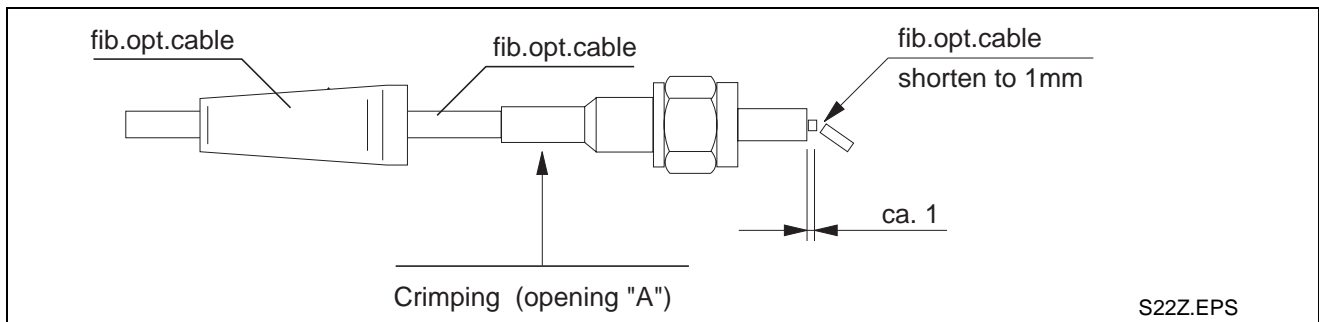

Fig. 7-3: Making an LWL with FSMA connector

- Grinding the LWL**
- ⇒ Place a sheet of sandpaper (rough) onto a flat surface, e.g., glass panel.
 - ⇒ Screw the FSMA connector completely into the LWL grinding disc.
 - ⇒ Grind the LWL to a length of about 0.5 mm. Grinding motions look like an 8.
 - ⇒ Place a sheet of sandpaper (fine) onto a flat surface, e.g., glass panel.
 - ⇒ Grind the LWL flush to the front edge of the connector. Grinding motions look like an 8.
 - ⇒ Screw FSMS connector out of LWL grinding disc.

Note: If water or conventional lubricant is used during grinding, then better attenuation values can be achieved.

- Final steps**
- ⇒ Measure attenuation and record on cable label.
 - ⇒ Glue cable label on.
 - ⇒ Place protective foil over cable label.
 - ⇒ Screw protective cap into place.

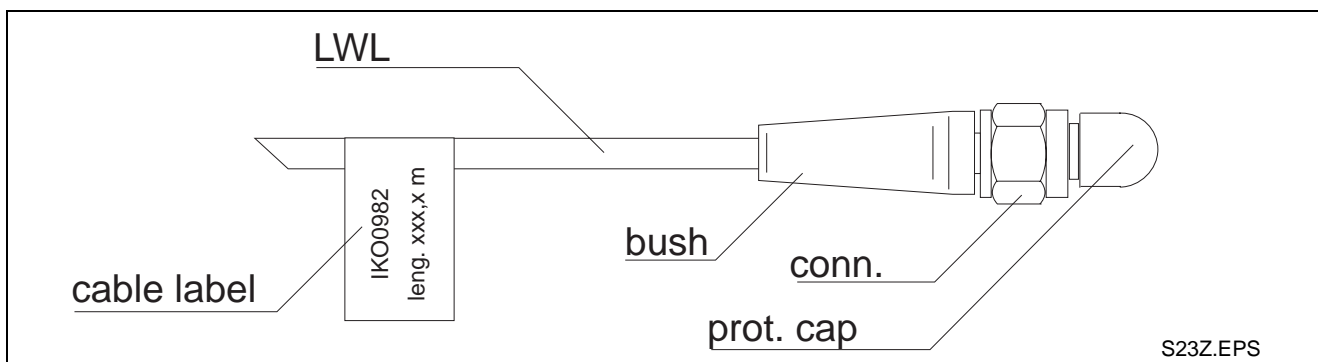

Fig. 7-4: FSMA connector 2.2 mm

7.2 Assembly Guideline for FSMA connector \varnothing 6.0 mm

- Tools needed**
- Kevlar scissors
 - Crimp plier
 - Grinding disc LWL
 - Stripping knife
 - Stripper 2.2 mm
 - Sandpaper LWL rough
 - Sandpaper LWL fine

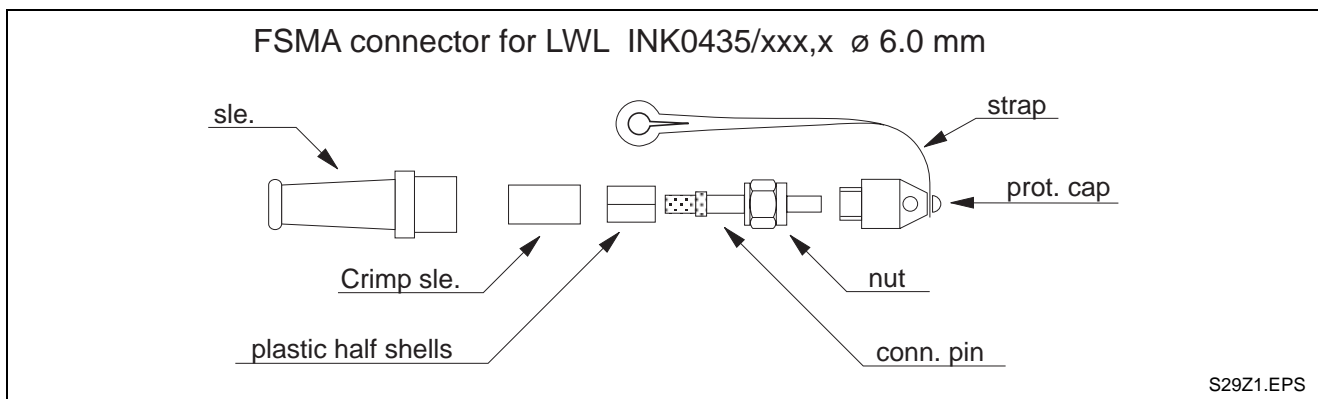

Fig. 7-5: FSMA connector for an LWL

- Preparing the LWL**
- ⇒ Cut LWL to needed length.
 - ⇒ Push sleeve onto correct side of cable.
 - ⇒ Push strap of protective cap over cable.
 - ⇒ Strip PUR ext. mantle of cable with stripping knife per Fig. 7-6.
 - ⇒ Push crimp sleeve over cable.
 - ⇒ Strip inside mantle with stripper 2.2 mm (Fig. 7-6).

Note: Avoid all breaks in the LWL (\varnothing 1.0).

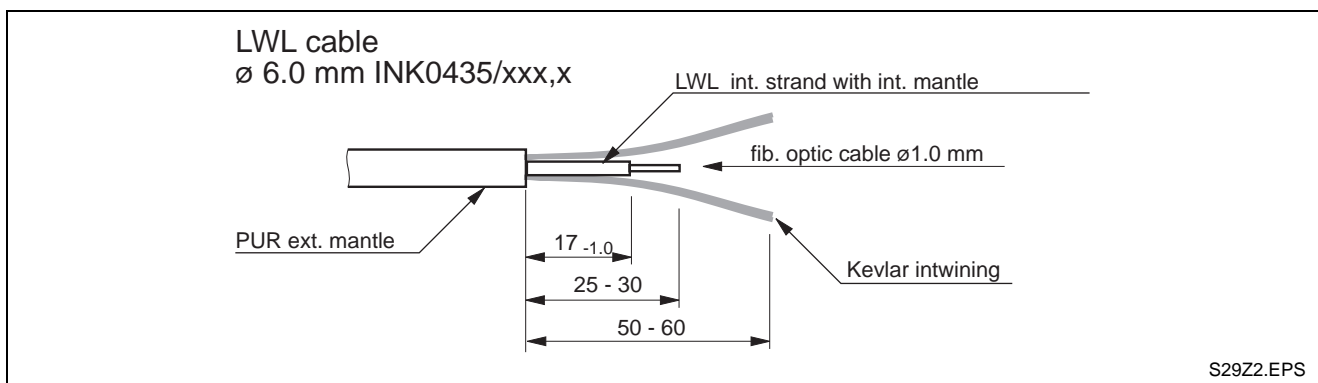

Fig. 7-6: LWL stripping information

Making an LWL with FSM connector

- ⇒ Push connector pin with nut onto cable. The knurled part of the PUR external mantle is also pressed in.
- ⇒ The inside lead crimped per Fig. 7-7 with opening „A“ of crimp pliers.

Note: Avoid all breaks in LWL.

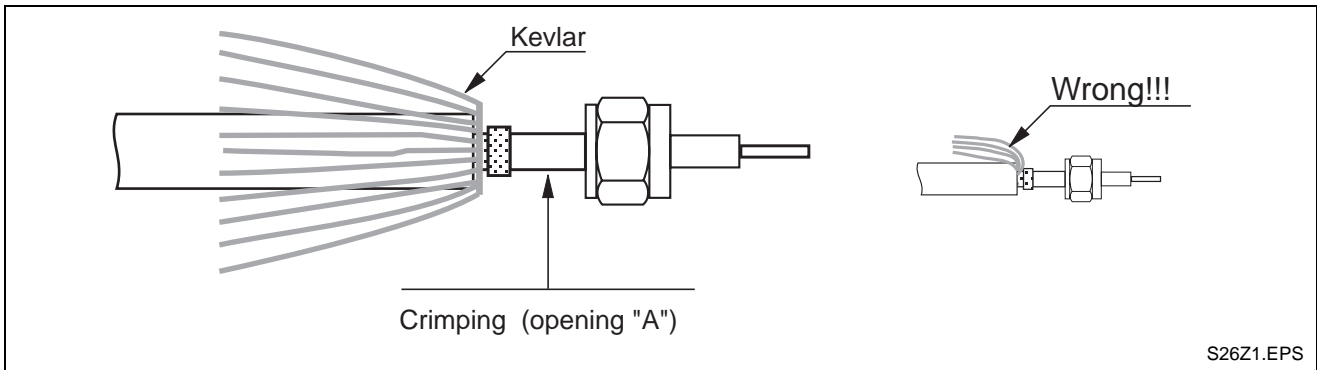

Fig. 7-7: Assembling an LWL connector

- ⇒ When pressing the FSMA connector into place the kevlar fibers could be shoved under the external mantle.
- ⇒ By pulling in connector direction, the kevlar fibers are stretched into place.

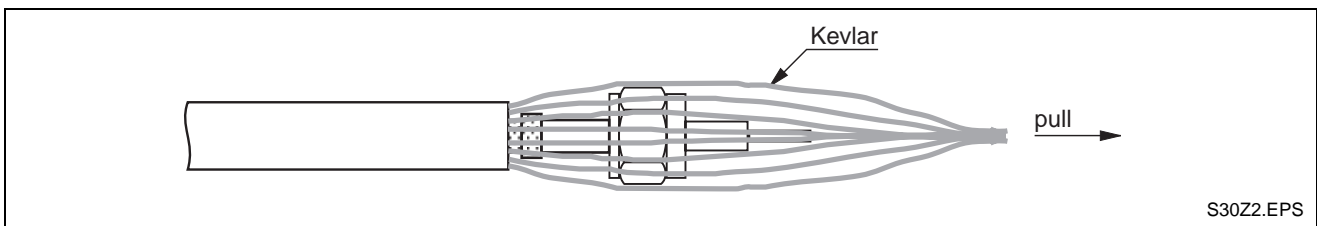

Fig. 7-8: Stretching the kevlar intwining

- ⇒ Shorten kevlar intwining with kevlar scissors to 6 – 8 mm.
- ⇒ Shorten LWL inside strands with sharp knife to length of about 1 mm.

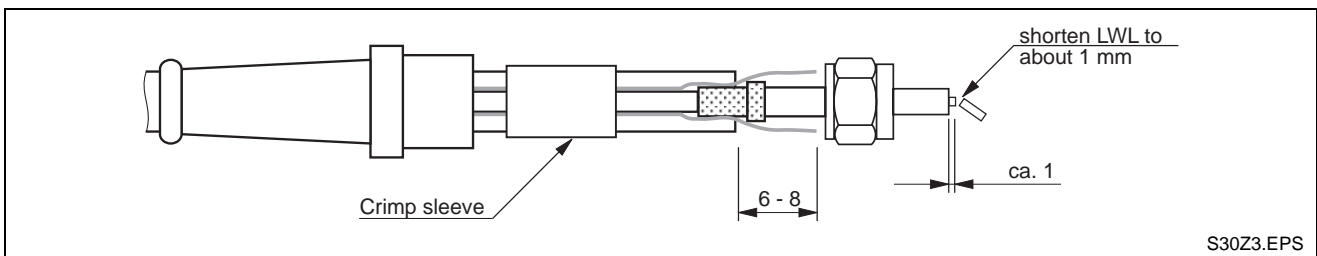

Fig. 7-9: Tension relief information

- ⇒ Place kevlar intertwining around connector pin.
- ⇒ Place plastic half shells, do not separate these, around kevlar and connector pins as shown in Fig. 7-10.
- ⇒ Push crimp sleeve up to about 0.5 mm to the nut over the half shells.
- ⇒ Crimp crimp sleeves with „B“ opening of crimp pliers.

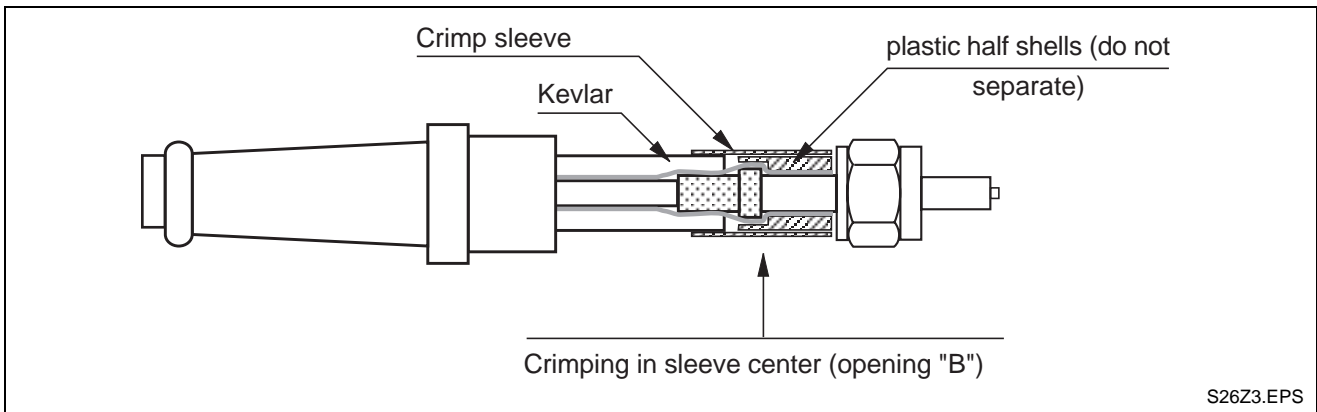

Fig. 7-10: Crimp instructions

- Grinding the LWL**
- ⇒ Place a sheet of sandpaper (rough) onto a flat surface, e.g., glass panel.
 - ⇒ Screw the FSMA connector completely into the LWL grinding disc.
 - ⇒ Grind the LWL to a length of about 0.5 mm. Grinding motions look like an 8.
 - ⇒ Place a sheet of sandpaper (fine) onto a flat surface, e.g., glass panel.
 - ⇒ Grind the LWL flush to the front edge of the connector. Grinding motions look like an 8.
 - ⇒ Screw FSMS connector out of LWL grinding disc.

Note: If water or conventional lubricant is used during grinding, then better attenuation values can be achieved.

- Final steps**
- ⇒ Push sleeve on the nut, shown in Fig. 7-7
 - ⇒ Measure attenuation and record on cable label
 - ⇒ Glue cable label on.
 - ⇒ Place protective foile over cable label.
 - ⇒ Screw protective cap into place.

Note: Do not push sleeve over nut.

The sleeve is basically, in addition to a protection against bending, also vibration protection to prevent the nut from loosening. Do not push the sleeve into place until all work on the LWL has been completed.

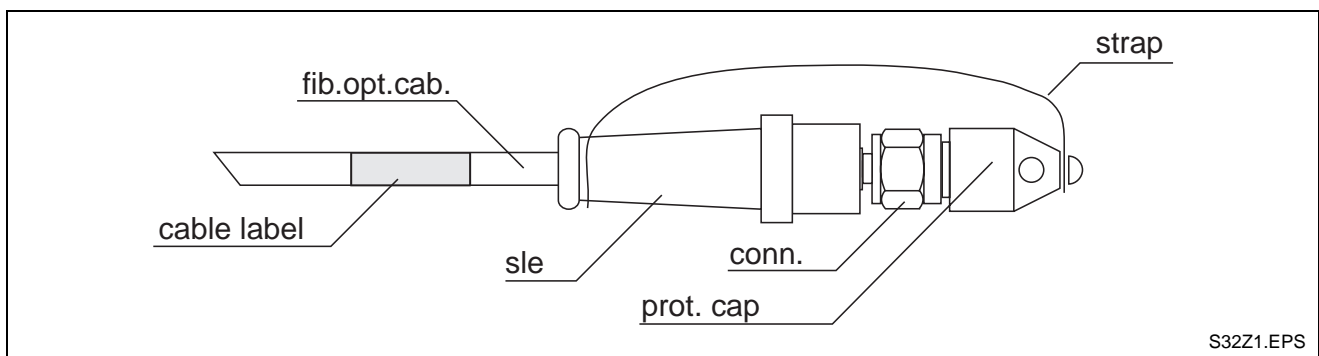

Fig. 7-11 Illustrated FSMA connector 6.0 mm

8 Tools for Assembly LWLs

8.1 Overview

Illustration	Name	Order no.	Tool for cable types INK0414 to INK0435	
			not needed	needed
	Stripping plier LWL 6.0 mm	257 321	not needed	needed
	Kevlar scissors	244 011	not needed	needed
	LWL grinding disc	244 014	needed	needed
	Crimp plier Ø 2.2 / 6.0 LWL	244 384	needed	needed
	socket wrench LWL FSMA	260 285	needed if FSMA plug-in connector not accessible	needed if FSMA plug-in connector not accessible
	stripper 2.2 mm	244 013	needed	needed
no illustration	sandpaper LWL rough	244 017	needed	needed
no illustration	sandpaper LWL fine	244 018	needed	needed

Fig. 8-1: Tools for Assembly LWLs

8.2 Test Tools for LWLs

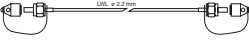

Illustration	Name	Order no.	Test tool for cable types INK0414 to INK0435	
	LWL test sender e.g., 1XT from TS- optoelectronics	not supplied by Indramat	not needed	not needed
	LWL reference measure type IKO982/1	238 523	not needed	not needed
	LWL measure coupling	252 524	not needed	not needed
no illustration	LWL level meter e.g., 4XTS from TS-Optoelectronic with adapter TSO-2000-X for FSMA	not supplied by Indramat	not needed	not needed

Fig. 8-2: Test tool for LWL cables

9 Index

A

Assembly Guideline for FSMA connector (2.2 mm 7-1
Assembly Guideline for FSMA connector (6.0 mm 7-4
Attenuation 6-2

C

Converting Optic Transmission Power 6-4

F

FSMA selection list for plug-in connectors and LWLs 3-1

I

Introduction 1-1

L

LWL accessories and leadthroughs 3-2
LWL Leadthroughs 3-2

M

Maximum Allowed Cable Attenuation 6-3
Measuring Procedure 6-2

P

Protective caps for LWL connectors or leadthroughs 3-2

R

Reference 6-2
Routing Guidelines 4-1

S

Selection List of Standard LWLs 2-1

T

Technical Data LWL – cable Ø 2.2 mm type INK0414 5-1
Technical Data LWL – cable Ø 3.0 mm type INK0436 5-3
Technical Data LWL – cable Ø 6.0 mm type INK0435 5-2
Test Tools for LWLs 8-2

10 Kundenbetreuungsstellen - Sales & Service Facilities

Kundenbetreuungsstellen - Sales & Service Facilities

Deutschland - Germany

Vertriebsgebiet Mitte Germany Centre <input checked="" type="checkbox"/> V/S <input checked="" type="checkbox"/> Service	Vertriebsgebiet Ost Germany East <input checked="" type="checkbox"/> V/S <input checked="" type="checkbox"/> Service	Vertriebsgebiet West Germany West <input checked="" type="checkbox"/> V/S <input checked="" type="checkbox"/> Service	Vertriebsgebiet Nord Germany North <input checked="" type="checkbox"/> V/S <input type="checkbox"/> Service
INDRAMAT GmbH Bgm.-Dr.-Nebel-Str. 2 D - 97816 Lohr am Main Telefon: +49 (0)9352/40-0 Telefax: +49 (0)9352/40-4885	INDRAMAT GmbH Beckerstraße 31 D - 09120 Chemnitz Telefon: +49 (0)371/35 55-0 Telefax: +49 (0)371/35 55-333	INDRAMAT GmbH Harkortstraße 25 D - 40849 Ratingen Telefon: +49 (0)2102/43 18-0 Telefax: +49 (0)2102/41 315	INDRAMAT GmbH Kieler Straße 212 D - 22525 Hamburg Telefon: +49 (0)40/85 31 57-0 Telefax: +49 (0)40/85 31 57-15
Vertriebsgebiet Süd Germany South <input checked="" type="checkbox"/> V/S <input type="checkbox"/> Service	Gebiet Südwest Germany South-West <input checked="" type="checkbox"/> V/S <input checked="" type="checkbox"/> Service		INDRAMAT Service-Hotline INDRAMAT GmbH Telefon: +49 (0)172/660 04 06 oder Telefon: +49 (0)171/333 88 26
INDRAMAT GmbH Ridlerstraße 75 D-80339 München Telefon: +49 (0)89/540138-30 Telefax: +49 (0)89/540138-10	INDRAMAT GmbH Böblinger Straße 25 D-71229 Leonberg Telefon: +49 (0)7152/9 72-6 Telefax: +49 (0)7152/9 72-727		

Kundenbetreuungsstellen in Deutschland - Service agencies in Germany

Europa - Europe

<p>Austria <input checked="" type="checkbox"/> V/S <input type="checkbox"/> Service</p> <p>Mannesmann Rexroth Ges.m.b.H. Geschäftsbereich INDRAMAT Hägelingasse 3 A - 1140 Wien</p> <p>Telefon: +43 (0)1/9852540-400 Telefax: +43 (0)1/9852540-93</p>	<p>Austria <input type="checkbox"/> V/S <input checked="" type="checkbox"/> Service</p> <p>Mannesmann Rexroth G.m.b.H. Geschäftsbereich INDRAMAT Industriepark 18 A - 4061 Pasching</p> <p>Telefon: +43 (0)7221/605-0 Telefax: +43 (0)7221/605-21</p>	<p>Belgium <input checked="" type="checkbox"/> V/S <input checked="" type="checkbox"/> Service</p> <p>Mannesmann Rexroth N.V.-S.A. Geschäftsbereich INDRAMAT Industrielaan 8 B-1740 Ternat</p> <p>Telefon: +32 (0)2/5823180 Telefax: +32 (0)2/5824310</p>	<p>Denmark <input checked="" type="checkbox"/> V/S <input checked="" type="checkbox"/> Service</p> <p>BEC AS Zinkvej 6 DK-8900 Randers</p> <p>Telefon: +45 (0)87/11 90 60 Telefax: +45 (0)87/11 90 61</p>
<p>England <input checked="" type="checkbox"/> V/S <input checked="" type="checkbox"/> Service</p> <p>Mannesmann Rexroth Ltd. INDRAMAT Division 4 Esland Place, Love Lane GB - Cirencester, Glos GL7 1YG</p> <p>Telefon: +44 (0)1285/658671 Telefax: +44 (0)1285/654991</p>	<p>Finland <input checked="" type="checkbox"/> V/S <input type="checkbox"/> Service</p> <p>Rexroth Mecman OY Ansatie 6 SF-017 40 Vantaa</p> <p>Telefon: +358 (0)9/84 91 11 Telefax: +358 (0)9/84 91 13 60</p>	<p>France <input checked="" type="checkbox"/> V/S <input checked="" type="checkbox"/> Service</p> <p>Mannesmann Rexroth S.A. Division INDRAMAT Parc des Barbanniers 4, Place du Village F-92632 Gennevilliers Cedex</p> <p>Telefon: +33 (0)141 47 54 30 Telefax: +33 (0)147 94 69 41 Hotline: +33 (0)6 08 33 43 28</p>	<p>France <input checked="" type="checkbox"/> V/S <input type="checkbox"/> Service</p> <p>Mannesmann Rexroth S.A. Division INDRAMAT 270, Avenue de Lardenne F - 31100 Toulouse</p> <p>Telefon: +33 (0)5 61 49 95 19 Telefax: +33 (0)5 61 31 00 41</p>
<p>France <input checked="" type="checkbox"/> V/S <input type="checkbox"/> Service</p> <p>Mannesmann Rexroth S.A. Division INDRAMAT 91, Bd. Irène Joliot-Curie F - 69634 Vénissieux - Cedex</p> <p>Telefon: +33 (0)4 78 78 53 65 Telefax: +33 (0)4 78 78 52 53</p>	<p>Italy <input checked="" type="checkbox"/> V/S <input checked="" type="checkbox"/> Service</p> <p>Mannesmann Rexroth S.p.A. Divisione INDRAMAT Via G. Di Vittoria, 1 I - 20063 Cernusco S/N.MI</p> <p>Telefon: +39 (0)2/92 36 52 70 Telefax: +39 (0)2/92 36 55 12</p>	<p>Italy <input checked="" type="checkbox"/> V/S <input checked="" type="checkbox"/> Service</p> <p>Mannesmann Rexroth S.p.A. Divisione INDRAMAT Via Borgomanero, 11 I - 10145 Torino</p> <p>Telefon: +39 (0)11/7 71 22 30 Telefax: +39 (0)11/7 71 01 90</p>	<p>Italy <input checked="" type="checkbox"/> V/S <input type="checkbox"/> Service</p> <p>Mannesmann Rexroth S.p.A. Divisione INDRAMAT Via del Progresso, 16 (Zona Ind.) I - 35020 Padova</p> <p>Telefon: +39 (0)49/8 70 13 70 Telefax: +39 (0)49/8 70 13 77</p>
<p>Italy <input type="checkbox"/> V/S <input checked="" type="checkbox"/> Service</p> <p>Mannesmann Rexroth S.p.A. Divisione INDRAMAT Via de Nicola, 12 I - 80053 Castellammare di Stabia NA</p> <p>Telefon: +39 (0)81/8 72 30 37 Telefax: +39 (0)81/8 72 30 18</p>	<p>Italy <input checked="" type="checkbox"/> V/S <input type="checkbox"/> Service</p> <p>Mannesmann Rexroth S.p.A. Divisione INDRAMAT Viale Oriani, 38/A I - 40137 Bologna</p> <p>Telefon: +39 (0)51/34 14 14 Telefax: +39 (0)51/34 14 22</p>	<p>Netherlands <input checked="" type="checkbox"/> V/S <input type="checkbox"/> Service</p> <p>Hydraudyne Hydrauliek B.V. Kruisbroeksestraat 1 P.O. Box 32 NL - 5281 RV Boxtel</p> <p>Telefon: +31 (0)411/65 19 51 Telefax: +31 (0)411/65 14 83</p>	<p>Netherlands <input type="checkbox"/> V/S <input checked="" type="checkbox"/> Service</p> <p>Hydrocare B.V. Kruisbroeksestraat 1 P.O. Box 32 NL - 5281 RV Boxtel</p> <p>Telefon: +31 (0)411/65 19 51 Telefax: +31 (0)411/67 78 14</p>
<p>Spain <input checked="" type="checkbox"/> V/S <input checked="" type="checkbox"/> Service</p> <p>Mannesmann Rexroth S.A. Division INDRAMAT Centro Industrial Santiga Obradors s/n E-08130 Santa Perpetua de Mogoda Barcelona</p> <p>Telefon: +34 937 47 94 00 Telefax: +34 937 47 94 01</p>	<p>Spain <input checked="" type="checkbox"/> V/S <input checked="" type="checkbox"/> Service</p> <p>Goimendi S.A. División Indramat Jolastokieta (Herrera) Apartado 11 37 E - 20017 San Sebastian</p> <p>Telefon: +34 9 43/40 01 63 Telefax: +34 9 43/39 17 99</p>	<p>Sweden <input checked="" type="checkbox"/> V/S <input checked="" type="checkbox"/> Service</p> <p>Rexroth Mecman Svenska AB INDRAMAT Division Varuvägen 7 S - 125 81 Stockholm</p> <p>Telefon: +46 (0)8/727 92 00 Telefax: +46 (0)8/64 73 277</p>	<p>Switzerland - East <input checked="" type="checkbox"/> V/S <input checked="" type="checkbox"/> Service</p> <p>Mannesmann Rexroth AG Geschäftsbereich INDRAMAT Gewerbstraße 3 CH-8500 Frauenfeld</p> <p>Telefon: +41 (0)52/720 21 00 Telefax: +41 (0)52/720 21 11</p>
<p>Switzerland - West <input checked="" type="checkbox"/> V/S <input type="checkbox"/> Service</p> <p>Mannesmann Rexroth SA Département INDRAMAT Chemin de l'Ecole 6 CH-1036 Sullens</p> <p>Telefon: +41 (0)21/731 43 77 Telefax: +41 (0)21/731 46 78</p>	<p>Russia <input type="checkbox"/> V/S <input checked="" type="checkbox"/> Service</p> <p>Tschudnenko E.B. Arsenia 22 RUS - 153000 Ivanovo Rußland</p> <p>Telefon: +7 093/223 96 33 oder/or +7 093/223 95 48 Telefax: +7 093/223 46 01</p>	<p>Slovenia <input checked="" type="checkbox"/> V/S <input checked="" type="checkbox"/> Service</p> <p>DOMEL Elektromotorji in gospodinjiski aparati d. d. Otoki 21 SLO - 64 228 Zelezniki</p> <p>Telefon: +386 64/61 73 32 Telefax: +386 64/64 71 50</p>	<p>Turkey <input checked="" type="checkbox"/> V/S <input checked="" type="checkbox"/> Service</p> <p>Mannesmann Rexroth Hidropar A..S. Fevzi Cakmak Cad No. 3 TR - 34630 Sefaköy Istanbul</p> <p>Telefon: +90 212/541 60 70 Telefax: +90 212/599 34 07</p>

Europäische Kundenbetreuungsstellen (ohne Deutschland)
European Service agencies (without Germany)

Außerhalb Europa - outside Europe

Argentina <input checked="" type="checkbox"/> V/S <input type="checkbox"/> Service Mannesmann Rexroth S.A.I.C. Division INDRAMAT Acassusso 48 41/7 RA - 1605 Munro (Buenos Aires) Telefon: +54 (0)1/756 01 40 +54 (0)1/756 01 36	Argentina <input type="checkbox"/> V/S <input checked="" type="checkbox"/> Service NAKASE Asesoramiento Tecnico Calle 49, No. 5764-66 RA - 1653 Villa Balester Provincia de Buenos Aires Telefon: +54 (0) 1/768 24 13 Telefax: +54 (0) 1/768 36 43	Australia <input checked="" type="checkbox"/> V/S <input checked="" type="checkbox"/> Service AIMS - Australian Industrial Machinery Services Pty. Ltd. Unit 3/45 Horne ST Campbellfield 3061 AUS - Melbourne, VIC Telefon: +61 (0)3/93 59 02 28 Telefax: +61 (0)3/93 59 02 86	Brazil <input checked="" type="checkbox"/> V/S <input checked="" type="checkbox"/> Service Mannesmann Rexroth Automação Ltda. Divisão INDRAMAT Rua Georg Rexroth, 609 Vila Padre Anchieta BR - 09951-270 Diadema-SP [Caixa Postal 377] [BR-09901-970 Diadema-SP] Telefon: +55 (0)11/745 90 60 +55 (0)11/745 90 70 Telefax: +55 (0)11/745 90 50
	Canada <input checked="" type="checkbox"/> V/S <input checked="" type="checkbox"/> Service Basic Technologies Corporation Burlington Division 3426 Mainway Drive Burlington, Ontario Canada L7M 1A8 Telefon: +1 905/335 55 11 Telefax: +1 905/335-41 84	China <input checked="" type="checkbox"/> V/S <input type="checkbox"/> Service Mannesmann Rexroth (China) Ltd. Shanghai Office - Room 206 Shanghai Internat. Trade Centre 2200 Yanan Xi Lu PRC - Shanghai 200335 Telefon: +86 21/62 75 53 33 Telefax: +86 21/62 75 56 66	China <input type="checkbox"/> V/S <input checked="" type="checkbox"/> Service Mannesmann Rexroth (China) Ltd. Shanghai Parts & Service Center 199 Wu Cao Road, Hua Cao Minhang District PRC - Shanghai 201 103 Telefon: +86 21/62 20 00 58 Telefax: +86 21/62 20 00 68
China <input checked="" type="checkbox"/> V/S <input type="checkbox"/> Service Mannesmann Rexroth (China) Ltd. 15/F China World Trade Center 1, Jianguomenwai Avenue PRC - Beijing 100004 Telefon: +86 10/65 05 03 80 Telefax: +86 10/65 05 03 79	China <input checked="" type="checkbox"/> V/S <input type="checkbox"/> Service Mannesmann Rexroth (China) Ltd. A-5F., 123 Lian Shan Street Sha He Kou District PRC - Dalian 116 023 Telefon: +86 411/46 78 930 Telefax: +86 411/46 78 932	Hongkong <input checked="" type="checkbox"/> V/S <input checked="" type="checkbox"/> Service Rexroth (China) Ltd. 19 Cheung Shun Street 1st Floor, Cheung Sha Wan, Kowloon, Hongkong Telefon: +852 27/41 13 51/-54 oder/or +852 27/41 14 30 Telefax: +852 27/86 07 33	India <input checked="" type="checkbox"/> V/S <input checked="" type="checkbox"/> Service Mannesmann Rexroth (India) Ltd. INDRAMAT Division Plot. 96, Phase III Peenya Industrial Area IND - Bangalore - 560058 Telefon: +91 (0)80/8 39 21 01 Telefax: +91 (0)80/8 39 43 45
India <input checked="" type="checkbox"/> V/S <input checked="" type="checkbox"/> Service Mannesmann Rexroth (India) Ltd. INDRAMAT Division Plot. A-58, TTC Industrial Area Thane Turbhe Midc Road Mahape Village IND - Navi Mumbai - 400 701 Telefon: +91 (0)22/7 61 46 22 Telefax: +91 (0)22/7 68 15 31	Indonesia <input checked="" type="checkbox"/> V/S <input type="checkbox"/> Service PT. Rexroth Wijayakusuma Jl. Raya Bekasi Km 21 Pulogadung RI - Jakarta Timur 13920 Telefon: +62 21/4 61 04 87 +62 21/4 61 04 88 Telefax: +62 21/4 60 01 52	Japan <input checked="" type="checkbox"/> V/S <input checked="" type="checkbox"/> Service Rexroth Automation Co., Ltd. INDRAMAT Division 1F, I.R. Building Nakamachidai 4-26-44 Tsuzuki-ku, Yokohama-shi J - Kanagawa-ken 224-004 Telefon: +81 459/42-72 10 Telefax: +81 459/42-03 41	Mexico <input checked="" type="checkbox"/> V/S <input type="checkbox"/> Service Rexroth Mexico S.A. de C.V. Calle Neptuno 72 Unidad Ind. Vallejo MEX - 07700 Mexico, D.F. Telefon: +52 5 754 17 11 +52 5 754 36 84 +52 5 754 12 60 Telefax: +52 5 754 50 73 +52 5 752 59 43
Korea <input checked="" type="checkbox"/> V/S <input checked="" type="checkbox"/> Service Mannesmann Rexroth-Seki Co Ltd. 1500-12 Da-Dae-Dong ROK - Saha-Ku, Pusan, 604-050 Telefon: +82 (0)51/2 60 06 18 Telefax: +82 (0)51/2 60 06 19	Korea <input checked="" type="checkbox"/> V/S <input checked="" type="checkbox"/> Service Seo Chang Corporation Ltd. Room 903, Jeail Building 44-35 Yeouido-Dong Yeoungdeungpo-Ku C.P.O.Box 97 56 ROK - Seoul Telefon: +82 (0)2/7 80 82 08 +82 (0)2/7 80 82 09 Telefax: +82 (0)2/7 84 54 08	South Africa <input checked="" type="checkbox"/> V/S <input checked="" type="checkbox"/> Service HYTEC Automation (Pty) Ltd. 28 Banfield Road, Industria North RSA - Maraisburg 1700 Telefon: +27 (0)11/673 20 80 Telefax: +27 (0)11/673 72 69	Taiwan <input checked="" type="checkbox"/> V/S <input type="checkbox"/> Service Rexroth Uchida Co., Ltd. No.1, Tsu Chiang Street Tu Cheng Ind. Estate Taipei Hsien, Taiwan, R.O.C. Telefon: +886 2/2 68 13 47 Telefax: +886 2/2 68 53 88

Kundenbetreuungsstellen außerhalb Europa - Service agencies outside Europe

Außerhalb Europa / USA - outside Europe / USA

<p>USA <input checked="" type="checkbox"/> V/S <input checked="" type="checkbox"/> Service</p> <p>Mannesmann Rexroth Corporation INDRAMAT Division 5150 Prairie Stone Parkway USA - Hoffman Estates, IL 60192-3707</p> <p>Telefon: +1 847/6 45 36 00 Telefax: +1 847/6 45 62 01</p>	<p>USA <input checked="" type="checkbox"/> V/S <input checked="" type="checkbox"/> Service</p> <p>Mannesmann Rexroth Corporation INDRAMAT Division Central Region Technical Center USA - Auburn Hills, MI 48326</p> <p>Telefon: +1 248/3 93 33 30 Telefax: +1 248/3 93 29 06</p>	<p>USA <input checked="" type="checkbox"/> V/S <input checked="" type="checkbox"/> Service</p> <p>Mannesmann Rexroth Corporation INDRAMAT Division Southeastern Technical Center 3625 Swiftwater Park Drive USA - Suwanee Georgia 30174</p> <p>Telefon: +1 770/9 32 32 00 +1 770/9 32 19 03</p>	<p>USA <input checked="" type="checkbox"/> V/S <input checked="" type="checkbox"/> Service</p> <p>Mannesmann Rexroth Corporation INDRAMAT Division Northeastern Technical Center 99 Rainbow Road USA - East Granby, Connecticut 06026</p> <p>Telefon: +1 860/8 44 83 77 +1 860/8 44 85 95</p>
<p>USA <input checked="" type="checkbox"/> V/S <input checked="" type="checkbox"/> Service</p> <p>Mannesmann Rexroth Corporation INDRAMAT Division Charlotte Regional Sales Office 14001 South Lakes Drive USA - Charlotte, North Carolina 28273</p> <p>Telefon: +1 704/5 83 97 62 +1 704/5 83 14 86</p>			

Kundenbetreuungsstellen außerhalb Europa / USA
 Service agencies outside Europe / USA

Bosch Rexroth AG
Electric Drives and Controls
P.O. Box 13 57
97803 Lohr, Germany
Bgm.-Dr.-Nebel-Str. 2
97816 Lohr, Germany
Phone +49 (0)93 52-40-50 60
Fax +49 (0)93 52-40-49 41
service.svc@boschrexroth.de
www.boschrexroth.com



R911284755