

Rexroth Machine Operator Panel VDP 92.1

R911320191
Edition 02

Project Planning Manual

Rexroth
satisloh

\$1
Kanal1

Automatik
Folgesatz

ON
bereit

Rexroth
MTX

18.03.2004 | 12:34:39

Bereit für NC-Start

| W | | | | Sollposition | Endposition | Restweg |
|-----------|---|----|---|----------------|----------------|--------------|
| X | ↓ | mm | | 129.990 | 129.990 | 0.000 |
| Z | ↓ | mm | | 300.003 | 300.003 | 0.000 |
| Z2 | ↓ | mm | | 0.998 | 0.998 | 0.000 |
| C | ⊗ | s | o | 0.000 | 0.000 | 0.000 |
| C2 | ⊗ | s | o | 0.000 | 0.000 | 0.000 |
| T | s | o | | 0.000 | 1.034 | 0.000 |

| F | W | Programm | Sollwert | Istwert | Override | Max | Getr.ST. |
|----|---|----------|----------|---------|----------|-----|----------|
| S1 | ⊗ | 1/min | 100.0 | 45.0 | -0.5 | 45% | 120% |
| S3 | ⊗ | 1/min | 0.0 | 0.0 | 0.2 | 45% | 120% |

/mnt/Test/Test SD lesen.app ?

| | | | | |
|--|-----|-----|-----|-----|
| | G01 | G18 | G90 | G95 |
| 1 @1=200 | G09 | G61 | G40 | G68 |
| 1 OPENW(2,"Protokoll.txt",1024,"Lesen SD 12x - Spindelz... | G65 | G71 | | G66 |

2 REWRITE(2)

WAIT

S1=100 M103

| | | |
|-------|----------|----------|
| | NPV | G53.1 |
| aktiv | akt.Sch. | D-Nummer |
| | 2 | 0 |

Programm Anwahl
F2 aktives NC-Programm
F3
F4 Nullpunkt-Verschiebung
F5 aktive D-Korrekturen
F6 SPL-Verstellen
F7 >>
F8
F9

Planen
Maschine
Programm
Werkzeugverwaltung
Wartung
Inbetriebn.
Kanaldialog
Diagnose

| | |
|---------------------------------|---|
| Title | Rexroth Maschine Operator Panel VDP 92.1 |
| Type of Documentation | Project Planning Manual |
| Document Typecode | DOK-SUPPL*-VDP*92.1***-PR02-EN-P |
| Internal File Reference | Document Number, 120-2100-B387-02/EN |
| Purpose of Documentation | This documentation describes the machine operator panel VDP 92.1. |

Record of Revisions

| Description | Release Date | Notes |
|---------------------|--------------|-----------------------|
| 120-2100-B387-02/EN | 05/07 | First English Edition |
| | | |
| | | |

Copyright © 2007 Bosch Rexroth AG

Copying this document, giving it to others and the use or communication of the contents thereof without express authority, are forbidden. Offenders are liable for the payment of damages. All rights are reserved in the event of the grant of a patent or the registration of a utility model or design (DIN 34-1).

Validity The specified data is for product description purposes only and may not be deemed to be guaranteed unless expressly confirmed in the contract. All rights are reserved with respect to the content of this documentation and the availability of the product.

Published by Bosch Rexroth AG
 Bgm.-Dr.-Nebel-Str. 2 • D-97816 Lohr a. Main
 Telephone +49 (0)93 52/40-0 • Tx 68 94 21 • Fax +49 (0)93 52/40-48 85
<http://www.boschrexroth.com/>
 Dept. BRC/EPY (NH)

Note This document has been printed on chlorine-free bleached paper.

Contents

| | | |
|----------|--|------------|
| 1 | System Presentation | 1-1 |
| 1.1 | Brief Description | 1-1 |
| 1.2 | Display | 1-1 |
| 1.3 | Operating Elements | 1-1 |
| 1.4 | Using the Machine Operator Panel with Display in Residential Areas | 1-1 |
| 1.5 | Commissioning | 1-1 |
| 2 | Important Directions for Use | 2-1 |
| 2.1 | Appropriate Use | 2-1 |
| | Introduction | 2-1 |
| | Areas of Use and Application | 2-2 |
| 2.2 | Inappropriate Use | 2-2 |
| 3 | Safety Instructions for Electric Drives and Controls | 3-1 |
| 3.1 | Introduction | 3-1 |
| 3.2 | Explanations | 3-1 |
| 3.3 | Hazards by Improper Use | 3-2 |
| 3.4 | General Information | 3-3 |
| 3.5 | Protection Against Contact with Electrical Parts | 3-4 |
| 3.6 | Protection Against Electric Shock by Protective Low Voltage (PELV) | 3-5 |
| 3.7 | Protection Against Dangerous Movements | 3-6 |
| 3.8 | Protection Against Magnetic and Electromagnetic Fields During Operation and Mounting | 3-7 |
| 3.9 | Protection Against Contact with Hot Parts | 3-8 |
| 3.10 | Protection During Handling and Mounting | 3-8 |
| 3.11 | Battery Safety | 3-9 |
| 3.12 | Protection Against Pressurized Systems | 3-9 |
| 4 | Technical Data | 4-1 |
| 4.1 | Front Panel | 4-1 |
| 4.2 | Power Supply | 4-1 |
| 4.3 | Ambient Conditions | 4-1 |
| 4.4 | Used Standards | 4-2 |
| 4.5 | Wear Parts | 4-3 |
| 4.6 | Compatibility Test | 4-3 |

| | | |
|----------|--|------------|
| 5 | Dimensions | 5-1 |
| 5.1 | Housing Dimensions..... | 5-1 |
| | Housing Dimensions of the VDP 92.1, Front and Side View | 5-1 |
| | Housing Dimensions of the VDP 92.1, Rear and Side View | 5-2 |
| 5.2 | Installation..... | 5-3 |
| | Installation Notes | 5-3 |
| | Mounting Cut-Out | 5-3 |
| 6 | Interfaces | 6-1 |
| 6.1 | View on the Connector Panel | 6-1 |
| 6.2 | Description of the Interfaces..... | 6-1 |
| 6.3 | 24 VDC Power Supply | 6-2 |
| 6.4 | USB Interfaces..... | 6-3 |
| 6.5 | G4 Display Interface | 6-4 |
| 6.6 | Combined Keyboard/Mouse Interface | 6-4 |
| 6.7 | Mouse Interface | 6-5 |
| 6.8 | Connector Panel of the Profibus Interface..... | 6-6 |
| 6.9 | Protective Earth Terminal | 6-6 |
| 6.10 | Current and Voltage Supply (X1S1) | 6-6 |
| 6.11 | Field Bus Interface PROFIBUS DP (X7P1)..... | 6-7 |
| | General Information | 6-7 |
| | Pin Assignment..... | 6-7 |
| 6.12 | Digital 24 V Inputs and Outputs (X2I1, X2I2, X2O1) | 6-8 |
| | Pin Assignment (3 x 8-Pin Weidmüller Connector, 3.5 pin spacing)..... | 6-8 |
| | Characteristics of Digital Inputs | 6-8 |
| | Characteristics of Digital Outputs | 6-9 |
| 6.13 | Key Switches, Machine On/Off, Emergency Stop (X2M1) | 6-9 |
| | Pin Assignment X2M1 (12-Pin Weidmüller Connector, 3.5 pin spacing) | 6-9 |
| 6.14 | Connection for External Hand-held Terminal (X81) | 6-10 |
| | Pin Assignment (25-Pin Female Connector Strip D-SUB) | 6-10 |
| 6.15 | Connection for Internal Handwheel (X82) | 6-11 |
| | Pin Assignment (6-Pin Weidmüller Connector, 3.5 Pin Spacing)..... | 6-11 |
| 7 | Commissioning | 7-1 |
| 7.1 | GSD File | 7-1 |
| 7.2 | PROFIBUS DP Address Settings | 7-1 |
| 7.3 | Baud Rate Setting..... | 7-1 |
| 7.4 | Status Displays | 7-2 |
| | System Stop | 7-3 |
| 7.5 | Pin Assignment – Digital 24 V Inputs and Outputs..... | 7-4 |
| | PROFIBUS DP Module (GSD File) | 7-4 |
| 7.6 | External Hand-Held Terminal | 7-4 |
| | PROFIBUS DP Module (GSD File) | 7-4 |
| 7.7 | Internal Handwheel..... | 7-4 |
| | PROFIBUS DP Module (GSD File) | 7-4 |

| | | |
|-----------|--|-------------|
| 8 | Disposal and Environmental Protection | 8-1 |
| 8.1 | Disposal | 8-1 |
| | Products | 8-1 |
| | Packaging Materials | 8-1 |
| 8.2 | Environmental Protection..... | 8-1 |
| | No Release of Hazardous Substances | 8-1 |
| | Materials Contained in the Products | 8-1 |
| | Recycling | 8-2 |
| 9 | List of Figures | 9-1 |
| 10 | Service and Support | 10-1 |
| 10.1 | Helpdesk..... | 10-1 |
| 10.2 | Service Hotline..... | 10-1 |
| 10.3 | Internet..... | 10-1 |
| 10.4 | Helpful Information..... | 10-1 |

1 System Presentation

1.1 Brief Description

The machine operator panel VDP 92.1 is a compact combination consisting of a TFT display and operating elements for the manual machine operation.

The VDP 92.1 is a customer-specific development.

1.2 Display

The display of the VDP 92.1 can be connected with the industrial PCs of Rexroth like the IndraControl VSB 40 or the IndraControl VPB 40 via a G4 display interface.

1.3 Operating Elements

The operating elements of the VDP 92.1 serve to operate the machines manually. They provide an emergency stop pushbutton, USB connection, key switch, feed override or handwheel functionality (depending on the position of the key switch) and pushbuttons.

1.4 Using the Machine Operator Panel with Display in Residential Areas

VDP 92.1-type installations that are used in residential areas (housing, business and commercial areas as well as small-sized enterprises) require a single approval by an authority or a testing agency. In Germany, such single approvals are issued by the "Regulierungsbehörde für Telekommunikation und Post (RegTP)" (German Regulatory Authority for Telecommunications and Posts).

1.5 Commissioning

Mount the VDP 92.1 properly (for this, see chapter 5.2, "Installation", on page 5-3). Then, connect the device to the power supply and, if required, to the network.

2 Important Directions for Use

2.1 Appropriate Use

Introduction

Rexroth products represent state-of-the-art developments and manufacturing. They are tested prior to delivery to ensure operating safety and reliability.

The products may only be used in the manner that is defined as appropriate. If they are used in an inappropriate manner, then situations can develop that may lead to property damage or injury to personnel.

Note: Bosch Rexroth, as manufacturer, is not liable for any damages resulting from inappropriate use. In such cases, the guarantee and the right to payment of damages resulting from inappropriate use are forfeited. The user alone carries all responsibility of the risks.

Before using Rexroth products, make sure that all the pre-requisites for appropriate use of the products are satisfied:

- Personnel that in any way, shape or form uses our products must first read and understand the relevant safety instructions and be familiar with appropriate use.
- If the product takes the form of hardware, then they must remain in their original state, in other words, no structural changes are permitted. It is not permitted to decompile software products or alter source codes.
- Do not mount damaged or faulty products or use them in operation.
- Make sure that the products have been installed in the manner described in the relevant documentation.

Areas of Use and Application

The VDP 92.1 of Rexroth is a machine operator panel, that represents in combination with an industrial PC like the IndraControl VSB 40 or the IndraControl VPB 40 a PC-based operator terminal. Thus, the VDP 92.1 can – depending on the application or configuration – also perform control functions.

Note: The VDP 92.1 may only be used with the accessories and parts specified in this document. If a component has not been specifically named, then it may not be either mounted or connected. The same applies to cables and lines.

Operation is only permitted in the specified configurations and combinations of components using the software and firmware as specified in the relevant function descriptions.

Typical areas of application of the VDP 92.1 are grinding and milling machines:

The VDP 92.1 may only be operated under the assembly, installation and ambient conditions as described here (temperature, system of protection, humidity, EMC requirements, etc.) and in the position specified.

2.2 Inappropriate Use

Using the VDP 92.1 outside of the above-referenced areas of application or under operating conditions other than described in the document and the technical data specified is defined as "inappropriate use".

The VDP 92.1 may not be used, if

- it is subject to operating conditions that do not meet the above specified ambient conditions. This includes, for example, operation under water, in the case of extreme temperature fluctuations or extremely high maximum temperatures, or if
- Bosch Rexroth has not specifically released them for that intended purpose. Please note the specifications outlined in the general Safety Guidelines!

3 Safety Instructions for Electric Drives and Controls

3.1 Introduction

Read these instructions before the initial startup of the equipment in order to eliminate the risk of bodily harm or material damage. Follow these safety instructions at all times.

Do not attempt to install or start up this equipment without first reading all documentation provided with the product. Read and understand these safety instructions and all user documentation of the equipment prior to working with the equipment at any time. If you do not have the user documentation for your equipment, contact your local Bosch Rexroth representative to send this documentation immediately to the person or persons responsible for the safe operation of this equipment.

If the equipment is resold, rented or transferred or passed on to others, then these safety instructions must be delivered with the equipment.



WARNING

Improper use of this equipment, failure to follow the safety instructions in this document or tampering with the product, including disabling of safety devices, may result in material damage, bodily harm, electric shock or even death!

3.2 Explanations

The safety instructions describe the following degrees of hazard seriousness in compliance with ANSI Z535. The degree of hazard seriousness informs about the consequences resulting from non-compliance with the safety instructions.

| Warning symbol with signal word | Degree of hazard seriousness according to ANSI |
|---------------------------------|--|
| DANGER | Death or severe bodily harm will occur. |
| WARNING | Death or severe bodily harm may occur. |
| CAUTION | Bodily harm or material damage may occur. |

Fig. 3-1: Hazard classification (according to ANSI Z535)

3.3 Hazards by Improper Use



DANGER

**High voltage and high discharge current!
Danger to life or severe bodily harm by electric shock!**



DANGER

Dangerous movements! Danger to life, severe bodily harm or material damage by unintentional motor movements!



WARNING

High electrical voltage due to wrong connections! Danger to life or bodily harm by electric shock!



WARNING

Health hazard for persons with heart pacemakers, metal implants and hearing aids in proximity to electrical equipment!



CAUTION

Surface of machine housing could be extremely hot! Danger of injury! Danger of burns!



CAUTION

Risk of injury due to improper handling! Bodily harm caused by crushing, shearing, cutting and mechanical shock or incorrect handling of pressurized systems!



CAUTION

Risk of injury due to incorrect handling of batteries!

3.4 General Information

- Bosch Rexroth AG is not liable for damages resulting from failure to observe the warnings provided in this documentation.
- Read the operating, maintenance and safety instructions in your language before starting up the machine. If you find that you cannot completely understand the documentation for your product, please ask your supplier to clarify.
- Proper and correct transport, storage, assembly and installation as well as care in operation and maintenance are prerequisites for optimal and safe operation of this equipment.
- Only persons who are trained and qualified for the use and operation of the equipment may work on this equipment or within its proximity.
 - The persons are qualified if they have sufficient knowledge of the assembly, installation and operation of the equipment as well as an understanding of all warnings and precautionary measures noted in these instructions.
 - Furthermore, they must be trained, instructed and qualified to switch electrical circuits and equipment on and off in accordance with technical safety regulations, to ground them and to mark them according to the requirements of safe work practices. They must have adequate safety equipment and be trained in first aid.
- Only use spare parts and accessories approved by the manufacturer.
- Follow all safety regulations and requirements for the specific application as practiced in the country of use.
- The equipment is designed for installation in industrial machinery.
- The ambient conditions given in the product documentation must be observed.
- Use only safety features and applications that are clearly and explicitly approved in the Project Planning Manual.
For example, the following areas of use are not permitted: construction cranes, elevators used for people or freight, devices and vehicles to transport people, medical applications, refinery plants, transport of hazardous goods, nuclear applications, applications sensitive to high frequency, mining, food processing, control of protection equipment (also in a machine).
- The information given in the documentation of the product with regard to the use of the delivered components contains only examples of applications and suggestions.
The machine and installation manufacturer must
 - make sure that the delivered components are suited for his individual application and check the information given in this documentation with regard to the use of the components,
 - make sure that his application complies with the applicable safety regulations and standards and carry out the required measures, modifications and complements.
- Startup of the delivered components is only permitted once it is sure that the machine or installation in which they are installed complies with the national regulations, safety specifications and standards of the application.
- Technical data, connections and operational conditions are specified in the product documentation and must be followed at all times.

- Operation is only permitted if the national EMC regulations for the application are met.
The instructions for installation in accordance with EMC requirements can be found in the documentation "EMC in Drive and Control Systems".
The machine or installation manufacturer is responsible for compliance with the limiting values as prescribed in the national regulations.

3.5 Protection Against Contact with Electrical Parts

Note: This section refers to equipment and drive components with voltages above 50 Volts.

Touching live parts with voltages of 50 Volts and more with bare hands or conductive tools or touching ungrounded housings can be dangerous and cause electric shock. In order to operate electrical equipment, certain parts must unavoidably have dangerous voltages applied to them.



DANGER

High electrical voltage! Danger to life, severe bodily harm by electric shock!

- ⇒ Only those trained and qualified to work with or on electrical equipment are permitted to operate, maintain or repair this equipment.
 - ⇒ Follow general construction and safety regulations when working on high voltage installations.
 - ⇒ Before switching on power the ground wire must be permanently connected to all electrical units according to the connection diagram.
 - ⇒ Do not operate electrical equipment at any time, even for brief measurements or tests, if the ground wire is not permanently connected to the points of the components provided for this purpose.
 - ⇒ Before working with electrical parts with voltage higher than 50 V, the equipment must be disconnected from the mains voltage or power supply. Make sure the equipment cannot be switched on again unintended.
 - ⇒ The following should be observed with electrical drive and filter components:
 - ⇒ Wait five (5) minutes after switching off power to allow capacitors to discharge before beginning to work. Measure the voltage on the capacitors before beginning to work to make sure that the equipment is safe to touch.
 - ⇒ Never touch the electrical connection points of a component while power is turned on.
 - ⇒ Install the covers and guards provided with the equipment properly before switching the equipment on. Prevent contact with live parts at any time.
 - ⇒ A residual-current-operated protective device (RCD) must not be used on electric drives! Indirect contact must be prevented by other means, for example, by an overcurrent protective device.
 - ⇒ Electrical components with exposed live parts and uncovered high voltage terminals must be installed in a protective housing, for example, in a control cabinet.
-

To be observed with electrical drive and filter components:



DANGER

**High electrical voltage on the housing!
High leakage current! Danger to life, danger of
injury by electric shock!**

- ⇒ Connect the electrical equipment, the housings of all electrical units and motors permanently with the safety conductor at the ground points before power is switched on. Look at the connection diagram. This is even necessary for brief tests.
- ⇒ Connect the safety conductor of the electrical equipment always permanently and firmly to the supply mains. Leakage current exceeds 3.5 mA in normal operation.
- ⇒ Use a copper conductor with at least 10 mm² cross section over its entire course for this safety conductor connection!
- ⇒ Prior to startups, even for brief tests, always connect the protective conductor or connect with ground wire. Otherwise, high voltages can occur on the housing that lead to electric shock.

3.6 Protection Against Electric Shock by Protective Low Voltage (PELV)

All connections and terminals with voltages between 0 and 50 Volts on Rexroth products are protective low voltages designed in accordance with international standards on electrical safety.



WARNING

**High electrical voltage due to wrong
connections! Danger to life, bodily harm by
electric shock!**

- ⇒ Only connect equipment, electrical components and cables of the protective low voltage type (PELV = Protective Extra Low Voltage) to all terminals and clamps with voltages of 0 to 50 Volts.
- ⇒ Only electrical circuits may be connected which are safely isolated against high voltage circuits. Safe isolation is achieved, for example, with an isolating transformer, an opto-electronic coupler or when battery-operated.

3.7 Protection Against Dangerous Movements

Dangerous movements can be caused by faulty control of the connected motors. Some common examples are:

- improper or wrong wiring of cable connections
- incorrect operation of the equipment components
- wrong input of parameters before operation
- malfunction of sensors, encoders and monitoring devices
- defective components
- software or firmware errors

Dangerous movements can occur immediately after equipment is switched on or even after an unspecified time of trouble-free operation.

The monitoring in the drive components will normally be sufficient to avoid faulty operation in the connected drives. Regarding personal safety, especially the danger of bodily injury and material damage, this alone cannot be relied upon to ensure complete safety. Until the integrated monitoring functions become effective, it must be assumed in any case that faulty drive movements will occur. The extent of faulty drive movements depends upon the type of control and the state of operation.



Dangerous movements! Danger to life, risk of injury, severe bodily harm or material damage!

- ⇒ Ensure personal safety by means of qualified and tested higher-level monitoring devices or measures integrated in the installation. Unintended machine motion is possible if monitoring devices are disabled, bypassed or not activated.
- ⇒ Pay attention to unintended machine motion or other malfunction in any mode of operation.
- ⇒ Keep free and clear of the machine's range of motion and moving parts. Possible measures to prevent people from accidentally entering the machine's range of motion:
 - use safety fences
 - use safety guards
 - use protective coverings
 - install light curtains or light barriers
- ⇒ Fences and coverings must be strong enough to resist maximum possible momentum, especially if there is a possibility of loose parts flying off.
- ⇒ Mount the emergency stop switch in the immediate reach of the operator. Verify that the emergency stop works before startup. Don't operate the machine if the emergency stop is not working.
- ⇒ Isolate the drive power connection by means of an emergency stop circuit or use a starting lockout to prevent unintentional start.
- ⇒ Make sure that the drives are brought to a safe standstill before accessing or entering the danger zone. Safe standstill can be achieved by switching off the power supply contactor or by safe mechanical locking of moving parts.

- ⇒ Secure vertical axes against falling or dropping after switching off the motor power by, for example:
 - mechanically securing the vertical axes
 - adding an external braking/ arrester/ clamping mechanism
 - ensuring sufficient equilibration of the vertical axes
 The standard equipment motor brake or an external brake controlled directly by the drive controller are not sufficient to guarantee personal safety!
- ⇒ Disconnect electrical power to the equipment using a master switch and secure the switch against reconnection for:
 - maintenance and repair work
 - cleaning of equipment
 - long periods of discontinued equipment use
- ⇒ Prevent the operation of high-frequency, remote control and radio equipment near electronics circuits and supply leads. If the use of such equipment cannot be avoided, verify the system and the installation for possible malfunctions in all possible positions of normal use before initial startup. If necessary, perform a special electromagnetic compatibility (EMC) test on the installation.

3.8 Protection Against Magnetic and Electromagnetic Fields During Operation and Mounting

Magnetic and electromagnetic fields generated near current-carrying conductors and permanent magnets in motors represent a serious health hazard to persons with heart pacemakers, metal implants and hearing aids.



WARNING

Health hazard for persons with heart pacemakers, metal implants and hearing aids in proximity to electrical equipment!

- ⇒ Persons with heart pacemakers, hearing aids and metal implants are not permitted to enter the following areas:
 - Areas in which electrical equipment and parts are mounted, being operated or started up.
 - Areas in which parts of motors with permanent magnets are being stored, operated, repaired or mounted.
- ⇒ If it is necessary for a person with a heart pacemaker to enter such an area, then a doctor must be consulted prior to doing so. Heart pacemakers that are already implanted or will be implanted in the future, have a considerable variation in their electrical noise immunity. Therefore there are no rules with general validity.
- ⇒ Persons with hearing aids, metal implants or metal pieces must consult a doctor before they enter the areas described above. Otherwise, health hazards will occur.

3.9 Protection Against Contact with Hot Parts



CAUTION

**Housing surfaces could be extremely hot!
Danger of injury! Danger of burns!**

- ⇒ Do not touch housing surfaces near sources of heat! Danger of burns!
 - ⇒ After switching the equipment off, wait at least ten (10) minutes to allow it to cool down before touching it.
 - ⇒ Do not touch hot parts of the equipment, such as housings with integrated heat sinks and resistors. Danger of burns!
-

3.10 Protection During Handling and Mounting

Under certain conditions, incorrect handling and mounting of parts and components may cause injuries.



CAUTION

Risk of injury by incorrect handling! Bodily harm caused by crushing, shearing, cutting and mechanical shock!

- ⇒ Observe general installation and safety instructions with regard to handling and mounting.
 - ⇒ Use appropriate mounting and transport equipment.
 - ⇒ Take precautions to avoid pinching and crushing.
 - ⇒ Use only appropriate tools. If specified by the product documentation, special tools must be used.
 - ⇒ Use lifting devices and tools correctly and safely.
 - ⇒ For safe protection wear appropriate protective clothing, e.g. safety glasses, safety shoes and safety gloves.
 - ⇒ Never stand under suspended loads.
 - ⇒ Clean up liquids from the floor immediately to prevent slipping.
-

3.11 Battery Safety

Batteries contain reactive chemicals in a solid housing. Inappropriate handling may result in injuries or material damage.



CAUTION

Risk of injury by incorrect handling!

- ⇒ Do not attempt to reactivate discharged batteries by heating or other methods (danger of explosion and cauterization).
- ⇒ Never charge non-chargeable batteries (danger of leakage and explosion).
- ⇒ Never throw batteries into a fire.
- ⇒ Do not dismantle batteries.
- ⇒ Do not damage electrical components installed in the equipment.

Note: Be aware of environmental protection and disposal! The batteries contained in the product should be considered as hazardous material for land, air and sea transport in the sense of the legal requirements (danger of explosion). Dispose batteries separately from other waste. Observe the legal requirements in the country of installation.

3.12 Protection Against Pressurized Systems

Certain motors and drive controllers, corresponding to the information in the respective Project Planning Manual, must be provided with pressurized media, such as compressed air, hydraulic oil, cooling fluid and cooling lubricant supplied by external systems. Incorrect handling of the supply and connections of pressurized systems can lead to injuries or accidents. In these cases, improper handling of external supply systems, supply lines or connections can cause injuries or material damage.



CAUTION

Danger of injury by incorrect handling of pressurized systems !

- ⇒ Do not attempt to disassemble, to open or to cut a pressurized system (danger of explosion).
- ⇒ Observe the operation instructions of the respective manufacturer.
- ⇒ Before disassembling pressurized systems, release pressure and drain off the fluid or gas.
- ⇒ Use suitable protective clothing (for example safety glasses, safety shoes and safety gloves)
- ⇒ Remove any fluid that has leaked out onto the floor immediately.

Note: Environmental protection and disposal! The media used in the operation of the pressurized system equipment may not be environmentally compatible. Media that are damaging the environment must be disposed separately from normal waste. Observe the legal requirements in the country of installation.

Notes

4 Technical Data

4.1 Front Panel

| | |
|------------------------------|--|
| Display | 15" TFT, 1024 x 768 pixels, 256,000 colors |
| Operation | Traffic white |
| Surface – Front panel | Keypad |
| Degree of protection | Front panel IP 54 |
| Interface | USB connection, cover's degree of protection IP 54 |

Fig. 4-1: Technical data, front VDP 92.1

4.2 Power Supply

The VDP 92.1 is provided by the industrial PC via the G4 display interface with a voltage of 24 VDC. The maximum power consumption is 2 A.

4.3 Ambient Conditions

| | In operation | Storage/Transport |
|----------------------------------|---|--|
| Max. surrounding air temperature | +5 °C... +45 °C | -20 °C to +60 °C |
| Max. temperature gradient | Temporal temperature changes up to 3 °C per minute | Not defined |
| Relative humidity | Climatic class 3K3 according to EN 60721, condensation not permissible. | Climatic class 3K3 according to EN 60721, condensation not permissible. |
| Air pressure | Up to 2,000 m above MSL according to DIN 60204 | |
| Mechanical strength | Max. vibration: Frequency range: 10...150 Hz Excursion: 0.075 mm at 10...57 Hz Acceleration: 1 g at 57...150 Hz According to EN 60068-2-6 | Max. shock: 15 g according to DIN IEC 68-2-27, no disturbance of the function |

Fig. 4-2: Ambient conditions

4.4 Used Standards

The system components of the displays correspond to the following standards:

EN Standards

| Standard | Meaning |
|---------------|---|
| EN 60 204-1 | Electrical equipment of machines |
| EN 50 081-2 | Basic technical standard, emitted interference (industrial environment) |
| EN 50 082-2 | Basic technical standard, noise immunity (industrial environment) |
| EN 60 742 | Transformer for 24 V power supply unit, protective separation |
| EN 60 950 | Overvoltage category II |
| EN 61 131 | Requirements concerning the 24 V outputs |
| EN 61 131-2 | Requirements concerning the 24 power supply |
| EN 418 | Machine safety, EMERGENCY STOP devices |
| EN 60 529 | Degrees of protection (incl. housings and installation compartments) |
| EN 60 068-2-6 | Vibration test |
| EN 60068-2-27 | Shock test |

Fig. 4-3: Used standards

CE Marking

Note: Concerning delivered VDP displays all CE requirements are fulfilled.

UL/CSA Certification

The VDP 92.1 device is certified according to

- **UL508** (Industrial Control Equipment) and
- **C22.2 No. 142-M1987** (CSA)



However, it is possible that there are combinations or extension stages with restricted or missing certification. Thus, verify the registration according to the UL marking on the device.

Note: To guarantee an UL/CSA-compliant operation, you have to fulfill the following conditions:

- Use 60/75 °C copper wire only.

Note: The UL/CSA marking is only valid for the device in its delivery status. After having modified the device the UL compliancy has to be verified.

4.5 Wear Parts

Wear Parts without Warranty The service life of the **backlight** is limited to a certain number of operating hours. After this time the backlight will produce only 50 % of its original brightness. This time differs for the used displays:

| Display seize | Service life |
|---------------|--------------|
| 15" | 30,000 hours |

Fig. 4-4: Service life of the backlight

- Also **fans** are mechanic wear components, whose service life is extremely temperature-dependent. For the fan the manufacturer specifies the following service life:

| Surrounding air temperature | Service life |
|-----------------------------|--------------|
| 20 °C | 45,000 hours |
| 60 °C | 15,000 hours |

Fig. 4-5: Service life of the fan

4.6 Compatibility Test

All Rexroth controls and drives are developed and tested according to the latest state-of-the-art.

As it is impossible to follow the continuing development of all materials (e.g. lubricants in machine tools) which may interact with our controls and drives, it cannot be completely ruled out that any reactions with the materials used by Bosch Rexroth might occur.

For that reason, test new lubricants, cleaning agents, etc. for compatibility with our housings / our housing materials before using the particular material concerned.

5 Dimensions

5.1 Housing Dimensions

Housing Dimensions of the VDP 92.1, Front and Side View

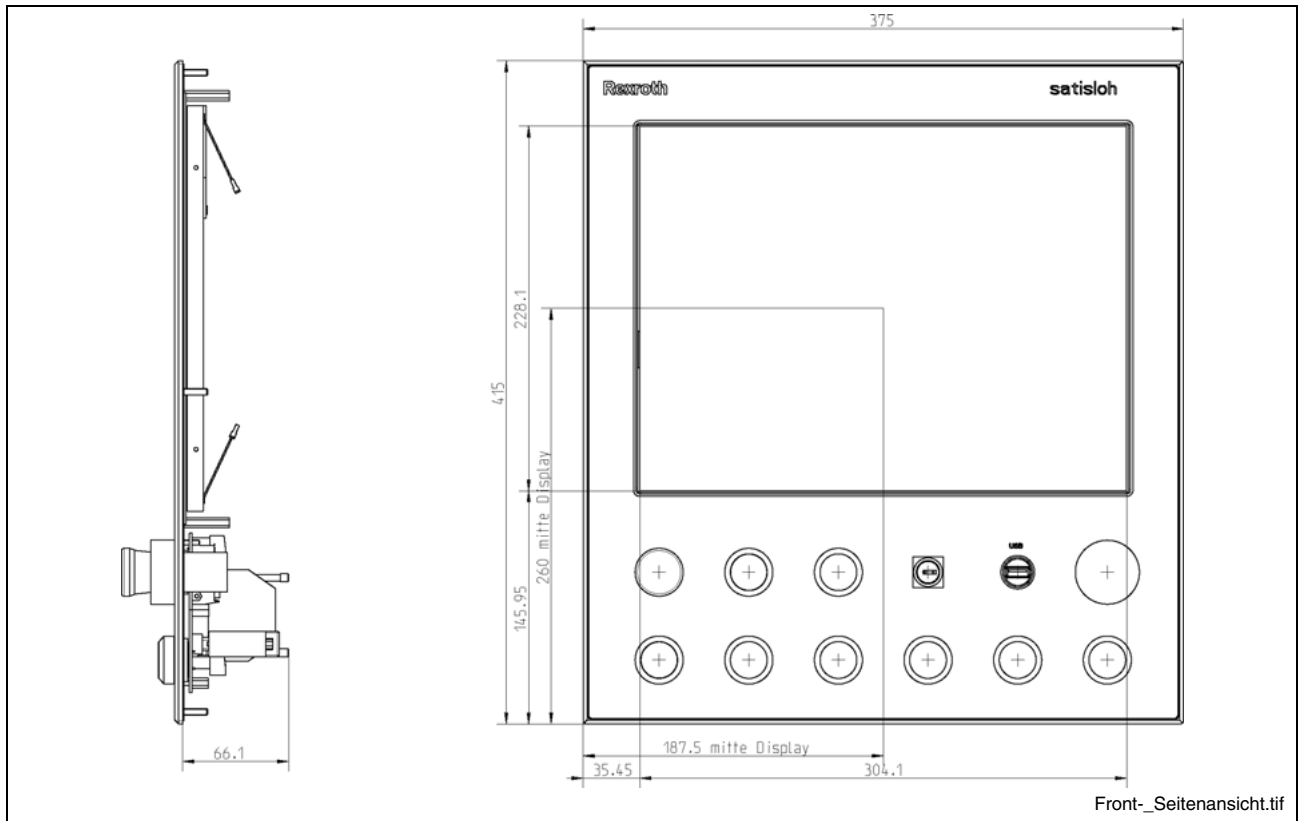

Fig. 5-1: Housing dimensions of the VDP 92.1, front and side view

Housing Dimensions of the VDP 92.1, Rear and Side View

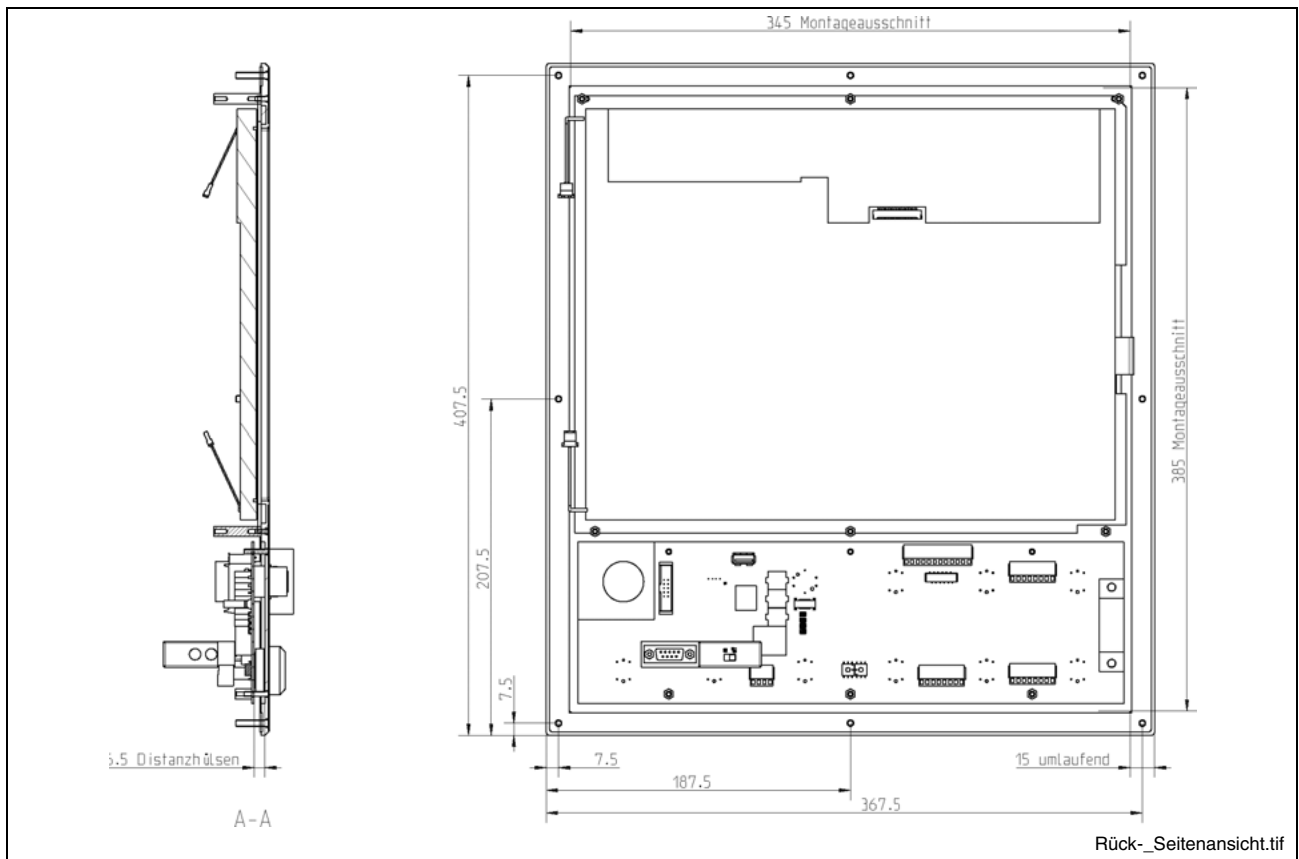

Fig. 5-2: Housing dimensions of the VDP 92.1, rear and side view

5.2 Installation

Installation Notes

When installing the operator panel observe to ensure an ergonomic operation. Additionally, ensure that all moving machine components are in sight of the operator.

Avoid installation locations exposed to direct sunlight, as additional heat development can occur.

Install the operator panel in a manner ensuring easy access to the front panel (top side).

Lay all connecting cables in loops and use strain reliefs for all cables.

Keep a suitably large distance from sources of interference.

Mounting Cut-Out

To mount the operator panel proceed as follows:

1. Create a mounting cut-out with 8 holes, diameter 4.5 mm.
2. Insert the operator panel from the front into the cut-out. Then insert the mounting bolts M4 into the drilled holes.
3. Fasten the operator panel by screwing the nuts at the rear side of the mounting bolts.

6 Interfaces

6.1 View on the Connector Panel

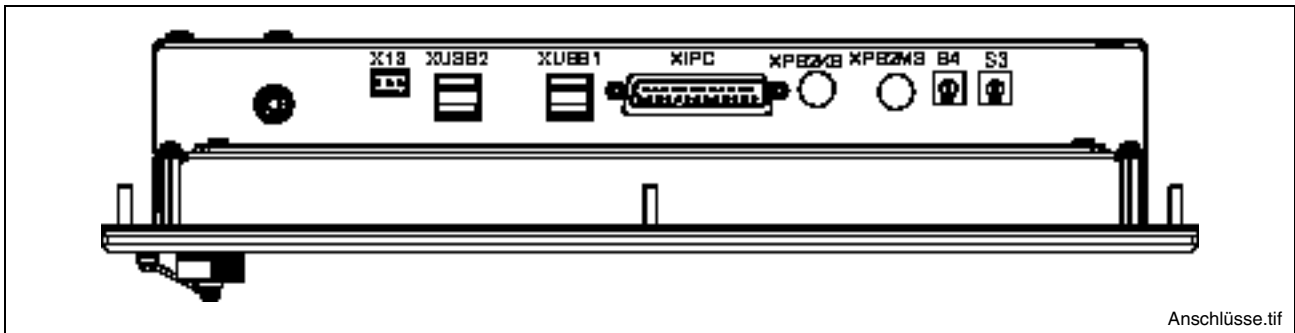

Fig. 6-1: Position of the interfaces

6.2 Description of the Interfaces

| Designation at the housing | Type of connection | Type of connector (integrated) | Mating connector or cable (from outside) |
|----------------------------|---|---|---|
| X13 | 24 VDC – Power supply (required when using an Y-repeater) | Weidmüller male connector terminal, MSTB 1.5, 3-pin | Weidmüller female connector terminal, MSTB 1.5, 3-pin |
| XUSB1 | 2 USB interfaces | USB female connector, 4-pin, type A | USB male connector, 4-pin |
| XUSB2 | 2 USB interfaces | USB female connector, 4-pin, type A | USB male connector, 4-pin |
| XIPC | GIGASTAR interface (connection to industrial PC) | D-Sub male connector, 25-pin | D-Sub female connector, 25-pin |
| XPS2KB | PS/2 keyboard connection | Mini-DIN PS/2 female connector, 6-pin | Mini-DIN PS/2 male connector, 6-pin |
| XPS2MS | PS/2 mouse connection | Mini-DIN PS/2 female connector, 6-pin | Mini-DIN PS/2 male connector, 6-pin |

Fig. 6-2: Interfaces at IndraControl VDP 16.2 and IndraControl VDP 40.2

6.3 24 VDC Power Supply

The VDP is provided with the necessary power via the G4 display interface of the industrial PC.

Only if the VDP is connected with the IndraControl VPB 40 / IndraControl VSB 40 via an Y-repeater, the VDP has to be provided with 24 V via X13!

X13 – 24 V Power Supply

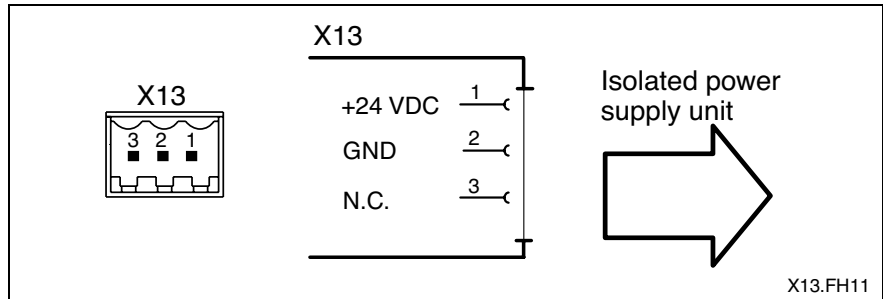

Fig. 6-3: 24 VDC power supply X13

| Pin | Function |
|-----|----------|
| 1 | +24 V |
| 2 | GND |
| 3 | N.C. |

To provide the device with power, you can use a commercially available 24 V industrial power supply unit.

Note: An isolated power supply unit has to be used, as pin 2 is internally connected with the housing.

6.4 USB Interfaces

XUSB – Serial Interfaces for Printer, Scanner and CD-ROM Drive

The devices feature two USB interfaces on the connector panel (XUSB1 and XUSB2) and one in the front panel (not for devices for the food industry).

Note: The maximum power consumption of the connected device must not exceed 500 mA. If the load exceeds 500 mA, the internal current monitoring is activated.

Note: The USB interfaces are not supported by the operating system Windows NT4.0.

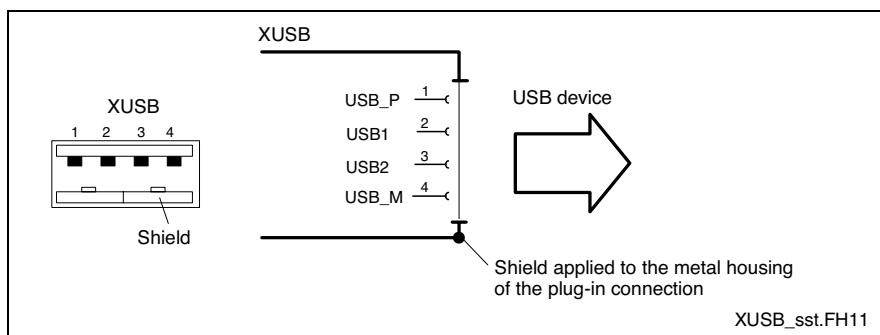

Fig. 6-4: USB interfaces XUSB1 and XUSB2

| Pin | Function |
|-----|--------------------------------|
| 1 | USB power supply (max. 500 mA) |
| 2 | Data - |
| 3 | Data + |
| 4 | USB ground |

Note: It is only possible to connect USB devices fulfilling the USB specification. However, USB devices that e. g., don't maintain the specified reaction time are also commercially available.

Thus, the general function of non-specification-compatible USB devices is not guaranteed.

6.5 G4 Display Interface

XIPC – GIGASTAR Interface The VDP is connected to the industrial PC via the 25-pin G4 display interface (XIPC).



CAUTION

Material damage by cable extension!

⇒ The cables must not be plugged together for extension purposes, as this might damage the VDP.

Material damage by plugging in/off under voltage!

⇒ G4 cable may only be plugged in/off in no-voltage condition.

6.6 Combined Keyboard/Mouse Interface

The combined keyboard/mouse interface (XPS2KB) allows to connect an external keyboard/mouse. The data are transmitted via the G4 display interface to the industrial PC.

XPS2KB – PS/2 Mini DIN Keyboard/Mouse Interface

| | |
|--|---|
| PS/2 Mini DIN female connector, 6-pin | |
| Cable length: | Max. 1.5 m |
| Cable type: | Shielded, cross section min. 0.14 mm ² |

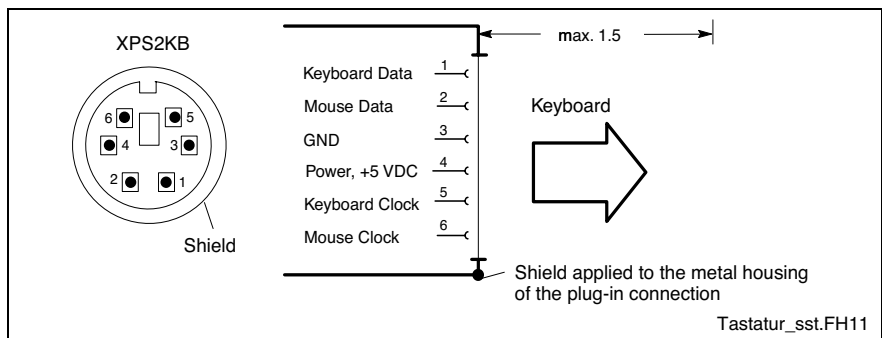

Fig. 6-5: Combined keyboard/mouse interface XPS2KB

6.7 Mouse Interface

The mouse interface (XPS2MS) can be connected to an external mouse. The data are transmitted via the G4 display interface to the industrial PC.

XPS2MS – PS/2 Mouse Interface

| | |
|--|--|
| PS/2 Mini DIN female connector, 6-pin | |
| Cable length: | Max. 1.5 m |
| Cable type: | Shielded, cross section min. 0.14 mm ² |
| Interrupt (IRQ): | 12 |
| BIOS presettings: | PS/2 mouse support: Enabled PS/2 mouse: Auto detect |

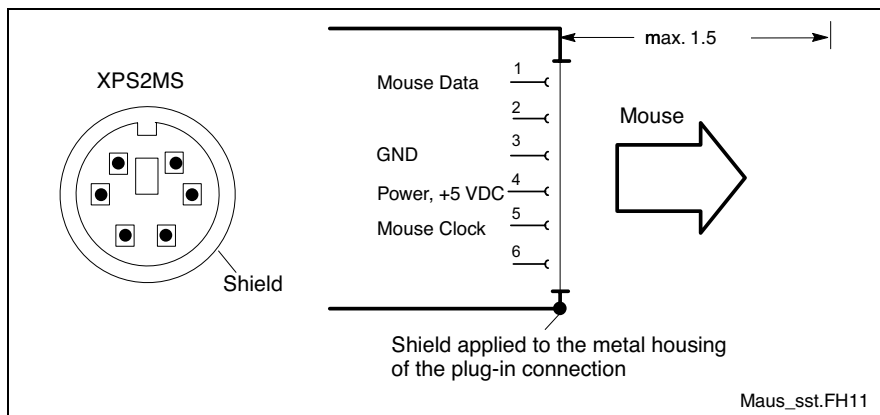

Fig. 6-6: Mouse interface XPS2MS

If a PS/2 mouse is not recognized by the system, the mouse has to be activated in the BIOS by switching from "Disabled" to "Autodetect". The operating system will not recognize the plugging-in of an external mouse after completed startup, because the mouse initialization occurs during the booting process.

Note: If you use a mouse, please ensure that it is appropriate for industrial use. Most of the mice designed for the use in offices are very susceptible to electromagnetic disturbances.

Note: The connected mouse must be PS/2-compatible. Normally, the BIOS reserves IRQ 12 for the PS/2 mouse. If there are address conflicts, e. g., if IRQ 12 has already been used by another PC extension card, you should change the IRQ of this extension card to another IRQ, that is still not-assigned.

Note: If a keyboard with mouse is connected to the VDP, no further mouse may be connected to the mouse interface.

6.8 Connector Panel of the Profibus Interface

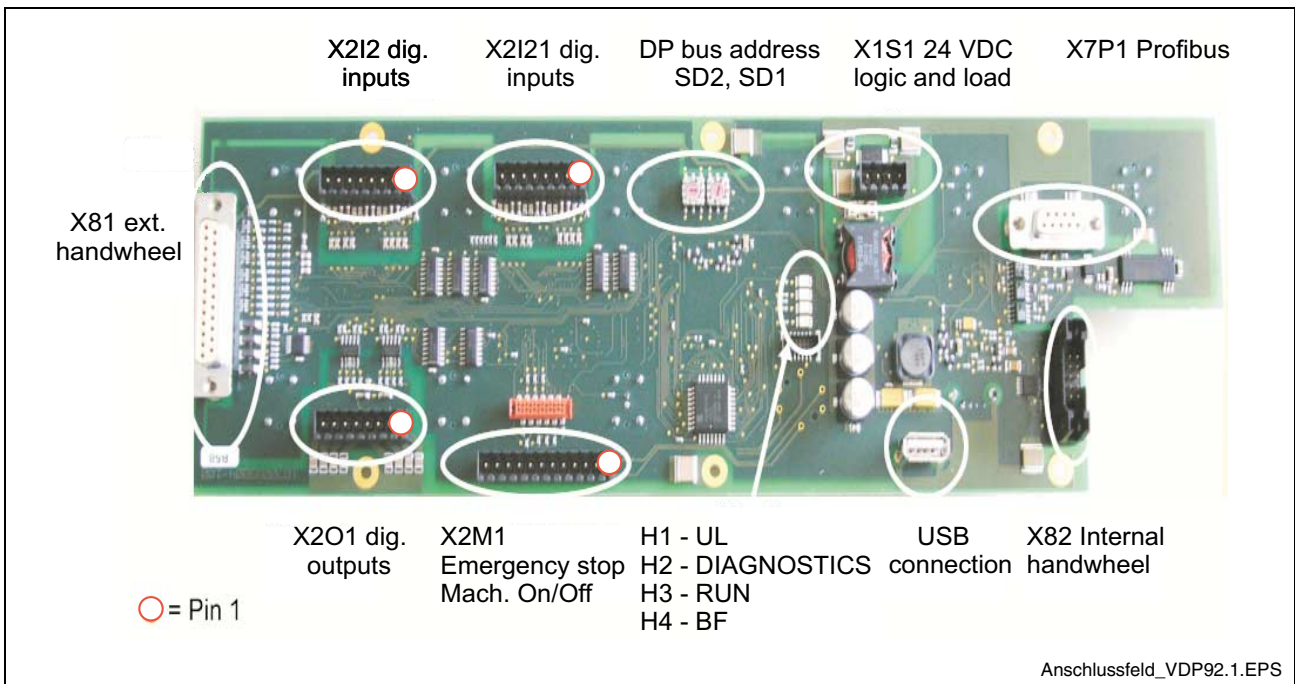

Fig. 6-7: Connector panel

6.9 Protective Earth Terminal

Ensure that during the wiring of the protective conductor the wire cross-section is sufficient. For this, consider also EN 60204 Part 1 (max. electric resistance and verification of the protective conductor's wiring).



Dangerous shock currents caused by insufficient protective conductor connection!

⇒ Protective conductor connections must not be affected by mechanical, chemical or electrochemical influences. The connection must be durable.

6.10 Current and Voltage Supply (X1S1)

4-pin Weidmüller Male Connector

A 4-pin Weidmüller male connector (3.5 pin spacing) with the following pin assignment serves to connect the voltage supply:

| Connectors | Pin | Signals | Meaning |
|------------|-----|-----------|-----------------------------------|
| X1S1 | 1 | U_Q | +24 VDC Input/Output supply U_Q |
| | 2 | 0 V U_Q | 0 V Input/Output supply U_Q |
| | 3 | U_L | +24 VDC Logic supply U_L |
| | 4 | 0 V U_L | 0 V Logic supply U_L |

Fig. 6-8: Pin assignment X1S1

Fuses The supplies at X10 are protected by two SMD fuses F1 and F2.

6.11 Field Bus Interface PROFIBUS DP (X7P1)

Connector X7P1 provides at connection VP 5 V / 100 mA ISO voltage. Do not use any bus terminating resistors, but only a bus load. Thus, the connection of a hand-held terminal or an Optical Link Plug (OLP) [conversion RS485/Opto] is possible.

Optical PROFIBUS networks in ring topology can be established with the help of the OLP.

General Information

| Type | RS485 |
|-----------------------|------------------------------------|
| Electrical isolation | Yes |
| Baud rate | Up to 12 Mbauds |
| 2 BCD rotary switches | Station address 1-99 |
| Connector X7P1 | 9-pin female connector strip D-SUB |

Fig. 6-9: Field bus interface PROFIBUS DP accord. to EN 50170, Part 2 (DP)

Pin Assignment

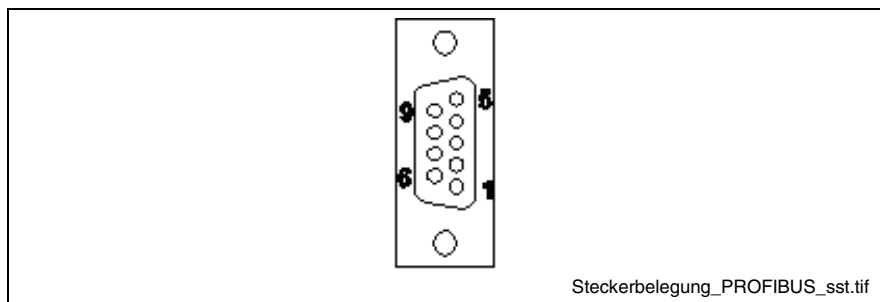

Fig. 6-10: Pin assignment of the PROFIBUS DP interface

| Connector | Pin | RS485 reference | Signal | Meaning |
|-----------|-----|-----------------|-----------|----------------------------------|
| X71 | 1 | - | - | - |
| | 2 | - | - | - |
| | 3 | B/B' | RxD/TxD-P | Receiving/Transmitting data |
| | 4 | | CNTR_P | Repeater control signal |
| | 5 | C/C' | DGND | Data reference potential (M 5 V) |
| | 6 | | VP | Supply voltage plus (P 5 V) |
| | 7 | - | - | - |
| | 8 | A/A' | RxD/TxD-N | Receiving/Transmitting data N |
| | 9 | | DGND | Data reference potential (M 5 V) |

Fig. 6-11: Pin assignment of the PROFIBUS DP interface

Note: Ensure that potential equalizing currents don't flow over the shield conductor of the interface line. Therefore, provide for a proper potential equalization between the devices to be connected already before the first commissioning.

6.12 Digital 24 V Inputs and Outputs (X2I1, X2I2, X2O1)

The VDP 92.1 assembly provides 16 digital 24 V inputs and 8 digital 24 V outputs. The connectors of the inputs and outputs are on the logic board.

Pin Assignment (3 x 8-Pin Weidmüller Connector, 3.5 pin spacing)

| Connectors | Pin | Signal | Meaning |
|------------|-----|--------|--------------------------------|
| X2I1 | 1 | I0 | Digital 24 V inputs I 0 – I 7 |
| | 2 | I1 | |
| | 3 | I2 | |
| | 4 | I3 | |
| | 5 | I4 | |
| | 6 | I5 | |
| | 7 | I6 | |
| | 8 | I7 | |
| X2I2 | 1 | I8 | Digital 24 V inputs I 8 – I 15 |
| | 2 | I9 | |
| | 3 | I10 | |
| | 4 | I11 | |
| | 5 | I12 | |
| | 6 | I13 | |
| | 7 | I14 | |
| | 8 | I15 | |
| X2O1 | 1 | Q0 | Digital 24 V outputs Q 0 – Q 7 |
| | 2 | Q1 | |
| | 3 | Q2 | |
| | 4 | Q3 | |
| | 5 | Q4 | |
| | 6 | Q5 | |
| | 7 | Q6 | |
| | 8 | Q7 | |

Fig. 6-12: Pin assignment X2I1, X2I2, X2O1

Characteristics of Digital Inputs

| | |
|----------------------------|---------------------------------|
| Input type | Type 1, according to EN 61131-2 |
| Number of inputs | 16 |
| Electrical isolation | Yes (to logic supply) |
| Reverse voltage protection | Yes |
| Plug-in pin spacing | 3.5 (Weidmüller terminal) |

Fig. 6-13: Characteristics of digital inputs

Characteristics of Digital Outputs

| | |
|--|--|
| Output type | Semiconductor outputs, non-saving; protected, with automatic restart, current-carrying |
| Number of outputs | 8 |
| Electrical isolation | Yes (to logic supply) |
| Reverse voltage protection | Only guaranteed without load connection <ul style="list-style-type: none"> Defect of the assembly because of polarity reversal with simultaneous short-circuit of the output lines, polarity reversal with simultaneous connection of externally polarized suppressor diodes at the output lines Applying an external voltage $> U_Q$ |
| Output voltage, nominal value | 24 V |
| Rated output current Nominal value: UL rating: | 0,2 A 0,2 A General Purpose 5 W Tungsten |
| Simultaneity factor | 100 % |
| Plug-in pin spacing | 3.5 (Weidmüller terminal) |

Fig. 6-14: Characteristics of digital outputs

6.13 Key Switches, Machine On/Off, Emergency Stop (X2M1)

On the VDP 92.1 assembly the key switch, the machine-on pushbutton, the machine-off pushbutton and the emergency stop are wired on connector X2M1.

Pin Assignment X2M1 (12-Pin Weidmüller Connector, 3.5 pin spacing)

| Connector | Pin | Signal | Meaning |
|-----------|-----|--------|------------------------------------|
| X211 | 1 | SS21 | Key switch, pin 21 (15 o'clock) |
| | 2 | SS22 | Key switch, pin 22 (15 o'clock) |
| | 3 | SS14 | Key switch, pin 14 (9 o'clock) |
| | 4 | SS11 | Key switch, pin 11 (9 o'clock) |
| | 5 | MAAn1 | Machine On NO contact, pin 1 |
| | 6 | MAAn2 | Machine On NO contact, pin 2 |
| | 7 | MAUs1 | Machine Off NC contact, pin 1 |
| | 8 | MAUs2 | Machine Off NC contact, pin 2 |
| | 9 | NA11 | Emergency stop NC contact 1, pin 1 |
| | 10 | NA12 | Emergency stop NC contact 1, pin 2 |
| | 11 | NA21 | Emergency stop NC contact 2, pin 1 |

Fig. 6-15: Pin assignment X2M1

6.14 Connection for External Hand-held Terminal (X81)

Besides the inputs for the handwheel of the hand-held terminal (A, /A, B, /B) 12 inputs (IN0 – IN11) for the keys of the hand-held terminal are available. The keys are supplied via the "+24 V" supply via connector X81.

The "+24 V" supply is generated by the supply "UL" and may only be used to connect the keys of the hand-held terminal. Connection X81 for the hand-held terminal is located on the logic circuit.

The states of the inputs and the counter value of the handwheel are transmitted to the master control via PROFIBUS DP.

Pin Assignment (25-Pin Female Connector Strip D-SUB)

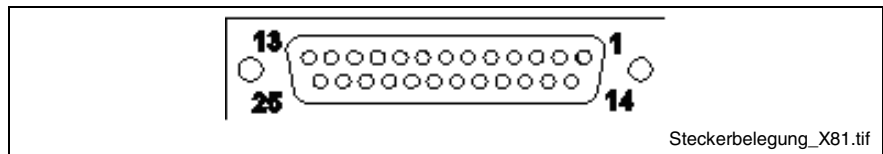

Fig. 6-16: Pin assignment X81

| Plug-in connector, 24-pin HBA – 072910 | | D-Sub, 25-pin VDP92.1 X81 | |
|--|---------------------------------------|---------------------------|---|
| PIN | Signal | Pin | Signal |
| 1 | S1: Emergency Stop, channel 1 | | The connection of S1, S2 and S3 are not connected on the X81. They have to be separately wired. |
| 2 | S1: Emergency Stop, channel 2 | | |
| 3 | S1: Emergency Stop, channel 2 | | |
| 4 | S1: Emergency Stop, channel 1 | | |
| 5 | S3: Enabling pushbutton, right | | |
| 6 | S2: Enabling pushbutton, left | | |
| 7 | Common for enabling pushbutton S2, S3 | | |
| 8 | S10: Stepping switch, right C | 3 | IN2 (24 V input) |
| 9 | S10: Stepping switch, right B | 15 | IN1 (24 V input) |
| 10 | S10: Stepping switch, right A | 2 | IN0 (24 V input) |
| 11 | S4: Key + | 4 | IN4 (24 V input) |
| 12 | S5: Key - | 17 | IN5 (24 V input) |
| 13 | S6: Key ~ | 5 | IN6 (24 V input) |
| 14 | S7: Key F1 | 18 | IN7 (24 V input) |
| 15 | S8: Key F2 | 6 | IN8 (24 V input) |
| 16 | + 24 VDC (Common for S4-S10) | 1 | +24 VDC (24 V supply) |
| 17 | S9: Key F3 | 19 | IN9 (24 V input) |
| 18 | 0 V (handwheel supply -) | 10 | GND |
| 19 | +5 V +/-5 % (handwheel supply +) | 11 | +5 V |
| 20 | Handwheel /B | 12 | /B |
| 21 | Handwheel B | 24 | B |
| 22 | Handwheel /A | 13 | /A |
| 23 | Handwheel A | 25 | A |

| Plug-in connector, 24-pin HBA – 072910 | | D-Sub, 25-pin VDP92.1 X81 | |
|--|---------------------------------|---------------------------|-----------------------|
| PIN | Signal | Pin | Signal |
| 24 | Grounding connection, handwheel | | |
| | | 16 | IN3 (24 V input) |
| | | 7 | IN10 (24 V input) |
| | | 20 | IN11 (24 V input) |
| | | 8 | N.C. |
| | | 9 | N.C. |
| | | 21 | N.C. |
| | | 14 | +24 VDC (24 V supply) |
| | | 22 | GND |
| | | 23 | +5 V |

Fig. 6-17: Wiring diagram

| | |
|--------------------------------|---|
| Handwheel supply | 5 VDC +/-5 % |
| Current consumption, handwheel | Max. 200 mA |
| Max. cable length | Approx. 5 m (depending on the handwheel) |
| Cable type | Twisted pair, separately shielded |
| Inputs | 12 x 24 V input (for switch / pushbutton of the hand-held terminal) |
| Reference device | HBA 072910, by Euchner 100 pulses / revolution; max. 300/min |

Fig. 6-18: Characteristics of the handwheel interface

6.15 Connection for Internal Handwheel (X82)

Connection X82 for the internal handwheel is located on the logic circuit.

The counter value of the handwheel is transmitted to the master control via PROFIBUS DP.

Pin Assignment (6-Pin Weidmüller Connector, 3.5 Pin Spacing)

| Connectors | Pin | Signal | Meaning |
|------------|-----|--------|------------------------------------|
| X82 | 1 | +5 V | +5 VDC +/-5 % handwheel supply (+) |
| | 2 | A | Handwheel channel A |
| | 3 | B | Handwheel channel B |
| | 4 | GND | 0 V handwheel supply (-) |
| | 5 | /A | Handwheel channel A inverse |
| | 6 | /B | Handwheel channel B inverse |

Fig. 6-19: Pin assignment X81

7 Commissioning

7.1 GSD File

The GSD file is provided by Satisloh.

7.2 PROFIBUS DP Address Settings

The station address is set with 2 BCD rotary switches S1 and S2 (see figure below) for the station addresses 1-99. Thereby, S1 represents the tens digit and S2 the ones digit of the station address.

The address must be set in deenergized status.

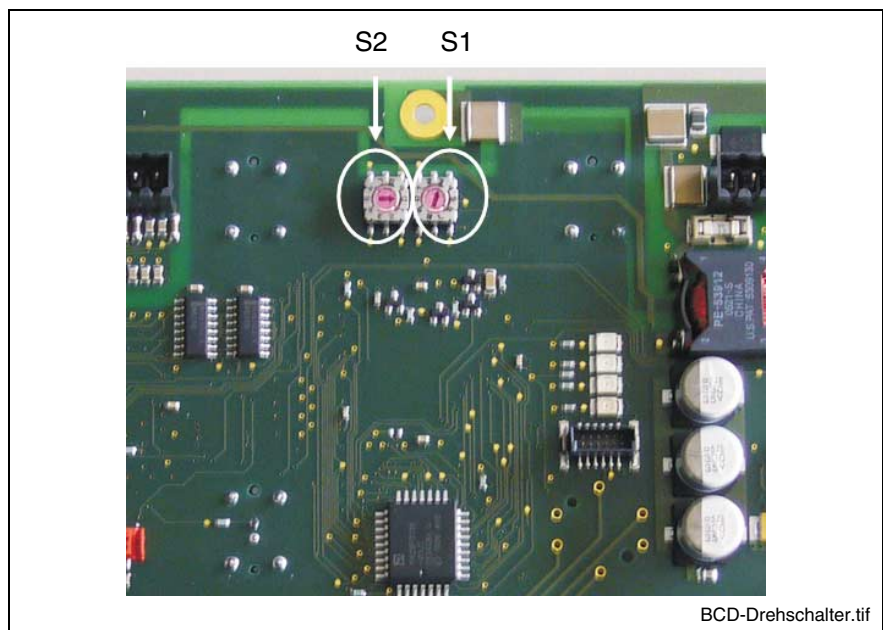

Fig. 7-1: BCD rotary switch S1 and S2

7.3 Baud Rate Setting

The VDP 92.1 recognize automatically the baud rate set at the PROFIBUS DP. Supported are baud rates ranging from 9.6 kbauds to 12 Mbauds:

- 9.6 kbauds
- 19.2 kbauds
- 45.45 kbauds
- 93.75 kbauds
- 187.5 kbauds
- 500 kbauds
- 1.5 Mbauds
- 3 Mbauds
- 6 Mbauds
- 12 Mbauds

7.4 Status Displays

The following figure shows the four status displays H1-H4:

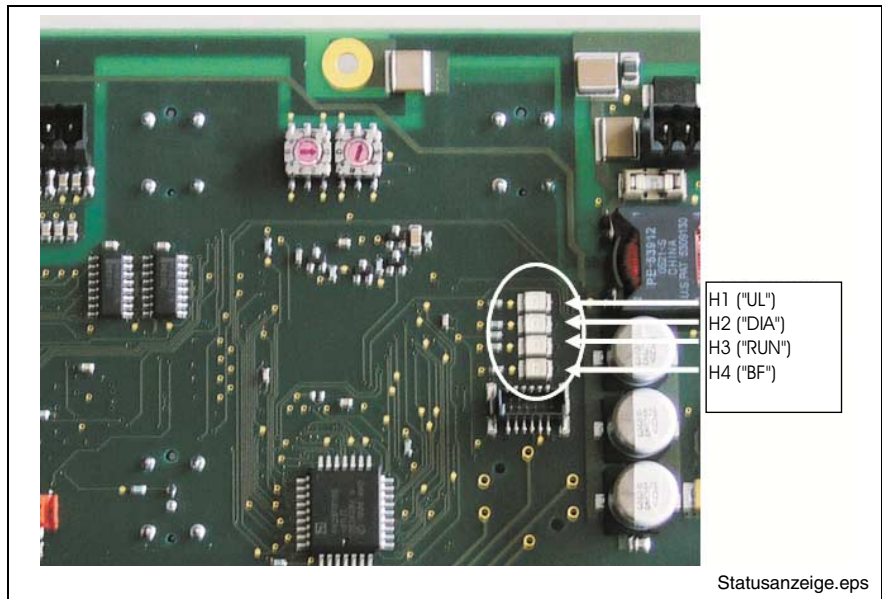

Fig. 7-2: Status displays H1-H4

| Pos | Light-emitting diode | Display | Meaning |
|-----|----------------------|-----------------------------------|--|
| H1 | "UI" | Green Green~ Green~~ Off | 24 V supply (connector X10) 24 V supply is available The bus connection is kept in the initialization phase by one or several modules. System stop (see table system stop) No 24 V supply available |
| H2 | "DIA" | Red Red~ Red~~ Off | Diagnostic display One or several modules indicate a diagnostics. System stop (see table system stop) System stop (see table system stop) No diagnostics or system stop |
| H3 | "RUN" | Green Green~ Off | Operating display Cyclic I/O data exchange (normal operation) Configuration error (command/actual assignment different) The bus connection is not activated by the DP master. Causes: <ul style="list-style-type: none"> Faulty PROFIBUS DP station address The PROFIBUS DP station address is assigned several times at the bus. The response monitoring time is expired. Error in master parameter set (GSD file); e. g. wrong PNO-ID number, wrong buffer seize (Prm, Cfg, ...) |

| Pos | Light-emitting diode | Display | Meaning |
|-----|----------------------|---------|--|
| H4 | "BF" | | Bus error |
| | | Red | The bus connection is searching the baud rate. |
| | | Red~ | Parameterization error (invalid parameterization data) |
| | | Off | The bus connection has recognized and applied the baud rate. |

Green: Static display

Green~: Slow flashing of the display (0.8 s On / 0.2 s Off)

Green~~: Fast flashing of the display (0.125 s On / 0.125 s Off)

Fig. 7-3: Status displays

System Stop

The "System stop" status is indicated with the two light-emitting diodes "UL" and "DIA". During a system stop the outputs are set to the safe status ('0') and the bus traffic to the DP master is interrupted. The system stop can only be quit by a restart of the assembly ('Network on').

| "UL" | "DIA" | Meaning | Measure |
|----------------------|-----------|----------------------------|--|
| Off / green / green~ | Off / red | No system stop | - |
| Green | Red~ | Unknown I/O module | Load new firmware version (service case) |
| Green~~ | Off | Misconfiguration | Verify I/O configuration |
| Off / green | Red~~ | Exceptional error firmware | Service case |
| Green~~ | Red~~ | Exceptional error hardware | Service case |

Fig. 7-4: Display of status "System stop"

System Stop Unknown I/O Module

The VAM has recognized a module, that is not supported by the firmware version of the bus connection.

To operate the I/O module the firmware must be updated.

If an error occurs with the current firmware version, the module has a hardware error.

System Stop 'Misconfiguration'

The following I/O configurations lead to a system stop because of a misconfiguration:

- No I/O modules equipped.
- More than 16 I/O modules equipped.
- More than 64 bytes inputs equipped.
- More than 64 bytes outputs equipped.

The total of the parameterization data of all modules is greater than 64 bytes.

The total of the parameterization data of all modules is greater than 64 bytes.

Exceptional Error 'Hardware' (HW)

When booting ("Network on") the bus connection, the hardware components are tested. Furthermore, during the cyclic operation the I/O configuration and the transmission quality to the I/O modules are monitored. If an error occurs, the assembly is set to system stop "Exceptional error HW".

7.5 Pin Assignment – Digital 24 V Inputs and Outputs

The digital I/O units are mapped at the field bus in module "16DI, 8DO".

PROFIBUS DP Module (GSD File)

| 16DI, 8DO | Format | MSB | | | | | | | | LSB |
|---------------------|--------|-----|-----|-----|-----|-----|-----|----|----|-----|
| Digital outputs 7-0 | BYTE | Q7 | Q6 | Q5 | Q4 | Q3 | Q2 | Q1 | Q0 | |
| Digital inputs 7-0 | BYTE | I7 | I6 | I5 | I4 | I3 | I2 | I1 | I0 | |
| Digital inputs 15-8 | BYTE | I15 | I14 | I13 | I12 | I11 | I10 | I9 | I8 | |

Fig. 7-5: I/O assignment of module 16DI, 8DO

7.6 External Hand-Held Terminal

The inputs of the hand-held terminal (pushbutton and 16-bit counter of the handwheel) are mapped at the field bus in module "Manual Control Unit".

PROFIBUS DP Module (GSD File)

| Manual Control Unit | Format | MSB | | | | | | | | | | | | | | | | LSB |
|---------------------|--------|-----------------------|---|---|---|------|------|-----|-----|-----|-----|-----|-----|-----|-----|-----|-----|-----|
| Handwheel | WORD | Counter value: 16-bit | | | | | | | | | | | | | | | | |
| Pushbutton inputs | WORD | 0 | 0 | 0 | 0 | IN11 | IN10 | IN9 | IN8 | IN7 | IN6 | IN5 | IN4 | IN3 | IN2 | IN1 | IN0 | |

Fig. 7-6: Input assignment for module "Manual Control Unit"

7.7 Internal Handwheel

The 16-bit counter of the handwheel is mapped at the field bus in module "Handwheel".

PROFIBUS DP Module (GSD File)

| Handwheel | Format | MSB | | | | | | | | | | | | | | | | LSB |
|---------------------|--------|----------------------------------|--|--|--|--|--|--|--|--|--|--|--|--|--|--|--|-----|
| Handwheel, internal | WORD | Counter value, handwheel: 16-bit | | | | | | | | | | | | | | | | |

Fig. 7-7: Input assignment for module "Handwheel"

8 Disposal and Environmental Protection

8.1 Disposal

Products

Our products can be returned to us free of charge for disposal. However, it is a precondition that the products are free of oil, grease or other dirt.

Furthermore, the products returned for disposal must not contain any undue foreign matter or foreign component.

Please send the products free domicile to the following address:

Bosch Rexroth AG
Electric Drives and Controls
Bürgermeister-Dr.-Nebel-Straße 2
D-97816 Lohr am Main

Packaging Materials

The packaging materials consist of cardboard, wood and polystyrene. These materials can be easily recycled. For ecological reasons, please refrain from returning the empty packages to us.

8.2 Environmental Protection

No Release of Hazardous Substances

Our products do not contain any hazardous substances, which may be released in the case of appropriate use. Accordingly, our products will normally not have any negative effect on the environment.

Materials Contained in the Products

Electronic Devices

Electronic devices mainly contain:

- steel
- aluminum
- copper
- synthetic materials
- electronic components and modules

Motors

Motors mainly contain:

- steel
- aluminum
- copper
- brass
- magnetic materials
- electronic components and modules

Recycling

Due to their high content of metal most of the product components can be recycled. In order to recycle the metal in the best possible way, the products must be disassembled into individual modules.

Metals contained in electric and electronic modules can also be recycled by means of special separation processes. The synthetic materials remaining after these processes can be thermally recycled.

If the products contain batteries or rechargeable batteries, these batteries are to be removed and disposed before they are recycled.

9 List of Figures

- Fig. 3-1: Hazard classification (according to ANSI Z535) 3-1
- Fig. 4-1: Technical data, front VDP 92.1 4-1
- Fig. 4-2: Ambient conditions 4-1
- Fig. 4-3: Used standards 4-2
- Fig. 4-4: Service life of the backlight 4-3
- Fig. 4-5: Service life of the fan 4-3
- Fig. 5-1: Housing dimensions of the VDP 92.1, front and side view 5-1
- Fig. 5-2: Housing dimensions of the VDP 92.1, rear and side view 5-2
- Fig. 6-1: Position of the interfaces 6-1
- Fig. 6-2: Interfaces at IndraControl VDP 16.2 and IndraControl VDP 40.2 6-1
- Fig. 6-3: 24 VDC power supply X13 6-2
- Fig. 6-4: USB interfaces XUSB1 and XUSB2 6-3
- Fig. 6-5: Combined keyboard/mouse interface XPS2KB 6-4
- Fig. 6-6: Mouse interface XPS2MS 6-5
- Fig. 6-7: Connector panel 6-6
- Fig. 6-8: Pin assignment X1S1 6-6
- Fig. 6-9: Field bus interface PROFIBUS DP accord. to EN 50170, Part 2 (DP) 6-7
- Fig. 6-10: Pin assignment of the PROFIBUS DP interface 6-7
- Fig. 6-11: Pin assignment of the PROFIBUS DP interface 6-7
- Fig. 6-12: Pin assignment X2I1, X2I2, X2O1 6-8
- Fig. 6-13: Characteristics of digital inputs 6-8
- Fig. 6-14: Characteristics of digital outputs 6-9
- Fig. 6-15: Pin assignment X2M1 6-9
- Fig. 6-16: Pin assignment X81 6-10
- Fig. 6-17: Wiring diagram 6-11
- Fig. 6-18: Characteristics of the handwheel interface 6-11
- Fig. 6-19: Pin assignment X81 6-11
- Fig. 7-1: BCD rotary switch S1 and S2 7-1
- Fig. 7-2: Status displays H1-H4 7-2
- Fig. 7-3: Status displays 7-4
- Fig. 7-4: Display of status "System stop" 7-4
- Fig. 7-5: I/O assignment of module 16DI, 8DO 7-5
- Fig. 7-6: Input assignment for module "Manual Control Unit" 7-5
- Fig. 7-7: Input assignment for module "Handwheel" 7-5

10 Service and Support

10.1 Helpdesk

Our service helpdesk at our headquarters in Lohr, Germany, will assist you with all kinds of inquiries.

Contact us:

- By phone through the Service Call Entry Center
Monday to Friday: 7:00 am – 6:00 pm CET
+49 (0) 9352 40 50 60
- By fax
+49 (0) 9352 40 49 41
- By E-mail: service.svc@boschrexroth.de

10.2 Service Hotline

Out of helpdesk ours please contact our German service department directly:

+49 (0) 171 333 88 26

or

+49 (0) 172 660 04 06

Hotline numbers for other countries can be found in the addresses of each region on the Internet (see below).

10.3 Internet

Additional notes regarding service, maintenance and training, as well as the current addresses of our sales and service offices can be found on

<http://www.boschrexroth.com/>

Outwith Germany please contact our sales/service office in your area first.

10.4 Helpful Information

For quick and efficient help please have the following information ready:

- detailed description of the fault and the circumstances
- Information on the name plate of the affected products, especially type codes and serial numbers
- Your phone and fax numbers and E-mail address, so we can contact you in case of questions

Bosch Rexroth AG
Electric Drives and Controls
P.O. Box 13 57
97803 Lohr, Germany
Bgm.-Dr.-Nebel-Str. 2
97816 Lohr, Germany
Phone +49 (0)93 52-40-50 60
Fax +49 (0)93 52-40-49 41
service.svc@boschrexroth.de
www.boschrexroth.com

