

Anbausatz für Sicherheitsschalter
Attachment kit for safety switch
Kit de montage pour commutateur de sécurité
Set per il montaggio dell'interruttore di sicurezza
Juego de montaje para interruptor de seguridad
Jogo de montagem para interruptor de segurança

3 842 523 762/2012-07
Replaces: 2002-10
DE+EN+FR+IT+ES+PT



Montageanleitung • Assembly instructions • Instructions de montage
Istruzioni per il montaggio • Instrucciones de montaje • Instruções de montagem

3 842 522 475

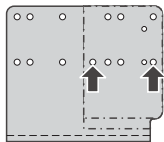
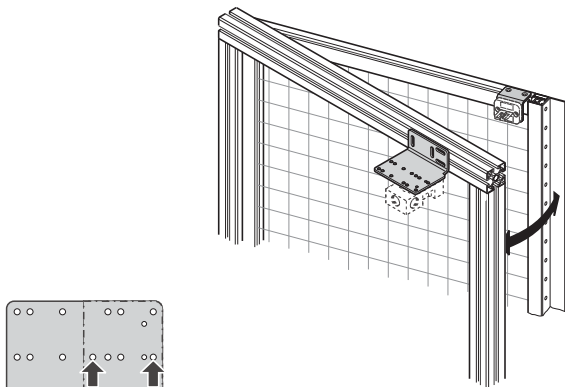

Schmersal AZ 15...
Schmersal AZ 16...

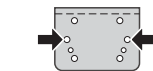

Schmersal AZ 15/16-B...

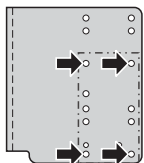
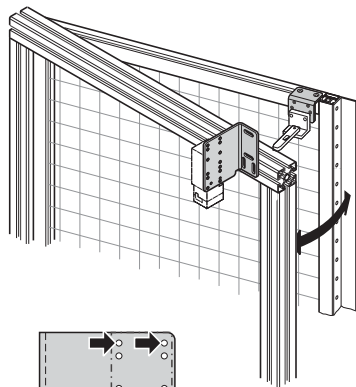
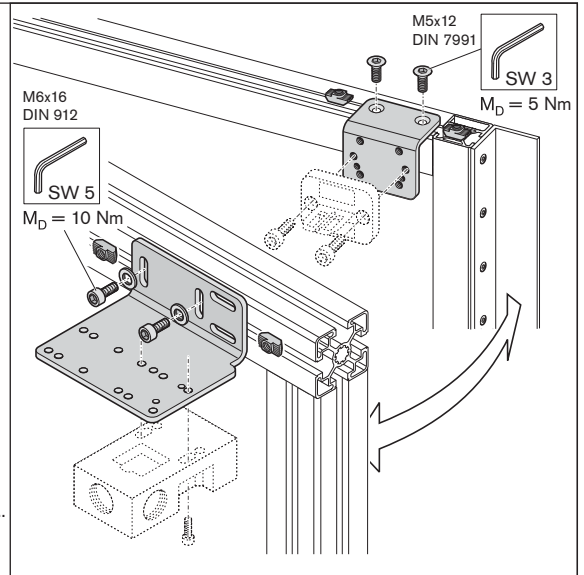

Euchner NZ ... VZ

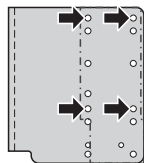

Euchner NZ ... VS

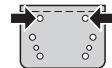

Euchner 02429...

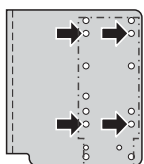
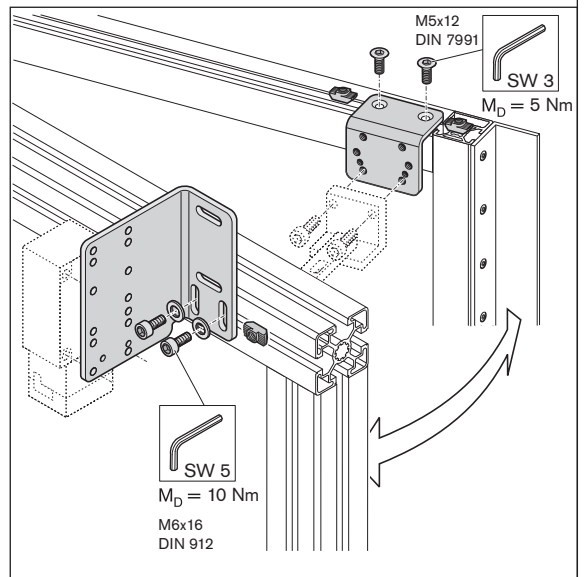

Schneider Electric XCS-A
Schneider Electric XCS-C

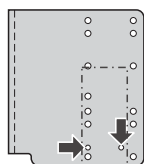

Schneider Electric XCS-PA

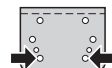

Schneider Electric XCS-Z03

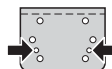

Schneider Electric XCS-Z13

3 842 522 476

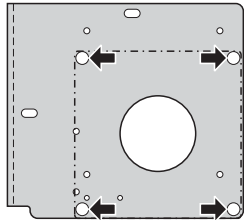
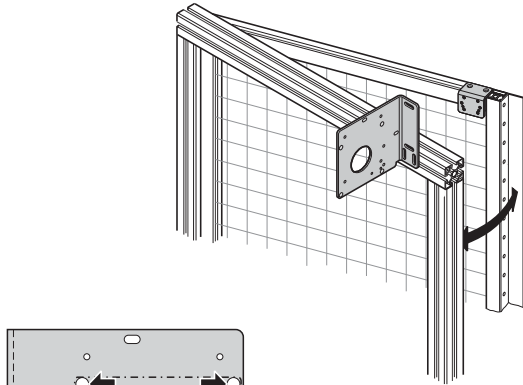

Euchner TZ

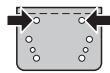

Euchner 02429...

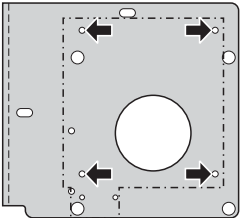

Schneider Electric XCS-E

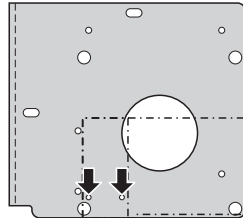
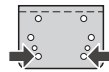
Schneider Electric XCS-TE
(Schneider Electric XCS-PA)

Schneider Electric XCS-Z03

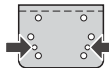

Schneider Electric XCS-Z13

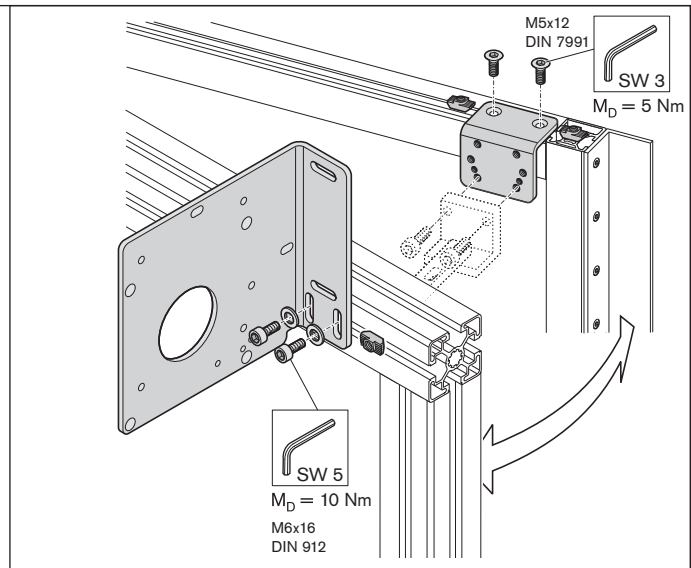

3 842 522 477

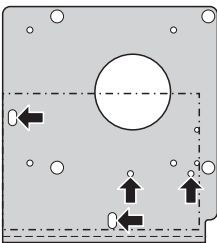
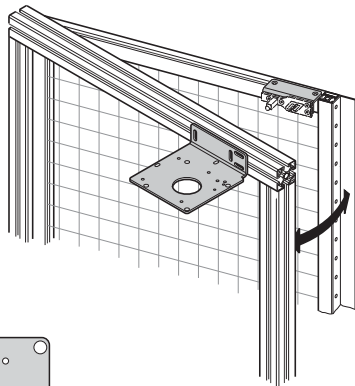

Schmersal AZM 161...

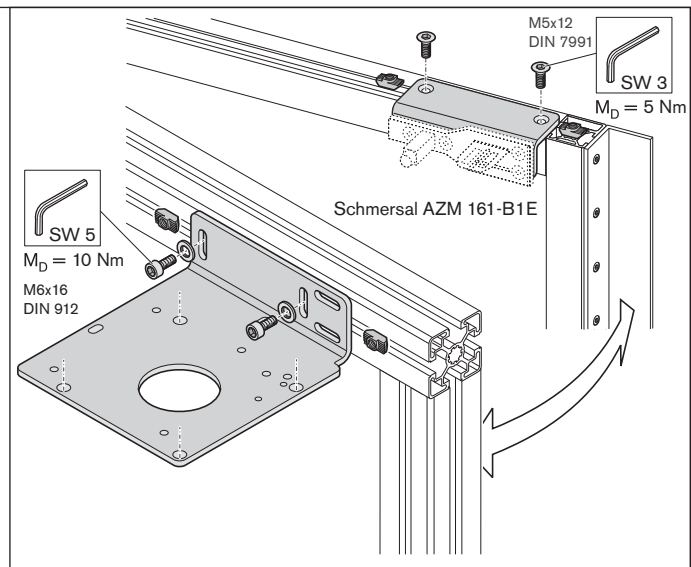

523762-02