

Montagewerkzeug für Kette TS 2/C-H

Chain assembly tool

链安装工具

3 842 546 246/2006-11

Replaces: –
DE+EN+ZH



Montageanleitung • Assembly instructions • 安装说明书

3 842 538 366

Einbaulage Demontage
Disassembly installation position
拆卸时的安装位置

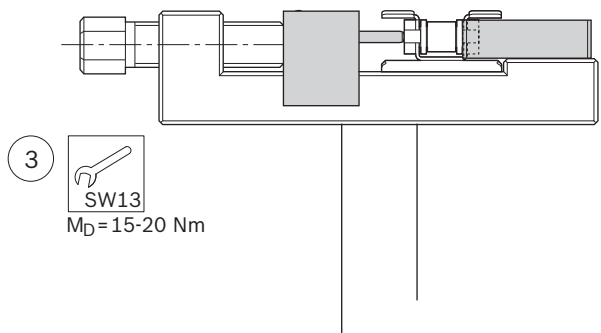
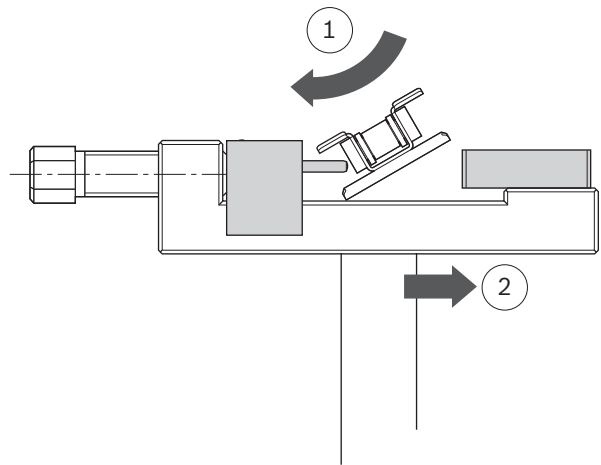
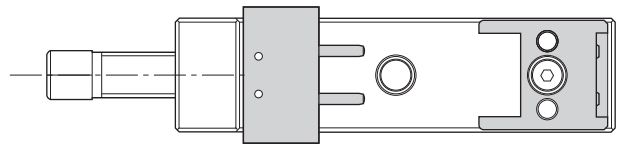
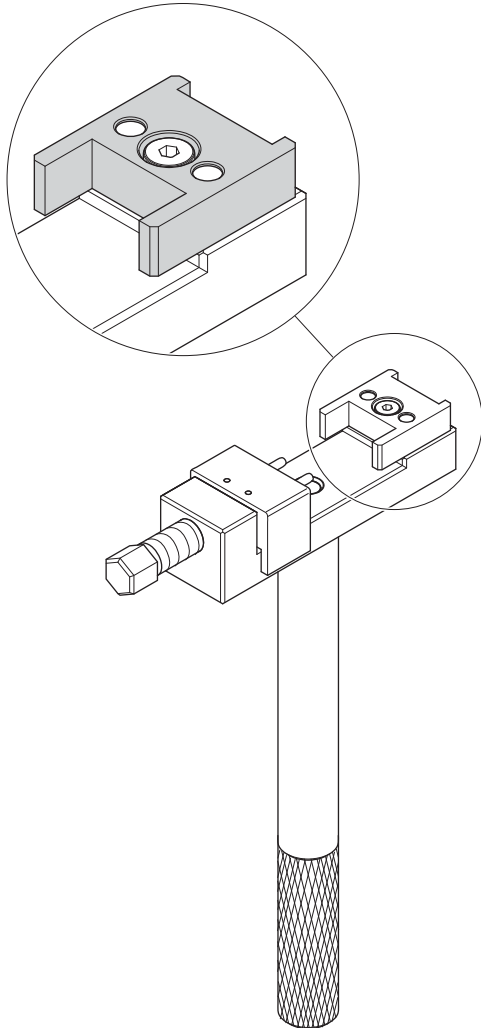

Einbaulage Montage
 Assembly installation position
 安装时的安装位置

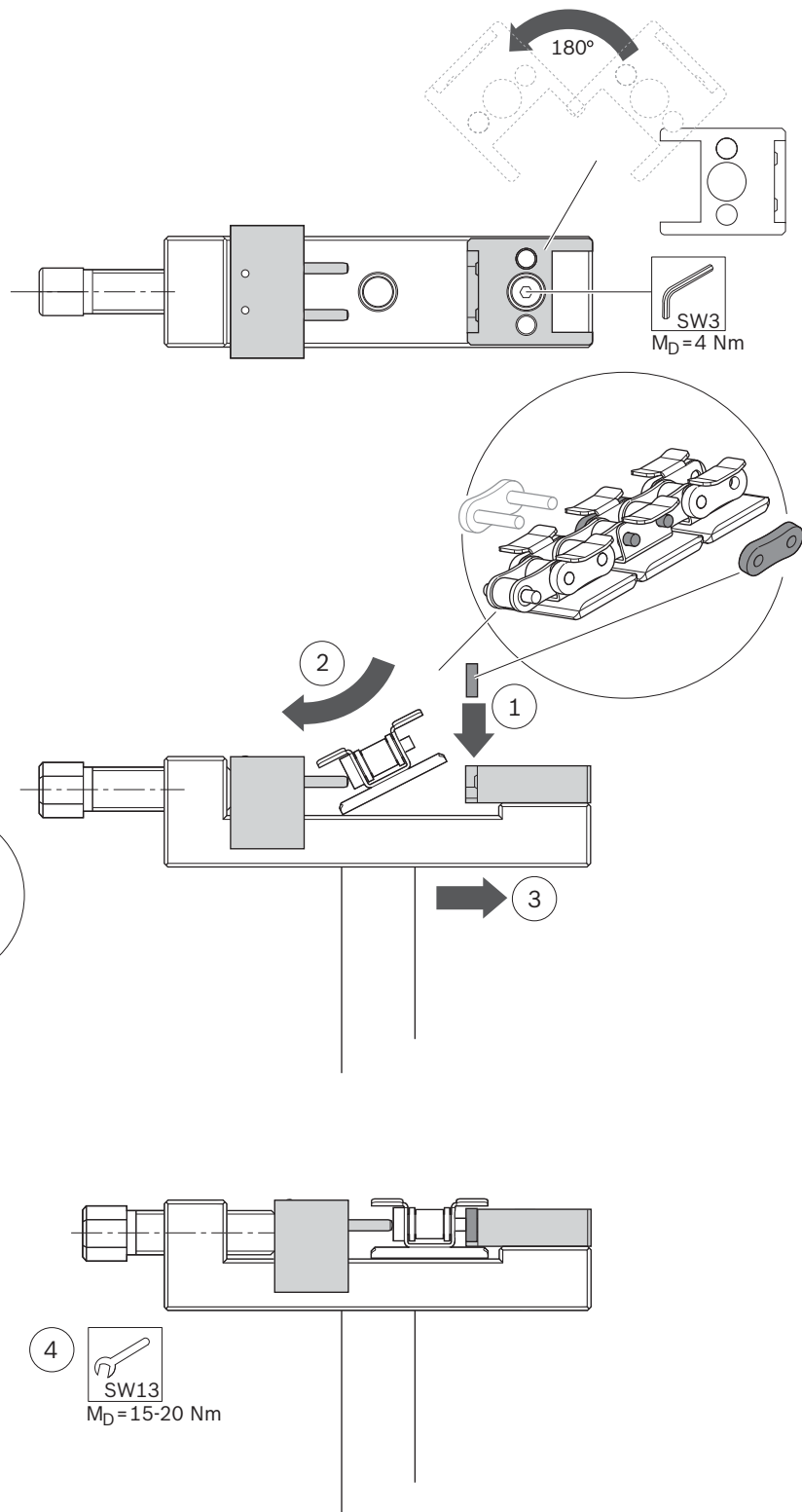
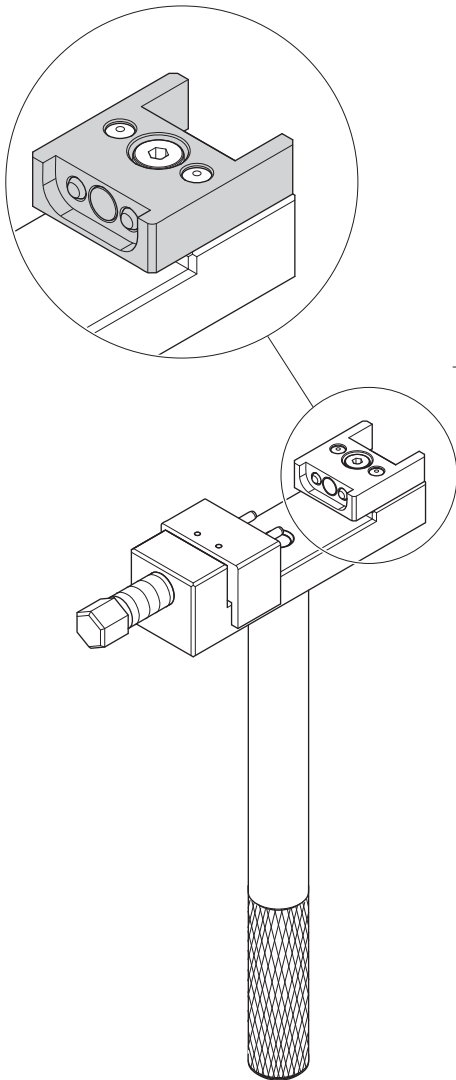

537 150-02