

Schranke VarioFlowplus Flow Control
Barrier VarioFlowplus Flow Control
杆 VarioFlowplus Flow Control
Barriere VarioFlowplus Flow Control
Sbarra VarioFlowplus Flow Control
Barrera VarioFlowplus Flow Control
Barreira VarioFlowplus Flow Control

3 842 553 067/2016-11

Replaces: -

DE+EN+ZH+FR+IT+ES+PT



Montageanleitung • Assembly instructions • 安装说明书 • Instructions de montage
 Istruzioni per il montaggio • Instrucciones de montaje • Instruções de montagem

<p>3 842 553 070</p>	<p>1</p>
	<p>2</p>
	<p>3</p>
	<p>4</p>
	<p>5</p>
	<p>6</p>
	<p>7</p>
	<p>8</p>

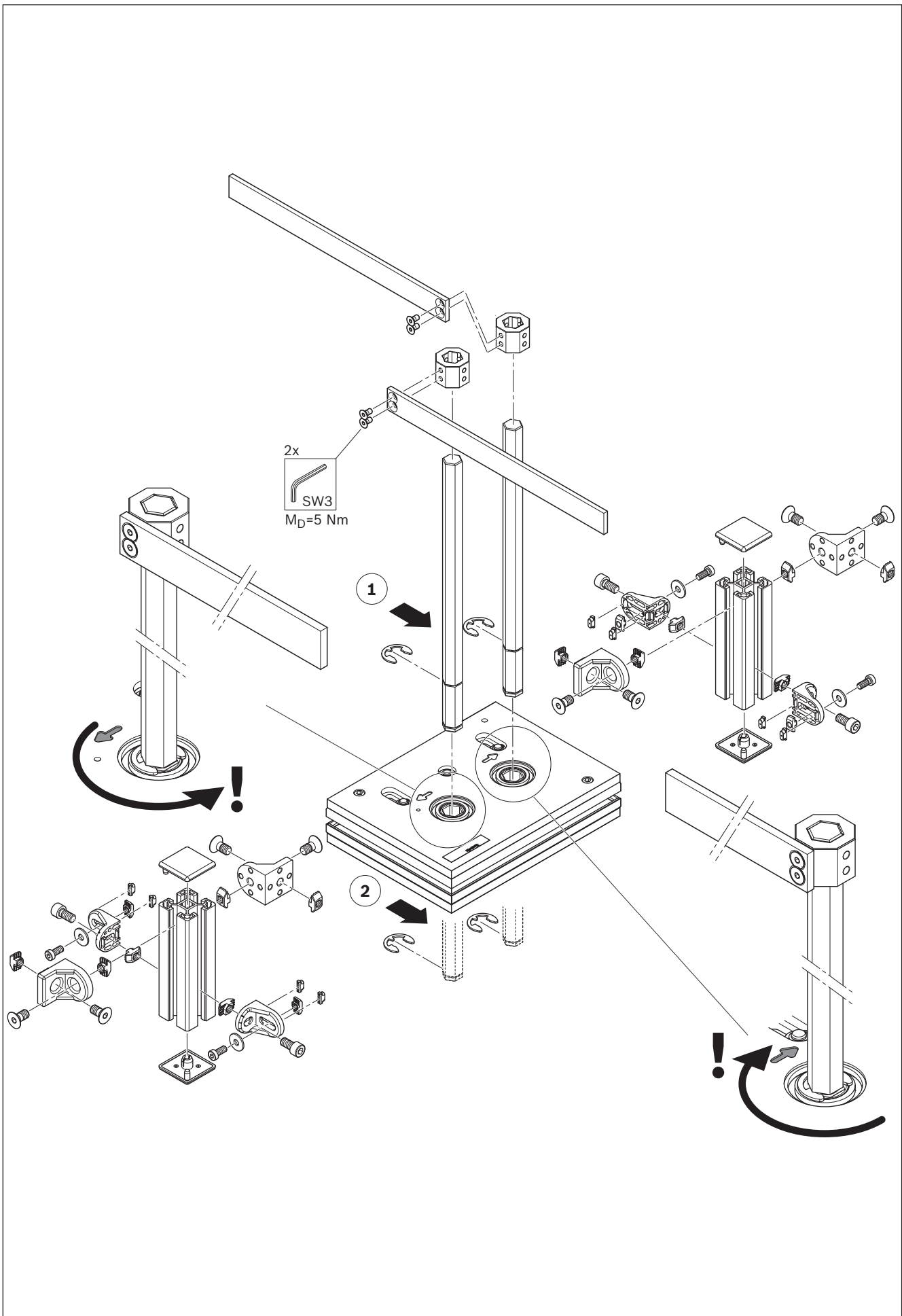

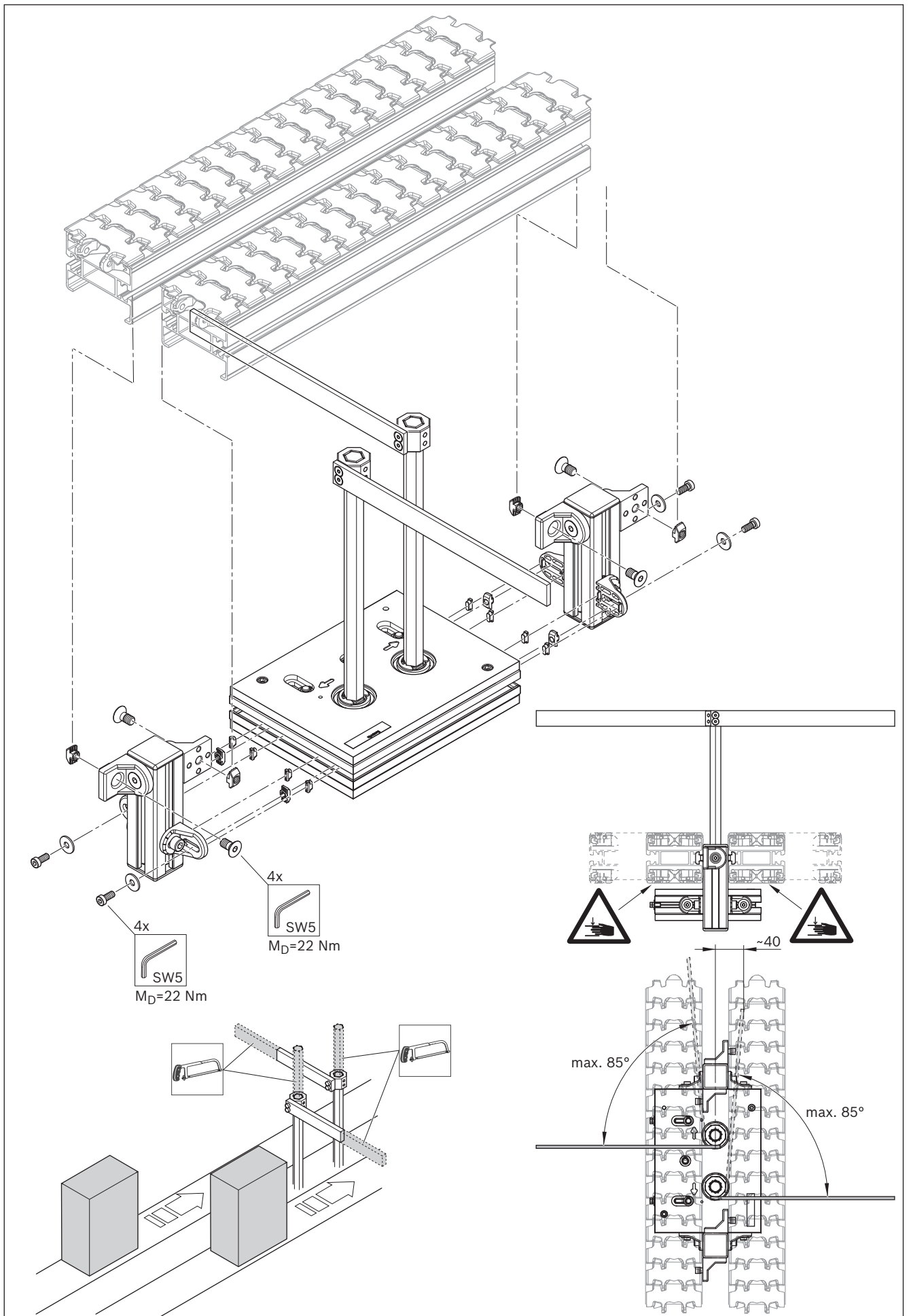

Zulässige Beladung
Permissible load
最大载荷
Charge admissible
Carico ammesso
Carga permitida
Carga admissível

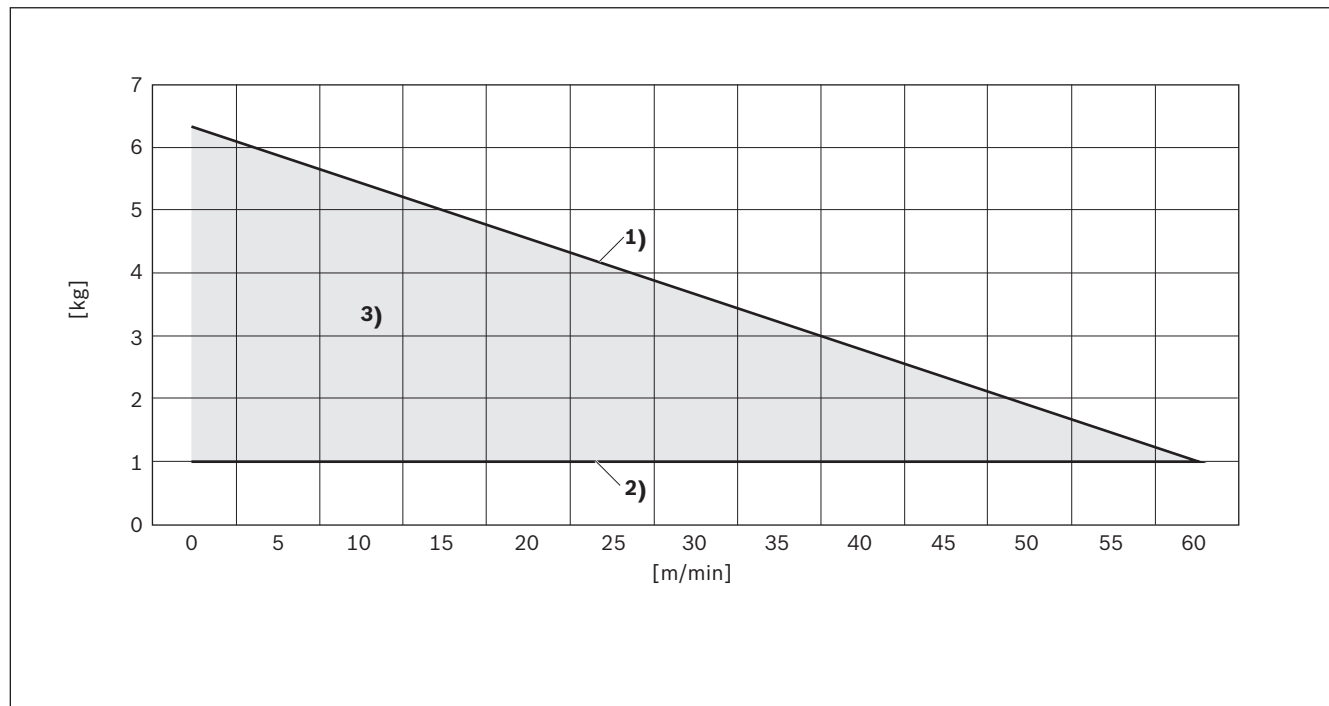

553 067-04

- | | | |
|--------------------------------------------------------------------------------------------------------------------------------------------------------------------------------------------------------|----------------------------------------------------------------------------------------------------------------------------------------------------------------------------------------------------------|-----------------------------------------------------------------------------------------------------------------------------------------------------------------------------------------------------------|
| <p>1) Maximal zulässige Last
 Maximum permissible load
 最大允许的负载
 Charge admissible maximum
 Carico massimo ammesso
 Carga máxima permitida
 Carga máxima admissível</p> | <p>2) Mindestens benötigte Last
 Minimum required load
 最小所许的负载
 Charge nécessaire minimum
 Carico minimo necessario
 Carga mínima necesaria
 Carga mínima necessária</p> | <p>2) zulässiger Lastbereich
 Permissible load range
 允许的负载范围
 Plage de charge admissible
 Area di carico ammessa
 Margen de carga permitido
 Área de carga admissível</p> |
|--------------------------------------------------------------------------------------------------------------------------------------------------------------------------------------------------------|----------------------------------------------------------------------------------------------------------------------------------------------------------------------------------------------------------|-----------------------------------------------------------------------------------------------------------------------------------------------------------------------------------------------------------|