

# Smart Function Kit Handling

R320103224/2022-04

EN

Instructions

EN



\*Dispense-head made by ViscoTec

The information provided serves only as a product description. No statements concerning a certain condition or suitability for a certain purpose can be derived from our information.

The information given does not release the user from the obligation of own judgment and verification. It should be noted that our products are subject to a natural process of aging and wear.

© This document, as well as the data, specifications, and other information set forth in it, are the exclusive property of Bosch Rexroth AG. It may not be reproduced or given to third parties without our consent.

The title page contains an illustration of a sample configuration. The product as delivered can differ from the illustration.

The original instructions are in German.

Any dissemination of the product must include these instructions and the safety instructions for linear motion systems.

Die vorliegende Anleitung ist in folgenden Sprachen verfügbar.  
These operating instructions are available in the following languages.

DE Deutsch (Originaldokumentation)

EN English

**Inhalt**

<b>1 About these instructions</b> . . . . .	<b>4</b>	<b>9 Connection of the HMI terminal device</b> . . . . .	<b>45</b>
1.1 Validity of the documentation . . . . .	4	9.1 Requirements . . . . .	45
1.2 Required and supplementary documentation . . . . .	4	9.2 Direct connection to the Smart Function Kit for Handling . . . . .	45
1.2.1 Safety instructions in this manual . . . . .	5	9.2.1 Setting the IP addresses . . . . .	45
1.2.2 Symbols . . . . .	6	9.3 Connection of a higher-level controller . . . . .	45
1.2.3 Abbreviations . . . . .	6	9.4 Connection to the IT infrastructure . . . . .	46
<b>2 Safety instructions</b> . . . . .	<b>6</b>	<b>10 Commissioning</b> . . . . .	<b>47</b>
<b>3 Scope of delivery</b> . . . . .	<b>7</b>	10.1 Checking the operating conditions . . . . .	47
3.1 Condition as delivered . . . . .	7	10.2 Commissioning (trial run, running in) . . . . .	49
3.2 Accessories . . . . .	7	10.3 Operation . . . . .	49
3.3 Overview of multi-axis systems . . . . .	7	<b>11 Maintenance and care</b> . . . . .	<b>49</b>
<b>4 Product description</b> . . . . .	<b>8</b>	<b>11.1 Maintenance and repair</b> . . . . .	<b>49</b>
4.1 Performance description . . . . .	8	<b>11.2 Lubrication</b> . . . . .	<b>49</b>
4.2 Device description . . . . .	8	<b>12 Disposal</b> . . . . .	<b>50</b>
4.3 Product identification / Technical delivery information . . . . .	10	12.1 Return . . . . .	50
<b>5 Transport</b> . . . . .	<b>11</b>	12.2 Packaging . . . . .	50
<b>6 Assembly</b> . . . . .	<b>11</b>	12.3 Product . . . . .	50
6.1 Assembly of the adapter solution for the dosing system of the ViscoTec RD-EC series . . . . .	11	12.4 Batteries and accumulators . . . . .	50
6.2 Dispense head sensor . . . . .	22	12.5 Recycling . . . . .	50
6.3 Dispenser drive . . . . .	24	<b>13 Service and support</b> . . . . .	<b>51</b>
6.4 I/O modules . . . . .	25	<b>14 Operating conditions</b> . . . . .	<b>51</b>
<b>7 Energy installation</b> . . . . .	<b>27</b>	14.1 Tightening torques . . . . .	52
<b>8 Installation</b> . . . . .	<b>27</b>		
8.1 General installation instructions . . . . .	27		
8.2 Introduction to topologies (controller combinations) . . . . .	28		
8.3 Installation of the drive controllers . . . . .	29		
8.3.1 Description of power units . . . . .	29		
8.3.2 Description of control components . . . . .	31		
8.4 Description of connection terminals . . . . .	31		
8.4.1 Protective conductor . . . . .	31		
8.4.2 XD01, mains connection . . . . .	33		
8.4.3 Intermediate circuit connection XD02 L+ L- . . . . .	34		
8.4.4 XZ03, hybrid connection . . . . .	36		
8.4.5 Motor encoder XG20 (hybrid cable) . . . . .	38		
8.4.6 XG02, Bb relay contact . . . . .	38		
8.4.7 XD10, 24 V supply (control voltage) . . . . .	39		
8.4.8 Communication (EtherCAT slave) (XMD1/XMS1/XF21/P1) . . . . .	40		
8.4.9 XG31, digital inputs and outputs, analog input . . . . .	41		
8.4.10 XG41, safety engineering Safe Torque Off single axis; double axis . . . . .	42		
8.4.11 ctrlX Drive plus with ctrlX CORE . . . . .	43		

# 1 About these instructions

## 1.1 Validity of the documentation

This documentation applies to the following products:

- Smart Function Kit for Handling (SFK4H) according to the "Smart Function Kit Handling" online catalog.

This documentation is intended for assembly personnel, operators and system owners.





















This documentation contains important information for the proper and safe assembly, operation and maintenance of the product and for troubleshooting simple errors oneself.

- ▶ Before commencing any work with the product, be sure to read these instructions, the instructions for multi-axis systems (R320103109) and the "Safety Instructions for linear motion systems" carefully and completely.

## 1.2 Required and supplementary documentation

Documentation which is indicated by the book symbol  must be obtained before handling the product and must be observed:

**Tabelle 1: Required documentation**

	Title	Document number	Document type
	Safety instructions for linear motion systems	R320103152	Safety instructions
	Multi-axis systems	R320103109	Instructions
	Linear modules	R320103169	Instructions
	compact modules	R320103178	Instructions
	Angle bracket X-Y axis	R320103203	Instructions
	Angle bracket X-Z axis	R320103204	Instructions
	Connection plate Y-Z axis	R320103205	Instructions
	Cleated sheet for cable drag chain	R320103206	Instructions
	Lifting a multi-axis system	R320103207	Instructions
	Profile for EFK	R320103216	Instructions
	Multi-axis system	R999001307	Data sheet
	Smart Function Kit for Handling	R320103217	Instructions
	Smart Function Kit for Handling	R320103218	Software instructions
	Indra Drive X	R911392531	Operating instructions
	CtrlX controllers	R911405646	Operating instructions
	ctrlX Drive	R911386578	Description of the project planning
	ctrlX DRIVEplus with ctrlX CORE	R911403315	Quick start guide
	IT security guidelines	R911342561	Instructions
	Safety and warning notice on control components	R911171137	Safety instructions
	Motor MS2N	R911340694	Safety instructions
	Motor MS2N synchronous servo motors	R911347580	Operating instructions



The Rexroth documentation is available for download at [www.boschrexroth.com/mediadirectory](http://www.boschrexroth.com/mediadirectory).

<https://www.boschrexroth.com/en/xc/myrexroth/mediadirectory?publication=NET&WT.ac=Produktdokumentation>

## Presentation of information

To enable users to work rapidly and safely with the product while following these instructions, this documentation uses standardized safety instructions, symbols, terms and definitions, and abbreviations. These are explained in the following sections.

### 1.2.1 Safety instructions in this manual

This document contains safety instructions preceding any actions that involve a risk of personal injury or damage to property. The safety precautions described must be adhered to.



Safety instructions are structured as follows:

 <b>SIGNAL WORD</b>
<b>Type of hazard!</b> Consequences if ignored. ► Hazard prevention measure.

- Warning sign: draws attention to the hazard
- Signal word: indicates the severity of the hazard
- Type of hazard: indicates the type or source of hazard
- Consequences: describes the consequences that may occur if precautions to avoid the hazard are not taken
- Hazard prevention measure: indicates how to avoid the hazard

The safety instructions cover the following hazard classes. The hazard class describes the risks involved if the safety instruction is not complied with.







**Tabelle 2: Hazard classes as per ANSI Z535**

Warning sign, signal word	Meaning
 <b>DANGER</b>	Indicates a hazardous situation which will result in death or serious injury if not avoided.
 <b>WARNING</b>	Indicates a hazardous situation which may result in death or serious injury if not avoided.
 <b>CAUTION</b>	Indicates a hazardous situation which may result in minor or moderate injury if not avoided.
<b>NOTICE</b>	Property damage: The product or surroundings may be damaged

## 1.2.2 Symbols

The following symbols indicate notes which are not related to safety but make the documentation easier to understand.

**Tabelle 3: Meaning of the symbols**

Symbol	Meaning
	If this information is not observed, the product will not be optimally used / operated.
	Single, independent work step
1. 2. 3.	Numbered work steps The numbers indicate the sequence of the work steps.
	see (general reference)
	see section 7
 Fig. 7.1	see figure 7.1
	Screw with strength class...
	Tightening torque
$\mu$	Friction factor for screws

## 1.2.3 Abbreviations

The following abbreviations are used in this documentation:

**Tabelle 4: Abbreviations and definitions**

Abbreviation	Meaning
SFK4H	Smart Function Kit for Handling
CtrlX Ddrive	Drive controller
ctrlX Core	Drive controller incl. controller (CORE) integrated in the drive controller
HMI	Human Machine Interface (graphical user interface)

# 2 Safety instructions

The general safety instructions for this product can be found in the documentation "Safety instructions for linear motion systems". You must have read and understood these before handling the product.

### 3 Scope of delivery

Scope of delivery depending on the order.

- ▶ Smart Function Kit for Handling (multi-axis system), cable management and motor cable (optional), motors, ctrlX drive controller, ctrlX Core integrated control, and accessories (variable, depending on the configuration)
- ▶ Preinstalled software package (includes the following APPs, see table... Depending on the order, there are standard apps that are always included in the scope of delivery or can be ordered optionally)

**Tabelle 5: Scope of delivery**

APP	Scope of delivery	Optional
SFK handling	●	
Automation	●	
Cartesian Motion	●	
EtherCAT	●	
Safety STO	●	
OPC-UA	●	
ReST	●	
Pyton	●	
IDE	●	
PLC		●
VPN		●
Firewall		●
IOT Gateway		●
User APP		●
Node-RED		●
Remote Agent		●

EN

#### 3.1 Condition as delivered

Depending on the configuration

#### 3.2 Accessories

- Mechanical interfaces (Z-axis adapter) and clamping fixtures for fastening to the basic axis
- Connection cable
- I/O modules
- Connecting shaft

#### 3.3 Overview of multi-axis systems

- ▶ For an overview of types, see the instructions for multi-axis systems R320103109

## 4 Product description

### 4.1 Performance description

The technical data depend on the configuration and are included in the technical delivery information.

### 4.2 Device description

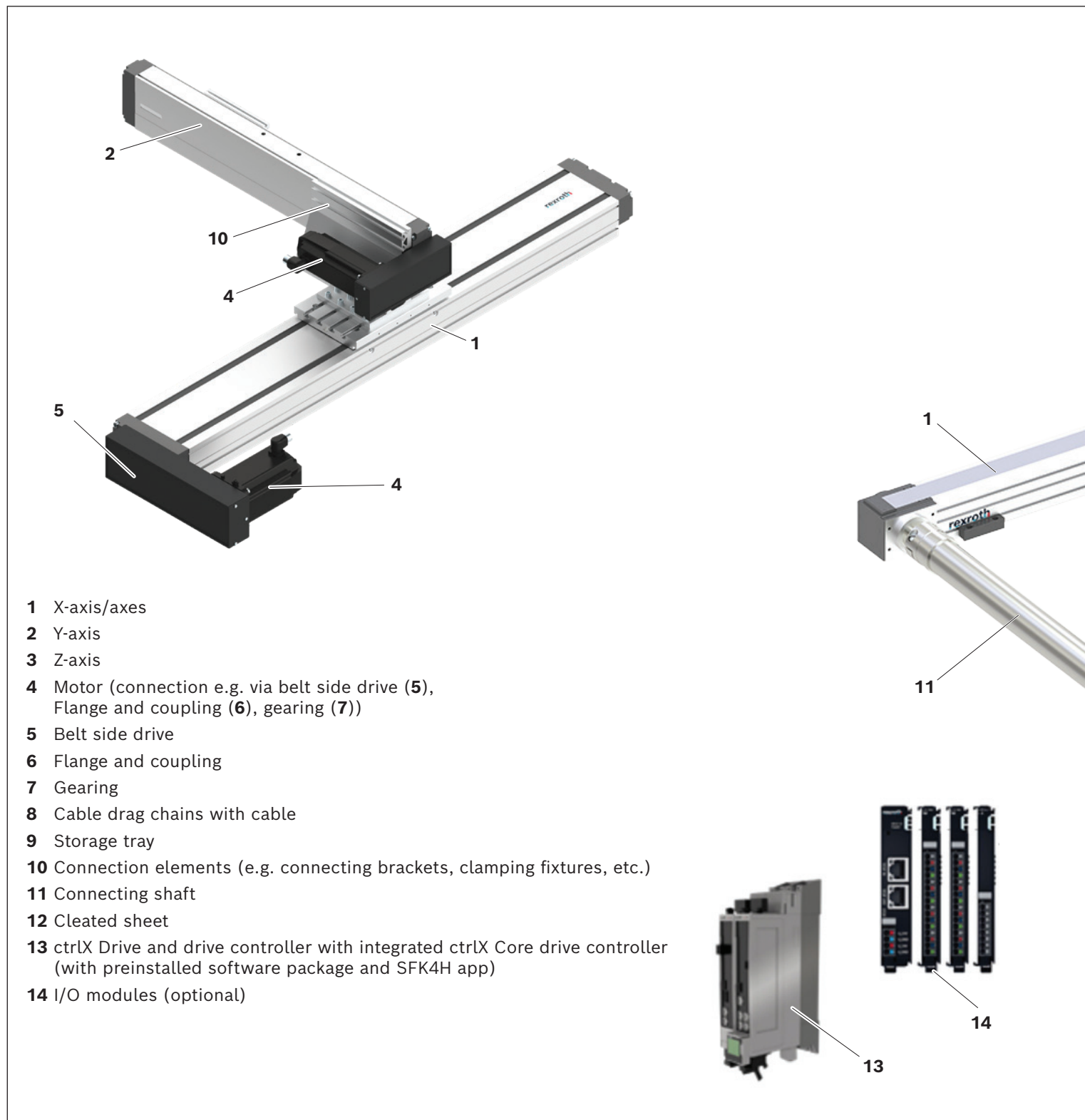
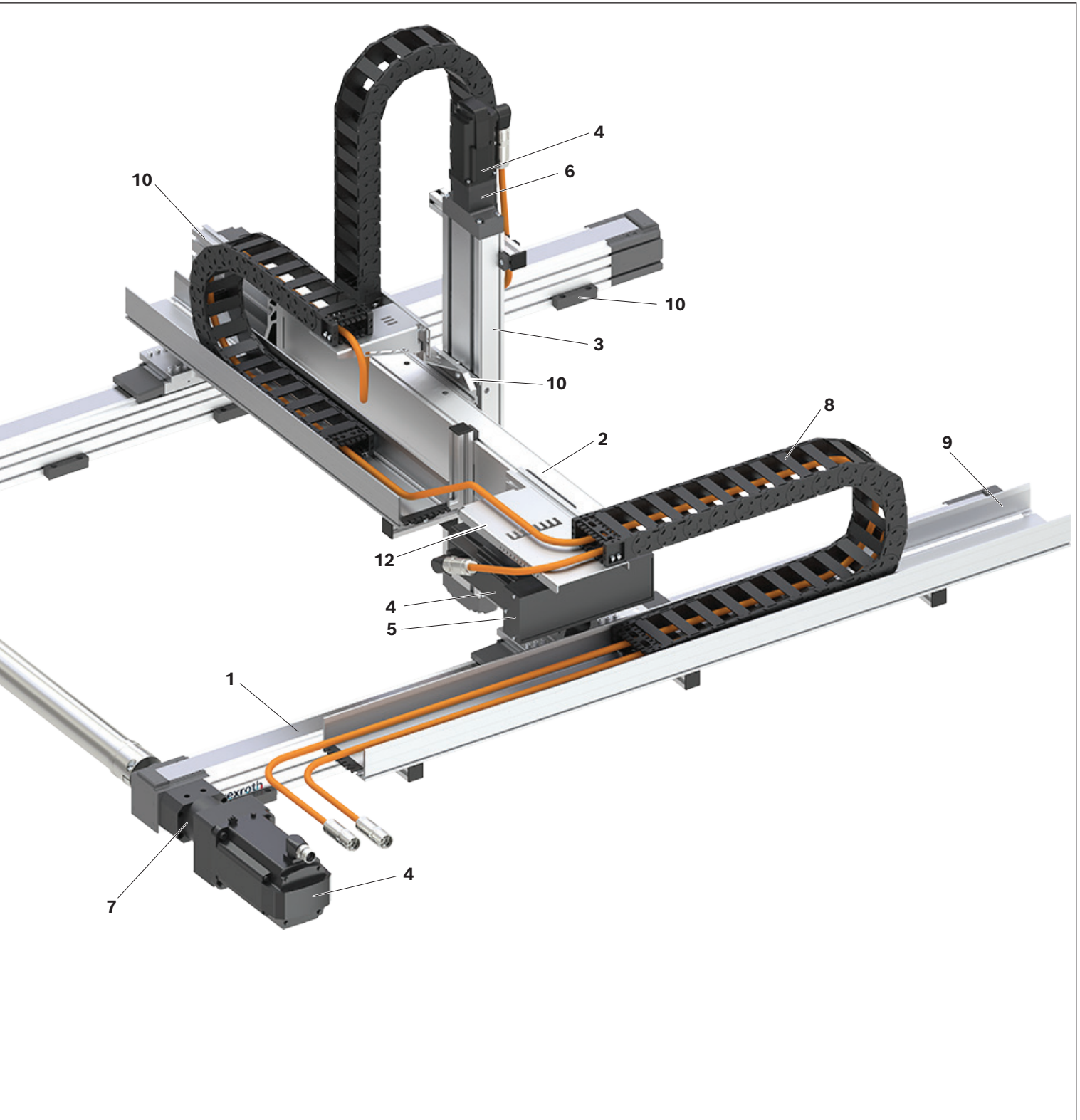



Fig. 1: Components of a multi-axis system (examples)



### 4.3 Product identification / Technical delivery information

<b>rexroth</b>  CNR: R12345678 TYP: CMS-3SB-30-2 CS: 9876543210 0030 0001		Bosch Rexroth AG D-97419 Schweinfurt Made in Germany  MNR: R987654321 FD: 5129 <span style="border: 1px solid black; border-radius: 50%; padding: 2px;">7210</span>		
$s_{max}$ (mm)	$u$ (mm/U)	$v_{max}$ (m/s)	$a_{max}$ (m/s <sup>2</sup> )	
--	--	--	--	--

CNR	Customer's material number
MNR	Material number
TYP	Short product name
CS	Customer information
FD	Date of manufacture
7210	Manufacturing location
$s_{max}$	Maximum travel range
$u$	Feed constant without motor attachment
$v_{max}$	Maximum travel speed
$a_{max}$	Maximum acceleration rate

$d$  Direction of motor rotation to move in positive (+) direction  
 CW = clockwise  
 CCW = counterclockwise

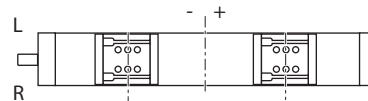
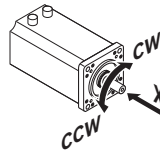

$i$  Gear ratio

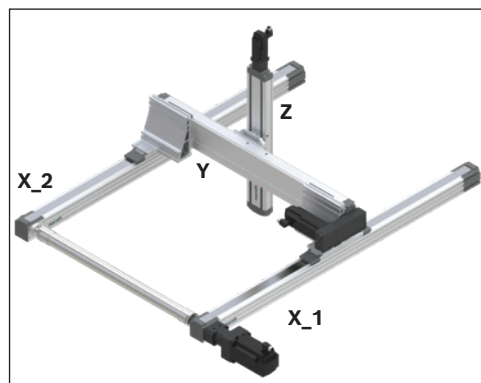

Axis	$s_{max}$ (mm)	$u$ (mm/U)	$v_{max}$ (m/s)	$a_{max}$ (m/s <sup>2</sup> )	$M1_{max}$ (Nm)	$d$	$i$
X_1	2000	205.0	4.78	15.00	7.35	CCW	5
X_2	2000	205.0	5.00	15.00	36.00	CCW	1
Y	1000	10.0	0.52	15.00	8.22	CCW	1
Z	500	10.0	0.77	15.00	13.51	CW	1

The values given describe the mechanical limit values of the axis

Fig. 2: Product identification / Technical delivery information

## 5 Transport

### WARNING

#### **Risk of product falling due to inadequate load handling equipment!**

Death or severe injury.

- ▶ Use only inspected and suitable load handling equipment. Observe the weight ➡ Packaging!
- ▶ Observe the center of gravity
- ▶ Do not stand under suspended loads.



Transport locks and fastenings in the packaging prevent movements of the product during transport

- ▶ Hoist the product using suitable lifting accessories. Fasten lifting accessories carefully at the designated points only. Observe the instructions R320103109 and R320103207.

EN

## 6 Assembly

### WARNING

#### **Uncontrolled movements due to lack of self-locking of the product/carriage after removal of the transport locks!**

Death or severe injury.

- ▶ Secure the product/carriage against dropping.
- ▶ Do not stand in the fall direction.

- ▶ For assembly, installation conditions and preparatory assembly activities, please refer to the corresponding chapter in the instructions R320103109

### 6.1 Assembly of the adapter solution for the dosing system of the ViscoTec RD-EC series

The scope of delivery of the adapter solution varies depending on the design type of the configured multi-axis system.

The type of construction of the system can be found on the nameplate or in the technical delivery information of the product. The format is CMS-XXX-XX-X. According to the nomenclature, the first X determines the number of coordinate axes of the multi-axis system.

#### **Safety note:**

Due to the high dynamics of the multi-axis system, periodic oscillations or vibrations can occur in some processes. Because of this stress, it is imperative that all fasteners associated with the adapter are secured, for example to DIN267-27. With the included fasteners, this is present everywhere. The note must be observed particularly when the customer makes changes to the adapter solution.

There are two basic types of adapter solution, the assembly of which differs, and each associated with a group of construction types.

The assembly of the two types is described below..

**Type 1:**

Valid for these construction types:

3SA-20, 3SA-21, 3SA-22, 3SA-23, 3SA-30, 3SA-31, 3SB-20, 3SB-21, 3SB-22, 3SB-23, 3SB-30, 3SB-31, 3SB-40, 3SB-41, 3SC-22, 3SC-23, 3SC-30, 3SC-31, 3SC-40, 3SC-41, 2VA-20, 2VA-21, 2VA-22, 2VA-23, 2VA-30, 2VA-31, 2VA-32, 2VA-33, 2VB-20, 2VB-21, 2VB-22, 2VB-23, 2VB-30, 2VB-31, 2VB-32, 2VB-33, 2VB-40, 2VB-41

The scope of delivery consists of an angle (1), a plate (2) and mounting material.

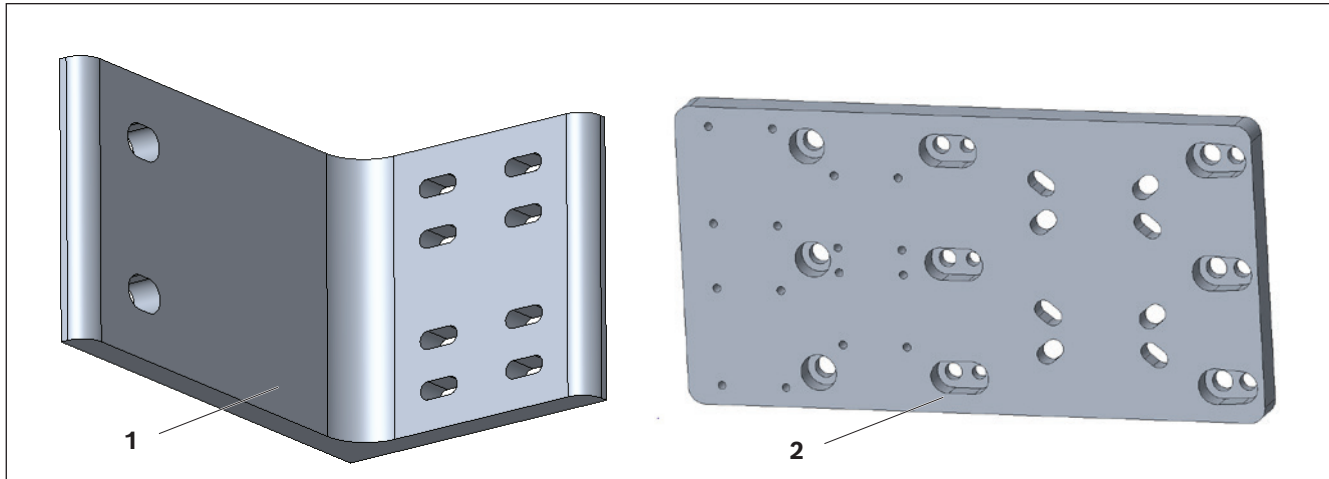

Fig. 3: Type 1 Scope of delivery

Each adapter solution can be installed mirrored, so that the interfering contour of the cartridge and the pre-pressure monitoring of the dosing system can be positioned both to the left and to the right of the z-axis. The picture below shows an example of the installation situations left or right with an indicated dosing system (3).

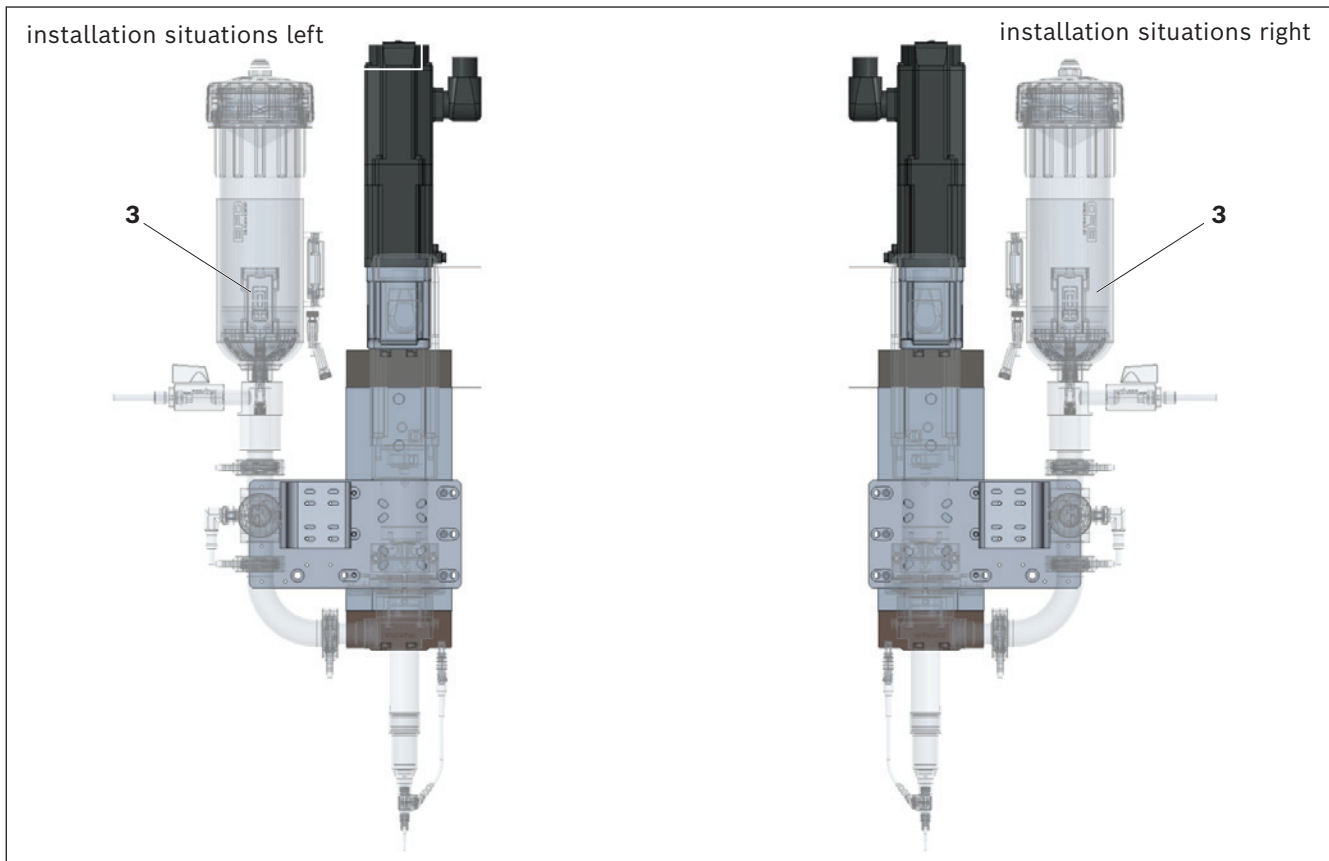

Fig. 4: Type 1 Installation situation dispenser adapter

**Assembly steps:**

The graphics for illustration below also show the mirrored installation situations.

1. Turn the plate on its back
2. Insert the two **centering pieces** into the holes provided. Depending on the size of the z-axis, different holes are correct. The size of the z-axis can be found on the type plate. See the graphic below for this.

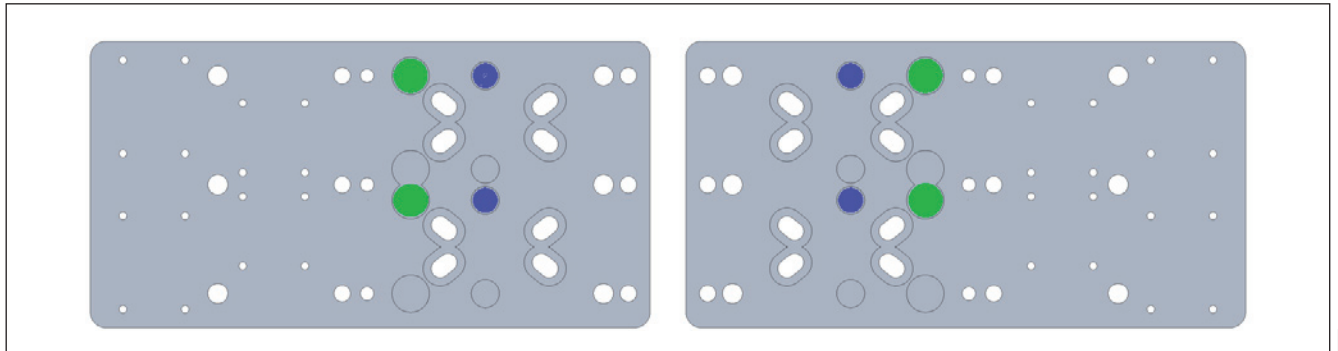

Fig. 5: **Type 1: insert centering pieces**

**CKK-090, CKK-110**

**CKK-145**

3. Mount the flange of the dosing system with 4x DIN6912 M5x16 screws and 4x DIN125 5.3x10x1 washers on the plate from behind. Depending on the mounting orientation selected left or right, the lower hole pattern must be used. The size of the dosing system defines whether the inner (3RD3-EC, 3RD4-EC) or outer ends (4RD6-EC, 3RD8-EC, 3RD10-EC, 3RD12-EC, 2RD12-3D-EC) of the elongated holes are required.

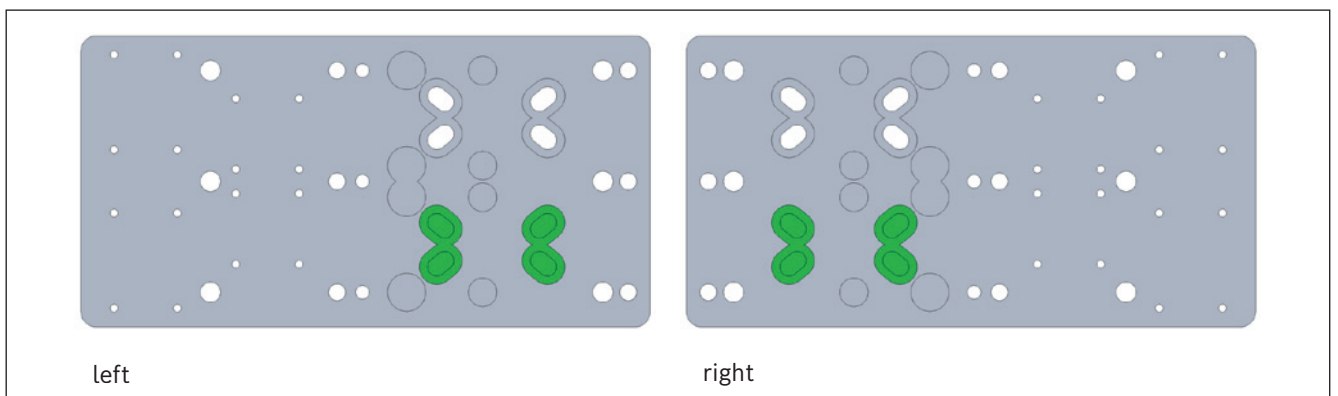

Fig. 6: **Type 1: Mount the dosing system on the plate**

4. Mount the angle (1) to the front of the plate using 4x ISO4762 M3x12 screws and 4x DIN125 3.2x7x0.5 washers. There are two hole patterns in the plate for attaching the angle. The inner hole pattern is for the smaller curvature diameter (**D = 20 cm**) of the pipe for monitoring the inlet pressure and the outer one for larger ones (**D = 25 cm**).

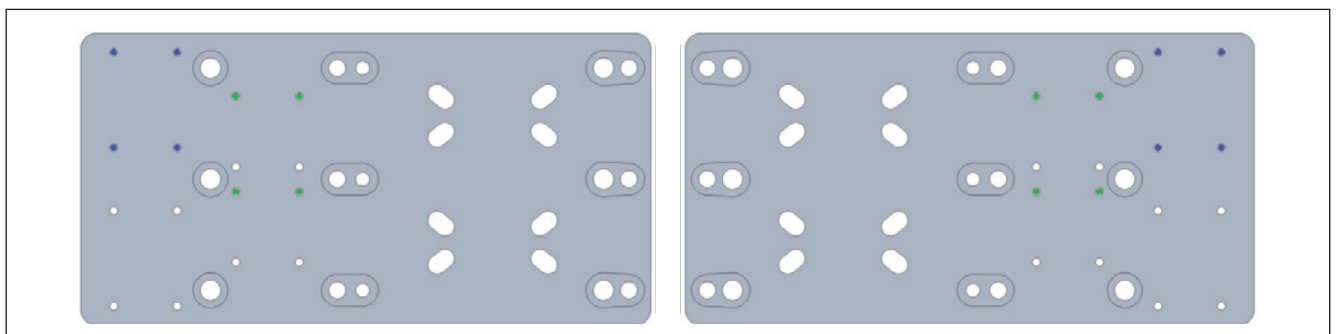

Fig. 7: **Type 1: Mount the angle to the front of the plate**

There are 8 elongated holes in the lower leg of the angle, 4 of which are required for **large dosing head sizes** or **normal dosing head sizes**.

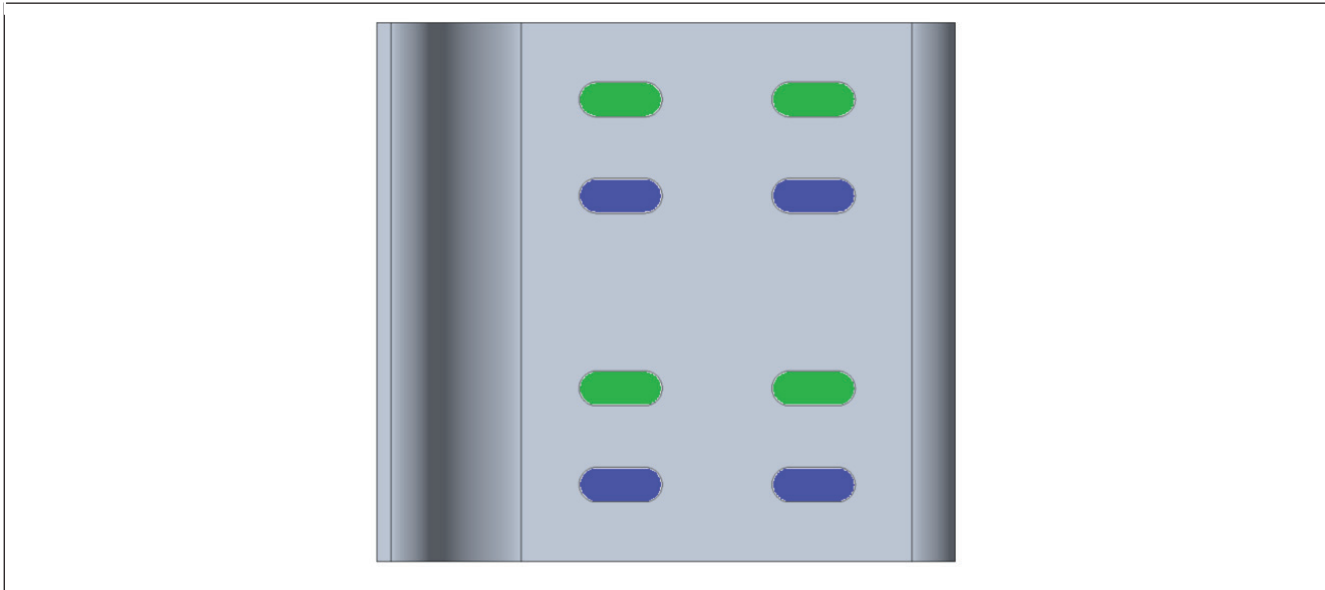

Fig. 8: **Type 1: mounting angle**

The large dosing head sizes include the 3RD12-ED and the 2RD12-3D-EC. The other heads of the RD-EC series belong to the normal-sized hole pattern.

5. Now the pre-pressure monitor can be screwed to the two elongated holes in the left leg of the bracket using 2x ISO 4762 M6x50, 2x DIN 934 M6 and 2x DIN 125 6.4x12x1.6 each.
6. Finally, the plate is attached to the multi-axis system together with the bracket and dosing system. Depending on the size of the z-axis of the existing multi-axis system, other holes are used for this. The assignment of the holes to the axes **CKK-090**, **CKK-110** und **CKK-145** ► Fig 9.

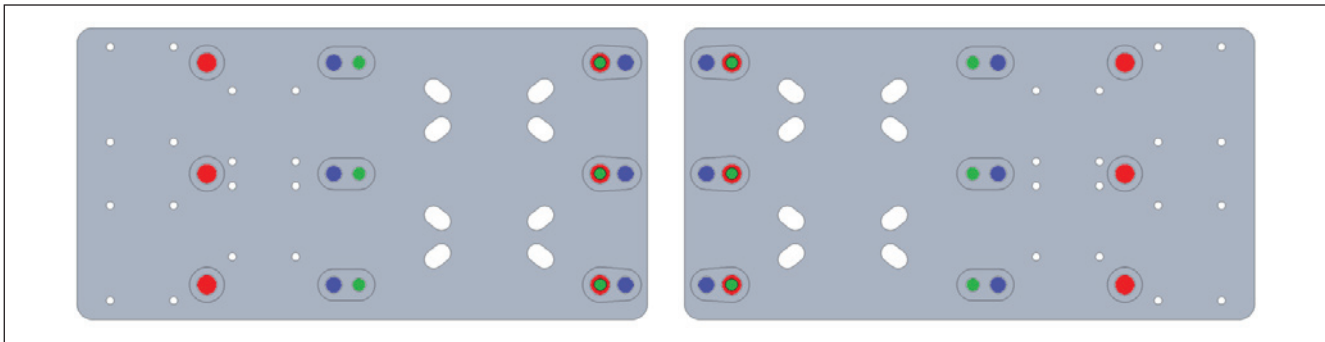

Fig. 9: **Typ 1 Befestigung an CKK**

The **CKK-090** requires **6x DIN 6912 M4x14** and **4x DIN 125 4,3x9x0.8**.

The **CKK-110** requires **6x DIN 6912 M5x12** and the **CKK-145** **6x DIN 6912 M6x12**.

The latter two do not require washers.

**Type 2:**

Valid for these construction types: :

3SA-10, 3SA-11, 3SB-50, 3SB-61, 2HA-08, 2HA-09, 2HA-10, 2HA-11, 2HA-20, 2HA-21, 2HA-22, 2HA-23, 2HA-30, 2HA-31, 2HA-32, 2HA-33, 2HB-20, 2HB-21, 2HB-30, 2HB-31, 2HB-40, 2HB-41, 2HB-50, 2HB-61, 2VB-10, 2VB-11

The scope of delivery consists of an angle (1), a plate (2) a plate (3) and mounting material.

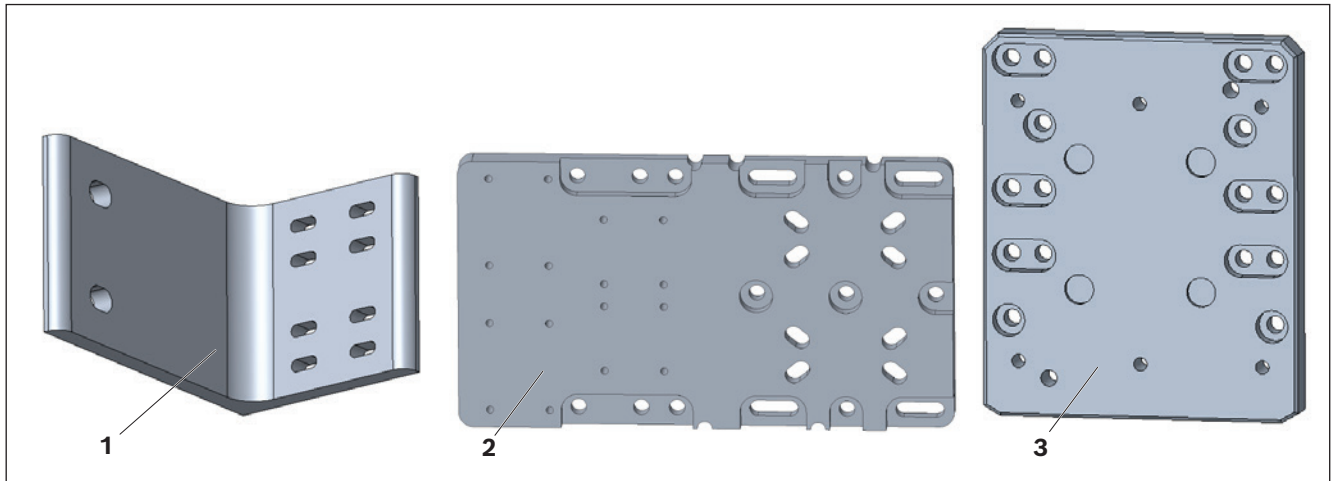

Fig. 10: **Type 1** Scope of delivery

Each adapter solution can be installed mirrored, so that the interfering contour of the cartridge and the pre-pressure monitoring of the dosing system can be positioned both to the left and to the right of the z-axis. The picture below shows an example of the installation situations left or right with an indicated dosing system (3).

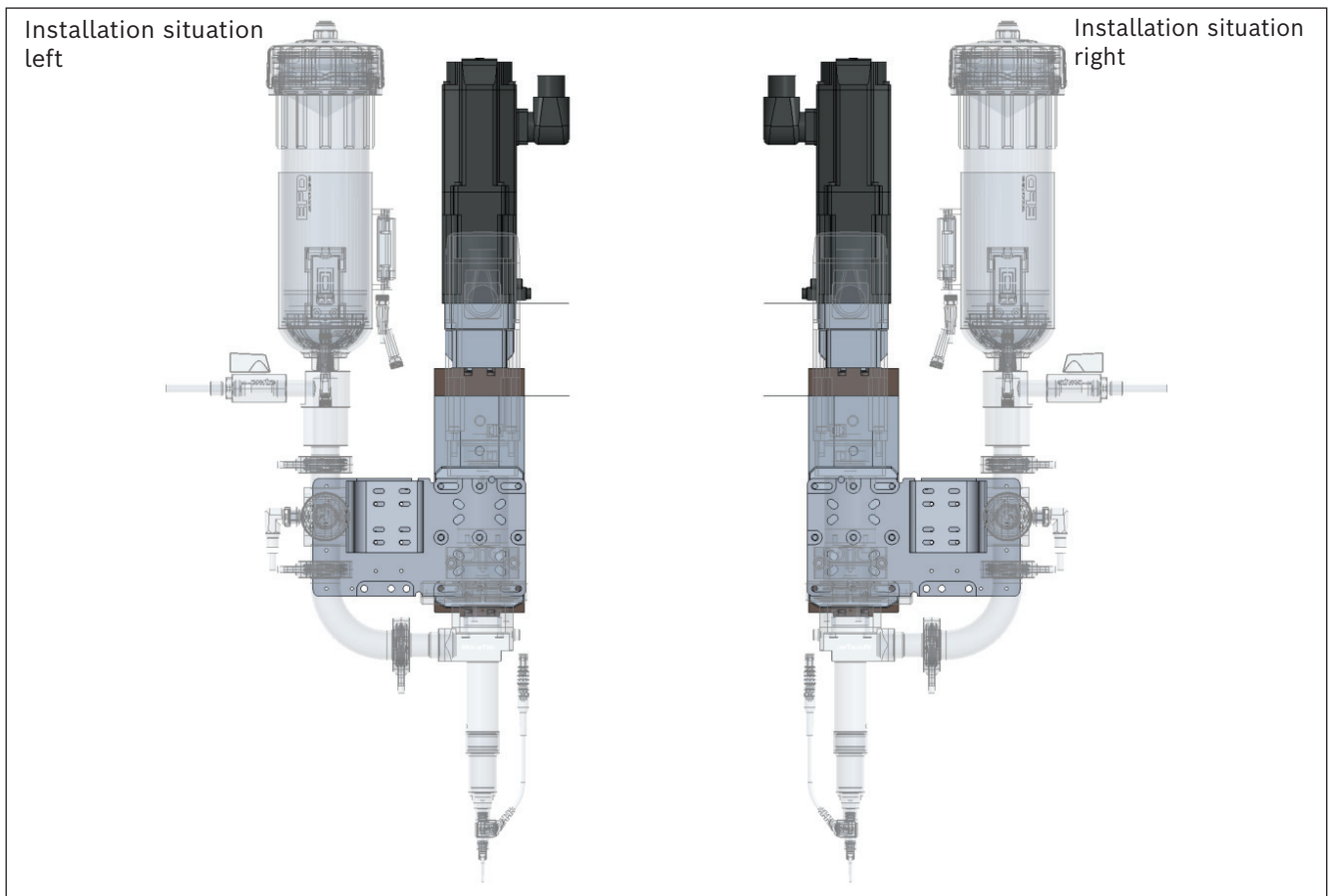

Fig. 11: **Typ 2** Installation situation dispenser

Difference to type 1:

In this type, plate 2 is first attached to the last axis of the multi-axis system (either the y-axis or the z-axis). There are 5 different sizes of plate 2, matching the sizes of the axles. Plate 1 is then mounted on plate 2. There is only one variant of this, so it is the same in every constellation. As with type 1, this includes the bracket and finally the dosing system.

**Assembly steps:**

The graphics for illustration below also show the mirrored installation situations.

1. Turn plate 3 over.
2. Insert the two centering pieces in the holes provided. Depending on the size of the last axis and thus also the size of the plate 3, different holes are correct. See plate 3 in the graphic below.

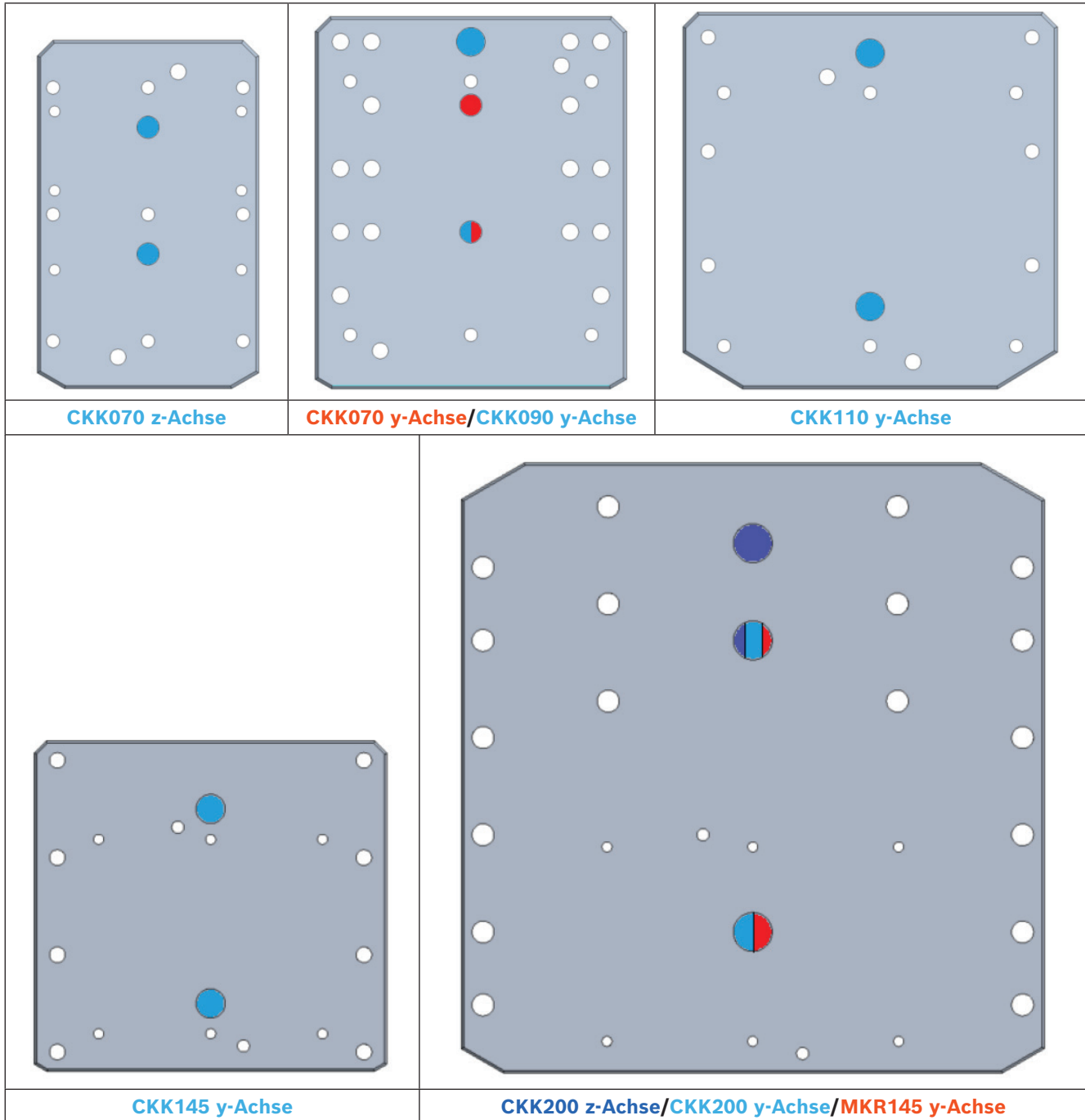

Fig. 12: Type 2 plate 3

3. Turn plate 3 to the front. Insert the two dowel pins ISO8734 5x20 into the corresponding dowel holes on the plate 3 so that the dowel pins are flush with the back of the plate 3.

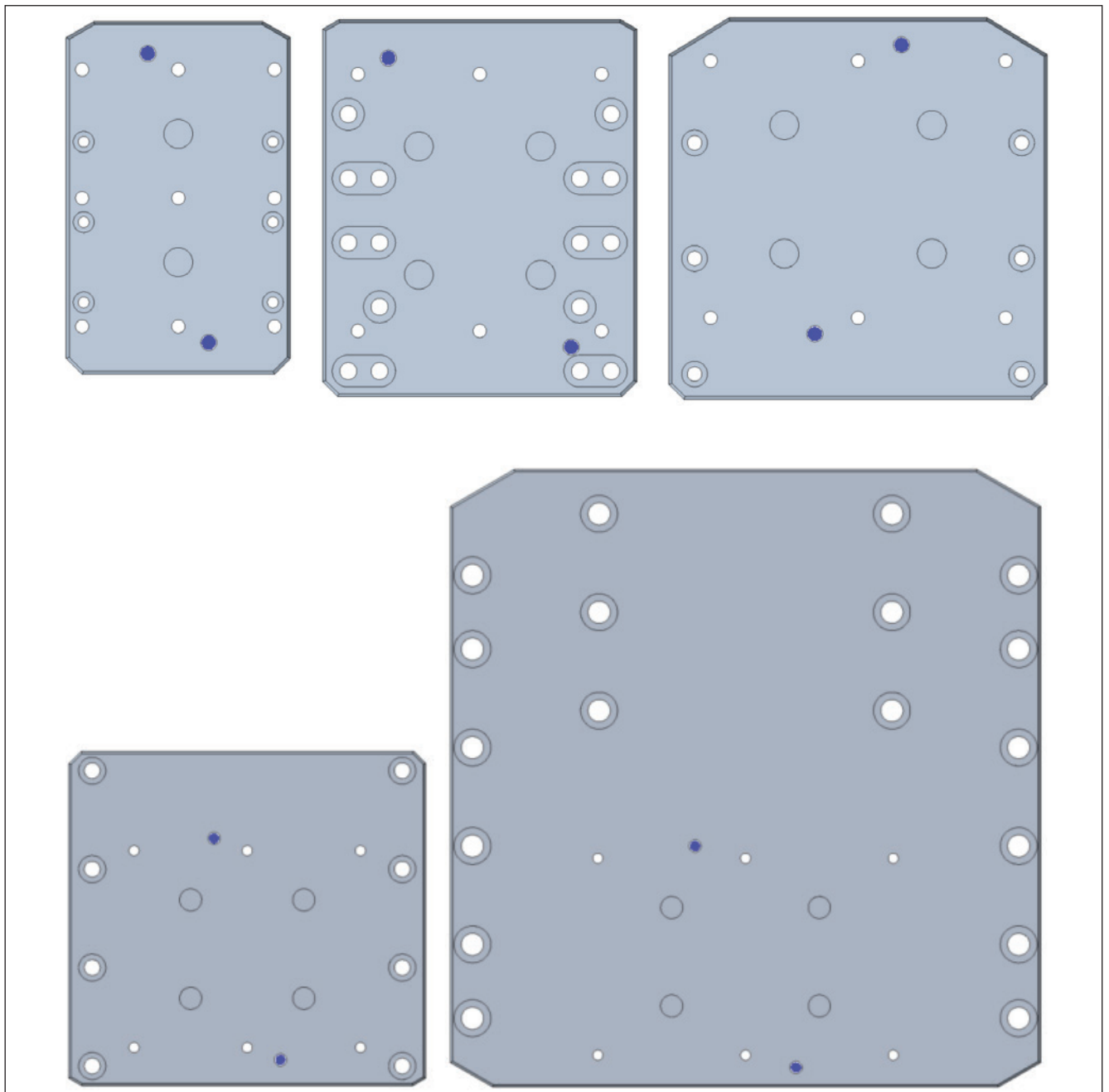

Fig. 13: Type 2 plate 3 dowel pins

4. Turn the plate 3 to the front. If the last axis of your multi-axis system is a z-axis, the plate 3 is now aligned with the centering pieces on the centering holes of the axis main body and mounted.

If the last axis of your multi-axis system is a y-axis, the plate 3 is now aligned with the centering pieces on the composite plate on the table part of the y-axis and mounted. Which holes and screws are to be used for which size of the plate 3 ➔ Fig. 14.

		
<p><b>CKK070 z-axis</b> 6x ISO4762 M3x14</p>	<p><b>CKK070 y-axis/CKK090 y-axis</b> 8x ISO4762 M5x16/8x ISO4762 M5x16</p>	<p><b>CKK110 y-axis</b> 6x ISO4762 M4x16</p>
		
<p><b>CKK145 y-axis</b> 8x ISO4762 M6x12</p>	<p><b>CKK200 z-axis/CKK200 y-axis/MKR145 y-axis</b> 6x ISO4762 M8x16/8x ISO4762 M8x20/8x ISO4762 M8x20</p>	

Fig. 14: Type 2 mounting plate 3

5. Insert the two centering pieces in the holes provided in plate 2 → Fig. 15.

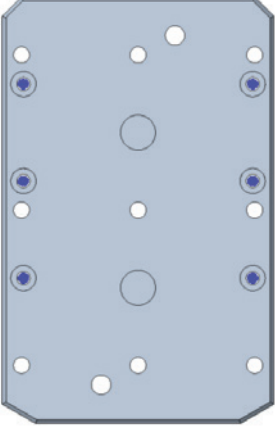
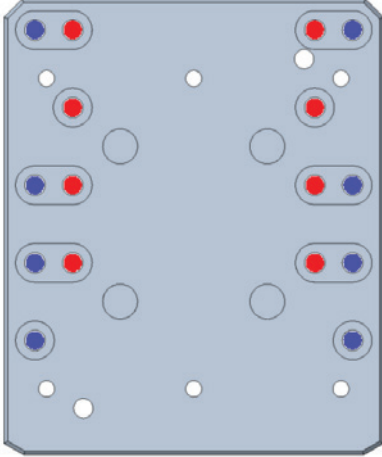
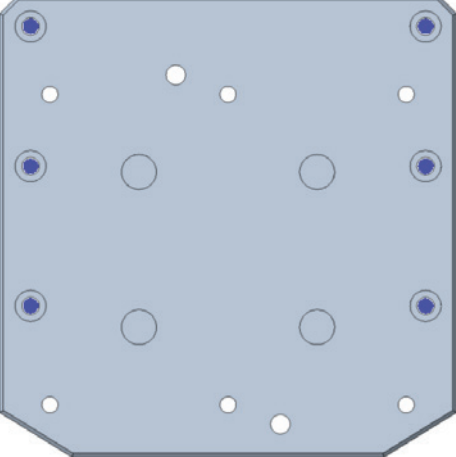
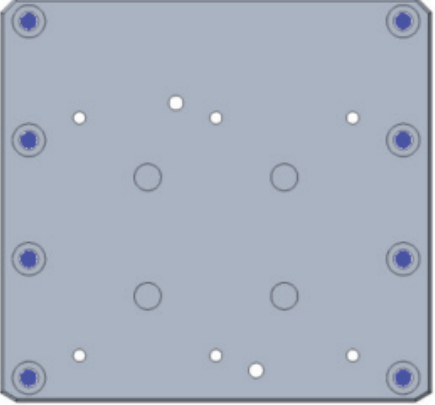
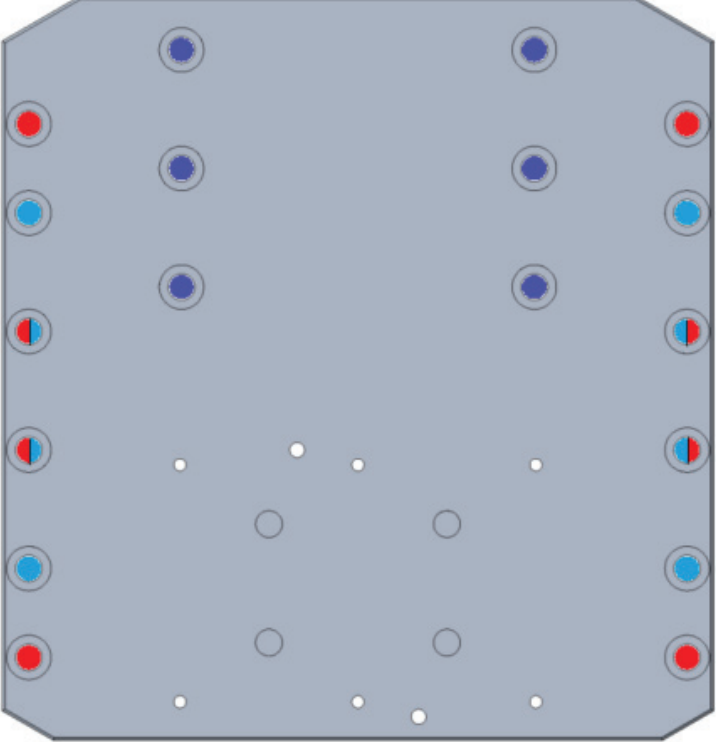
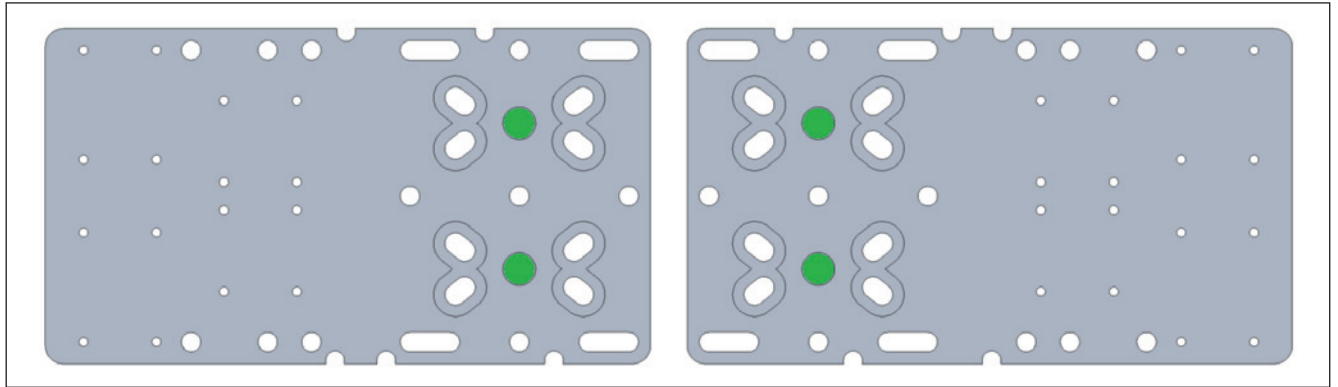

Fig. 15: Type 2 plate 1 dowel pins

6. Mount the flange of the dosing system with 4x DIN6912 M5x16 screws and 4x DIN125 5.3x10x1 washers on the plate 2 from behind. Depending on the mounting orientation selected (left (1) or right (2)), the lower hole pattern must be used. The size of the dosing system defines whether the inner 3RD3-EC, 3RD4-EC or outer ends (4RD6-EC, 3RD8-EC, 3RD10-EC, 3RD12-EC, 2RD12-3D-EC) of the elongated holes are required.

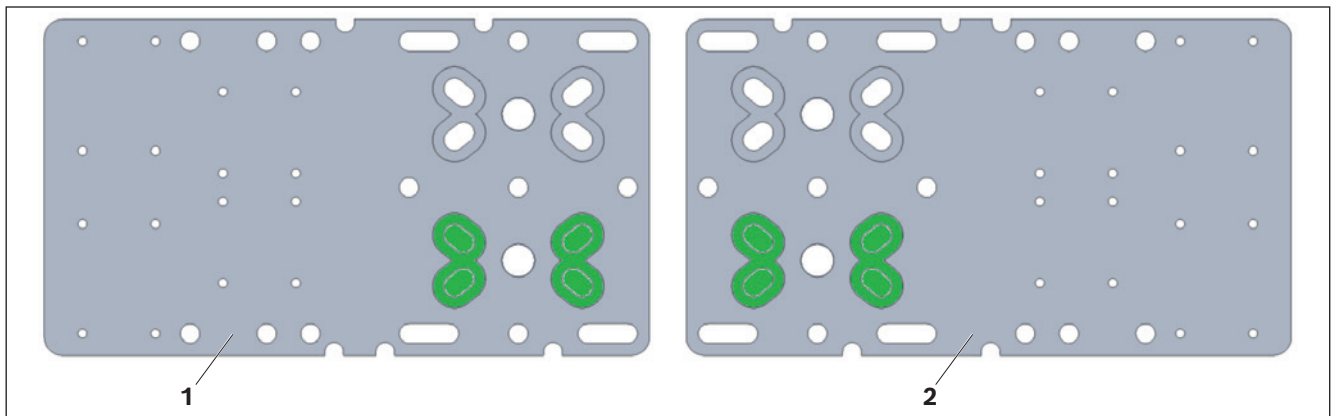

Fig. 16: Type 2 mounting dosing system on plate 2

7. Mount the bracket to the front of plate 2 using 4x ISO4762 M3x12 screws and 4x DIN125 3.2x7x0.5 washers. There are two hole patterns in plate 2 for attaching the bracket. The inner hole pattern is for the smaller curvature diameter ( $D = 20 \text{ cm}$ ) of the pipe for monitoring the inlet pressure and the outer for larger ones ( $D = 25 \text{ cm}$ ).

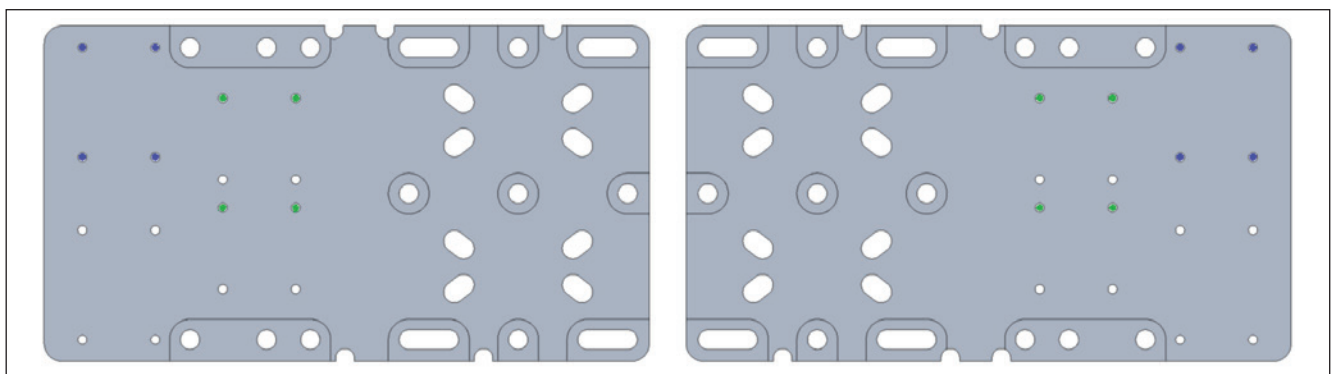

Fig. 17: Typ 2 mounting the angle on plate 2

8. There are 8 elongated holes in the lower leg of the bracket, 4 of which are required for **large dosing head sizes** or **normal dosing head sizes**.

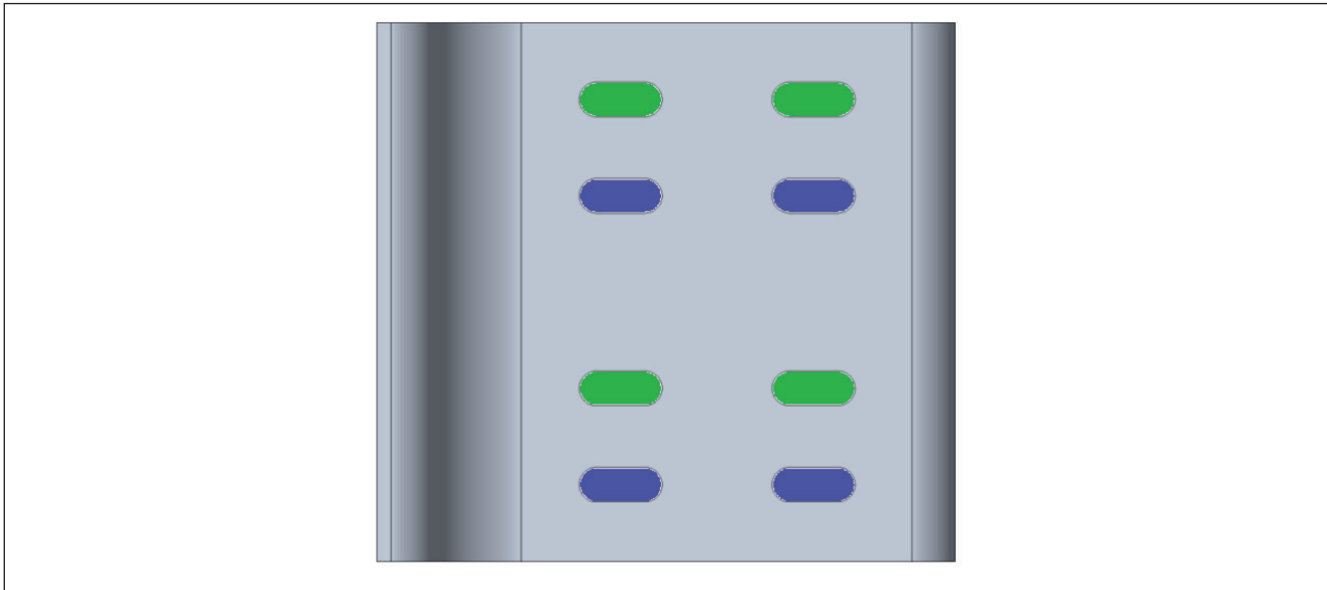

Fig. 18: **Typ 1 Winkel**

The large dosing head sizes include the 3RD12-ED and the 2RD12-3D-EC. The other heads of the RD-EC series belong to the normal hole pattern.

9. Now the pre-pressure monitor can be screwed to the two elongated holes in the left leg of the bracket using 2x ISO4762 M6x50, 2x DIN934 M6 and 2x DIN125 6.4x12x1.6 each.

10. Finally, plate 1 is attached to plate 2 together with the bracket and dosing system. Depending on the size of the plate 2 of the present adapter, other holes are used for this. The assignment of the holes to the sizes of plate 2 can be found in the graphic below.

The centering pieces and the dowel pins serve as an assembly aid and centering before screwing. The combination of plate 1, bracket and dosing system can be placed on the dowel pins in plate 2 with the grooves in plate 1. The dowel pins hold the assembly and protect against twisting during assembly. Then the plate 1 can be centered on the plate 2 with the centering pieces.

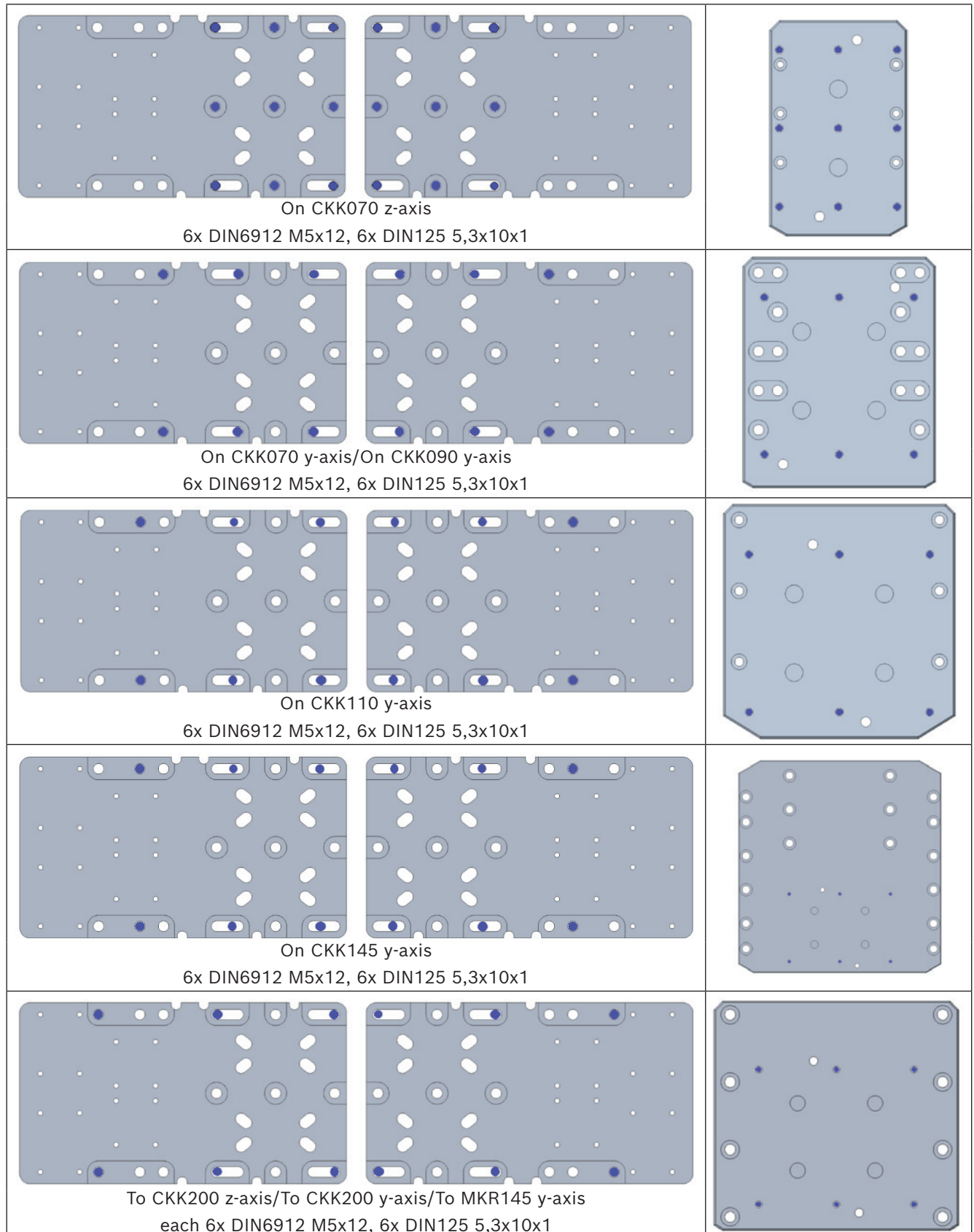

Fig. 19: Type 2 mounting plate 1 on plate 2

## 6.2 Dispense head sensor

Two sensors are set up to monitor the fill level. e.g. the capacitive sensor IFM KQ6004.



Fig. 20: Level sensor

Capacitive Sensor: Connector: 1X Open Collector DC PNP  
M8-connector

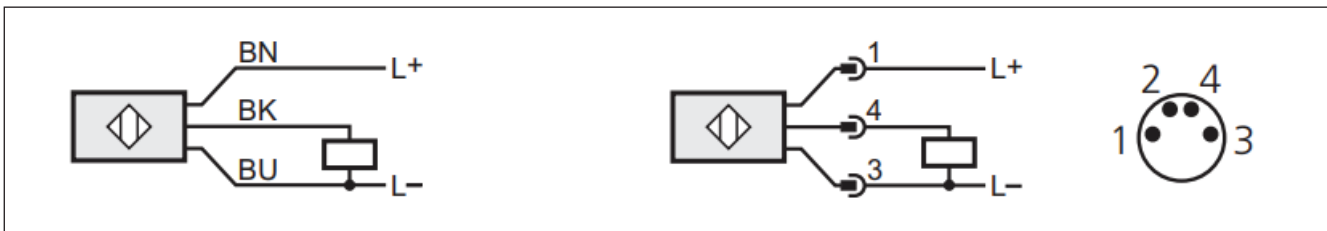

Fig. 21: P-switching connector (types ...FPKG..., or ...FPOG... )

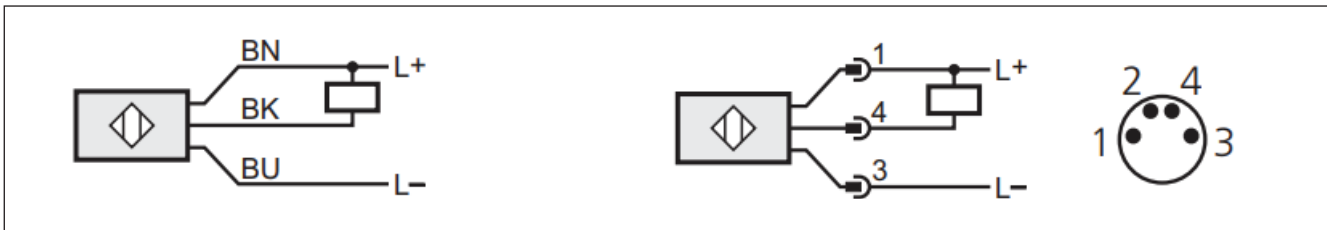

Fig. 22: Connectors n-switching (types ...FNKG..., or ...FNOG... )

- BN = brown
- BK = black
- BU = blue
- BN = OUT/IO-Link
- 1 = 24 V
- 2 = n.n.
- 3 = GND
- 4 = connect with digital input (z.B. S20-DIDO-8-1)

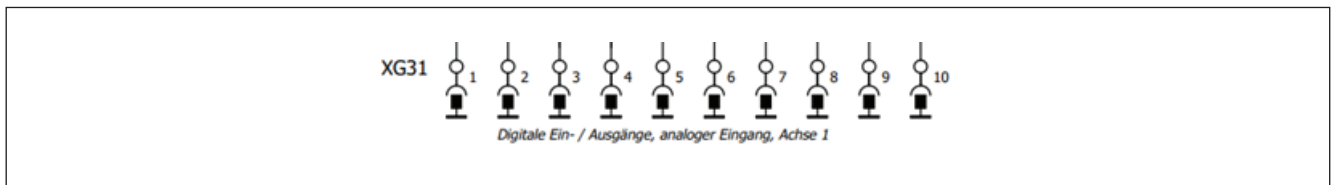

Fig. 23: Internal I/O module XG31 from the inverter

If external I/O module (e.g. S20-DIDO-8/1) were available, then 4th connection is connected to port 00 (for min. fill level) of S20-DIDO-8/1. Port 01 is used for max. fill level.

If no external I/O module (e.g. S20-DIDO-8/1) were available, then internal I/O module XG31 (digital inputs/outputs, analog inputs) from the inverter port 6 (min. level) and port 7 ( max. filling level) is used.

A SICK sensor is used to monitor dispensing pressure.

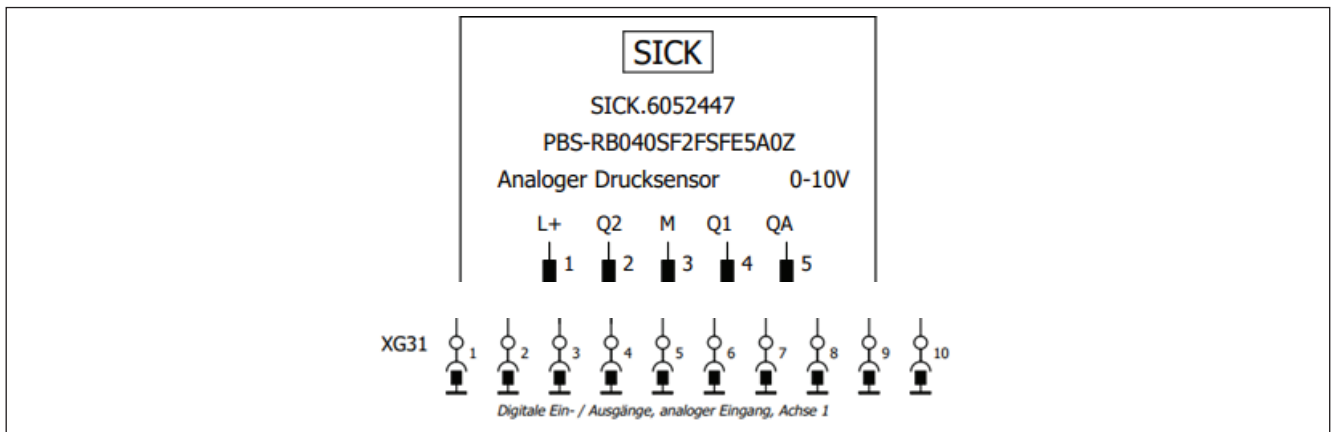

Fig. 24: SICK-Sensor

1: 24V

3: GND

4: connect to digital inputs.

If external I/O (e.g. S20-DIDO-8/1) were available, then Q1 is connected to port 10 of S20-DIDO-8/1.

If no external I/O would be available, then Q1 is connected to internal I/O module XG31 (digital inputs/outputs, analog inputs) port 1 of the inverter.

### 6.3 Dispenser drive

Connection of the inverter

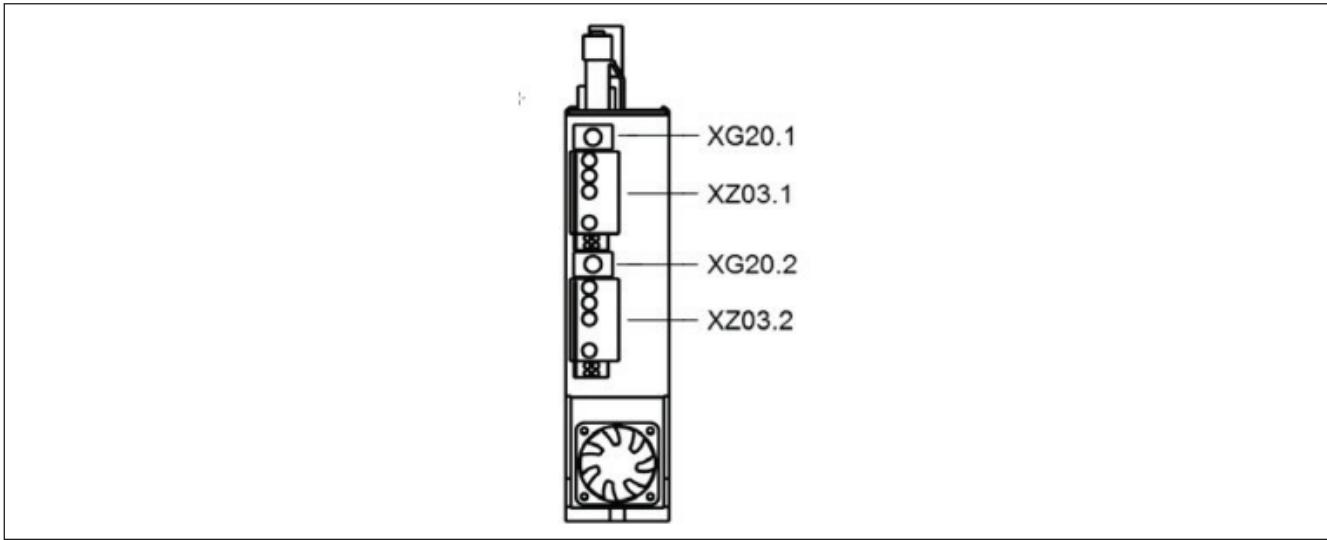

Fig. 25: Inverter

XG20: Digital encoder connection

XZ03: Motor connection and motor temperature monitoring and motor holding brake

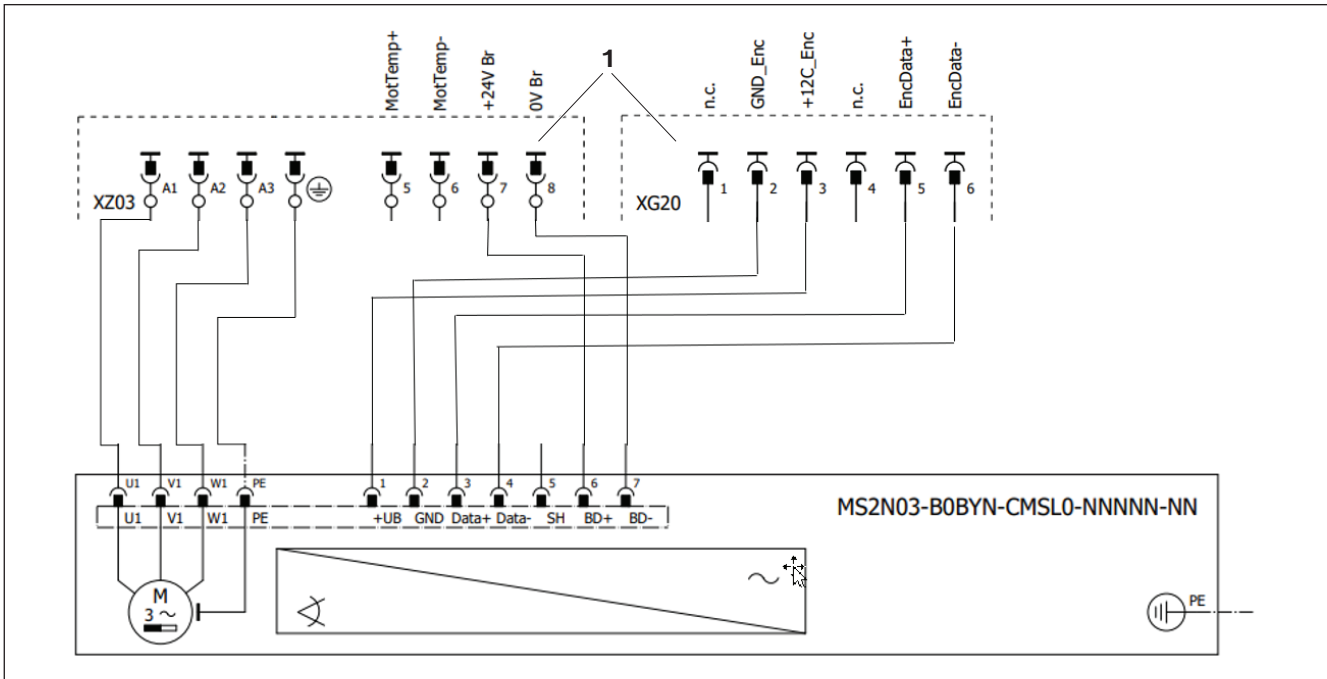

Fig. 26: Wiring dispenser drive

1 Connectors from XMD, or XZ03 and XG20

## 6.4 I/O modules

Optionally, an I/O expansion module can be selected, which is made up of the following individual parts to form a module:

When using EtherCAT, the order (according to EtherCAT.xml) must be observed.

Sequence: S20-EC-BK → S20-RS-UNI → S20-DIDO-8/1 → S20-DIDO-8/1

### S20-EC-BK

Supply voltage: 24V



 <ul style="list-style-type: none"> <li>• Up to 63 additional S20 participants can be connected</li> <li>• 2 RJ45 ports</li> <li>• rotary coding switch</li> <li>• Automatic addressing</li> <li>• Mapping of the station as a modular EtherCAT device using a modular device</li> <li>• Profiles (MDP)</li> </ul>	 <p>a1, a2 (red) 24 V DC b1, b2 (blue) GND</p>	 <p>Connection: EtherCAT</p>
---	---	---

Fig. 4: S20-EC-BK

### S20-RS-UNI



 <ul style="list-style-type: none"> <li>• 1 serial input and output channel in RS232 or RS485/422 version</li> <li>• Support of various protocols</li> <li>• Transmission rate adjustable up to 250,000 baud</li> <li>• Parameterization via the PDI channel</li> <li>• Electronic device nameplate</li> </ul>	 <p>a1, a2 (red) internally bridged b1, b2 (blue) internally bridged</p>	 <p>Interface wiring RS232: 4-wire handshake</p>
---	---	---

Fig. 5: S20-RS-UNI

**S20-DIDO-8/1**

Supply voltage: 24V

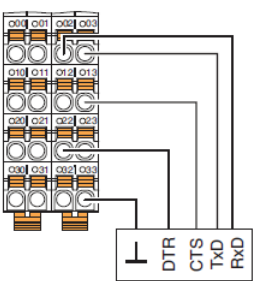

- 8 digital inputs and outputs
- 24V DC, 2.4mA input current, 0.5A output current
- Connection of the sensors and actuators in 1-wire technology
- Filter times adjustable in three stages: < 100  $\mu$ s, 1 000  $\mu$ s or 3 000  $\mu$ s
- Maximum input frequency: 5 kHz

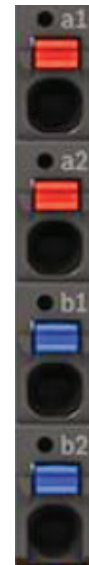

a1, a2 (red) 24 V DC  
b1, b2 (blue) GND



00,01,10,11 (digital inputs 1 ...4):  
00: level 1 on cartridge;  
01: Level 2 on cartridge  
20,21,30,31 (digital inputs 5 ...8)



02,03,12,13 (digital outputs 1 ... 4)  
02: check valve  
22,23,32,33 (digital outputs 5 ... 8)

Fig. 27: **S20-DIDO-8/1**

## 7 Energy installation

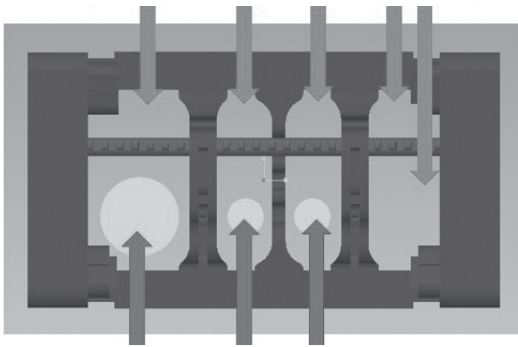

- ▶ For assembly, see the corresponding chapter in the instructions R320103109.

## 8 Installation

EN

### ! WARNING

#### Risks related to moving parts!

Moderate injury, including severe flesh wounds, puncture wounds and severe bruising.

- ▶ Never reach into moving parts.

#### Unexpected movement of the product!

Risk of injury due to impact or bruising.

- ▶ Before working on the electrical equipment, switch off the power supply and secure it against being switched on again.

#### Risk of electrical shocks through touching live parts!

Death or serious injury.

- ▶ Before working on the electrical equipment, switch off the power supply and secure it against being switched on again.
- ▶ Allow drive components to discharge before accessing them.
- ▶ Always operate the drive components with a permanently installed protective conductor.

### ! CAUTION

#### Unauthorized access to the product via network connection.

From malfunctions and data loss to damage to the product.

- ▶ Protect the network against unauthorized access by using a firewall or a Virtual Private Network (VPN), for example.
- ▶ Prevent a connection with the Internet by suitable measures.

### 8.1 General installation instructions

- ▶ Observe the required minimum distances during mounting (see technical data or dimension sheets).
- ▶ Rear mounting (rear side of the device is directly on the mounting surface in the control cabinet) is the standard and should be applied.
- ▶ Lay all lines in loops. Use strain reliefs for all lines.
- ▶ Do not lay signal-carrying cables parallel to motor cables or other strong interferers over long distances, as the signal transfer may otherwise be interfered.
- ▶ If possible, keep great distance to interference sources.

## 8.2 Introduction to topologies (controller combinations)

- General: Supply unit (ctrlX DRIVE plus +ctrlX Core) + inverter (ctrlX DRIVE)
- Variant 1: XCS1 (int. Core) + XMD1
- Variant 2: XCD1(int. Core) + XMS1

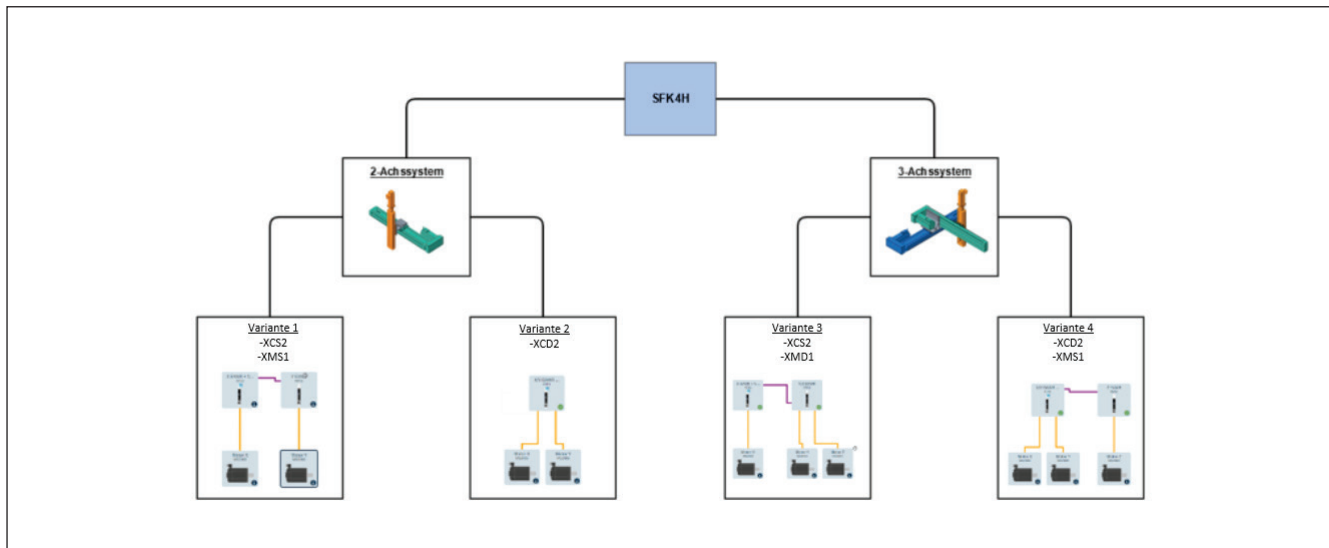

Fig. 28: Topologies

### 8.3 Installation of the drive controllers

#### 8.3.1 Description of power units

##### Single-axis converter XCS2

Front side	Top side	Bottom side
		
<p>XD02: Intermediate circuit</p>	<p>XD10: Control voltage XG02: Relay contact ready for operation</p>	<p>XD01: Mains connection XD03: Motor connection XD04: External brake resistor XG03: Motor temperature monitoring and motor holding brake XG20: Digital encoder connection</p>

Fig. 29: XCS1

##### Double-axis converter XCD2-W2323

Front side	Top side	Bottom side
		
<p>XD02: Intermediate circuit</p>	<p>XD10: Control voltage XG02: Relay contact ready for operation</p>	<p>XD01: Mains connection XD04: External brake resistor XG20: Digital encoder connection XZ03: Motor connection and motor temperature monitoring and motor holding brake</p>

Fig. 30: XCD1-W2323

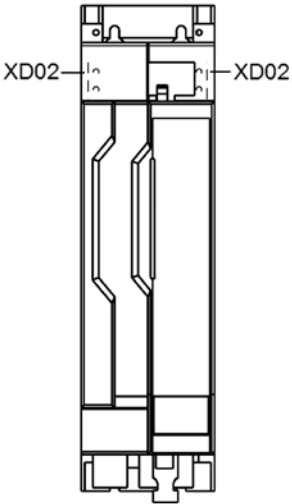
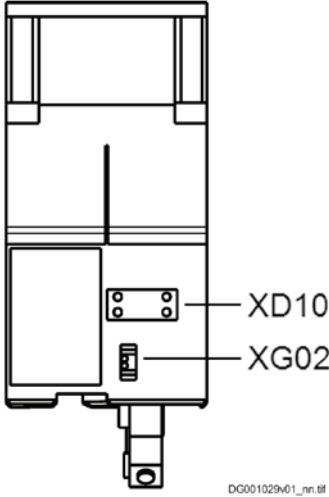
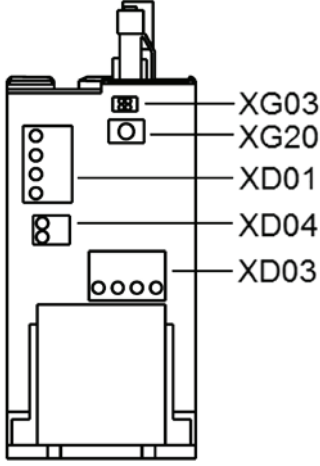
Single-axis inverter XMS1

Front side	Top side	Bottom side
		
<p>XD02: Intermediate circuit</p>	<p>XD10: Control voltage XG02: Relay contact ready for operation</p>	<p>XG20: Digital encoder connection XG03: Motor temperature monitoring and motor holding brake XD03: Motor connection</p>

Fig. 31: XMS1

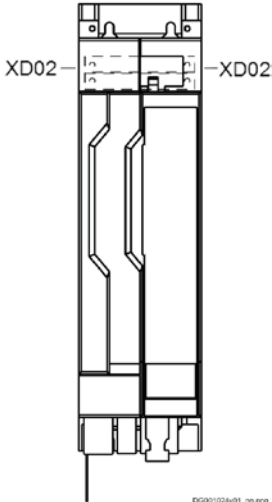
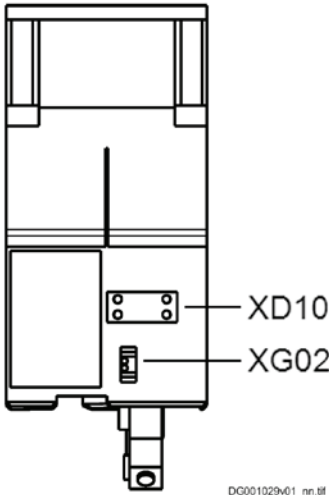
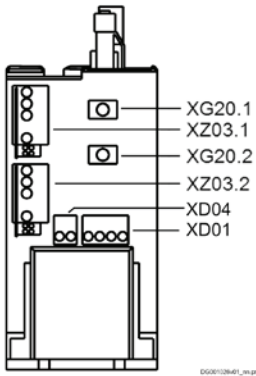
Double-axis inverter XMD1-W0606 ... W2323

Front side	Top side	Bottom side
		
<p>XD02: Intermediate circuit</p>	<p>XD10: Control voltage XG02: Relay contact ready for operation</p>	<p>XG20: Digital encoder connection XZ03: Motor connection and motor temperature monitoring and motor holding brake</p>

Fig. 32: XMD1-W0606 ... W2323

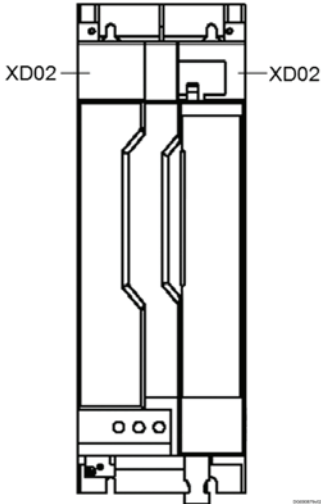
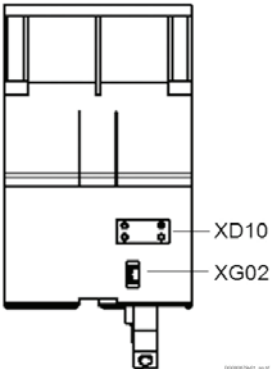
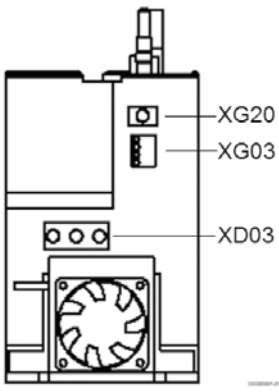
### 8.3.2 Description of control components

XCS2	XCD2	XMS1	XMD1
			
<p>XG21: Multi-encoder<sup>1)</sup>            XG31: Digital inputs/outputs, analog inputs            XG41: Safety engineering (Safe Torque Off)            XF23, XF24: Communication            XF10, XF50, X51: ctrlX DRIVE CORE</p>	<p>Xxxx.1: Axis 1            Xxx.2: Axis 2            XG21: Multi-encoder<sup>1)</sup>            XG31: Digital inputs/outputs, analog inputs            XG41: Safety engineering (Safe Torque Off)            XF23, XF24: Communication            XF10, XF50, XF51: ctrlX DRIVE CORE</p>	<p>XG21: Multi-encoder<sup>1)</sup>            XG31: Digital inputs/outputs, analog inputs            XG41: Safety engineering (Safe Torque Off)            XF21, XF22: Communication</p>	<p>Xxxx.1: Axis 1            Xxx.2: Axis 2            XG21: Multi-encoder<sup>1)</sup>            XG31: Digital inputs/outputs, analog inputs            XG41: Safety engineering (Safe Torque Off)            XF21, XF22: Communication</p>

Fig. 33: Description of control components

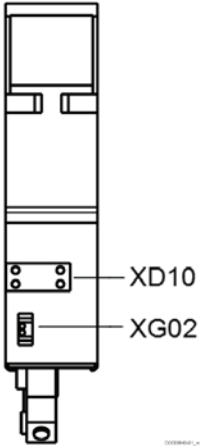
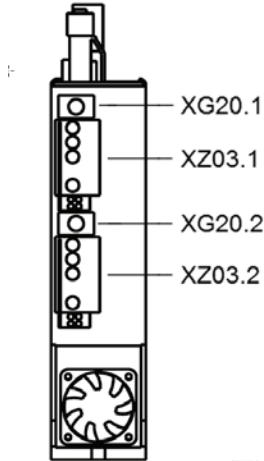
1) Optionally included, view may differ

## 8.4 Description of connection terminals

### 8.4.1 Protective conductor

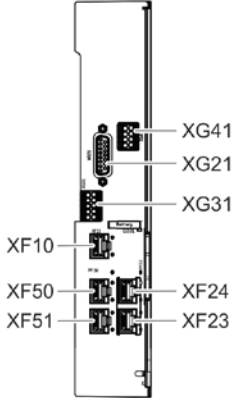
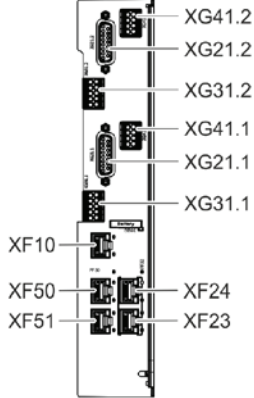
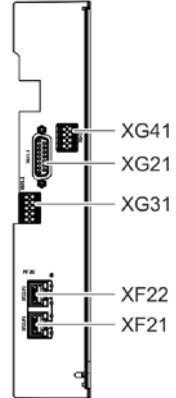
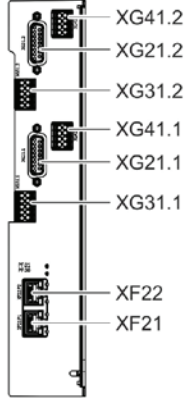
#### **! WARNING**

##### **High voltage at housing and high leakage current!**

Danger of death or injury caused by electrical shock!

- ▶ Before switching on and commissioning, ground or connect the components of the electrical drive and controller system with the protective conductor to the grounding points.
- ▶ Always connect the protective conductor of the components of the electrical drive and controller system firmly and permanently to the supply network. The leakage current is greater than 3.5 mA.
- ▶ Establish a protective conductor connection with at least 10 mm<sup>2</sup> copper cross-section or additionally lay a second protective conductor with the same cross-section as the original protective conductor.

#### **! WARNING**

##### **Fatal electric shock from live parts with more than 50 V!**

Death or serious injury.

Only operate the device with the attached

- ▶ connection plugs (even if there are no lines connected to the connection plugs) and
- ▶ with connected protective conductor!

### Protective conductor: Material and cross-section

For the protective conductor, use the same metal (e.g. copper) as for the phase conductors.

Ensure sufficient cross-section of the lines for the connections from the protective conductor connection to the protective conductor system in the control cabinet.

Cross-section of protective conductor connections:

For drive controllers Xxxn-Wxnnn with at least 10 mm<sup>2</sup>, but not smaller than the cross-section of the phase conductors of the mains supply line. In addition, mount the housing on a bare metallic mounting plate.

Also attach the mounting plate with the protective conductor system in the control cabinet with at least the same cross-section.

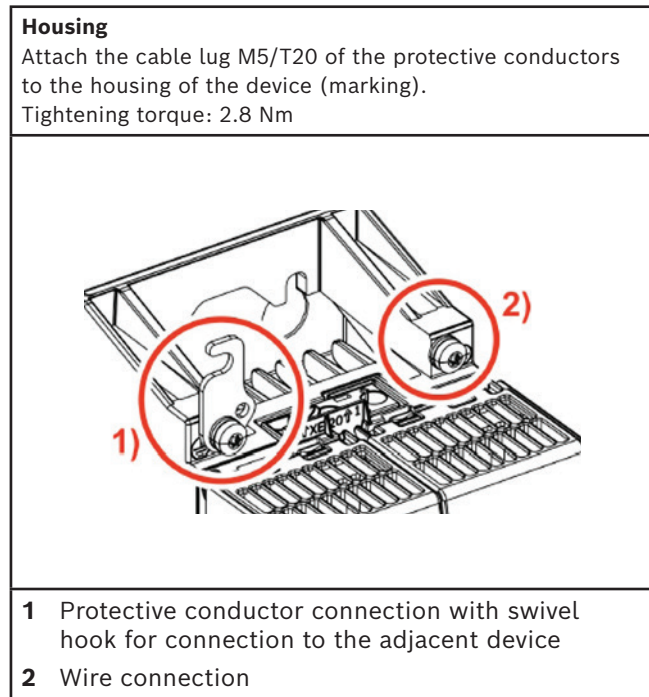

Fig. 34: Protective conductor connection

## 8.4.2 XD01, mains connection

**! WARNING****Fatal electric shock from live parts with more than 50 V!**

Death or serious injury.

Only operate the device

- ▶ with the attached connection plugs (even if there are no lines connected to the connection plugs) and
- ▶ with connected protective conductor!

**NOTICE**

Damage to the product due to missing strain relief of the connection terminals

- ▶ Ensure that the connection terminals of the device in the control cabinet are strain-relieved.

Tabelle 6: XD01, mains connection

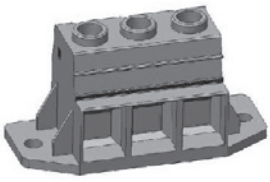
View	Marking	Function	
	L1	Connection to supply system (L1)	
	L2	Connection to supply system (L2)	
	L3	Connection to supply system (L3)	
Features			
Connection block	Unit	min.	max.
Connection cable	mm <sup>2</sup>	0.5	35
stranded wire	AWG	20	2
Insulation stripping length	mm	18	
Tightening torque ( $\leq 25 \text{ mm}^2$ )	Nm	2.5	
Tightening torque ( $\geq 25 \text{ mm}^2$ )	Nm	4.5	
occurring current load and minimum required connection cross-section		see technical data of the device used ( $I_{LN}$ and $A_{LN}$ )	
occurring voltage load		see technical data of the device used ( $U_{LN}$ or $U_{LN,nom}$ )	

### 8.4.3 Intermediate circuit connection XD02 L+ L-

#### **! WARNING**

##### **Fatal electric shock from live parts with more than 50 V!**

Death or serious injury.

- ▶ Before starting work on live parts: De-energize the system and secure the mains switch against unintentional or unauthorized reactivation.  
After switching off the supply voltages, wait for the discharge time of at least 30 minutes before accessing the device.  
Check whether the voltage has fallen below 50 V before touching live parts!  
Never operate the device without contact protection

#### **Function, pin assignment**

The intermediate circuit connection connects

- multiple devices with one another
- a device with an intermediate circuit capacitor unit (for support of the intermediate circuit voltage)
- Tightening torque 2.8 Nm

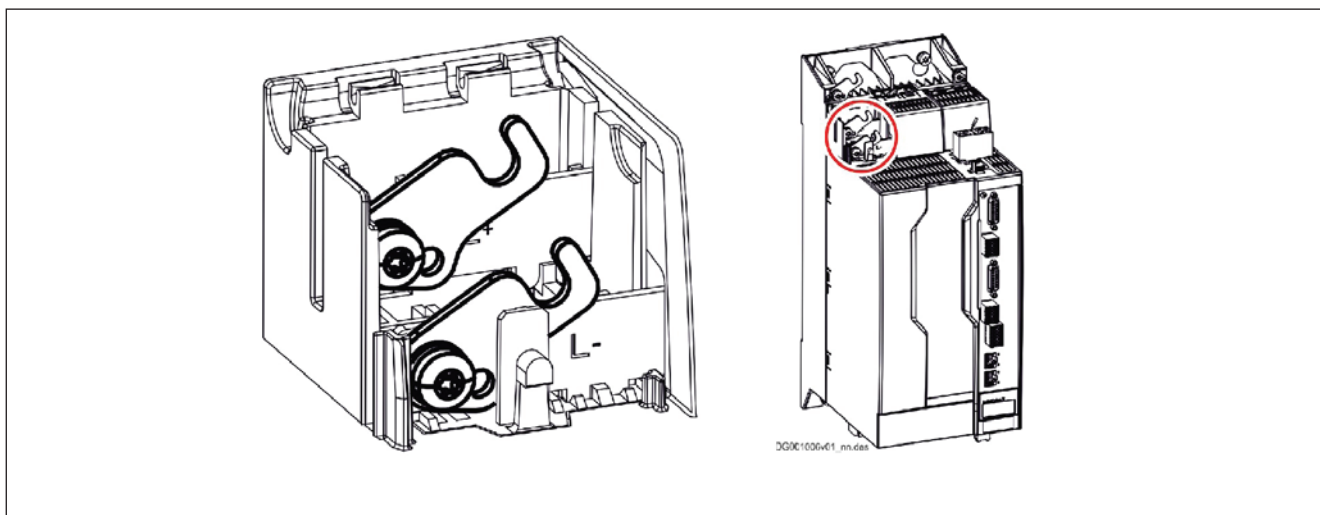
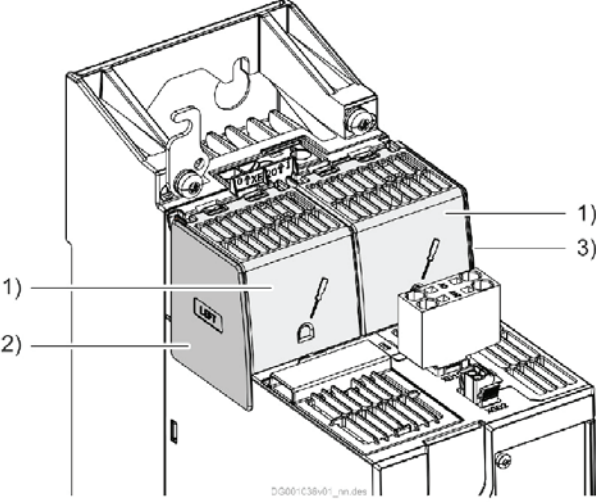
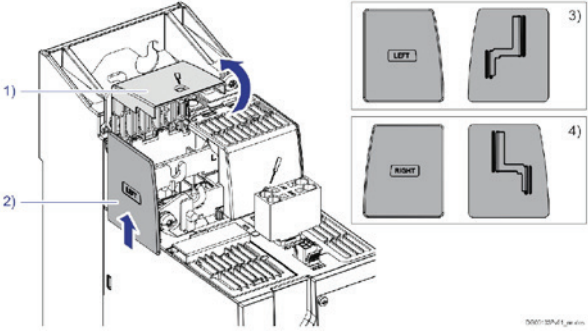

Fig. 35: Swivel hook for intermediate circuit connection

Tabelle 7: Contact protection

Contact protection	Dismounting the contact protection
	
<p>1 Contact protection flap 2 Contact protection plate (LEFT; R911400453) 3 Contact protection plate (RIGHT; R911400452)</p>	<p>1 Contact protection flap 2 Contact protection plate 3 Contact protection plate, left (front and rear) 4 Contact protection plate, right (front and rear)</p>
<p>By default, the devices are delivered with contact protection. The contact protection plate may only be removed to connect the intermediate circuit of adjacent devices.</p>	<p>Dismounting the contact protection 1. Unlock and open the contact protection flap. 2. Vertically move the contact protection flap upwards and remove.</p>

EN

### Axis grouping

If several devices are mounted next to each other in the axis grouping:

- ▶ Before mounting: Remove all superfluous contact protection plates.
- ▶ After mounting: Make sure that the contact protection is present on the first and last device.

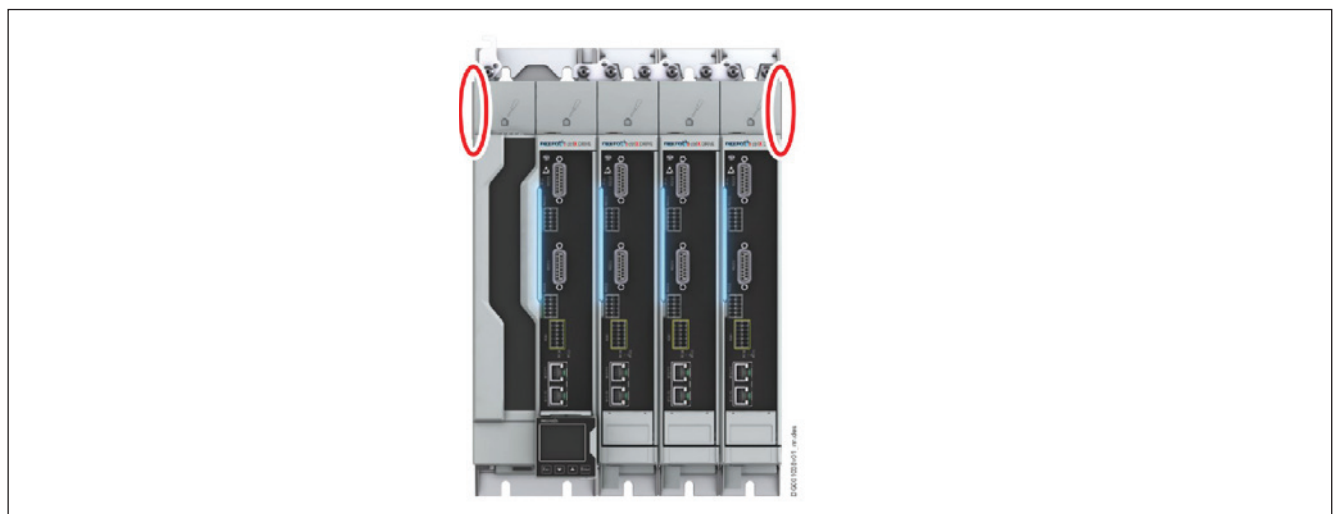

Fig. 36: Axis grouping

#### 8.4.4 XZ03, hybrid connection

##### Motor, motor temperature monitoring and motor holding brake

##### Function, pin assignment

Function. The connection point contains the connections for

- the motor power supply
- monitoring the motor temperature
- control of the motor holding brake

 **The included hybrid cable has this connection.**

### **WARNING**

#### **Dangerous movements! Risk of personal injury due to falling or descending axes!**

Death or serious injury.

The motor holding brake supplied as standard or an external motor holding brake controlled by the drive controller is not suitable for protection for personnel alone!

Protect persons by means of superior, fail-safe measures:

- ▶ Locking of the danger zone by means of protective fences or safeguards
- ▶ Additionally secure vertical axes from falling or lowering after the
  - motor has switched off, e.g. by mechanically locking the vertical axes
  - external braking/catching/clamping devices
  - sufficient counterbalancing on the axes

### **WARNING**

#### **Fatal electric shock from live parts with more than 50 V!**

Death or serious injury.

- ▶ The input of the motor temperature evaluation is not galvanically isolated from the housing. If there is an inadmissibly high voltage at the input (e.g. due to the motor winding voltage being exceeded), this voltage may reach the housing. Make sure that the temperature sensor of the connected motor is double insulated from the motor winding.

### **WARNING**

#### **Fatal electric shock from live parts with more than 50 V!**

Death or serious injury.

Only operate the device

- ▶ with the attached connection plugs (even if there are no lines connected to the connection plugs) and
- ▶ with connected protective conductor!

### **NOTICE**

Damage to the product due to missing strain relief of the connection terminals



- ▶ Ensure that the connection terminals of the device in the control cabinet are strain-relieved.

### **NOTICE**

Damage to the product due to excessive voltage at the input of the motor temperature evaluation

- ▶ At the input of the motor temperature evaluation, only voltage corresponding to the permissible control voltage of the device is permissible.
- ▶ In case of impermissibly high voltage at the input, the device may be damaged.

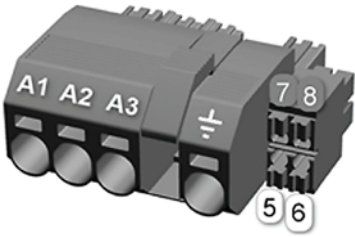
Tabelle 8: Motor power supply

View	Marking	Function
	A1	for line terminal U1 at the motor
	A2	for line terminal V1 at the motor
	A3	for line terminal W1 at the motor
		for protective conductor connection on the motor
Features		
Spring clamp (plug)	Unit	min.
Connection cable	mm <sup>2</sup>	0.5
stranded wire	AWG	24
Insulation stripping length	mm	12
occurring current load and minimum required connection cross-section	A	see technical data of the device used ( $I_{out}$ )
occurring voltage load	V	see technical data of the device used ( $U_{out}$ )
Short-circuit protection		A1, A2, A3 among each other and against ground

EN

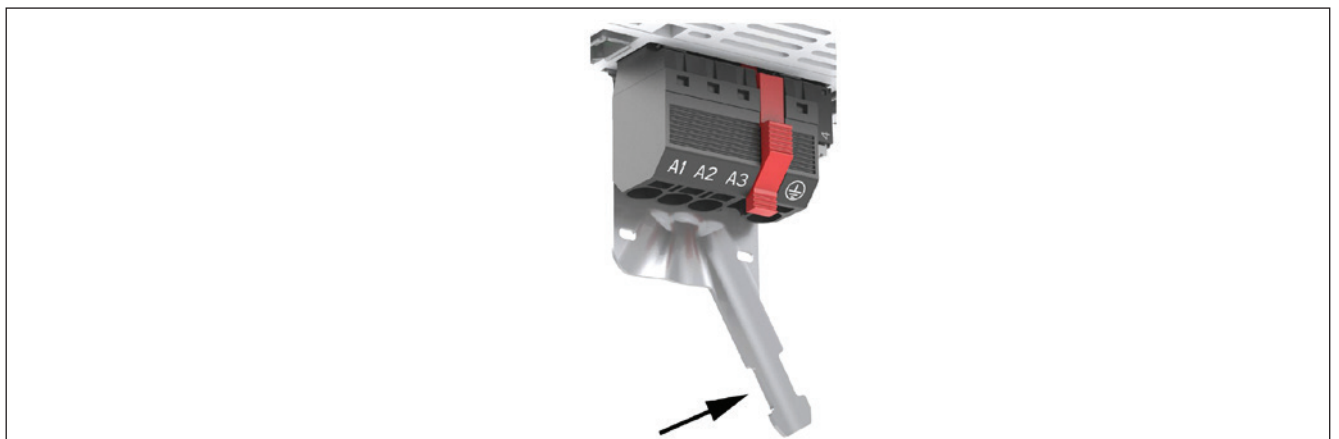
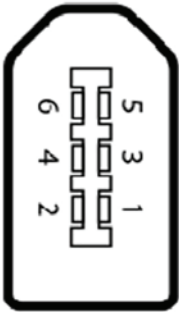

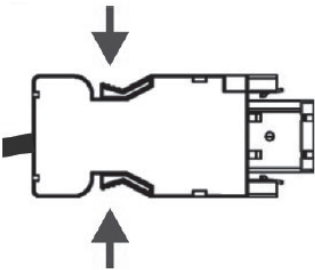
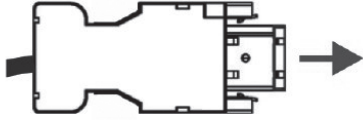

Fig. 37: Shield connection, motor cable

### 8.4.5 Motor encoder XG20 (hybrid cable)

Tabelle 9: Motor encoder XG20

View	Connection	Signal name	Function
	1	n.c.	-
	2	GND_Enc	Reference potential for the power supplies
	3	+12V_Enc	Encoder supply 12 V
	4	n.c.	-
	5	Enc_Data+	Data transfer positive
	6	Enc_Data-	Data transfer negative
Features			
	Unit	min.	max.
Connection cable, stranded wire	mm <sup>2</sup>	0.25	0.5
Type of encoder evaluation		ACURO®link	

#### Loosen the plug connection

1. Press and hold the side keys at the plug.	2. Press the plug in the direction of insert.	3. Pull out the plug.
		

Encoder connection for hybrid cables. Hybrid cables (e.g. RHB2-021DDB) connect the drive controller with motor (XZ03) and encoder (XG20).

- ▶ Lead the encoder cable to connection point XG20 in the form of a loop so that no force acts on the encoder plug.

### 8.4.6 XG02, Bb relay contact

Tabelle 10: XG02

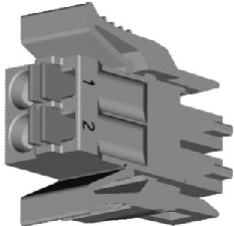
View	Connection	Signal name	Function
	5	MotTemp+	Motor temperature monitoring input
	6	MotTemp-	
	7	+24 VBr	Output for controlling the motor holding brake
	8	0VBr	
Features			
Spring clamp (plug)	Unit	min.	max.
Connection cable	mm <sup>2</sup>	0.2	1.5
stranded wire	AWG	24	16
Insulation stripping length	mm		10
Load capacity of the contacts	V		30
	A	0.01	1

### 8.4.7 XD10, 24 V supply (control voltage)

Via the connection point, the 24 V power supply is externally created for

- the controller and power unit of the drive control unit
- the brake piloting
- the digital inputs and the digital output

**Tabelle 11: XD10**

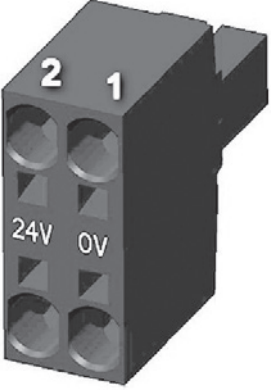
View	Connection	Signal name	Function
	1	0 V	Reference potential for the power supply
	2	+24 V	Power supply
Features			
Screw connection at the plug	Unit	min.	max.
Connection cable	mm <sup>2</sup>	0.2	6
stranded wire	AWG	24	8
Insulation stripping length	mm	10	
Power consumption	W	PN3 (see control voltage data)	
Voltage load capacity	V	UN3 (see control voltage data)	
Current carrying capacity "looping through" from 0V to 0V, 24V to 24V	A	41	
Reverse-polarity protection		within the permissible voltage range via internal protective diode	
Insulation monitoring		switch	

Installation instructions, requirements on the connection for the 24 V supply:

- Minimum cross-section: 1 mm<sup>2</sup>
  - Maximum permissible inductance: 100 µH (2 twisted, 75 m long single strands)
  - Routing as parallel as possible
- Depending on the power consumption of the devices and the current carrying capacity of the plug, check how many devices a cable for the 24 V supply can be looped through. You may have to connect another device directly to the 24 V supply and loop through the control voltage from this device to other devices.

### 8.4.8 Communication (EtherCAT slave) (XMD1/XMS1/XF21/P1)

The connection point complies with standard IEEE 802.3.

P1, P2 stands for "port 1" and P2 stands for "port 2". In this way, the error counter of the firmware can be directly assigned to a port.

#### Connection Sercos:

- Input: any
- Output: any

#### EtherCAT:

- Received: XF21 P1
- Output: XF22 P2

Tabelle 12: XMD1/XMS1/XF21/P1

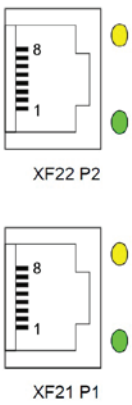
View	Connection	Signal name	Function
 <p>XF22 P2</p> <p>XF21 P1</p>	8	n. c.	-
	7	n. c.	-
	6	RD-	Receive, differential input -
	5	n. c.	-
	4	n. c.	-
	3	RD+	Receive, differential input +
	2	TD-	Transmit, differential output -
	1	TD+	Transmit, differential output +
	Housing		Shield connection
<b>Features</b>			
Standard	<ul style="list-style-type: none"> <li>• Ethernet</li> <li>• Type: RJ-45, 8-pin</li> </ul>		

### 8.4.9 XG31, digital inputs and outputs, analog input

Tabelle 13: XG31

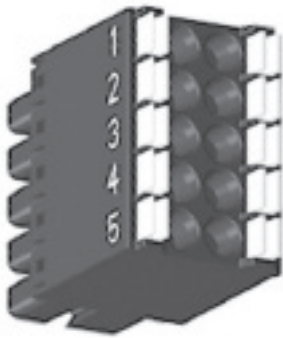
View	Connection	Signal name	Function	Default assignment
	1	I_1	digital input (type B)	Measuring probe 1
	2	I_2		Measuring probe 2
	3	I_3	digital input	E-stop input
	4	0 V	GND reference	-
	5	0V_100	Analog input Connection for internal cable shield	-
	6	I_4	digital input	Travel range limit switch input
	7	I_5	digital input	Travel range limit switch input
	8	I_6/O_1	digital input/output	not assigned
	9	I_a_1+	analog differential input	not assigned
	10	I_a_1-		not assigned
Features				
Spring clamp (plug)	Unit	min.	max.	
Connection cable				
stranded wire	mm <sup>2</sup>	0.2	1.5	
	AWG	24	16	
Insulation stripping length	mm	-	10	

Connection 1: E-stop

Connection 2: Reset error class (E-stop)

Connection 8: Output display E-stop

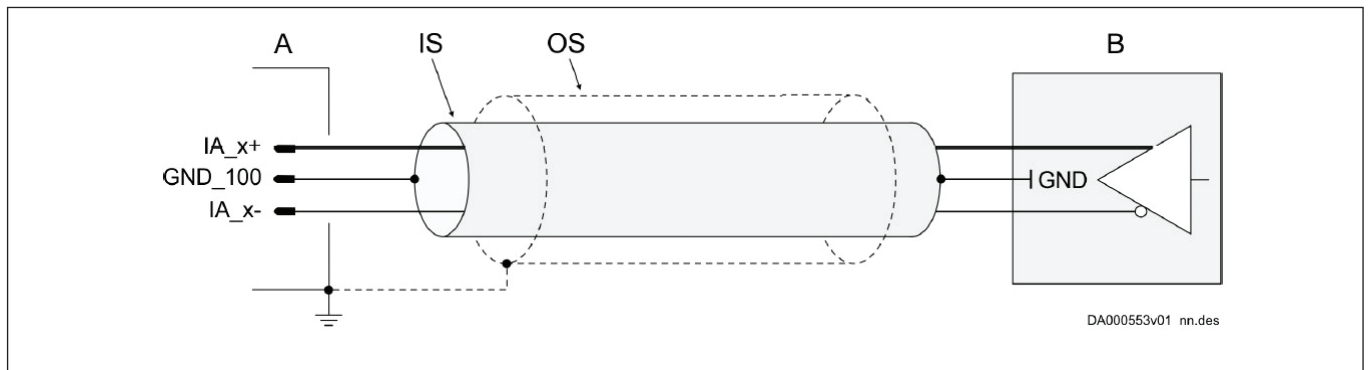

Fig. 38: Shield connection, motor cable

**A** Analog input of the drive unit. The internal shield of the connection cable may only be connected to the drive unit if GND is not connected to ground in the external device.

**B** External device

**IS** Internal shield of the connection cable

**OS** External shield of the connection cable

### 8.4.10 XG41, safety engineering Safe Torque Off single axis; double axis

Tabelle 14: XG41

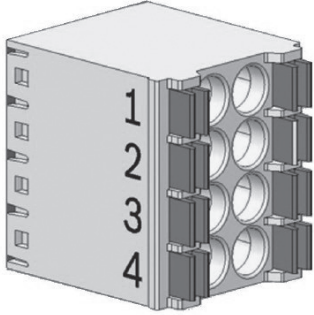
View	Connection	Signal name	Function
	1	STO_DynOut_CH1	Dynamization output channel 1
	2	-	n. c.
	3	STO_CH1	Input selection channel 1
	4	STO_CH1	Input selection channel 1
	5	STO_DynOut_CH2	Dynamization output channel 2
	6	-	n. c.
	7	STO_CH2	Input selection channel 2
	8	STO_CH2	Input selection channel 2
Features			
Spring clamp (plug)	Unit	min.	max.
Connection cable	mm <sup>2</sup>	0.2	1.5
stranded wire	AWG	24	16
Insulation stripping length	mm	-	10

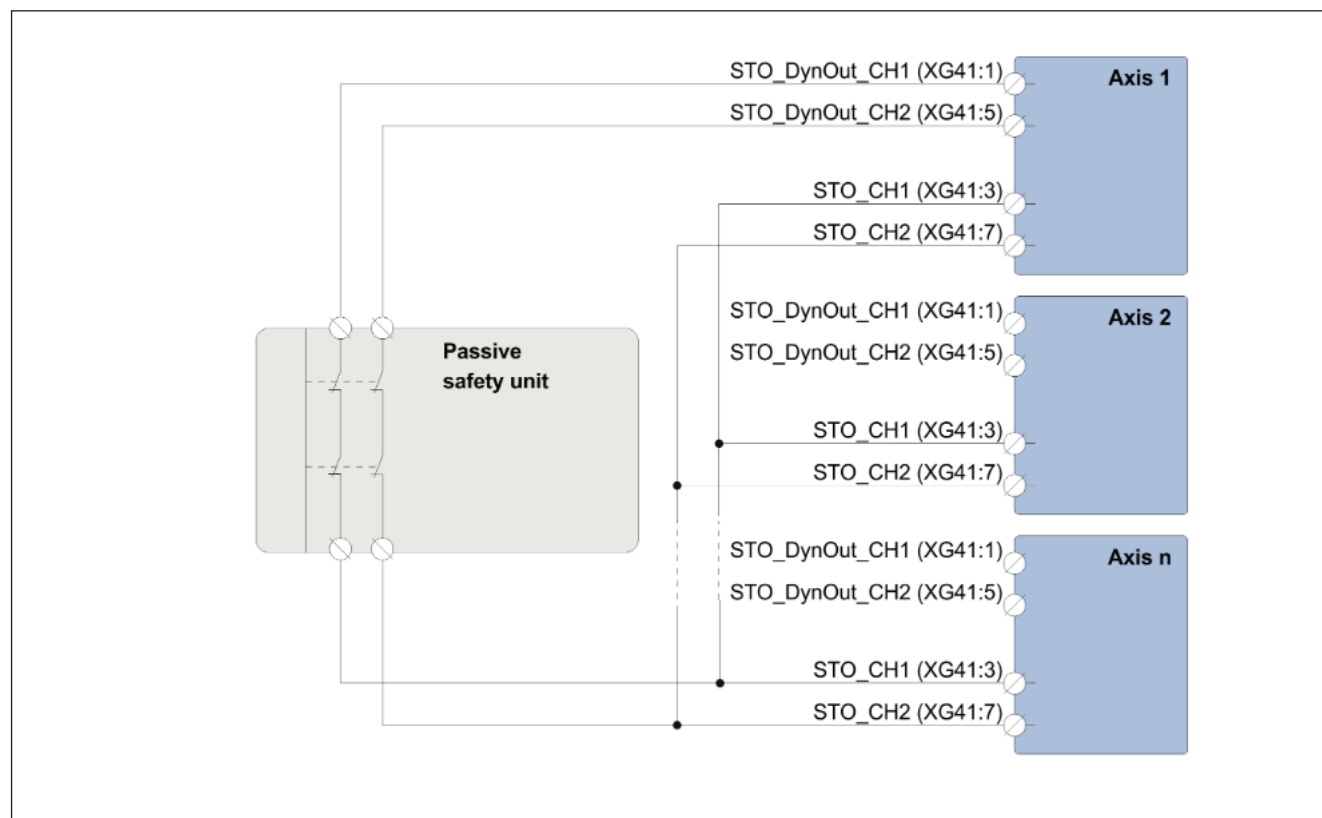

Fig. 39: Safety engineering Safe Torque Off

### 8.4.11 ctrlX Drive plus with ctrlX CORE

- XF10 = HMI/engineering PC
- XF50 = EtherCAT master (for XF21 with slave)

Configurable drives ctrlX DRIVE<sup>plus</sup> can be equipped with an internal ctrlX CORE controller.

**Tabelle 15: Connection points ctrlX CORE**

View	Connection	Function
<p>DA000899-v01_en.dwg</p>	GB01	Battery compartment for buffer battery for buffering system time; RTC (real time clock)
	XF10	Ethernet engineering port
	PF24	Activity LED (yellow)
	PF25	Link LED (green)
	PF31	Status LED; Ethernet axis 2 (two-color)
	PF30	Status LED; Ethernet axis 1 (two-color)
	XF50	Ethernet-based field bus port 1
	PF91	Activity LED (yellow)
	PF92	Link LED (green)
	XF51	Ethernet-based field bus port 2
	PF93	Activity LED (yellow)
	PF94	Link LED (green)
	CF01	Slot: MicroSD memory card

**XF10, XF50, XF51**

Description. The connection point complies with standard IEEE 802.3.

P1, P2, P3 stands for "port 1" and P2 stands for "port 2", etc. The error counter of the firmware can thus be directly assigned to a port.

**Connection XF10: Fast Ethernet interface for network connection**

- Ethernet engineering

**Connection XF50: Fast Ethernet interface for Ethernet-based field buses (master)**

- EtherCAT master output

**Connection XF51: Fast Ethernet interface for Ethernet-based field buses**

- EtherCAT master output (option)
- Ethernet engineering (option)

**Tabelle 16: XF10, XF50, XF51**

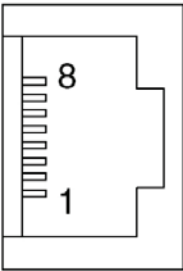
View	Connection	Signal name	Function
 <p>DG000272v01_nn.fh11</p>	8	n. c.	-
	7	n. c.	-
	6	RD-	Receive, differential input -
	5	n. c.	-
	4	n. c.	-
	3	RD+	Receive, differential input +
	2	TD-	Transmit, differential output -
	1	TD+	Transmit, differential output +
	Housing		Shield connection
<b>Features</b>			
Standard	<ul style="list-style-type: none"> <li>• Ethernet</li> <li>• Type: RJ-45, 8-pin, shielded</li> </ul>		

## 9 Connection of the HMI terminal device

### 9.1 Requirements

The Smart Function Kit for Handling provides an intuitive, web-based HMI for commissioning, configuration and programming of the system.

The following requirements apply for the required customer-supplied HMI device (e.g. notebook, tablet):

- Web browser with HTML5 and Java Script support  
e.g. Firefox version 52 or higher, Chrome version 74 or higher
- Screen resolution 1280 x 720 px or higher
- Recommended screen diagonal 10 inches (format 16:9) or higher
- The end device must be "browser-capable" in order to have access to our WEB HMI.

### 9.2 Direct connection to the Smart Function Kit for Handling

- For the network connection between the ctrlX Core and your HMI device, use a Cat5e network cable
- To do so, use connection XF10 at the supply unit (XCS2/XCD2)
- There must be a valid TCP/IP network connection between the HMI device and the ctrlX Core. Please observe the network settings on the HMI device and adapt them, if necessary.
- IP addresses: 192.168.1.1 (web interface)
- Subnet mask: 255.255.255.0
- User/password: boschrexroth / boschrexroth (STANDARD)

#### 9.2.1 Setting the IP addresses

The system is configured with the following network settings by default:

- XF5 192.168.1.100
- X26 192.168.1.1
- XF6 192.168.0.1 (access to HMI)
- Subnet mask 255.255.255.0

The IP address for access to the HMI (interface XF6) can be adjusted on the interface of the Smart Function Kit. The address section 192.168.1.x cannot be used.

### 9.3 Connection of a higher-level controller

The Smart Function Kit for Handling can be connected to a higher-level controller via a field bus, and controlled and monitored by means of this controller. In this configuration, the Smart Function Kit for Handling is the field bus slave and the higher-level controller commands as the field bus master.

The system currently supports the connection via OPC-UA to the higher-level controller.

- The Smart Function Kit has an OPC UA server
- Connection is established via the OPC UA client (S7-1500; UaExpert)
- Details see software instructions of the Smart Function Kit for Handling  
(PROFINET, Ethercat and Ethernet/IP are in preparation)

For further information on the implementation of the field bus ➡ "Smart Function Kit Software" instructions.

## 9.4 Connection to the IT infrastructure

### CAUTION

#### **Unauthorized access to the product via network connection.**

From malfunctions and data loss to damage to the product.

- ▶ Protect the network against unauthorized access by using a firewall or a Virtual Private Network (VPN), for example.
- ▶ Prevent a connection with the Internet by suitable measures.

For implementation into an IT system, the Smart Function Kit for Handling must be integrated into the corresponding network.

For this connection, use interface XF21 or XF22.

The IP address for the interface can be changed in the ctrlX interface.

The operation of systems and machines generally requires the implementation of a holistic IT security concept which is state-of-the-art.

Bosch Rexroth products are part of this holistic concept. The properties of the Bosch Rexroth products must be taken into account in a holistic IT security concept. The properties to be taken into account are documented in the IT security guidelines (R911342561).

## 10 Commissioning

- ▶ Do not start up the product until it has been verified that the end product (for example a machine or system) into which the Rexroth product has been installed complies with the country-specific requirements, safety regulations and standards for the application.

### 10.1 Checking the operating conditions

Observe ambient temperature, load, travel speed, stroke, etc. ➔ Chapter "Operating conditions".

<b>! WARNING</b>
<p><b>Risks related to moving parts!</b> Moderate injury, including severe flesh wounds, puncture wounds and severe bruising.</p> <ul style="list-style-type: none"> <li>▶ Never reach into moving parts.</li> </ul>
<p><b>Risk of break-up during operation!</b> Death or severe injury.</p> <ul style="list-style-type: none"> <li>▶ Do not expose the product to any mechanical loads under any circumstances.</li> </ul>
<p><b>Risk of electrical shocks through touching live parts!</b> Death or serious injury.</p> <ul style="list-style-type: none"> <li>▶ Before working on the electrical equipment, switch off the power supply and secure it against being switched on again.</li> </ul>

The Smart Function Kit must not be put into service until it has been verified that the final product (for example a machine or system) into which the Rexroth product has been installed complies with the country-specific requirements, safety regulations and standards for the application.

<b>! CAUTION</b>
<p><b>Hot surfaces with temperatures above 60 °C.</b> Risk of burns</p> <ul style="list-style-type: none"> <li>▶ Do not touch hot surfaces.</li> <li>▶ If required, install a guard to prevent accidental contact.</li> <li>▶ Protect from burns by wearing appropriate protective clothing, e.g. heat-resistant gloves.</li> </ul>
<p><b>Increased noise build-up!</b> Continuous exposure can lead to damage to hearing.</p> <ul style="list-style-type: none"> <li>▶ If excessive noise is generated, wear ear protectors and check for any damage.</li> </ul>
<p><b>Slipping on escaping lubricants!</b> Slipping.</p> <ul style="list-style-type: none"> <li>▶ Take suitable precautions to collect any escaping lubricant and dispose of it in the proper way.</li> </ul>

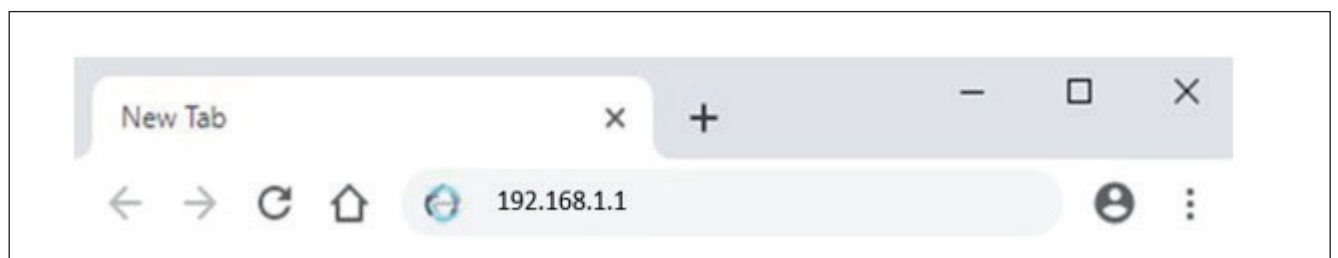

Fig. 40: Entering the IP address

## Initial commissioning

For initial commissioning, the Smart Function Kit for Handling must be completely pre-wired and switched on. After switching on the system, it takes approx. 100 seconds to start up completely.

- ▶ Ensure that your HMI terminal device or a commissioning PC is connected with the network of the Smart Function Kit (➔ 9 "Connection of the HMI terminal device").
- ▶ Check the network settings of your HMI terminal device (➔ 9 "Connection of the HMI terminal device").
- ▶ Open your web browser and enter the IP address of the Smart Function Kit (standard: 192.168.1.1). The web browser will now automatically connect to the Smart Function Kit.
- ▶ Depending on the security settings of your web browser and on the browser, a security warning to be confirmed will appear during connection establishment.
- ▶ Depending on the configuration of the browser, deleting its cache is necessary.
- ▶ Now, the login screen appears... The default user name/password is boschrexroth / boschrexroth. You will then be prompted to change the user name and password.

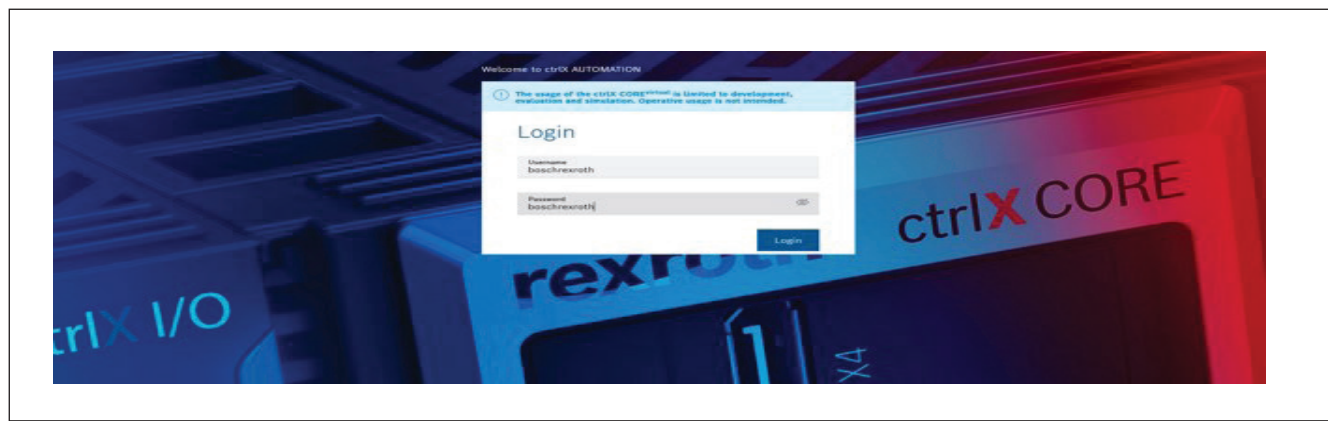

Fig. 41: Login screen ctrlX

- ▶ Now you enter the ctrlX interface, where you can now start the Smart Function Kit for Handling app. Please click on the tile "rexroth-sfk4handling" on "open".

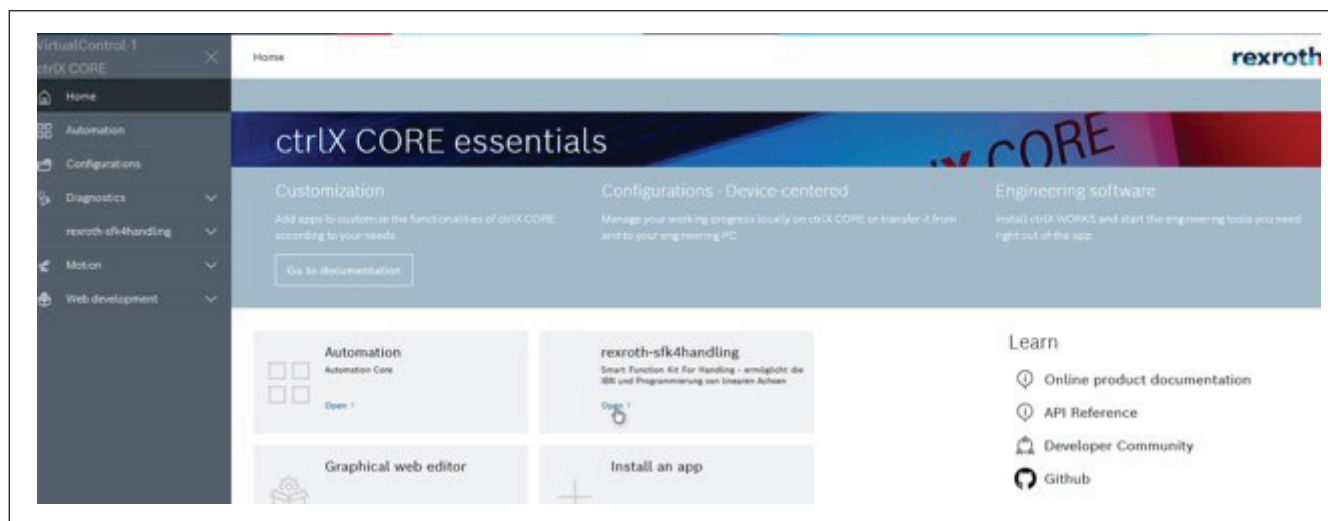

Fig. 42: ctrlX interface

- ▶ For details about the Smart Function Kit for Handling app, please refer to the software instructions for the SFK4H.

## 10.2 Commissioning (trial run, running in)

### **NOTICE**

#### **Malfunction of the product!**

Damage to the product.

- ▶ Only start up the product after running successful tests under simulated production conditions.
- ▶ Move at low speed over the entire stroke.
- ▶ Optimize the interaction of the mechanical system and the electronics.

## 10.3 Operation

### **NOTICE**

#### **Escaping lubricants and anti-corrosion medium**

Damage to the environment.

- ▶ Take suitable precautions to collect any escaping lubricant and dispose of it in the proper way.

### **NOTICE**

#### **Risk of motor overheating when overloaded!**

Damage to the product/fire.

- ▶ During operation, be sure to comply with technical data such as load rating, torques, maximum rotary speeds, motor data, etc.

For further information for operation of the system ➞ Smart Function Kit for Handling "Software" instructions.

## 11 Maintenance and care

### 11.1 Maintenance and repair

- ▶ Repairs to the linear axis should only be performed by Bosch Rexroth.
- ▶ Maintenance is limited to re-lubrication. ➞ Notes in the instructions for the individual axes.
- ▶ Check all plug and clamping connections of the components at least once a year for proper fit and damage.
- ▶ Check possible cable breaks and crushed lines.
- ▶ Damaged parts must be exchanged immediately.

### 11.2 Lubrication

The system comes with initial greasing.

Observe the instructions in the product manual "Multi-axis systems R320103109".

## 12 Disposal

### 12.1 Return

Products manufactured by us can be returned free-of-charge for disposal. However, a prerequisite for this is that there are no objectionable films such as oil, grease or other contamination on the device. Moreover, the device must be free of inordinate foreign materials and / or components.

Please send the products carriage paid to the following address:

Bosch Rexroth AG  
Linear Motion Technologies  
Ernst-Sachs-Straße 100  
97424 Schweinfurt

### 12.2 Packaging

Packaging materials consist of cardboard, wood, and expanded polystyrene. They can be easily recycled at any point of acceptance. For ecological reasons, please refrain from returning the packaging.

### 12.3 Product

The product and its components must be recycled correctly and in compliance with all applicable national and international guidelines and regulations. Collect any leaking lubricant and recycle it correctly.

### 12.4 Batteries and accumulators



Batteries and accumulators can be marked with this symbol. The symbol of the crossed-out waste bin on wheels indicates that batteries are to be collected separately. Within the EU, the end user is legally obliged to return used batteries. The relevant regulations must be observed outside of the validity of the EU Directive 2006/66/EC. Used batteries may contain toxic substances that can harm the environment or human health if not stored or disposed of properly. The batteries or accumulators contained in Rexroth products are to be properly disposed after use, according to the country-specific return systems.

### 12.5 Recycling

Due to the high metal content, the products can mostly be recycled. To achieve an optimum metal recovery, disassembly into individual assemblies is required.

The product contains a number of different materials: aluminum, steel, plastics, grease and possibly electronic components.

## **NOTICE**

**Environmentally hazardous materials can pollute the environment if not disposed of properly.**

Environmental pollution.

- ▶ Collect any leaking lubricant and recycle it correctly.
- ▶ The product and its components must be recycled correctly and in compliance with all applicable national and international guidelines and regulations.

## 13 Service and support

We have a dense global service network for fast and optimal support. Our experts will be happy to assist you in any way they can. You can reach us 24/7 – even on weekends and holidays.

### Service Germany

You can reach our service hotline and our service helpdesk under:

Phone: +49 9352 40 5060

Fax: +49 9352 18 4941

E-mail: [service.svc@boschrexroth.de](mailto:service.svc@boschrexroth.de)

Internet: <http://www.boschrexroth.com>

Supplementary notes on service, repair work

(e.g. delivery addresses) and training can be found on our website.

### Worldwide service

If you are located outside of Germany, please first contact your local service representative. For hotline numbers, please refer to the sales addresses online.

### Information preparation

We will be able to help you quickly and efficiently if you have the following information ready:

- A detailed description of the malfunction and conditions
- Information on the name plate of the affected product, particularly the type code and serial numbers
- Your contact information (phone and fax number and email address)

## 14 Operating conditions

Observe the information on the environmental and operating conditions as stated in the product catalogs. Otherwise, a function and safety warranty cannot be assumed generally. For special environmental conditions, please consult us.

**Tabelle 17: Operating conditions mechanical system**

Operating conditions	Value
Ambient temperature with Bosch Rexroth servo motor	0 °C ... 40 °C, above 40 °C loss of performance
Ambient temperature for mechanical system (without dropping below dew point)	-10 °C ... 60 °
Soiling	Not permissible

**Tabelle 18: Operating conditions ctrlX components**

Operating conditions	Symbol	Unit	Value
Conductive contamination			Not permissible (Conductive contamination may be prevented e.g. by installation of the devices in control cabinets of enclosure protection class IP54 according to IEC529)
Enclosure protection class (IEC529)			IP20
Use within the scope of application of CSA / UL			Only approved for use in NFPA 79 applications.
Installation height	$h_{nenn}$	m	1000
Ambient temperature	$T_{a, work}$	°C	0 ... 40

## 14.1 Tightening torques

We use screws in the 8.8 strength class as standard. Any deviations are marked accordingly.

**Tabelle 19: Tightening torques**

 $\mu = 0.125$	Hex socket head cap screws according to ISO 4762, DIN 6912 and DIN 7984													
	M1.6	M2	M2.5	M3	M4	M5	M6	M8	M10	M12	M14	M16	M20	M24
<b>8.8</b> $\otimes$ $M_{A \max}$ (Nm)	0.17	0.4	0.70	1.3	2.8	5.5	9.6	23	46	80	127	194	392	675
<b>10.9</b> $\otimes$ $M_{A \max}$ (Nm)	0.24	0.5	1.00	1.8	4.0	8.1	14.0	34	68	116	186	285	558	960
<b>12.9</b> $\otimes$ $M_{A \max}$ (Nm)	0.29	0.6	1.25	2.1	4.8	9.5	16.5	40	80	137	218	333	653	1125



Bosch Rexroth AG  
Ernst-Sachs-Straße 100  
97424 Schweinfurt,  
Germany  
Tel. +49 9721 937-0  
Fax +49 9721 937-275  
[www.boschrexroth.com](http://www.boschrexroth.com)

Subject to modifications

Only available as PDF  
R320103224/2022-04