

Operating unit

TS-EC-E-SVAI; TS-EC-G-CR-SVAI;
TS-EC-E-CR; TS-EC-G-CR

Operating instruction
R901524148 / 09.2019

Replaces: DCA-EN_000165
English

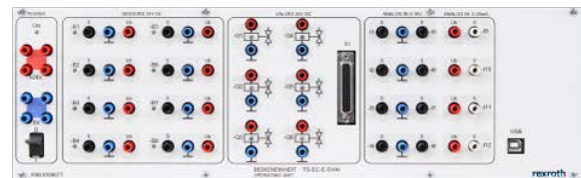
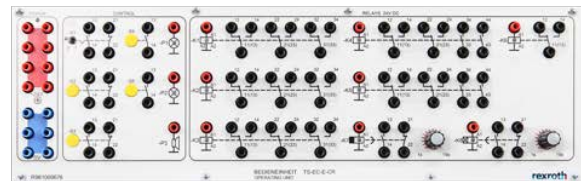

The data specified above only serve to describe the product. No statements concerning a certain condition or suitability for a certain application can be derived from our information. The information given does not release the user from the obligation of own judgment and verification. It must be remembered that our products are subject to a natural process of wear and aging.

This document, as well as the data, specifications and other information set forth in it, are the exclusive property of Bosch Rexroth AG. It may not be reproduced or given to third parties without its consent.

The cover page shows an example configuration. The product supplied may therefore differ from the figure.

The original operating instructions were prepared in German.

Contents

1	ABOUT THIS DOCUMENTATION.....	5
1.1	Validity of the documentation.....	5
1.2	Required and supplementary documentation.....	5
1.3	Illustration of information.....	6
1.4	Safety instructions.....	6
1.4.1	Symbols.....	7
1.4.2	Abbreviations.....	7
2	SAFETY INSTRUCTIONS.....	9
2.1	General information on this chapter.....	9
2.2	Intended use.....	9
2.3	Improper use.....	9
2.4	Qualification of personnel.....	10
2.4.1	Teaching.....	10
2.4.2	Troubleshooting, maintenance and repair.....	10
2.5	General safety instructions.....	10
2.6	Product- and technology-dependent safety instructions.....	11
2.6.1	Introduction.....	11
2.6.2	General.....	11
2.6.3	Danger due to incorrect use.....	12
2.6.4	Danger through manipulation.....	12
2.7	Personal protective equipment.....	12
2.8	Obligations of the operator.....	12
2.9	Safety Devices.....	12
3	GENERAL INFORMATION ON PROPERTY DAMAGE AND PRODUCT DAMAGE.....	13
4	SCOPE OF DELIVERY.....	15
4.1	TS-EC-G-CR operating unit (housing variant).....	15
4.2	TS-EC-G-CR-SVAI operating unit (housing variant).....	16
4.3	TS-EC-E-CR operating unit (19" Variant).....	16
4.4	TS-EC-E-SVAI operating unit (19" Variant).....	17
5	ABOUT THIS PRODUCT.....	19
5.1	Performance specification.....	19
5.2	Product description.....	19
5.2.1	TS-EC-G-CR operation unit (housing variant).....	20
5.2.2	TS-EC-G-CR-SVAI operation unit (housing variant).....	24
5.2.3	TS-EC-E-CR operation unit (19" Variant).....	32
5.2.4	TS-EC-E-SVAI operation unit (19" Variant).....	32
5.3	Identification and nameplate.....	33
6	TRANSPORT UND STORAGE.....	35
6.1	Dimensions.....	35
6.2	Transport.....	36
6.3	Storage.....	36
7	ASSEMBLY.....	37
7.1	General.....	37
7.2	Unpack your training system.....	37
7.3	Required tool.....	37
7.4	Mounting housing variants on workstation WS200.....	38
7.5	Mounting housing variants on workstation WS201.....	40
7.6	Expansion of housing variant TS-EC-G-CR.....	41
7.7	Mounting 19" Variant TS-EC-E-CR.....	43
7.8	Mounting 19" Variant TS-EC-E-SVAI.....	45
7.8.1	Mounting in connection with operating unit TS-EC-E-CR & WS290.....	45
7.8.2	Mounting in connection with operating unit TS-EC-G-CR.....	46
8	COMMISSIONING.....	47
8.1	Initial Commissioning.....	47
8.2	Putting back into operation after a longer standstill.....	47

9	OPERATION	49
9.1	Practical exercise	49
9.1.1	Representation of electrical circuits.....	49
9.2	Operation of the TS-***-SVAI operating units.....	51
9.2.1	Installing the Software.....	51
9.2.2	Connecting the OPC Software to Automation Studio	54
10	MAINTENANCE AND REPAIR	59
10.1	Maintenance	59
11	DISASSEMBLY REPLACEMENT	61
12	DISPOSAL	63
13	EXTENSION AND RECONSTRUCTION	65
14	TROUBLESHOOTING AND DEBUGGING	67
15	TECHNICAL DATA	69
15.1	Operating unit TS-EC-G-CR (housing variant)	69
15.2	Operation unit TS-EC-G-CR-SVAI (housing variant)	70
15.3	Operation unit TS-EC-E-CR (19" Variant)	71
15.4	Operation unit TS-EC-E-SVAI (19" Variant)	72
16	APPENDIX	73
16.1	List of addresses	73
16.2	Declaration of conformity for TS-EC-G-CR	74
16.3	Declaration of conformity for TS-EC-G-CR-SVAI	75
17	INDEX	77

1 About this documentation

1.1 Validity of the documentation

This document applies to the following products:

Operation Unit TS-EC-E-SVAI; TS-EC-G-CR-SVAI; TS-EC-E-CR; TS-EC-G-CR.

The following documentation uses the colloquial term control unit for the TS-EC-E-SVAI, TS-EC-G-CR-SVAI, TS-EC-E-CR, and TS-EC-G-CR operation unit.

This documentation is intended for trainers, training participants, operators and the plant operator.

These operating instructions contain important information on how to transport, commission, operate, use and maintain the control unit safely and properly and how to eliminate simple faults yourself.

- ▶ Please read this documentation completely and especially chapter 2 before working with the product.

1.2 Required and supplementary documentation

The following additional documentation is listed for these products.

Titel	Dokumentnummer	Dokumentart
Automation Studio Famic Technologies Inc. Bezug: https://www.famictech.com/de/support/		Online manual
Automation Studio Famic Technologies Inc. Bezug: https://www.famictech.com/de/support/		Installation guide
Workstation WS200	DCA-DE_000151	* Instruction manual
Hydraulic training system WS290 (DS4)	RD00225-B	* Instruction manual

Table 1: Required and supplementary documentation



You will find these *operating instructions as well as further documentation and data sheets in the Rexroth media directory at www.boschrexroth.com/variou utilities/mediadirectory

1.3 Illustration of information

Uniform safety instructions, symbols, terms and abbreviations are used so that you can quickly and safely work with your product using this documentation. For better understanding, they are explained in the following sections.

1.4 Safety instructions

In this documentation, safety instructions are included in chapter 2.6 and in chapter 3 and whenever sequences of actions or instructions are explained which bear the danger of personal injury or damage to property.

The measures described for the hazard avoidance must be observed

Safety instructions are set out as follows:

 SIGNAL WORD	
Type and source of danger	
Consequences of non-compliance	
▶	Hazard avoidance measures
▶	Enumeration

- **Warning sign:** Draws attention to the danger
- **Signal word:** Identifies the degree of danger
- **Type and source of danger:** Specifies the type and source of danger
- **Consequences:** Describes the consequences of non-compliance
- **Precautions:** Specifies how the danger can be prevented



Warning sign, signal word		Meaning of the risk class
	DANGER	Indicates a dangerous situation which may cause death or severe personal injuries if not avoided.
	WARNING	Indicates a dangerous situation which may cause death or severe personal injuries if not avoided.
	CAUTION	Indicates a dangerous situation which may cause minor to medium personal injuries if not avoided.
NOTICE		Indicates damage to property: The product or the environment could be damaged.

Table 2: Risk classes according to ANSI Z535.6-2006

1.4.1 Symbols

The following symbols indicate notes which are not safety-relevant but increase the comprehensibility of the documentation.





Symbol	Meaning
	If this information is not observed, the product cannot be optimally used and/or operated.
	Tip, general information, useful additional information
	Single, independent action step
	Enumeration
1. 2. 3.	Numbered instruction: The numbers indicate that the action steps follow each other.

Table 3: Meaning of the symbols

1.4.2 Abbreviations

The following abbreviations are used in this documentation:

Abbreviation	Meaning
BR	Bosch Rexroth
WS200	Workstation WS200
WS201	Workstation WS201
WS290	Workstation WS290

Table 4: Abbreviations

2 Safety instructions

2.1 General information on this chapter

The control units have been manufactured in accordance with the generally accepted rules of technology. Nevertheless, there is a risk of personal injury and damage to property if you do not observe this chapter and the safety instructions in this documentation.

- ▶ Read this documentation completely and thoroughly before working with the Operation Unit
- ▶ Keep this documentation in a location where it is accessible to all users at all times.
- ▶ Always include the required documentation when you pass the Operation Unit on to third parties

2.2 Intended use

The control unit is intended for use in technical training and further education in order to impart knowledge and skills for controlling electrohydraulic or electro-pneumatic systems.

Operation is only permitted under the operating conditions specified in chapter 15. The product is intended for educational and commercial use only and not for private use.

Intended use also includes that you operate the TS-EC-E-CR operating unit only in conjunction with the adapter plate R901384795 (not included in the scope of delivery).

The intended use also includes that you have read and understood this documentation and in particular chapter 2 and chapter 3 completely.

2.3 Improper use

Any other use than described in the intended use is not intended and therefore not permitted.

Bosch Rexroth AG accepts no liability for damage caused by improper use. The risks associated with improper use lie solely with the user.

Improper use includes non-compliance with the technical data, operating conditions, performance limits and environmental conditions specified in chapter 15.

2.4 Qualification of personnel

2.4.1 Teaching

Learners and trainees may only work with the training system

- under direct supervision,
- under the appropriate guidance of an instructor or trained personnel.

Trainer The trainer at the training system must be a skilled and qualified expert having experience in the field to be taught.

Trained personnel For the supervision during the exercises, trained personnel may also be used. These are qualified people who were instructed and briefed in relation to:

- tasks ordered,
- possible dangers in the event of improper use,
- safeguards and protective measures.

2.4.2 Troubleshooting, maintenance and repair

Maintenance, repair, troubleshooting and troubleshooting require special knowledge and may only be carried out by trained specialists!

Work on the electrical equipment may only be carried out by a qualified electrician. A skilled electrician is someone who is able to assess the work assigned to him, recognize possible dangers and take suitable safety measures on the basis of his technical training and experience as well as his knowledge of the relevant regulations.



The Bosch Rexroth AG offers measures supporting the training. An overview of the training contents is available online at:

<http://www.boschrexroth.com/de/de/training/training>

2.5 General safety instructions

- Observe the valid regulations for accident prevention and environmental protection.
- Observe the safety rules and regulations of the country in which the product is used.
- Only use Rexroth products in technically perfect condition.
- Observe all instructions on the product.
- Persons assembling, operating, disassembling or servicing Rexroth products must not be under the influence of alcohol, other drugs or medications which influence their reactivity.
- Only use accessories and spare parts approved by the manufacturer in order to exclude personal hazards due to unsuitable spare parts.
- Observe the technical data and environmental conditions specified in the product documentation.
- If unsuitable products are installed or used in safety-relevant applications, unintentional operating conditions may occur in the application which may cause personal injury and/or damage to property. Therefore, only use a product in safety-relevant applications if this use is expressly specified and permitted in the documentation of the product.

2.6 Product- and technology-dependent safety instructions

2.6.1 Introduction

The following instructions must be read before the system is put into operation for the first time to prevent personal injury and/or damage to property.

These safety instructions must be observed at all times.

Do not attempt to install or commission the control unit or the components it contains until you have carefully read through all the documents supplied. If no user instructions are available, contact your Bosch Rexroth Service Partner. This documentation must also be provided with the product if it is sold, rented and/or passed on in any other way.



Improper handling of this device and non-observance of the warnings given here as well as improper interventions in the safety equipment can lead to property damage, bodily injury, electric shock or, in extreme cases, death.

2.6.2 General

- Bosch Rexroth AG accepts no liability for damage resulting from non-compliance with the warnings in these operating instructions.
- The operating, maintenance and safety instructions must be read through before commissioning. If the documentation cannot be understood correctly in this language, contact your Bosch Rexroth Service Partner.
- The correct and safe operation of this device requires proper and professional transport, storage, assembly and installation as well as careful operation and maintenance.
- Only trained and qualified personnel may be used to handle and train electrical equipment. The personnel are qualified if they are sufficiently familiar with the assembly, installation and operation of the product as well as with all warnings and precautions according to these operating instructions.
- Only accessories and spare parts approved by Bosch Rexroth may be used.
- The safety regulations and provisions of the country in which the device is used must be observed.
- The ambient conditions specified in the product documentation must be observed.
- Commissioning is prohibited until it has been established that the control unit complies with the country-specific regulations, safety regulations and standards.
- The technical data, the connection and installation conditions can be found in the product documentation and must be observed

2.6.3 Danger due to incorrect use

 CAUTION
Risk of injury due to improper handling! Physical injury due to crushing, shearing, cutting, impact!

2.6.4 Danger through manipulation

 WARNING
Manipulated and/or non-functioning safety and protective devices! Danger to life!

2.7 Personal protective equipment

The personal protective equipment for users of the control unit consists of:

- Safety shoe

All components of personal protective equipment must be intact.

2.8 Obligations of the operator

In order to ensure safety when handling the control unit, the operator of the system must:

- ▶ ensure that the operating unit and its components are used as intended, as described in chapter 2.2.
- ▶ regularly instruct the operating personnel in all points of the operating instructions and ensure that they are observed
- ▶ ensure compliance with accident prevention regulations (UVV)
- ▶ ensure compliance with the specified operating data

The operator must regularly train his personnel on the following topics:

- ▶ Observance and use of the operating instructions and the statutory provisions
- ▶ Intended operation
- ▶ Observance of the instructions of the factory security and the operating instructions of the operator
- ▶ Behaviour in an emergency

2.9 Safety Devices

For the protection of persons, the operating units are equipped with a safety extra-low voltage operated by 24V DC

3 General information on property damage and product damage



The warranty applies exclusively to the delivered configuration.

The warranty claim expires in case of faulty assembly, commissioning and operation as well as in case of improper use and / or improper handling.

NOTES

Danger due to improper handling!

Damage to property!

Product may only be used according to chapter 2.2.

4 Scope of delivery

4.1 TS-EC-G-CR operating unit (housing variant)

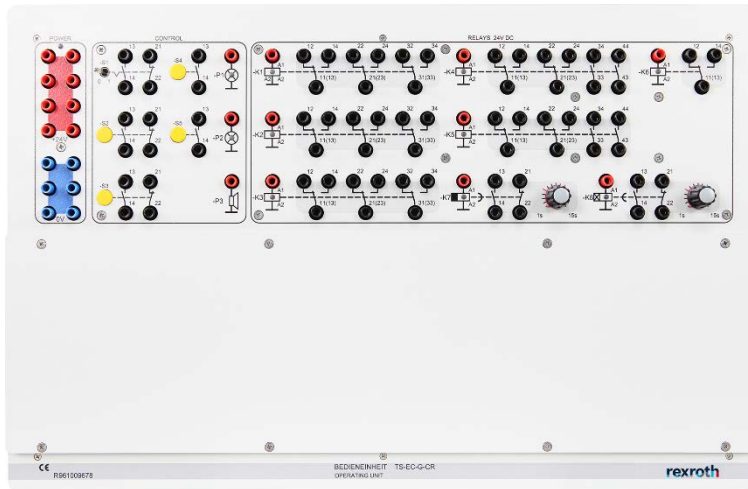

Figure 1: TS-EC-G-CR operating unit (housing variant)

The control unit can be ordered under the material number R961009678.

Included in the scope of delivery:

Quantity	Description
1	TS-EC-G-CR operating unit (housing variant) The mounting bracket with 2 cheese head screws, 2 washers and 2 sliding blocks is loosely mounted on the rear side
1	These operating instructions
1	Mains connection cable with safety plug and socket (230VAC, 10A)
1	T-nut M5 (for mounting on WS200 with grooved plate)

Table 5: Scope of delivery TS-EC-G-CR

4.2 TS-EC-G-CR-SVAI operating unit (housing variant)



Figure 2: TS-EC-G-CR-SVAI operating unit (housing variant)

The control unit can be ordered under the material number R961009675.

Included in the scope of delivery:

Quantity	Description
1	TS-EC-G-CR operating unit (housing variant) The mounting bracket with 2 cheese head screws, 2 washers and 2 sliding blocks is loosely mounted on the rear side
1	These operating instructions
1	Mains connection cable with safety plug and socket (230VAC, 10A)
1	USB Cable (Connection to PC or Laptop)
1	Data carrier with OPC server software
1	T-nut M5 (for mounting on WS200 with grooved plate)

Table 6: Scope of delivery TS-EC-G-CR-SVAI

4.3 TS-EC-E-CR operating unit (19" Variant)

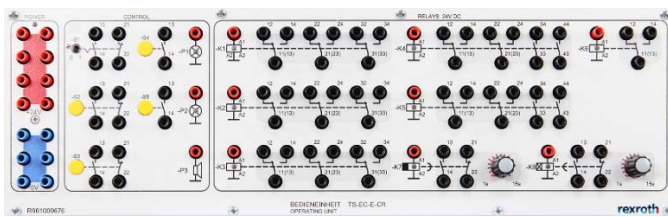

Figure 3: TS-EC-E-CR operating unit (19" Variante)

The control unit can be ordered under the material number R961009676.

Included in the scope of delivery:

Quantity	Description
1	TS-EC-E-CR operating unit (19" Variant)
1	These operating instructions
8	Fixing screw with plastic nipple

Table 7: Scope of delivery TS-EC-E-CR

4.4 TS-EC-E-SVAI operating unit (19" Variant)

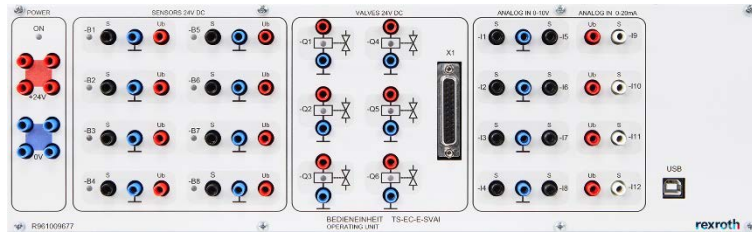

Figure 4: TS-EC-E-SVAI operating unit (19" Variant)

The control unit can be ordered under the material number R961009677.

Included in the scope of delivery:

Quantity	Description
1	TS-EC-E-SVAI operating unit (19" Variant)
1	These operating instructions
1	USB Cable (Connection to PC or Laptop)
1	Data carrier with OPC server software
8	Fixing screw with plastic nipple

Table 8: Scope of delivery TS-EC-E-SVAI

5 About this product

5.1 Performance specification

This chapter describes the different types of Bosch Rexroth operation units. The variants with the type designation TS-EC-G-CR-SVAI and TS-EC-E-SVAI also offer the possibility of connection-programmed controls from the electrohydraulics / electropneumatics and electrical engineering sectors using a PC and corresponding software (Automation Studio). These control units are equipped with corresponding EA modules for this purpose. For details see chapters 5.2.2 and 5.2.4.

5.2 Product description

The following chapter describes the different types of operation units.

To protect the printed circuit boards, the 24V DC operating voltage of all control units is protected by a fuse. The fuse is soldered directly onto the printed circuit board and therefore cannot be changed without effort. The fuse protection is 4A MT.



A power supply of the operating units via the front side (Power, 0V) is not permitted, as the circuit board protection by the circuit board fuse does not function here.

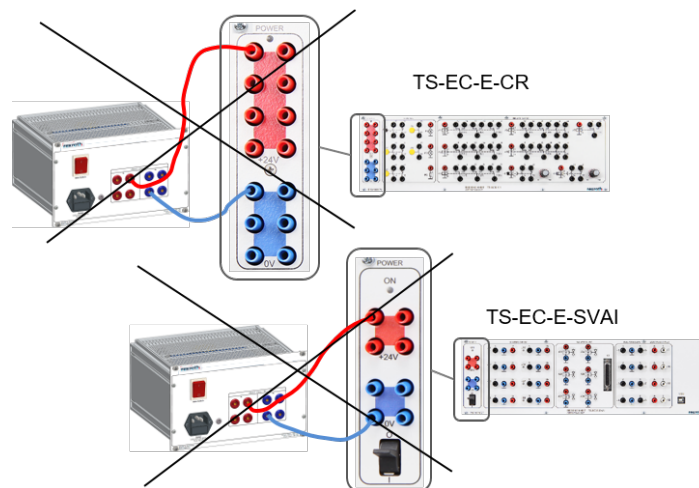

Figure 5: External power supply

5.2.1 TS-EC-G-CR operation unit (housing variant)

This control unit is a multifunctional electrical module for implementation of project exercises with electrical control.

The housing variant is designed for attachment to the workstation WS200 or WS201.

Information on mounting can be found in chapter 7.

In this operating unit, the required function modules such as power supply, operating and display elements, relays and relay contacts are arranged in a compact form on a common front panel.

Electrical circuits can be quickly and effectively assembled and wired using safety connection sockets on the front panel, whose functions are clearly identified by standardized symbols and designations.

The electrical connection is made via a IEC plug with on/off switch on the top of the console housing. The mains connection cable required for this is included in the scope of delivery. To generate the 24V DC operating voltage, a power supply unit (100- 230V /24V DC, 5A) is installed in the control unit.



- 1 ON/OFF switch
- 2 IEC plug (C14)

Figure 6: Power supply - TS-EC-G-CR

A blind plate is mounted below the function modules "POWER", "CONTROL" and "RELAYS". This can be removed to expand the TS-EC-G-CR operating unit and equipped with the TS-EC-E-SVAI operating unit (19" variant), for example. Details can be found in chapter 7.



Figure 7: TS-EC-G-CR operation unit (housing variant)

The following illustrations give an overview of the function groups "POWER", "CONTROL" and "RELAYS" on the front of the operating unit.

Function module „POWER“

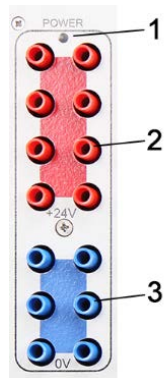

- 1 The LED signals that the 24V DC operating voltage is available.
- 2 Supply of 24V DC operating voltage via 8 safety laboratory sockets (4mm)
- 3 Supply of 0V operating voltage via 6 safety laboratory sockets (4mm)

Figure 8: Function module "POWER"

The "POWER" function module provides the 24V DC operating voltage for wiring the "CONTROL" and "RELAYS" function modules. For the circuit design and the wiring of the respective modules, 4mm safety measuring cables are used.



Make sure that the maximum output current of the 24V DC operating voltage of 4 A DC must not be exceeded via the "POWER" function module.

Function module „CONTROL“

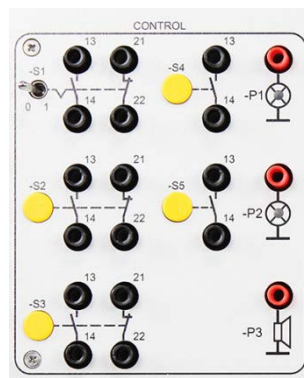

Figure 9: Function module "CONTROL"

Various switches, push-buttons, LEDs and a buzzer are available in the "CONTROL" function module for circuit design and wiring. Relays or actuators, for example, can be electrically energised via switches and push-buttons. The LEDs and the buzzer can be used, for example, to signal the switching status of the relay outputs. The circuit design and the wiring are carried out by 4mm safety measuring cables (not included in delivery).

The following table describes the properties of the switches, buttons, LED's and buzzer used.

Designation	Function
S1	Switch with latching position (1 NC contact, 1 NO contact)
S2, S3	Pushbutton with impulse contact (1 NC contact, 1 NO contact)
S4, S5	Pushbutton with impulse contact (1 NO contact)
P1, P2	LED status display (+24V DC); ground connection (0V) is internal.
P3	Acoustic alarm (+24V DC); Ground connection (0V) is internal.

Table 9: Operating and signalling elements

Function modul „RELAYS“

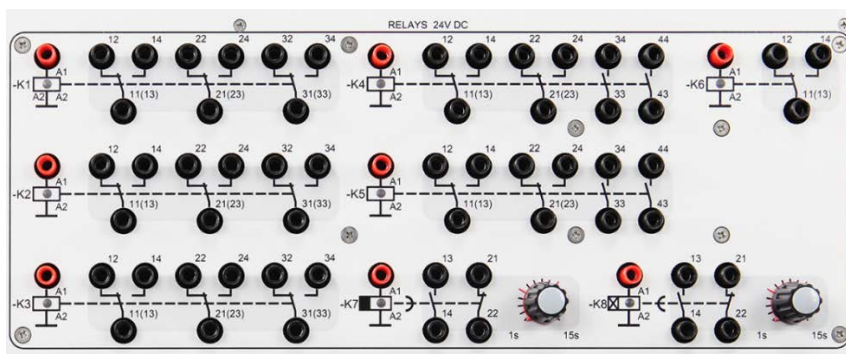

Figure 10: Function modul „RELAYS“

Various relays are available in the "RELAYS" function module for circuit design and wiring. The 24V DC relays "K1 to K6" distinguish by the number of contacts.

The 24V DC relay "K8" offers the possibility of mapping Circuits with on-delayed switching operations. The on-delayed-switching can be set continuously from 1-15 seconds via the potentiometer on the side.

The 24V DC relay "K7" offers the possibility to map circuits with off-delayed-switching. The drop-out delay can be set continuously from 1-15 seconds via the potentiometer on the side.

For all relays, the status of the respective relay coil is indicated by an LED arranged in the switching symbol. In order to optimise the wiring structure and to ensure a better overview of the circuit, the contacts "A2" of the relay coils are already intensely wired to ground (0V DC).

The following table describes the properties of the relay types used.

Designation	Function
K1, K2, K3	24V DC relay (3 changeover contacts each, 24V DC, max. 2,5A)
K4, K5	24V DC relay (2 changeover contacts each, 2 NO 24V DC, max. 2,5A)
K6	24V DC relay (1 changeover contact, 24V DC, max. 2,5A)
K7	24V DC relay with adjustable off delay (1 changeover)
K8	24V DC relay with adjustable on delay (1 changeover)

Table 10: Properties of the relays in the "RELAYS" function module

Extension option

The functional range of the TS-EC-G-CR operating unit can be extended by retrofitting the TS-EC-E-SVAI operating unit (19" variant). For this purpose, the blind plate on the front panel of the TS-EC-G-CR operating unit must be removed and replaced by the TS-EC-E-SVAI operating unit. See the illustration below.

A detailed description of the installation and connection of the power supply can be found in chapter 7.8.2.



Figure 11: TS-EC-G-CR operating unit (housing variant) with extension by TS-EC-E-SVAI operating unit (19" variant)

5.2.2 TS-EC-G-CR-SVAI operation unit (housing variant)

This control unit is a multifunctional electrical module for implementation of project exercises with electrical control and simulation of this control.

The housing variant is designed for attachment to the workstation WS200 or WS201.

Information on mounting can be found in chapter 7.

In this operating unit, the required function modules such as power supply, operating and display elements, relays and relay contacts are arranged in a compact form on a common front panel.

Electrical circuits can be quickly and effectively assembled and wired using safety connection sockets on the front panel, whose functions are clearly identified by standardized symbols and designations.

The function modules in the lower part of the front panel are intended for use with simulation software (e.g. Automation Studio). Further information can be found in the further course of this chapter.

The electrical connection is made via a IEC plug with on/off switch on the top of the console housing. The mains connection cable required for this is included in the scope of delivery. To generate the 24V DC operating voltage, a power supply unit (100- 230V /24V DC, 5A) is installed in the control unit.



- 1 ON/OFF switch
- 2 IEC plug (C14)

Figure 12: Power supply - TS-EC-G-CR-SVAI



Figure 13: TS-EC-G-CR-SVAI operation unit (housing variant)

The following illustrations give an overview of the function groups "POWER", "CONTROL", "RELAYS", "SENSORS 24V DC", "VALVES 24V DC", "ANALOG IN 0-10V", "ANALOG IN 4-20mA" and USB on the front of the control unit.

Function module „POWER“

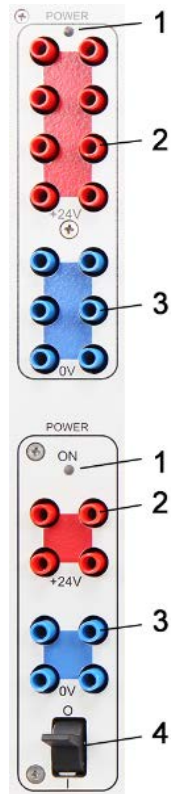

- 1 The LED signals that the 24V DC operating voltage is available.
- 2 Supply of 24V DC operating voltage via 12 safety laboratory sockets (4mm)
- 3 Supply of 0V operating voltage via 10 safety laboratory sockets (4mm)
- 4 The 24V DC operating voltage can be switched on via the toggle switch. The two LEDs "1" indicate the status of the switched-on 24V DC operating voltage.

Figure 14: Function module „POWER“

The "POWER" function module provides the 24V DC operating voltage for wiring the "CONTROL" and "RELAYS" function modules. For the circuit design and the wiring of the respective modules, 4mm safety measuring cables are used.



Make sure that the maximum output current of the 24V DC operating voltage of 4 A DC must not be exceeded via the "POWER" function module.

Function module „CONTROL“

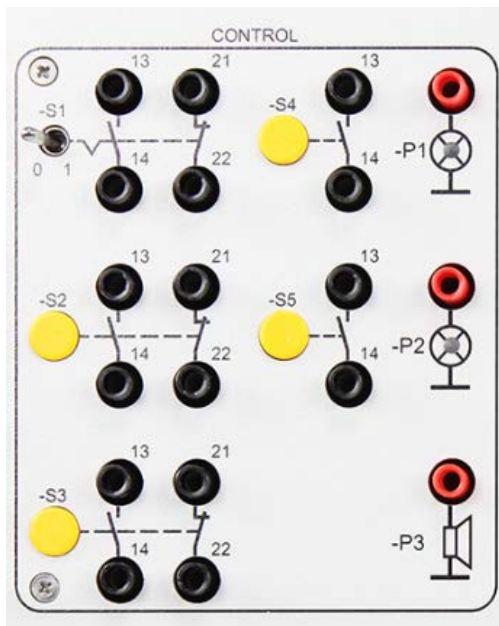

Figure 15: Function module "CONTROL"

Various switches, push-buttons, LEDs and a buzzer are available in the "CONTROL" function module for circuit design and wiring. Relays or actuators, for example, can be electrically energised via switches and push-buttons. The LEDs and the buzzer can be used, for example, to signal the switching status of the relay outputs. The circuit design and the wiring are carried out by 4mm safety measuring cables (not included in delivery).

The following table describes the properties of the switches, buttons, LED's and buzzer used.

Designation	Function
S1	Switch with latching position (1 NC contact, 1 NO contact)
S2, S3	Pushbutton with impulse contact (1 NC contact, 1 NO contact)
S4, S5	Pushbutton with impulse contact (1 NO contact)
P1, P2	LED status display (+24V DC); ground connection (0V) is internal.
P3	Acoustic alarm (+24V DC); Ground connection (0V) is internal.

Table 11: Operating and signalling elements

Function modul „RELAYS“



Figure 16: Function modul „RELAYS“

Various relays are available in the "RELAYS" function module for circuit design and wiring. The 24V DC relays "K1 to K6" distinguish by the number of contacts.

The 24V DC relay "K8" offers the possibility of mapping Circuits with on-delayed switching operations. The on-delayed-switching can be set continuously from 1-15 seconds via the potentiometer on the side.

The 24V DC relay "K7" offers the possibility to map circuits with off-delayed-switching. The drop-out delay can be set continuously from 1-15 seconds via the potentiometer on the side.

For all relays, the status of the respective relay coil is indicated by an LED arranged in the switching symbol. In order to optimise the wiring structure and to ensure a better overview of the circuit, the contacts "A2" of the relay coils are already intensely wired to ground (0V DC).

The following table describes the properties of the relay types used.

Designation	Function
K1, K2, K3	24V DC relay (3 changeover contacts each, 24V DC, max. 2,5A)
K4, K5	24V DC relay (2 changeover contacts each, 2 NO 24V DC, max. 2,5A)
K6	24V DC relay (1 changeover contact, 24V DC, max. 2,5A)
K7	24V DC relay with adjustable off delay (1 changeover)
K8	24V DC relay with adjustable on delay (1 changeover)

Table 12: Properties of the relays in the "RELAYS" function module

i In order to use the following function modules, a connection to a PC (via USB) with installed simulation software (Automation Studio) is additionally required. Further information can be found in chapter 9.

Function modul „SENSORS 24V DC“

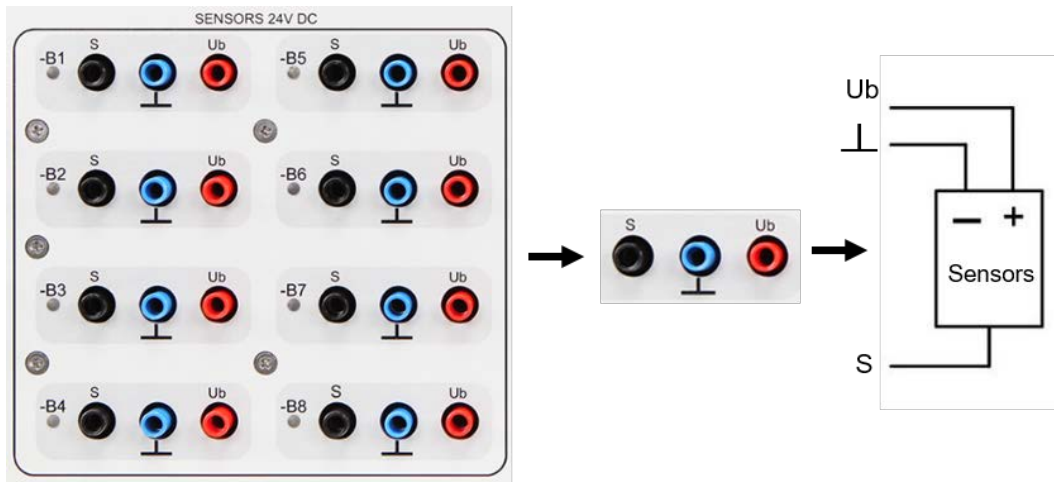

Figure 17: Function modul "SENSORS 24V DC"

The function module "SENSORS 24V DC" contains 8 digital inputs (B1-B8) with corresponding status LED. The LED lights up when the digital input is active.

The connection diagram is shown in the figure above.

The following components can be connected via 4mm safety sockets:

- hydraulic or pneumatic pressure switches
- electric limit switches
- electric temperature switches

The following table describes the properties

Designation	Function
S	Digital input (+ 24V DC)
	Ground (0V)
Ub	Power supply 24V DC

Table 13: Properties of the "SENSORS 24V DC" function module

Function modul „VALVES 24V DC“

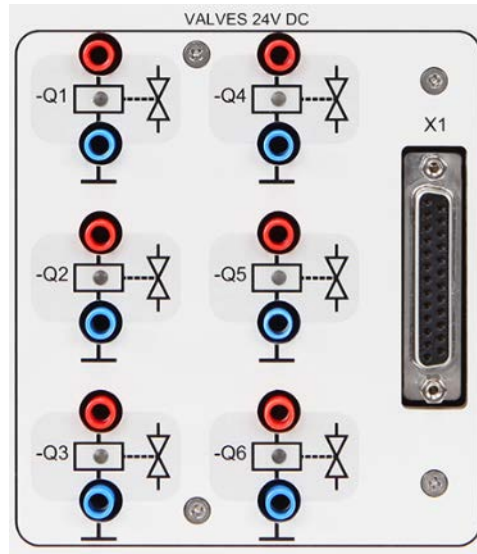

Figure 18: Function modul „VALVES 24V DC“

The function module "VALVES 24V DC" contains 6 digital outputs (Q1-Q6) with corresponding status LED. The LED lights up when the digital output is active.

A further 10 digital outputs are available via the D-Sub socket (X1).

Electrically operated switching valves can be connected via 4mm safety sockets.

The following table describes the properties

Designation	Function
Q1 bis Q6	red socket -> Digital output (+ 24V DC)
	blue socket -> \perp Ground (0V)
X1	Pin 1 -> Digital output Q7 (+ 24V DC)
	Pin 2 -> Digital output Q8 (+ 24V DC)
	Pin 3 -> Digital output Q9 (+ 24V DC)
	:: :: :: ::
	Pin 10 -> Digital output Q16 (+ 24V DC)
	Pin 11 to Pin 24 -> disconnected
Pin 25 -> \perp Ground (0V)	

Table 14: Properties of the "VALVES 24V DC" function module

Function modul „ANALOG IN 0-10V“

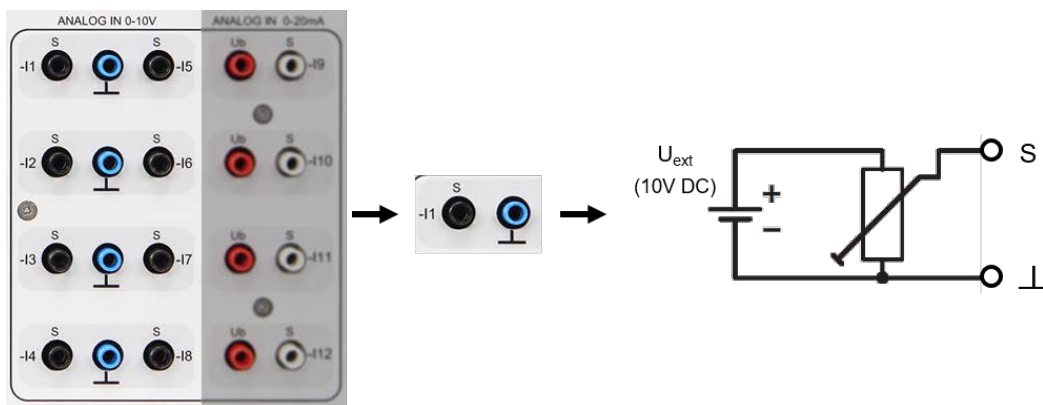

Figure 19: Function modul „ANALOG IN 0-10V“

The function module "ANALOG IN 0-10V" contains 8 analog voltage inputs (I1 to I8). Sensors with a measuring signal of 0-10V, e.g. potentiometer position sensors, can be connected via 4mm safety sockets. The connection diagram is shown in the figure above.

The following table describes the properties

Designation	Function
I1 bis I8	Analog input (0-10V)
	Masse (0V)

Table 15: Properties of the "ANALOG IN 0-10V" Function Module

Function modul „ANALOG IN 0-20mA“

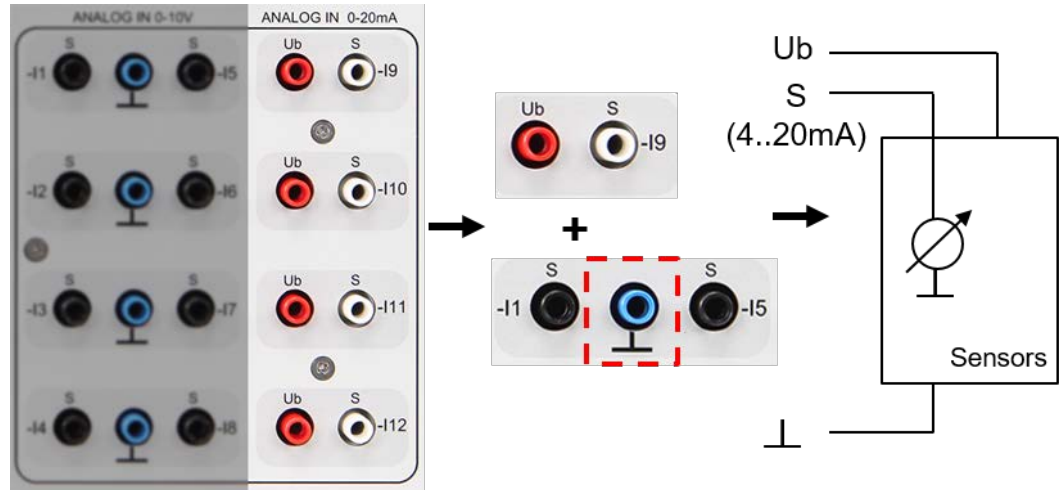

Figure 20: Function modul „ANALOG IN 0-20mA“

The function module "ANALOG IN 0-20mA" contains 4 analog current inputs (I9 to I12). Sensors with a measuring signal of 0-20mA, e.g. pressure or temperature sensors, can be connected via 4mm safety sockets. The connection diagram is shown in the figure above.

The following table describes the properties

Designation	Function
I9bis I12	Analog input (4-20mA)
Ub	Power supply (24V DC)
⊥	Ground (0V)

Table 16: Properties of the "ANALOG IN 0-20mA" Function Module

5.2.3 TS-EC-E-CR operation unit (19" Variant)

This operating unit is designed as a 19" variant and is mounted in the 19"-rack of the WS290 workstation.

The elements on the front panel of the operating unit correspond to the operating unit of the housing variant (TS-EC-G-CR).

A power supply unit (100-230V /24V DC, 5A) is installed on the rear. The power supply for this power supply unit must be provided via an external adapter plate (R901384795, not included in delivery).

Installation instructions and the electrical connection can be found in chapter 7 "Installation".

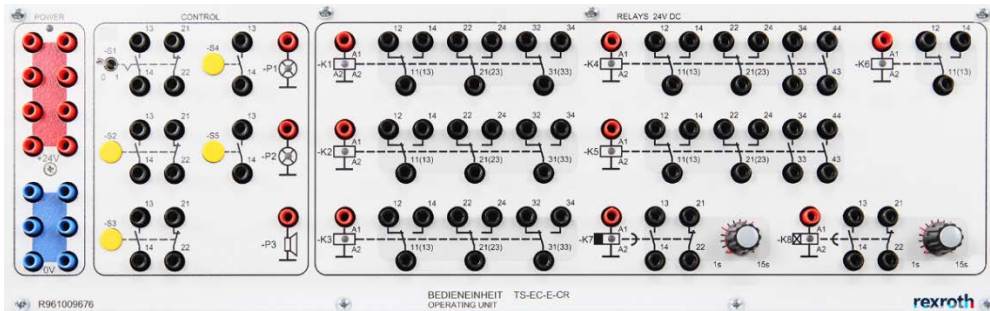

Figure 21: TS-EC-E-CR

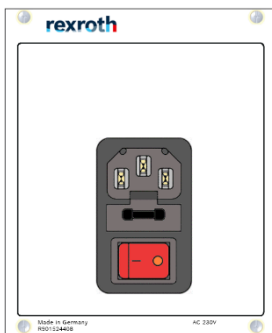

Figure 22: adapter plate, R901384795

5.2.4 TS-EC-E-SVAI operation unit (19" Variant)

This operating unit is designed as a 19" variant and is mounted in the 19"-rack of the WS290 workstation.

The elements on the front panel of this control unit correspond to the lower half of the front panel of the housing variant (TS-EC-G-CR-SVAI). However, only the supply voltage of this control unit can be switched on with the toggle switch. The supply voltage must be external.

Installation instructions and the electrical connection can be found in chapter 7 "Installation".

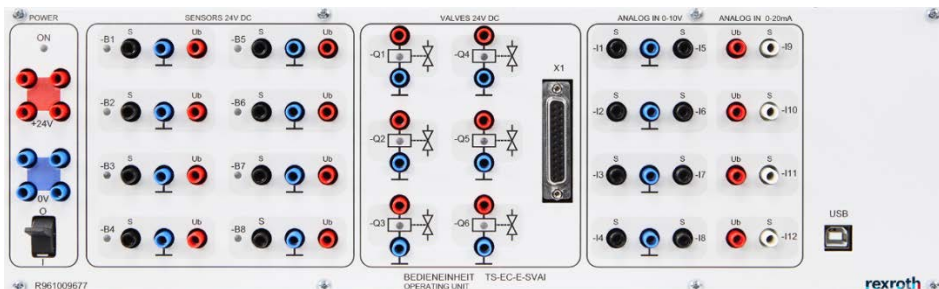
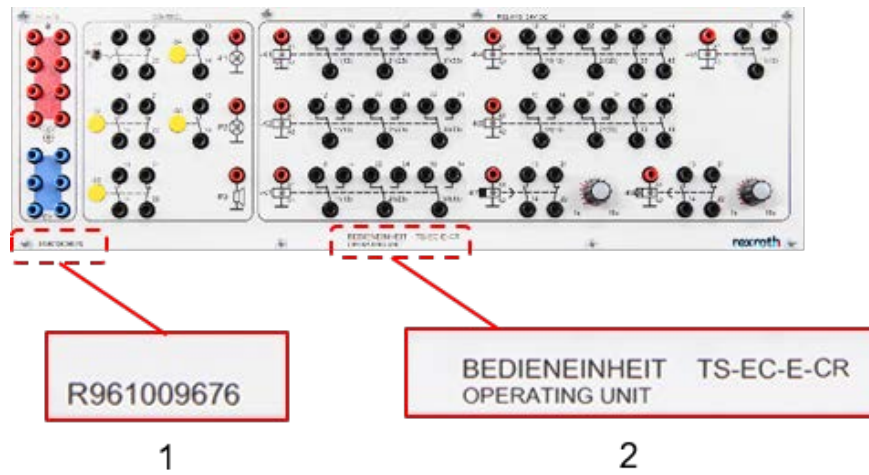

Figure 23: TS-EC-E-SVAI

5.3 Identification and nameplate

For identification purposes (e.g. when ordering spare parts), the material number is printed on the front panel of each control unit.

The following figure shows the position of the material number and the designation of the operating unit.



- 1 material number
- 2 designation

Figure 24: Identification

6 Transport und Storage

6.1 Dimensions

TS-EC-G-CR and TS-EC-G-CR-SVAI

The following view shows the dimensions of the housing variant TS-EC-G-CR. The housing variant TS-EC-G-CR-SVAI has the same dimensions as the TS-EC-G-CR-CR.

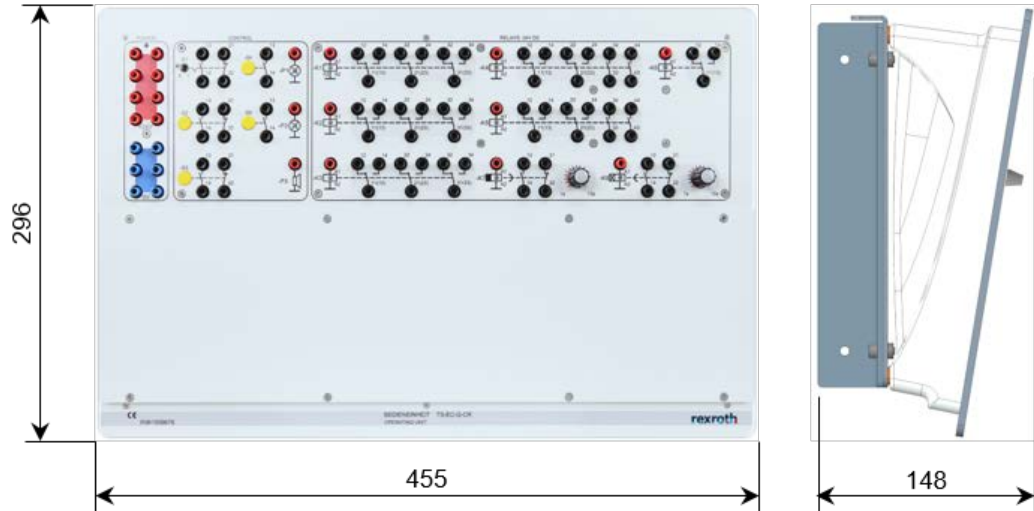

Figure 25: Dimensions (in mm)

TS-EC-E-CR und TS-EC-E-SVAI

The dimensions of the 19" variant TS-EC-E-CR are shown in the following view. The 19" variant TS-EC-E-SVAI has the same dimensions except for the depth (value in brackets).



Figure 26: Dimensions (in mm)

6.2 Transport

This is how you transport:

- ▶ Protect the operation unit against dust and moisture with appropriate packaging.
- ▶ Protect the control unit from strong temperature fluctuations, strong sunlight and strong cooling to prevent condensation.

Denomination	Unit	Value
temperature range	°C	0 to 40
humidity condensation		not permissible
icing		not permissible

Table 17: Terms of transport

6.3 Storage

Denomination	Unit	Value
Min. storage temperature	°C	0
Max. storage temperature	°C	+40
Relative Humidity	%	5 to 60, non-condensing

Table 18: Storage conditions

This is how you store:

- ▶ Protect the control unit against dust and moisture with appropriate packaging.
- ▶ Protect the control unit from strong temperature fluctuations, strong sunlight and strong cooling to prevent condensation.
- ▶ Store only in weather-protected areas.

7 Assembly

7.1 General

This chapter describes how to attach the housing variants to the WS200 and WS201 workstations and how to install the 19" variants in the 19"-rack.

The control units are generally mounted without connecting a supply voltage.

7.2 Unpack your training system

 CAUTION
<p>Danger of parts falling out! If the packaging is not opened properly, parts may fall out and become damaged. Damage or injury may result.</p> <ul style="list-style-type: none"> ▶ Place the packaging on a level, stable surface.

 CAUTION
<p>Risk of injury!</p> <ul style="list-style-type: none"> ▶ Lifting heavy parts can lead to back injuries.

 CAUTION
<p>Risk of injury! Sharp and pointed packaging parts can lead to injuries if handled improperly.</p> <ul style="list-style-type: none"> ▶ Open the packaging with suitable aids. ▶ Do not use sharp blades. Internal parts could be damaged!

Dispose of the packaging material in accordance with the national regulations of your country and your company-internal defaults.



Transport damage and defects must be recorded immediately with a photograph and reported in writing to Rexroth Customer Service together with a damage report.

7.3 Required tool

Designation	Width across flats (in mm)	Symbol
Allen key	5	

Table 19: For housing variants

Designation	Width across flats (in mm)	Symbol
Cross-headed screwdriver	PH 1	

Table 20: For 19" variants

7.4 Mounting housing variants on workstation WS200

Mounting on workstation WS200 with grid

Assembly steps:

- ▶ Remove the mounting bracket from the operation unit.
- ▶ Mount the mounting bracket on the operation unit with the mounting side facing outwards.
- ▶ Remove the cover cap from a strut of the WS200 workstation.
- ▶ Insert the sliding blocks of the operation unit from above into the outer groove of the strut of the workstation WS200.
- ▶ Position the operation unit vertically and fasten using the two screws.
- ▶ Reinstall the cover cap

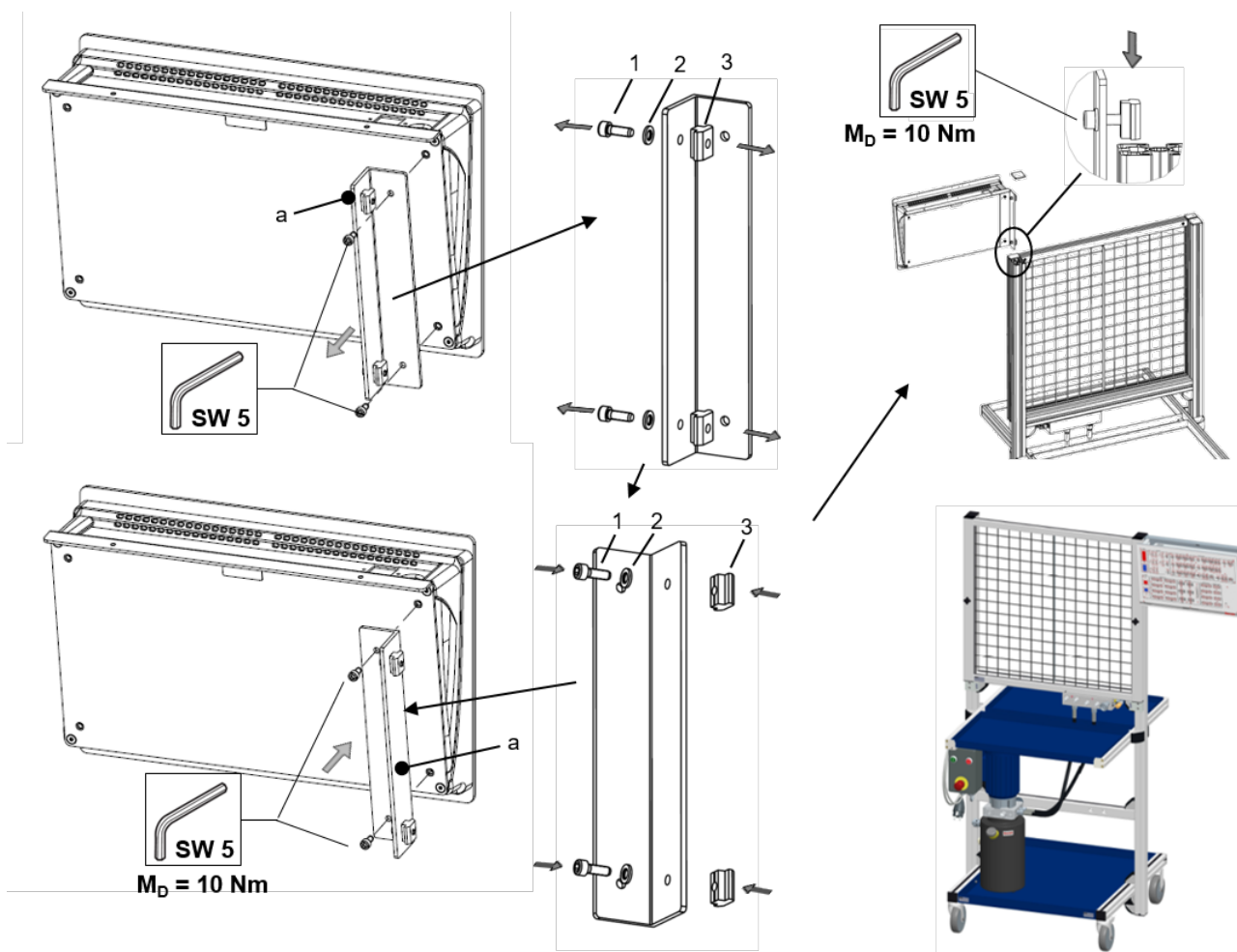

- 1 Socket head screw
- 2 Washer
- 3 Sliding block
- a fixing side

Figure 27: Mounting on workstation WS200 with grid



In the illustration, the operation unit is mounted on the right-hand side of the WS200 workstation. You can also mount the operation unit on the left side. To do this, the mounting bracket must be mounted on the other side of the operation unit. The remaining assembly steps are the same.

Mounting on workstation WS200 with grooved plate

Assembly steps:

- ▶ Remove the mounting bracket from the operation unit.
- ▶ Mount the mounting bracket on the operation unit with the mounting side facing outwards.
- ▶ Replace the lower sliding block with a T-nut (M5) included in the scope of delivery.
- ▶ Remove the cover cap from a strut of the WS200 workstation.
- ▶ Move the operation unit to the side of the strut until the T-nut is seated in the groove.
- ▶ Move the operation unit downwards until the upper sliding block is in the slot.
- ▶ Position the operation unit vertically and fasten it using the two screws.
- ▶ Reinstall the cover cap.

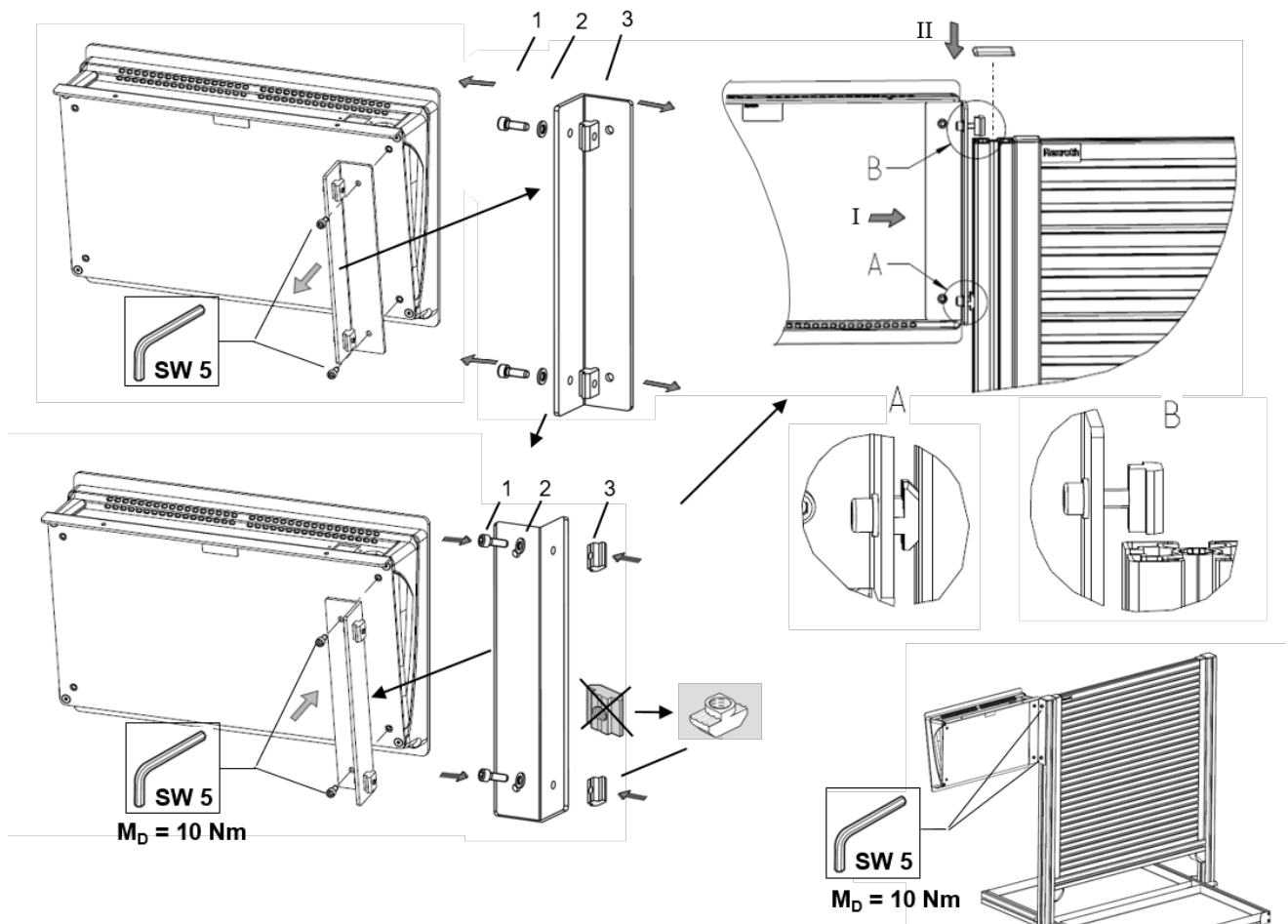

- 1 Socket head screw
- 2 Washer
- 3 Sliding block

Figure 28: Mounting on workstation WS200 with grooved plate



In the illustration, the operation unit is mounted on the right-hand side of the WS200 workstation. You can also mount the operation unit on the left side. To do this, the mounting bracket must be mounted on the other side of the operation unit. The remaining assembly steps are the same.

7.5 Mounting housing variants on workstation WS201

Assembly steps:

- ▶ Remove the cover cap from the left strut of the workstation WS201.
- ▶ Insert the sliding blocks of the operation unit from above into the outer groove of the strut of the workstation WS201.
- ▶ Move the operation unit downwards until there is enough space to remount the cover cap.
- ▶ Place the operation unit on the cover cap and fasten using the two screws.

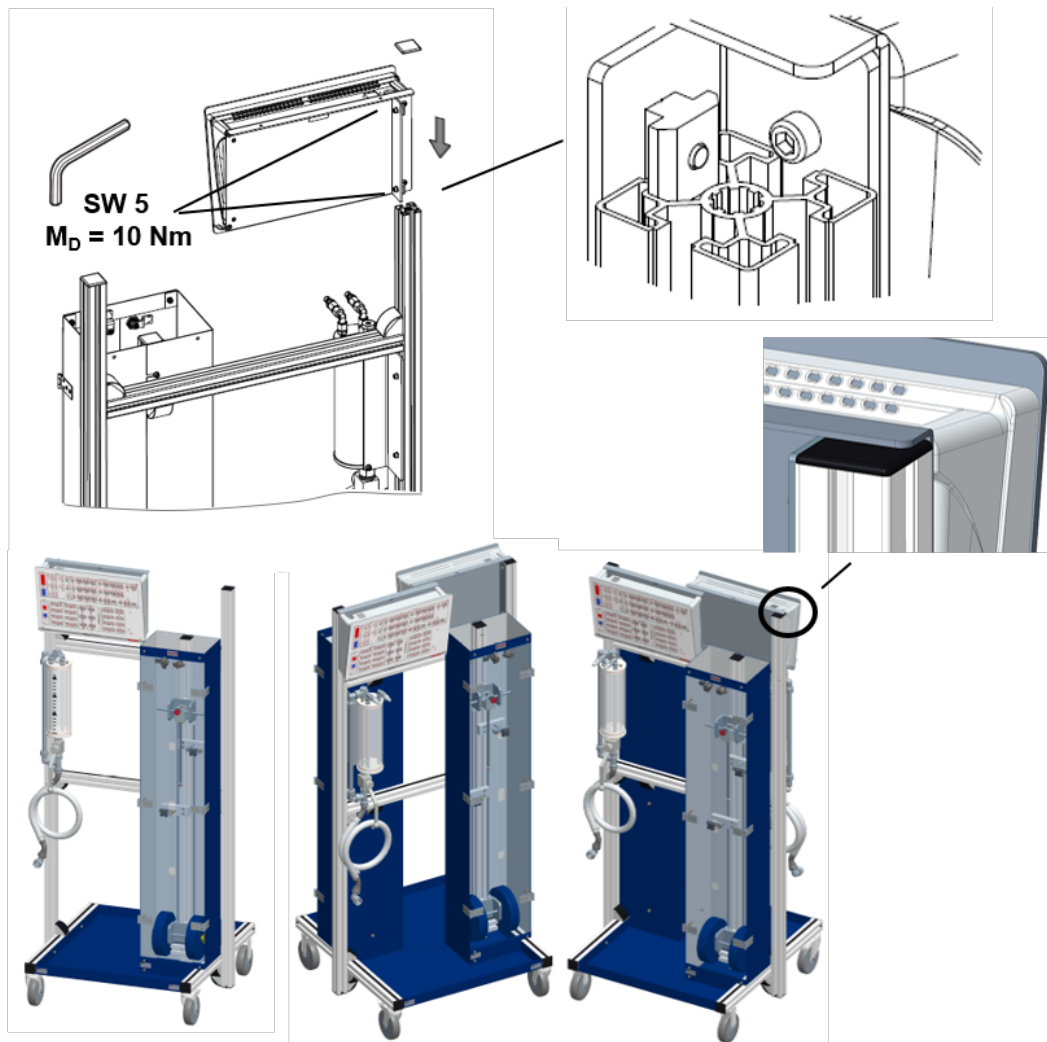

Figure 29: Mounting housing variants on WS201

7.6 Expansion of housing variant TS-EC-G-CR

The functional range of the TS-EC-G-CR operating unit can be extended by retrofitting the TS-EC-E-SVAI operating unit (19" variant). For this purpose, the blind plate on the front panel of the TS-EC-G-CR operating unit must be removed and replaced by the TS-EC-E-SVAI operating unit.

Power is supplied via the TS-EC-G-CR operating unit. For the electrical connection, the TS-EC-E-SVAI operating unit is already equipped with the required connection cables.



Carefully unscrew and reinsert the fixing screws, as this is a plastic housing.

Assembly steps:

- ▶ Remove the blind plate.
- ▶ Remove the front panel.
- ▶ Mount the TS-EC-E-SVAI operation unit in the place of the blind plate. Replace the fixing screws of the operation unit with the screws of the blind plate.
- ▶ Turn the front panel over. The printed circuit board with the plug contacts for the power supply is located on the rear side of the front panel.
- ▶ Plug the connector plugs of the two supply wires (black and red) into the corresponding slots (as pictured) on the circuit board of the TS-EC-G-CR operating unit.
- ▶ Mount the front panel. Make sure that no cables are squeezed during installation.

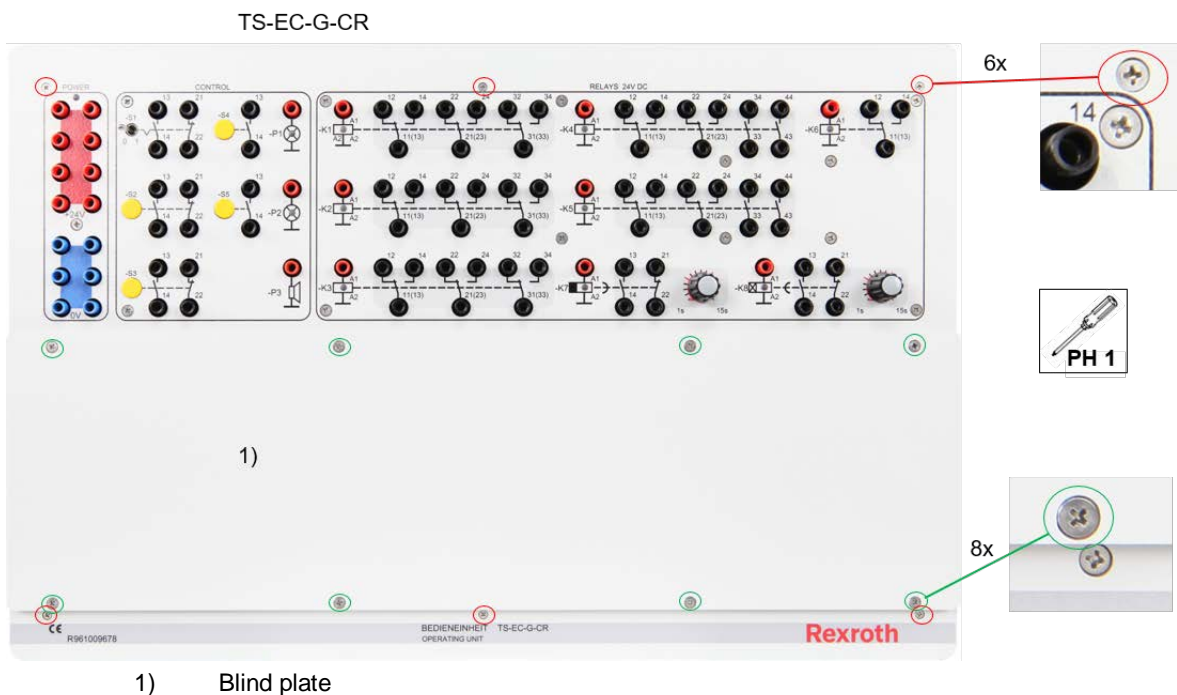

Figure 30: Overview of fastening screws

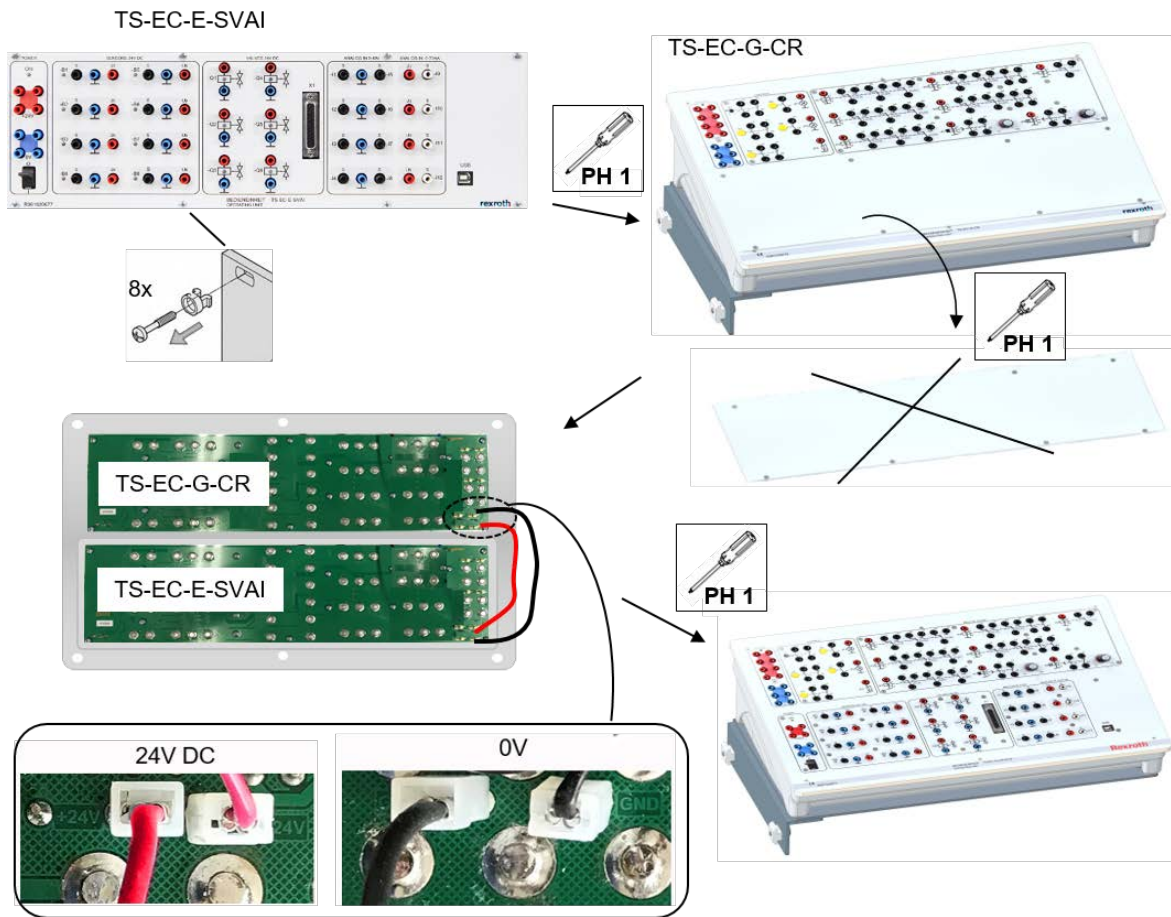

Figure 31: Installation of TS-EC-E-SVAI operating unit

7.7 Mounting 19" Variant TS-EC-E-CR



The external adapter plate (R901384795, not included in delivery) is required for operation of the 19" TS-EC-E-CR variant. This adapter plate is not only used to connect the power supply, but also to connect the protective conductor of the operation unit.

The assembly is divided into 2 sections. In the first section, the control unit is electrically connected to the adapter plate. This is done on the back of both components.

In the second section, it is then installed in the 19"-rack of the WS290 workstation.

Assembly steps – 1. Section:

- ▶ Plug the connector plug of the power cable of the adapter plate into the power socket of the power supply unit of the control unit.
- ▶ Plug the connecting plug of the protective conductor cable of the operating unit into the connecting plug of the adapter plate.

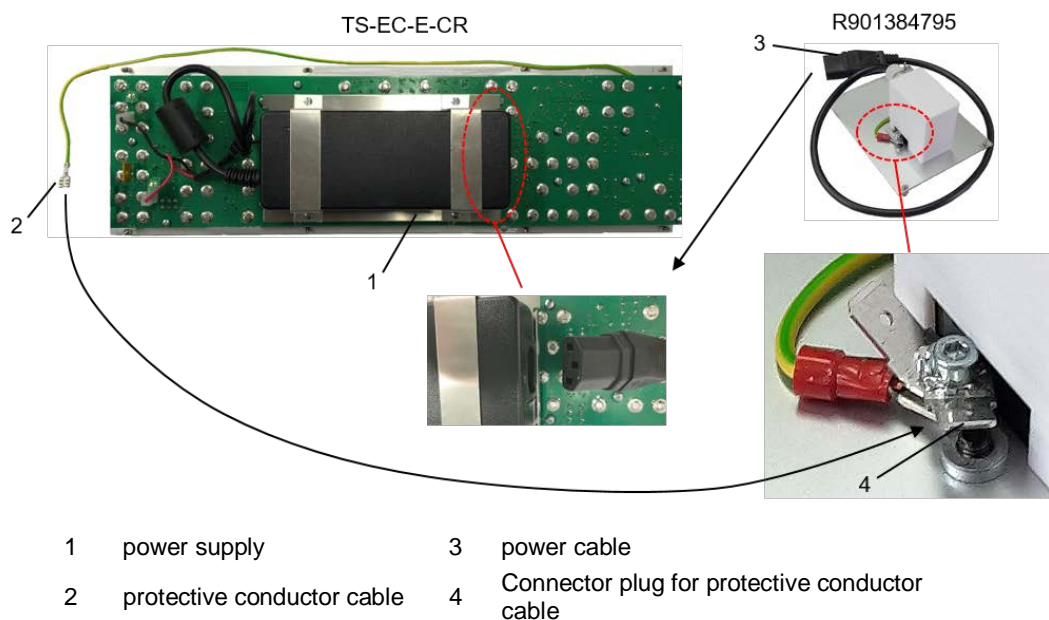

Figure 32: Assembly steps 19" Variant TS-EC-E-CR – 1. Section

Assembly steps – 2. Section:

- ▶ Take both components and place them in the lower right half of the WS290 19"-rack. Hold both components loosely to the intended position. The adapter plate is positioned flush on the right in the lower right half of the 19"-rack and the operation unit is positioned with some distance (at least 1 cm) to the left.
- ▶ Tighten the control unit with at least 2 screws. The adapter plate can hang loosely from the cables.
- ▶ Mount the adapter plate flush on the right in the 19"-rack and tighten it with the 4 screws.
- ▶ Remove the operation unit again.
- ▶ Mount the operation unit flush to the left of the adapter plate. During installation, stow the cables behind the operation unit.
- ▶ Screw the control unit tight with the 8 screws.

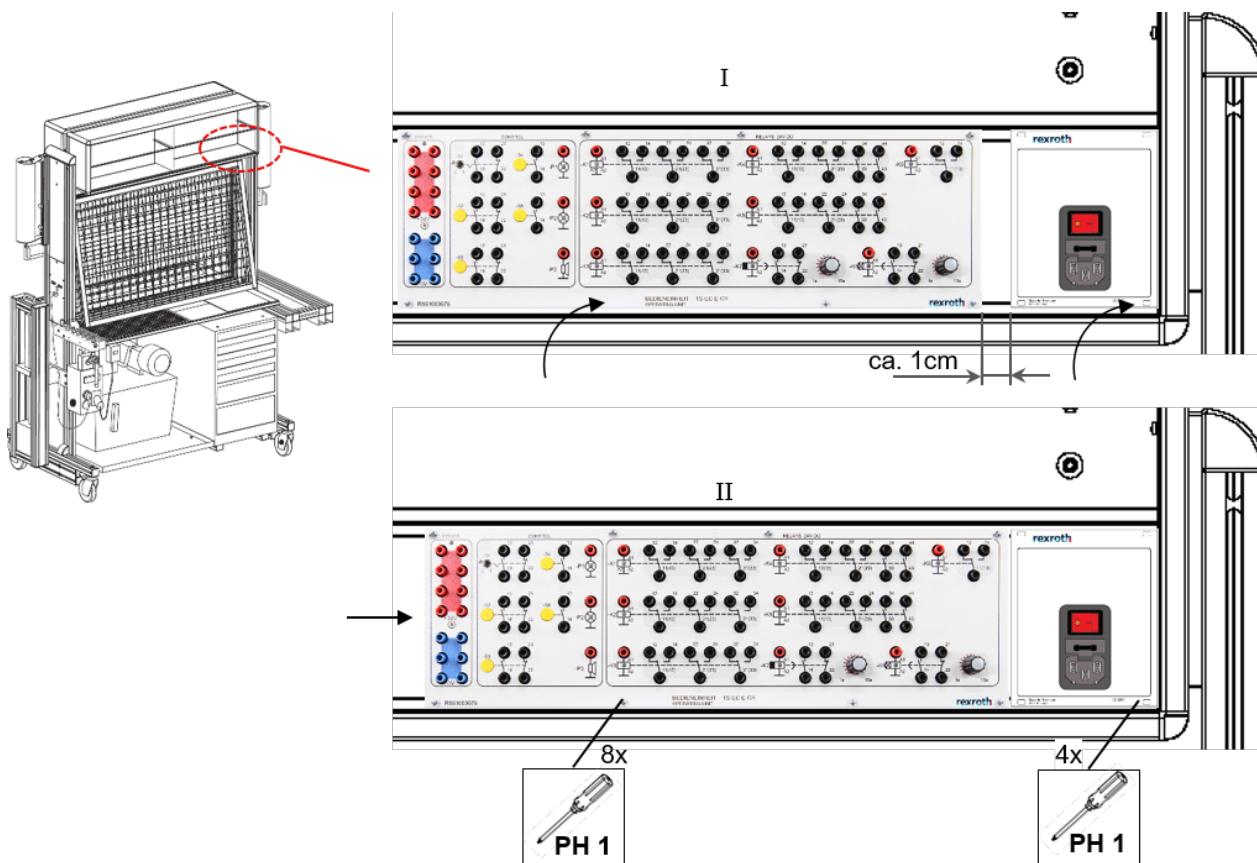

Figure 33: Assembly steps 19" Variant TS-EC-E-CR – 2. Section

7.8 Mounting 19" Variant TS-EC-E-SVAI

There are 2 variants for mounting the TS-EC-E-SVAI control unit. Depending on how you use this operation unit.



Operation of the TS-EC-E-SVAI variant alone is not possible!

A power supply of the operating units via the front side (Power, 0V) is not permitted, as the circuit board protection by the circuit board fuse does not function here.

The differences between the variants are listed below:

- Variant 1
Mounting this operating unit in conjunction with the TS-EC-E-CR operating unit and a WS290
- Variant 2
Mounting this operating unit as an extension of the TS-EC-G-CR operating unit (housing variant) and a WS200 or WS201. Mounting is already described in chapter 7.6.

7.8.1 Mounting in connection with operating unit TS-EC-E-CR & WS290

With this variant, the power supply is via the TS-EC-E-CR operating unit.

The TS-EC-E-SVAI operating unit is already equipped with the required connection cables for this purpose. The connecting cables for the power supply have plug contacts on both sides.

Depending on the application, the user can determine the mounting sequence himself.

Example 1: The WS290 19"-rack is already equipped with the TS-EC-E-CR control unit and the adapter plate.

The user first installs the TS-EC-E-SVAI operation unit in the upper half (flush on the right) of the 19"-rack. Then remove the TS-EC-E-CR operation unit from the lower half of the 19"-rack and connect the supply lines. He can then reinstall the operation unit. Finally, he must remove the adapter plate in order to connect the protective conductor.

Example 2: The module housing of the WS290 is to be equipped with the TS-EC-E-CR operating unit, adapter plate and the operation unit TS-EC-E-SVAI.

Assembly steps:

- ▶ Disconnect both supply lines (black and red) from the circuit board of the TS-EC-E-SVAI operating unit and plug them onto the circuit board of the TS-EC-E-CR operating unit according to the illustration (Fig. 34).
- ▶ Install the TS-EC-E-CR operating unit and the adapter plate according to the instructions in chapter 7.7. The two supply lines (black and red) must hang out upwards in the rack.
- ▶ Plug the connectors of the two supply lines (black and red) into the corresponding slots (as shown) of the circuit board of the TS-EC-E-SVAI operating unit.
- ▶ Mount the TS-EC-E-SVAI operating unit flush on the right in the upper right half of the rack and tighten it with the 8 screws.
- ▶ Remove the adapter plate and connect the protective conductor cable of the TS-EC-E-SVAI operating unit to the free slot.

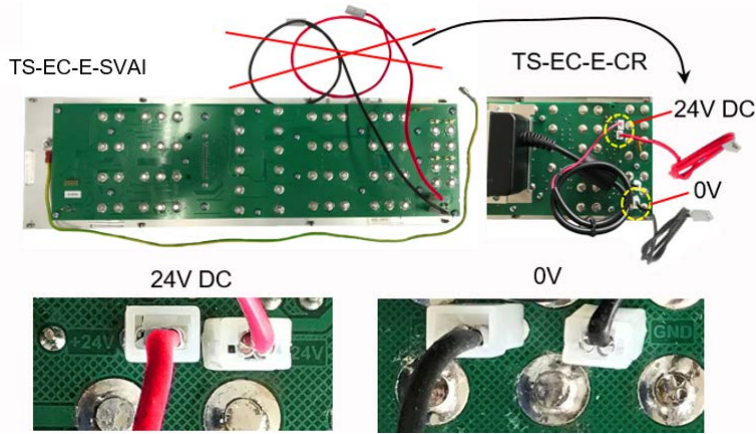

Figure 34: Connection of supply lines to operation unit TS-EC-E-CR

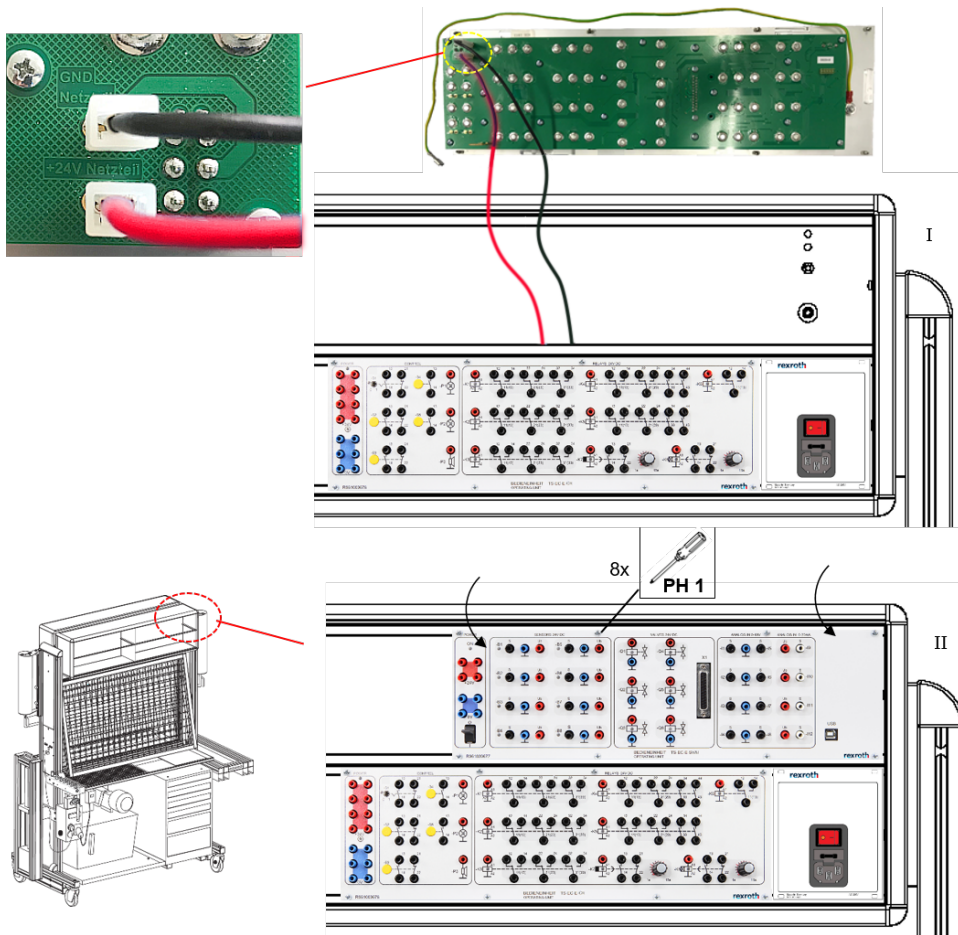

Figure 35: Connection and installation of the TS-EC-E-CR and TS-EC-E-SVAI operation unit

7.8.2 Mounting in connection with operating unit TS-EC-G-CR

The mounting is described in chapter 7.6.

8 Commissioning

WARNING

Danger from working in the danger area of a machine/plant!

Risk of death, injury or serious injury!

- ▶ Pay attention to potential sources of danger and eliminate them before putting the operating units into operation.

CAUTION

Danger due to irregularities, deviations, malfunctions, defects during commissioning!

Risk of injury, damage to components!

- ▶ Do not put the operating units into operation.
- ▶ Determine the cause and remedy the defect. If this is not possible, contact your local Bosch Rexroth service representative.

This chapter describes initial commissioning and recommissioning after standstill.

8.1 Initial Commissioning

Initial commissioning requires faultless installation in accordance with Chapter 7.

The housing variants are ready for operation after connecting a mains voltage.

The 19" variants are ready for operation after connecting a mains voltage to the adapter plate.

8.2 Putting back into operation after a longer standstill

The housing variants are ready for operation after a longer standstill after connecting a mains voltage.

The 19" variants are ready for operation after a longer standstill after connecting a mains voltage to the adapter plate.

9 Operation

WARNING

High electrical voltage!

Danger of death, injury due to electric shock.

Live parts are dangerous.

- ▶ Do not open any covers or sockets during operation.
- ▶ Do not disconnect or connect connectors while they are live.

9.1 Practical exercise

9.1.1 Representation of electrical circuits

Electrical circuit designs are carried out as technical drawings in which the electrical equipment (e.g. relays, lamps, switches ...) and their interaction are represented. These circuit diagrams are compiled from standardised circuit symbols (symbols). The individual components of a circuit are identified in the circuit diagram with standardized letter abbreviations and numbers. The relevant standards are DIN EN 81346-2 for the identification of equipment and DIN EN 60617 for the representation of graphic symbols in circuit diagrams.

Using the example "Switching a lamp by a relay", the different representation of the electrical circuit required for this is shown below.

Circuit diagram in coherent representation

For this type of graphical representation of an electrical circuit, the following applies rules:

- All parts of a piece of equipment (e.g. relays) are represented as a whole (in spatial proximity) and connected with a mechanical active line (dashed line).
- The actual spatial arrangement is not taken into account.
- Main circuit and control circuit are drawn into each other
- The illustration shows the currentless, not actuated state

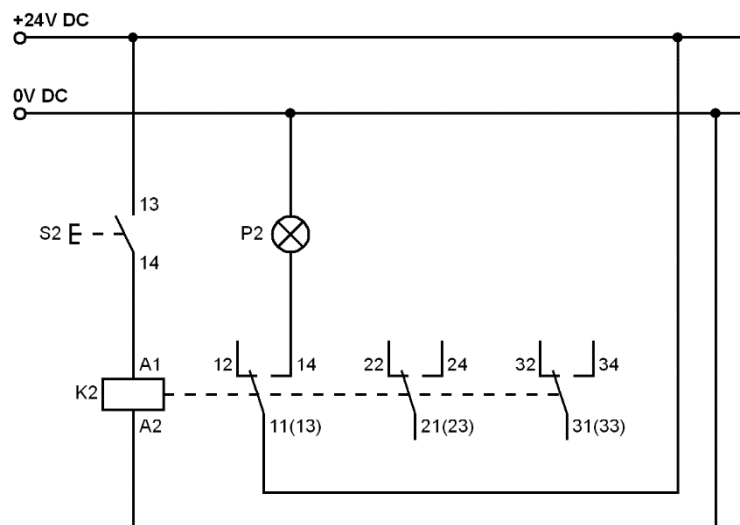

Figure 36: Circuit diagram exercise 1

Implementation of the circuit diagram on the Bosch Rexroth TS-EC-G-CR or TS-EC-E-CR operation unit

The following figure shows the actual wiring of the previous schematic example on the TS-EC-G-CR or TS-EC-E-CR operation unit.



The following components are already internally connected to ground (0V) on the control unit, which reduces the need for external wiring:

- Terminals A2 of the relay coils
- one connection side of lamps P1 and P2
- one connection side of the acoustic detector P3

The internal connection to ground is marked on the operation unit with the standardized graphic symbol (\perp). Therefore, only 4 red safety test leads are required for wiring the circuit. See the illustrations below.

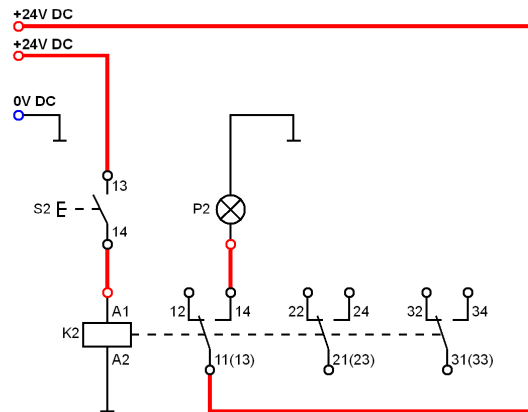

Figure 37: Wiring according to wiring diagram

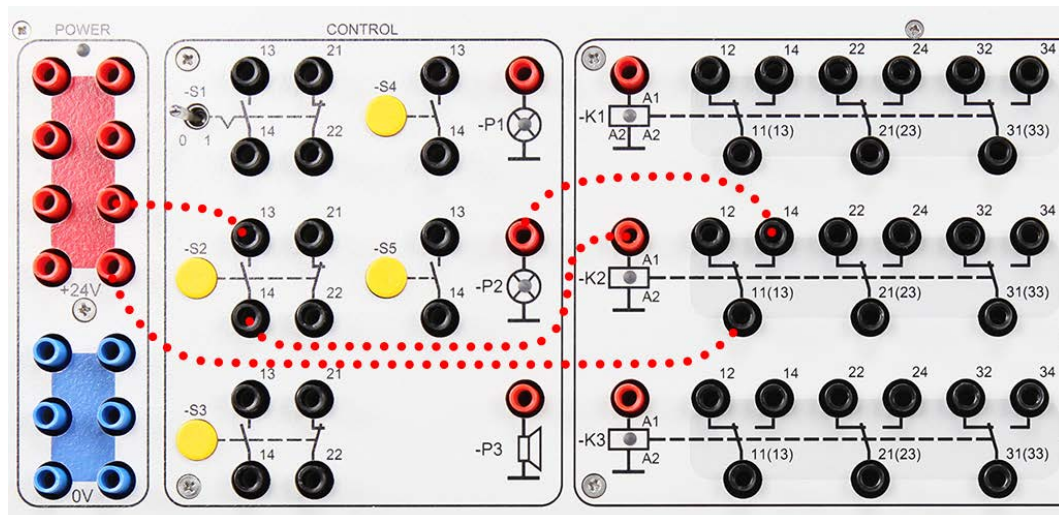

Figure 38: Wiring exercise 1

By pressing the button "S2" the coil of the relay "K2" is activated and the switching contacts close. Via the switching contacts "11(13)" and "14" of the relay "K2" the lamp "P2" is supplied with voltage and lights up. When the button "S2" is released, the activation of coil "K2" is interrupted, the switching contacts are opened and lamp "P2" goes out.

9.2 Operation of the TS-*-*-*SVAI operating units

This chapter describes the operation of the operating units with the simulation software (e.g. Automation Studio).

First, the simulation software and the OPC software must be installed.

To operate the simulation software "Automation Studio" (Famic), the computer to be used (PC or laptop) must meet the following minimum requirements:

- Operating System Professional Edition (32-bit or 64-bit): Windows 7 SP1, 8, 8.1, 10 or Windows Server 2008R2 SP1, 2012, 2012R2 or 2016. It is not recommended to install Automation Studio™ on a server machine.
- Microsoft Office not required, but if present, must be 32 bit for 32-bit installation of Automation Studio™ or 64 bit for 64-bit installation of Automation Studio™. Example You have MS Office 32 bit then you must also install Automation Studio 32 bit.
- CPU: Intel Core 2 Duo 1.83 GHz or equivalent. Recommended: Intel Core i7.
- Automation Studio™ takes advantage of multi-core processors.
- Memory: 2 GB more than the amount required by the operating system. Recommended: 3 GB for the 32-bit version and 8 GB for the 64-bit version.
- Graphic Card: Video memory 512 MB and up, with a screen resolution of 1024 x 768 minimum.
- Disk space: 2.5 GB of free space (without considering the catalogues).
- USB port required, to support the protection key

9.2.1 Installing the Software

The following screenshots were taken with operating system "Windows 10" (Microsoft Office 32 bit version), Automation Studio "6.1 Educational Edition" and software "Lucas-Nülle OPC Server for CO3538-8P".

Different software installations (versions) may lead to different screenshot display.

Automation Studio

Detailed instructions on how to install Automation Studio software can be found on the Internet on the manufacturer's homepage www.famictech.com. There you can navigate to "Support" and "Manual".

The screenshot shows the Famic Technologies Inc. website. At the top left is the Famic Technologies Inc. logo. To the right is a language dropdown menu set to 'English' and a search bar. Below the logo is a navigation menu with 'Company', 'Products', 'Services', 'Events', 'Support', and 'Contact Us'. The 'Support' menu is expanded, showing options like 'Technical Support', 'Guides', 'Product Registration', 'Maintenance Program', 'Maintenance Plan', and 'Subscription Form'. The 'Guides' option is selected, leading to the 'Automation Studio™ Guides' page. The page title is 'Automation Studio™ Guides' and the main heading is 'Automation Studio™ Installation Guide'. Below the heading is a sub-heading 'Automation Studio™ Installation Guide' and a paragraph: 'This guide provides information to help you install your software.' A red box highlights the 'Download the guide' button.

Figure 39: Installation guide Automation Studio

Driver files (OPC Software)

The required files are located on the supplied data carrier. Start the installation with the file "setup.exe".

If you select "User-defined" during the installation, you can define the installation directory. If you select "Typical", the installation directory is automatically set to "C:\Program Files(X86)\LN".

The following illustrations show the individual installation steps.

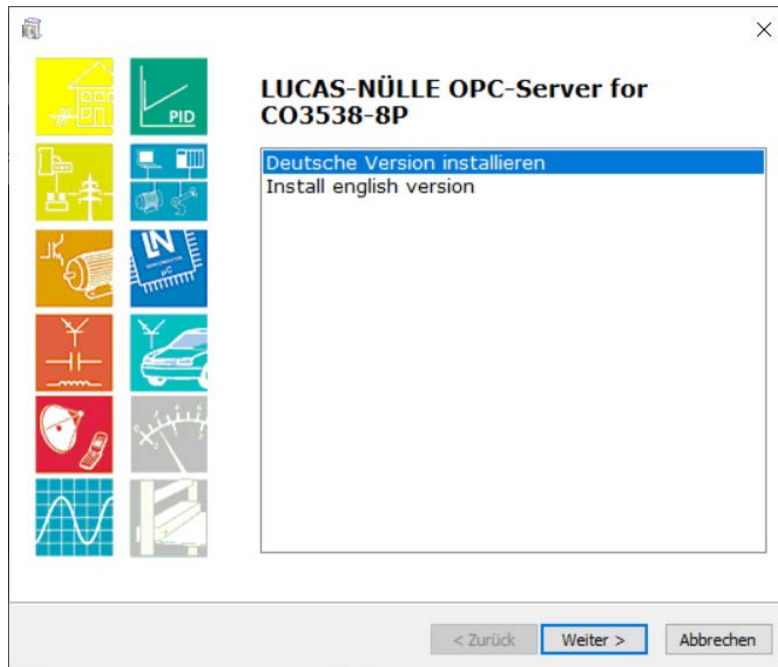

Figure 40: Step 1

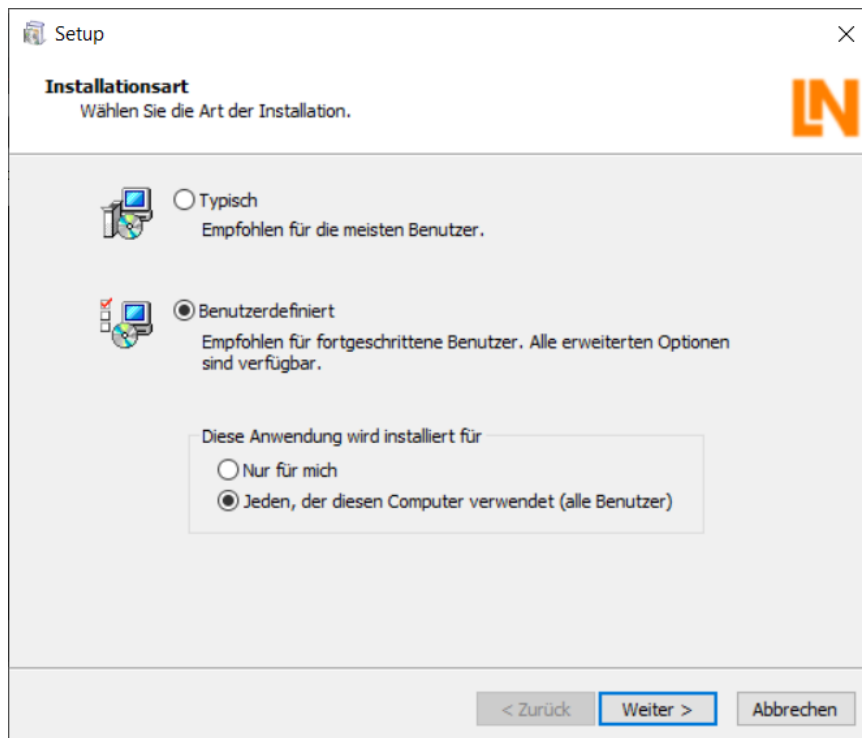

Figure 41: Step 2

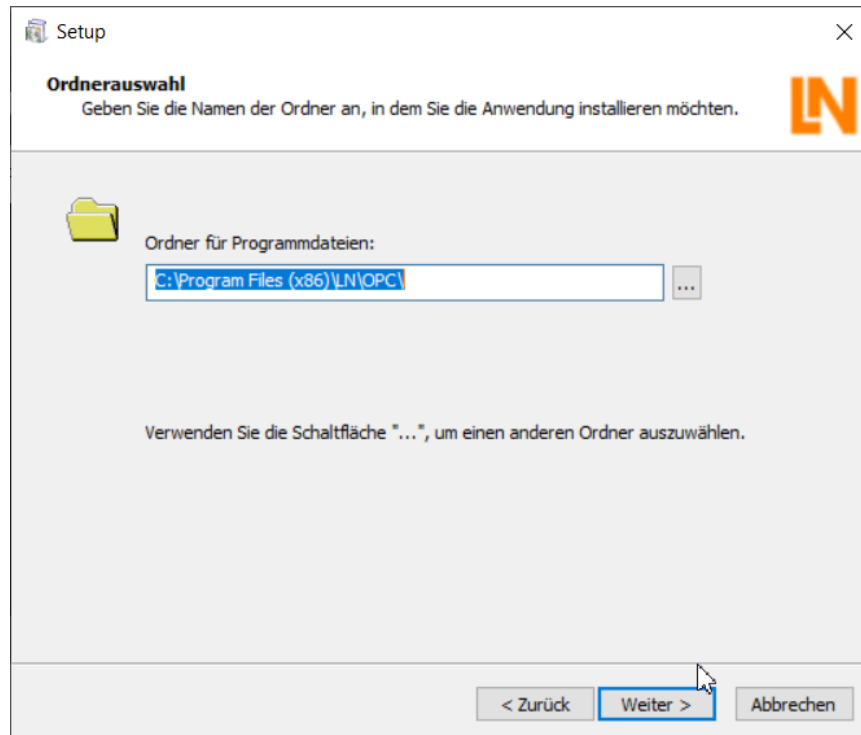

Figure 42: Step 3

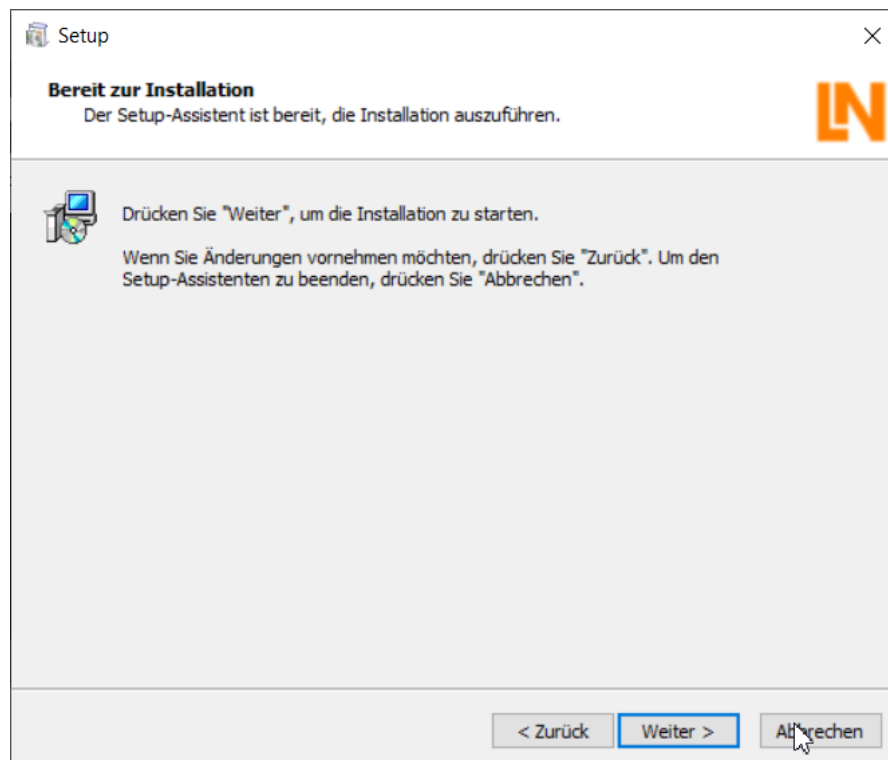

Figure 43: Step 4

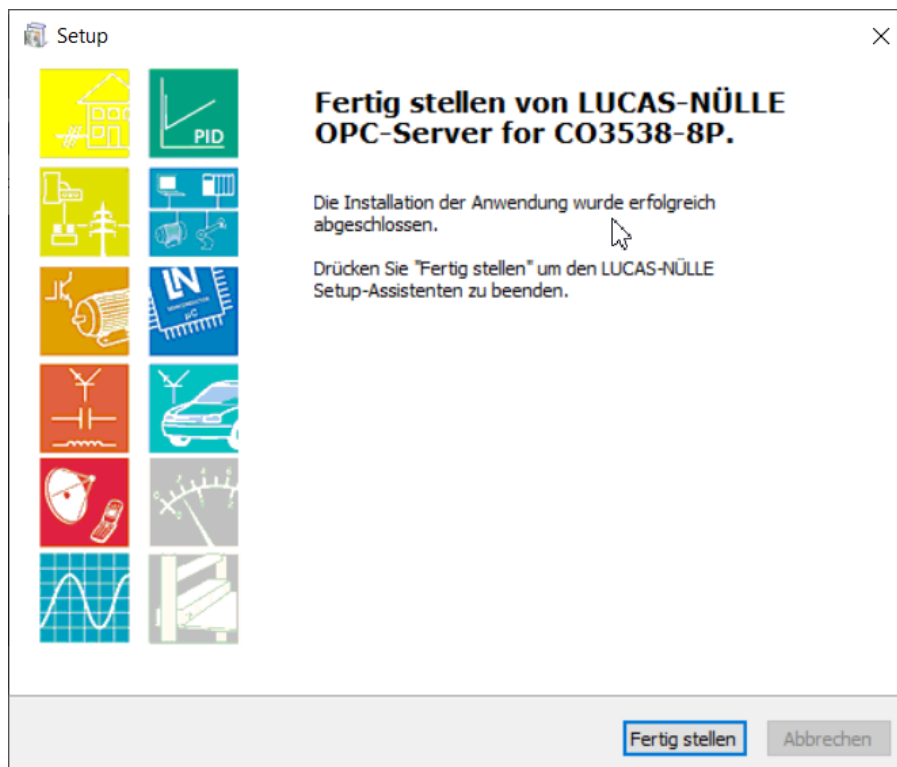

Figure 44: Step 5

9.2.2 Connecting the OPC Software to Automation Studio

To connect the operating unit to Automation Studio, an OPC server must be set up in Automation Studio. The following prerequisites must be fulfilled for this:

- Automation Studio is installed
- Driver files (OPC software) were installed
- Administrative release for the PC exists
- Operating unit is supplied with power and connected to the PC via USB

Start Automation Studio and perform the corresponding steps as shown in the following illustrations.

- ▶ Click on the Variable Manager button.

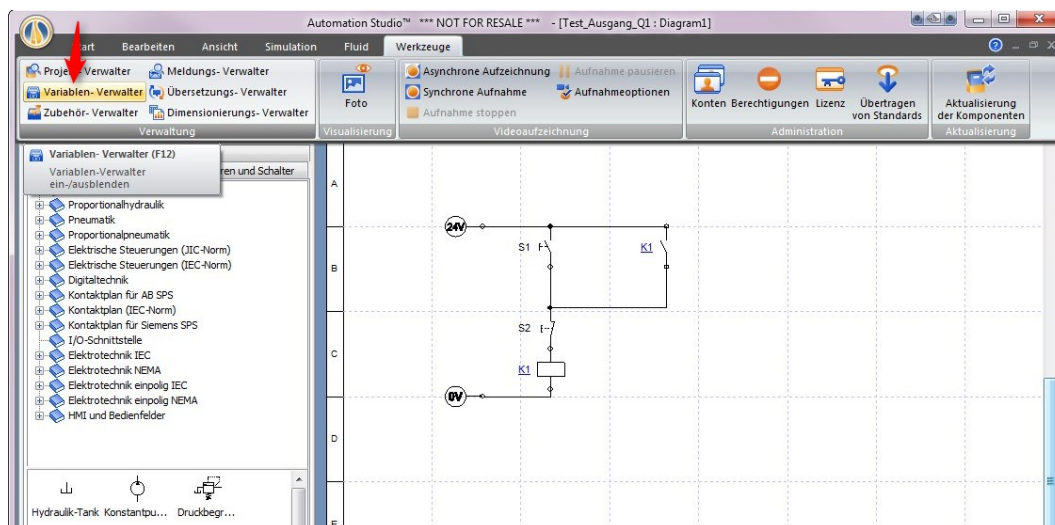

Figure 45: Step 1

- ▶ Open the window OPC Client (1), start the search (2) and select "Lucas-Nülle OPC" in the result window. Confirm the selection (4)

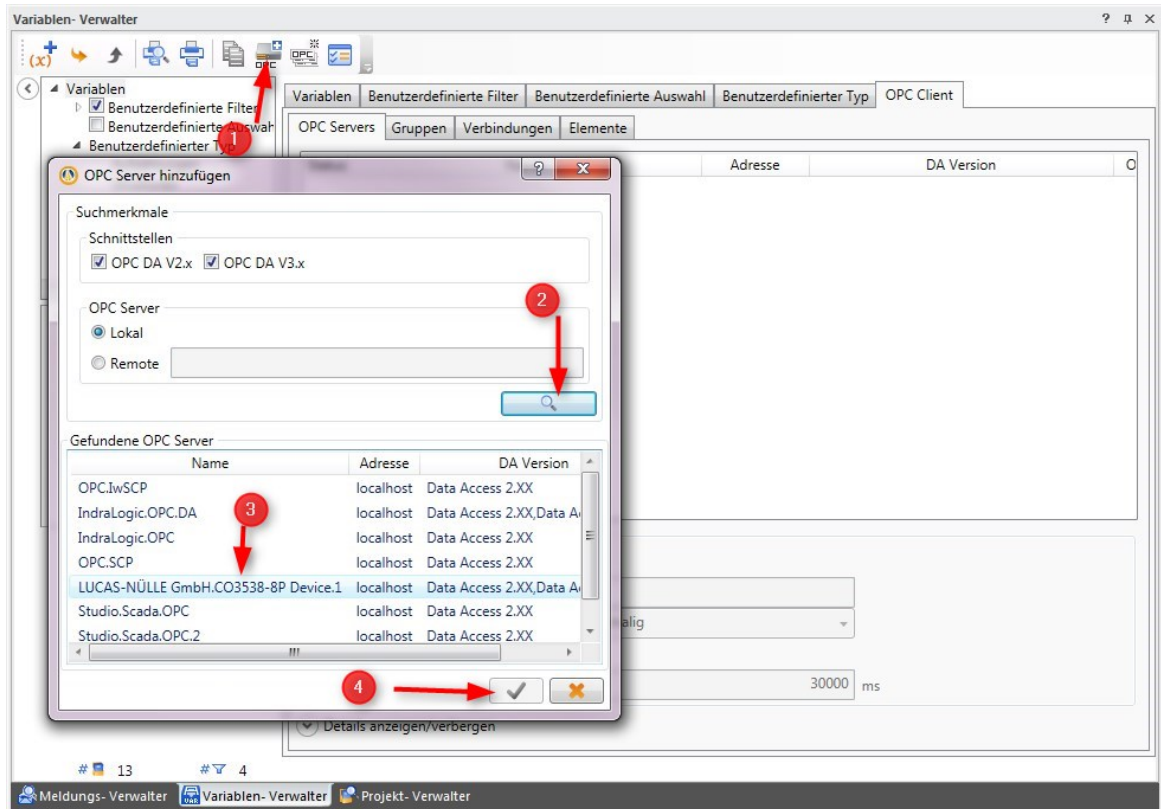

Figure 48: Step 3

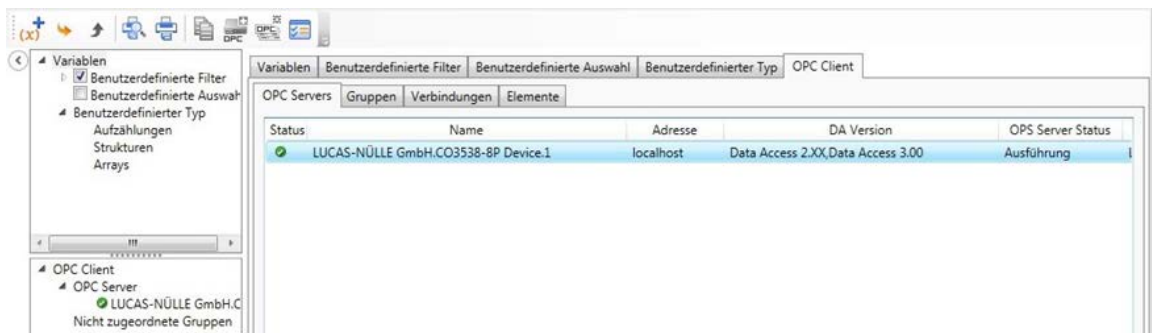

Figure 49: Successfully integrated OPC Server

- ▶ Switch to the "Groups" tab. Click the (1) Insert group button. In the "OPC Server" window, select "Lucas Nülle OPC" (2).

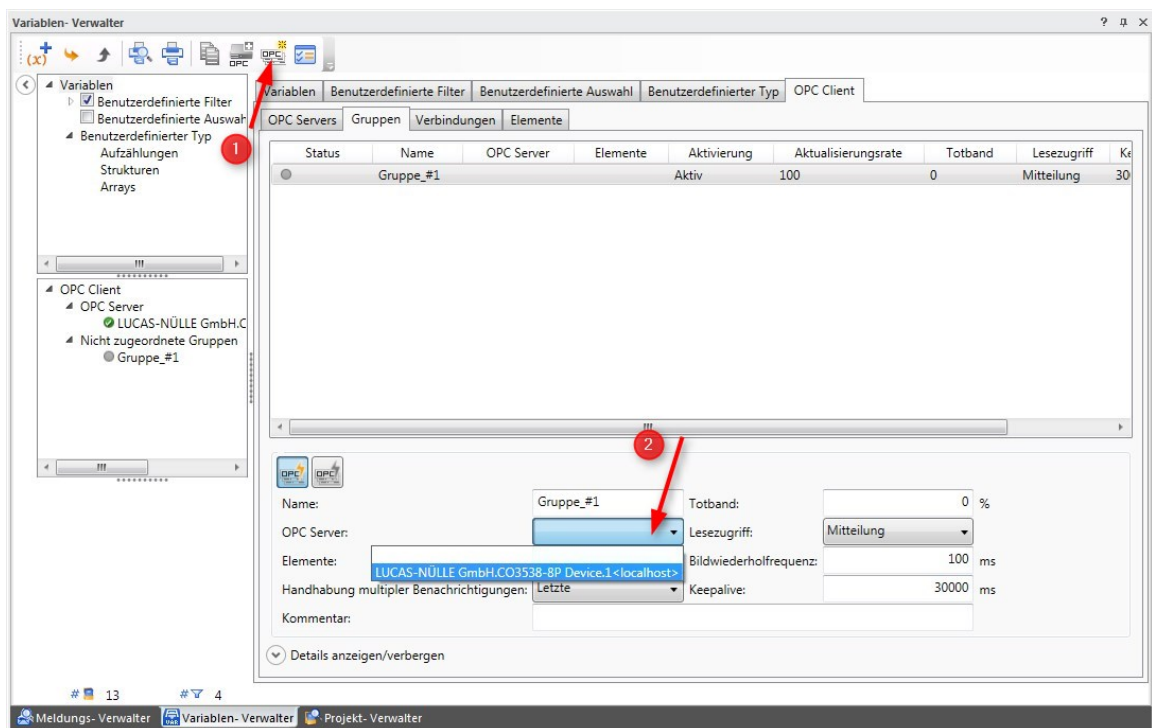

Figure 50: Step 4

- ▶ Switch to the "Connection" tab (1). Select the "Group_#1" (2). In the "OPC Elements" window (3) the control unit is now visible and can be used.

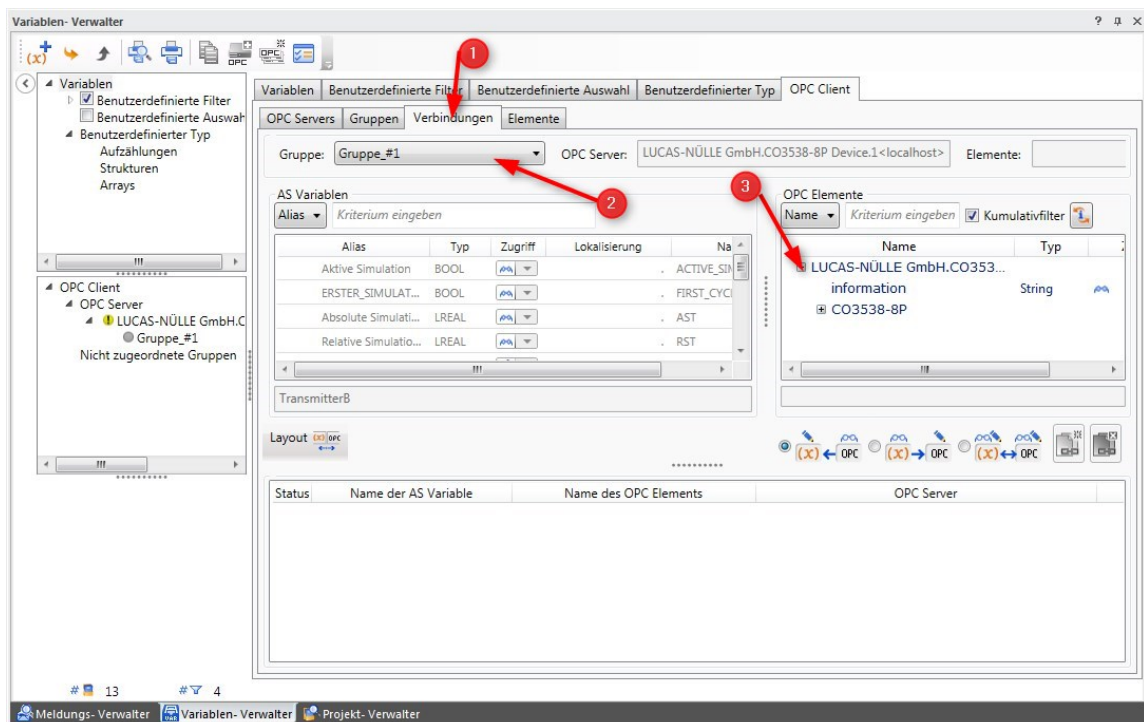

Figure 51: Step 5

10 Maintenance and repair

The operation units are mainly electronic components.
Please contact your Bosch Rexroth Service Partner for a repair.

10.1 Maintenance

The operation units are mainly electronic components.
Maintenance is not necessary.

11 Disassembly Replacement

A faulty control unit must be completely replaced.

Depending on the type of operating unit (housing variant or 19" variant), use the corresponding subchapter of main chapter 7 "Assembly" for removal.

For replacement, contact your Bosch Rexroth Service Partner.

12 Disposal

Careless disposal of the operation units and the packaging material can lead to environmental pollution. The following points must be observed during disposal:

1. Disassemble the operation units in order to recycle them.

To do this, remove the printed circuit boards from the front panels.

2. Separate by materials, for example:

- Steel (fixing screws)
- Aluminium (front panels 19" variants)
- Electrical scrap (printed circuit boards)
- Plastic (housing, front panel of the housing variants)

3. Dispose of the control units and the packaging material in accordance with national regulations of their country.

13 Extension and reconstruction

The housing variant TS-EC-G-CR can be extended with the 19" variant TS-EC-E-SVAI. Detailed information can be found in chapter 5.2.1 "Extension option".

14 Troubleshooting and debugging

In case of hardware faults (e.g. defective circuit board) of the operating units, contact your Bosch Rexroth Service Partner.

For software errors, especially when using Automation Studio, you can also use the "www.famic-tech.com" website. There you navigate to the menu item "Support".

On the left-hand side you will find an online manual and an online forum, where you can explain the problem.



Figure 52: Online Help „Automation Studio“

15 Technical data

15.1 Operating unit TS-EC-G-CR (housing variant)

Designation		Unit	Value
Weight		kg	4,6
Dimension	Width max.	mm	455
	Height max.	mm	296
	Depth max.	mm	148
Ambient temperature		°C	35
Relative humidity for operation		%	5 to 60, non-condensing
Installation site		in weather-protected areas	
Mains connection	Supply voltage	V AC	110-230
	Frequency	Hz	50-60
	Protective earthing	---	PE (zeroing or ground fault circuit interrupter)
Operation voltage	Nominal voltage	V DC	24
	Maximum output current	A DC	4
	Delay time of the time relays	s	1-15
Toggle	Maximum switching current at 24V/DC	A	5
Push button	Maximum switching current at 24V/DC	A	2,5
Signal lamp	Supply voltage	V DC	24
Buzzer	Supply voltage	V DC	24
Relay	Nominal voltage	V DC	24
	Maximum switching current	A	2,5

Table 21: Technical data TS-EC-G-CR (housing variant)

15.2 Operation unit TS-EC-G-CR-SVAI (housing variant)

Designation		Unit	Value
Weight		kg	4,9
Dimension	Width max.	mm	455
	Height max.	mm	296
	Depth max.	mm	148
Ambient temperature		°C	35
Relative humidity for operation		%	5 to 60, non-condensing
Installation site		in weather-protected areas	
Mains connection	Supply voltage	V AC	110-230
	Frequency	Hz	50-60
	Protective earthing	---	PE (zeroing or ground fault circuit interrupter)
Operation voltage	Nominal voltage	V DC	24
	Maximum output current	A DC	4
	Delay time of the time relays	s	1-15
Toggle	Maximum switching current at 24V/DC	A	5
Push button	Maximum switching current at 24V/DC	A	2,5
Signal lamp	Supply voltage	V DC	24
Buzzer	Supply voltage	V DC	24
Relay	Nominal voltage	V DC	24
	Maximum switching current	A	2,5
Digital inputs	Input voltage	V DC	24
Digital outputs	Output voltage	V DC	24
Analog voltage inputs	Input voltage	V DC	0-10
Analog current inputs	Input current	mA	0-20

Table 22: Technical data TS-EC-G-CR-SVAI (housing variant)

15.3 Operation unit TS-EC-E-CR (19" Variant)

Designation		Unit	Value
Weight		kg	1,9
Dimension	Width max.	TE	84
	Height max.	HE	3
	Depth max.	mm	128
Ambient temperature		°C	35
Relative humidity for operation		%	5 to 60, non-condensing
Installation site		in weather-protected areas	
Mains connection	Supply voltage	V AC	110-230
	Frequency	Hz	50-60
	Protective earthing	---	PE (zeroing or ground fault circuit interrupter)
Operation voltage	Nominal voltage	V DC	24
	Maximum output current	A	4
	Delay time of the time relays	s	1-15
Toggle	Maximum switching current at 24V/DC	A	5
Push button	Maximum switching current at 24V/DC	A	2,5
Signal lamp	Supply voltage	V DC	24
Buzzer	Supply voltage	V DC	24
Relay	Nominal voltage	V DC	24
	Maximum switching current	A	2,5

Table 23: Technical data TS-EC-E-CR (19" Variant)

15.4 Operation unit TS-EC-E-SVAI (19" Variant)

Designation		Unit	Value
Weight		kg	1
Dimension	Width max.	TE	84
	Height max.	HE	3
	Depth max.	mm	85
Ambient temperature		°C	35
Relative humidity for operation		%	5 to 60, non-condensing
Installation site		in weather-protected areas	
Mains connection	Supply voltage	V AC	110-230
	Frequency	Hz	50-60
	Protective earthing	---	PE (zeroing or ground fault circuit interrupter)
Operation voltage	Nominal voltage	V DC	24
	Maximum output current	A DC	4
	Delay time of the time relays	s	1-15
Toggle	Maximum switching current at 24V/DC	A	5
Push button	Maximum switching current at 24V/DC	A	2,5
Signal lamp	Supply voltage	V DC	24
Buzzer	Supply voltage	V DC	24
Relay	Nominal voltage	V DC	24
	Maximum switching current	A	2,5
Digital inputs	Input voltage	V DC	24
Digital outputs	Output voltage	V DC	24
Analog voltage inputs	Input voltage	V DC	0-10
Analog current inputs	Input current	mA	0-20

Table 24: Technical data TS-EC-E-SVAI (19" Variant)

16 Appendix

16.1 List of addresses

You will find the addresses of our national companies under:

<http://www.boschrexroth.com>

Contact person for repair and spare parts

Bosch Rexroth AG

Hydraulics

Zum Eisengießer 1

97816 Lohr am Main

Germany

Telefon: +49 (9352) 18-0

Or the responsible sales companies.

Addresses can be found on the Internet:

<http://www.boschrexroth.de>

16.2 Declaration of conformity for TS-EC-G-CR

EU-KONFORMITÄTSERKLÄRUNG

CO3538-8P791

DECLARATION OF CONFORMITY
DECLARATION DE CONFORMITE

Die Lucas-Nülle GmbH bescheinigt die Konformität für das Produkt

The Lucas-Nülle GmbH herewith declares conformity of the product

Lucas-Nülle GmbH déclare la conformité du produit

Produktbezeichnung: Rexroth Bedienmodul TS-EC-G-CR
Product Name: Electrical Operating module

Katalognummer: CO3538-8P791 (R961009678)
Type: CO3538-8P791 (R961009678)
Type: CO3538-8P791 (R961009678)

mit den folgenden Bestimmungen:

with applicable regulations:
avec les directives suivantes:**EMV-Richtlinie 2014/30/EU**EMC Directive 2014/30/EU
Directive EMC 2014/30/EU**Angewendete harmonisierte Normen /** Harmonized standards applied / Normes harmonisées utilisées**Elektromagnetische Verträglichkeit /** Electromagnetic compatibility/Compatibilité électromagnétique

DIN EN 61326-1:2013-07	Tabelle / table / tableau:	1
DIN EN 55011:2009 + A1 :2010	Gruppe / group / groupe:	1
	Klasse / Class / Classe:	B

Niederspannungsrichtlinie 2014/35/EULow-Voltage Equipment Directive 2014/35/EU
Directive des équipements basse tension 2014/35/EU**Angewendete harmonisierte Normen /** Harmonized standards applied / Normes harmonisées utilisées**Sicherheit /** Safety / Sécurité

DIN EN 61010-1: 2011-07		
	Messkategorie / Measuring Category / Catégorie de mesure:	3
	Verschmutzungsgrad / Degree of Pollution / Degré de pollution:	1

RoHS-Richtlinie 2011/65/EURoHS Directive 2011/65/EU
Directive RoHS 2011/65/EU

Kerpen, 27.06.2014

Christoph Müssener
Geschäftsführer

16.3 Declaration of conformity for TS-EC-G-CR-SVAI

EU-KONFORMITÄTSERKLÄRUNG

CO3538-8P790

DECLARATION OF CONFORMITY
DECLARATION DE CONFORMITE

Die Lucas-Nülle GmbH bescheinigt die Konformität für das Produkt

The Lucas-Nülle GmbH herewith declares conformity of the product

Lucas-Nülle GmbH déclare la conformité du produit

Produktbezeichnung: Rexroth Bedieneinheit TS-EC-G-CR-SVAI
Product Name: Electrical Operating module

Katalognummer: CO3538-8P790 (R961009675)
Type: CO3538-8P790 (R961009675)
Type: CO3538-8P790 (R961009675)

mit den folgenden Bestimmungen:

with applicable regulations:
avec les directives suivantes:**EMV-Richtlinie 2014/30/EU**EMC Directive 2014/30/EU
Directive EMC 2014/30/EU**Angewendete harmonisierte Normen / Harmonized standards applied / Normes harmonisées utilisées****Elektromagnetische Verträglichkeit / Electromagnetic compatibility/Compatibilité électromagnétique**

DIN EN 61326-1:2013-07	Tabelle / table / tableau:	1
DIN EN 55011:2009 + A1 :2010	Gruppe / group / groupe:	1
	Klasse / Class / Classe:	B

Niederspannungsrichtlinie 2014/35/EULow-Voltage Equipment Directive 2014/35/EU
Directive des équipements basse tension 2014/35/EU**Angewendete harmonisierte Normen / Harmonized standards applied / Normes harmonisées utilisées****Sicherheit / Safety / Sécurité**

DIN EN 61010-1: 2011-07

Messkategorie / Measuring Category / Catégorie de mesure: 3**Verschmutzungsgrad / Degree of Pollution / Degré de pollution:** 1**RoHS-Richtlinie 2011/65/EU**RoHS Directive 2011/65/EU
Directive RoHS 2011/65/EU

Kerpen, 27.06.2014

Christoph Müssener
Geschäftsführer

17 Index

A		O	
Abbreviations	7	Operation.....	49
About this documentation	5	P	
About this product	19	Personal protective equipment.....	12
Appendix.....	73	Practical exercise.....	49
Assembly	37	Product- and technology-dependent safety instructions	11
C		Product description	19
Commissioning.....	47	Q	
D		Qualification of personnel	10
Declaration of conformity	74	R	
Dimensions	35	Required and supplementary documentatio	5
Disassembly Replacement	61	Required tool	37
Disposal.....	63	S	
E		Safety Devices.....	12
Extension and reconstruction.....	65	Safety instructions.....	9
Extension option.....	23	Scope of delivery	15
G		Symbols	7
General information on property damage and product damage	13	T	
General safety instructions	10	Technical data	69
I		Transport	36
Identification and nameplate	33	Transport & Storage.....	35
Improper use.....	9	Troubleshooting and debugging.....	67
Initial Commissioning.....	47	TS-EC-E-CR operation unit (19	32
Intended use	9	TS-EC-E-SVAI operation unit (19.....	32
M		TS-EC-G-CR operation unit.....	20
Maintenance and repair	59	TS-EC-G-CR-SVAI operation unit.....	24

Bosch Rexroth AG
Drive & Control Academy
Bahnhofplatz 2
D-97070 Würzburg, Germany
Telefon: 09352 18 1920
trainingsystems@boschrexroth.de
www.boschrexroth.com/academy

Subject to change
Printed in English
TS-EC-E-SVAI; TS-EC-G-CR-SVAI;
TS-EC-E-CR; TS-EC-G-CR
Mat-Nr. R901524148