

**MTC200 / MT-CNC
NC Program Restart
18VRS**

Application Manual

DOK-MTC200-SATZVOR*V18-ANW1-EN-P



Title	MTC200/MT-CNC NC Program Restart 18VRS
Type of document	Application Manual
Document code	DOK-MTC200-SATZVOR*V18-ANW1-EN-P
Internal file reference	<ul style="list-style-type: none">Folder 5 / Register 11Drawing number: 109-1041-4116-01
Purpose of the document	This document is used for support during NC program restart commissioning.

Configuration control

Revision	Date	Remarks
109-1041-4116-01	07.98	New issue

Copyright	© INDRAMAT GmbH, 1998 Copying this document and giving it to others and the use or communication of the contents thereof without express authority are forbidden. Offenders are liable for the payment of damages. All rights are reserved in the event of the grant of a patent or the registration if a utility model or design. (DIN 34-1)
Validity	All rights are reserved with respect to the content of this documentation and the availability of the product.
Published by	INDRAMAT GmbH • Bgm.-Dr.-Nebel-Str. 2 • D-97816 Lohr a. Main Phone 09352/40-0 • Tx 689421 • Fax 09352/40-4885 Dept. ESM2 (JA)

Contents

1 Introduction	1-1
2 Operator Input Sequence	2-1
2.1 Requirements.....	2-1
2.2 Selecting NC Program Restart.....	2-1
2.3 Selecting a Target Block.....	2-2
2.4 Selecting the Start Block.....	2-2
2.5 Peculiarities in the Selection of Start and Target Block.....	2-3
2.6 Number of Runs.....	2-4
2.7 Starting the Computing Process.....	2-5
2.8 Establishing the Necessary States.....	2-6
2.9 Multi-Block Retrace to the Contour.....	2-6
3 Machine Parameters	3-1
3.1 Auxiliary Function Output During NC Program Restart.....	3-1
4 Machine Data	4-1
4.1 Machine Data Page 'Block Search and REPOS'.....	4-1
4.2 M(16) and Q Function Buffers.....	4-2
5 NC Syntax	5-1
5.1 Primary Block Programming.....	5-1
5.2 Auxiliary Function Buffer.....	5-1
5.3 ADJUST Subroutine.....	5-2
5.4 Peculiarities.....	5-4
NC-Specific Peculiarities.....	5-4
Tool-Management-Specific Peculiarities.....	5-7
6 Interface Signals	6-1
6.1 NC Program Restart is Active.....	6-1
6.2 Starting NC Program Restart (Computing Process).....	6-1
6.3 Interaction of the Interface Signals.....	6-2
6.4 Behavior of the Interface Signals.....	6-3
Axis Control Signals.....	6-3
Process / Mechanism Control Signals.....	6-4
Axis Status Signals.....	6-4
Process / Mechanism Status Signals.....	6-4
6.5 Standard Functions and Function Blocks.....	6-5

7 Examples	7-1
7.1 Simple Milling Machine	7-1
7.2 Turning Center	7-7

1 Introduction

Task of NC Program Restart NC program restart is used for establishing the states in the controller and at the machine that are required for starting the machining process at any block in the NC program.

2 Operator Input Sequence

2.1 Requirements

- Operator Input**
- The 'ready to start' signal (PxxSREADY=1) of the process is applied.
 - The controller contains the program that shall be executed.
 - The program that shall be executed is selected.
 - Automatic mode has been selected.
 - No program is active (PxxSACTIV=0)

Parameter value assignment The 'reverse program execution required' (Bxx.033) and 'manual axis jogging causes reset' (Bxx.036) process parameters must be set to NO.

Key assignments The 'NC program restart' function is not included in the GUI standard assignments of the F and M keys. The machine manufacturer must commission NC program restart according to the description below.

2.2 Selecting NC Program Restart

Selection To select NC program restart, the operator actuates the associated machine control key.

Screen The user interface then displays the NC program restart screen (see figure below), including the associated machine control bar.

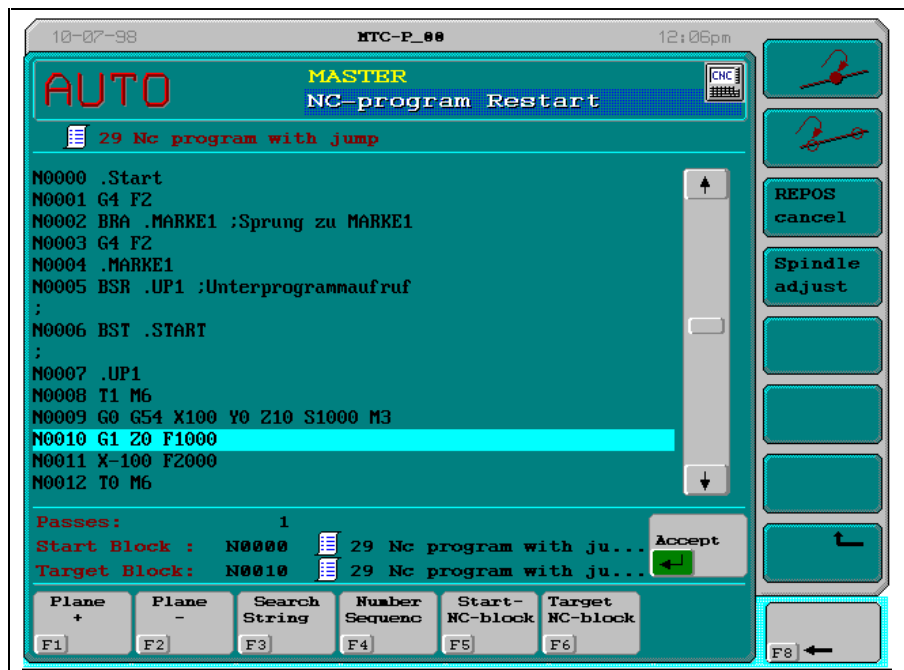

Figure 2-1: NC program restart screen (selecting the target block)

General functionality While the NC program restart is active, the operator can use the <Ctrl> <Page Up> or <Ctrl> <Page Down> key combination to select a different station (provided that more than one station exists and the 'NC program restart' function has been installed there).

2.3 Selecting a Target Block

Target block The target block is the NC block from which the NC continues machining. The NC does not interpret this block during the computing process. The target block can be a primary or a secondary block.

A primary block is a block that contains all the words (NC commands) that are required for starting the machining sequence there. A primary block is identified by the primary block character `:'. All the other blocks are referred to as secondary blocks.

Selection The target block is selected in the same fashion as during block search:

- Use the cursor keys to select the target block, and press the <Enter> key to accept it.
- Use the <POS 1> key to jump to the block N0000. Use the <End> key to jump to the block before the end of the program. Use the page key to scroll an NC program that exceeds the display capacity of one screen page.
- The <Plane+> function locates the jump label that is related to a jump instruction, and sets the cursor to the corresponding NC block.
- Pressing the <Plane-> key enables the operator to return from a subroutine to the calling point.
- Using the <Search String> function, you can locate any character string in the direction towards the end of the displayed NC program (forward direction). The character string may also be a part of a comment.
- Press the <Enter> key to accept the required target block.

2.4 Selecting the Start Block

Start block The start block is the NC block from which onwards the NC shall start the computing process. This can either be the first NC block of the NC program or the last primary block before the target block.

Selection Using the <NC block restart from last primary block> softkey on the user interface to select the last primary block before the target block as the start block.

If you do not select this softkey, the NC always starts the computing process at the beginning of the NC program.

Note: NC program restart from the last primary block should be used for applications, in particular, for which the controller and/or machine states could not be determined during the computing process (e.g. applications with background magazines).

Start block selection is mandatory if there are subroutines at the beginning of an NC program. Otherwise, the NC would start the computing process with the first block of the subroutine.

When the NC program restart screen is exited, the NC sets the 'NC program restart active' interface signal. This signals the SPS that the 'NC program restart' submode is active and that the computing process can be started.

2.5 Peculiarities in the Selection of Start and Target Block

Absolute jumps to the labels
BRA, BST, BEQ, BNE, BPL, BMI,
BRF

If the cursor is placed on an NC block that contains a jump command
 BRA, BST, BEQ, BNE, BPL, BMI, BRF,

pressing <Plane+> causes the label that is specified in the jump command to be located automatically, and the cursor to be set on the related NC block.

Conditional jumps
BES<Label><Event>
BER<Label><Event>

In the conditional jumps BES and BER, the jump to the specified label is always performed in the same way and without evaluating the condition. The cursor can again be positioned within the program. Like in processing, the label is first searched for in the actual program, then in the program 99.

Before the BES or BER jump to the label is performed via the <Plane+> key, you may modify the event via a displayed window (e.g. to influence the synchronization with another process), and jump to the specified label irrespectively of the event's state.

Jumps to other programs
JMP<Progr. No.>
JMP<Variable>

If the cursor is set to a block that contains a JMP command to another program, pressing <Plane+> displays the program that is specified there, and the search for the target and/or start block can be continued there.

With the JMP command, the program number can be transferred using a variable (e.g. JMP @2). When you press the <Plane+> key, the variable value is displayed in a window. At the same time, a new value can be entered for the variable, or a jump can be made to this program, or the action can be aborted.

The search for the target or start block can be continued in the new program.

Subroutine calls
BSR <Label>
JSR<Progr. No.>
BEV<Label><Event>
JEV<Progr. No.><Event>

If the cursor is located on an NC block that contains a subroutine call, pressing the <Plane+> key in conjunction with the commands BSR and BEV causes the specified label to be searched for in the same program or in program no. 99, and the cursor to be set in the located block.

Note: Target and block selection is not possible within a cycle.

With the commands JSR and JEV, the specified program is located and displayed. The cursor sits on the first block N0000 of that program.

Prior to pressing the <Plane+> key for executing BEV or JEV subroutine call, you may modify the event as required. If, in JSR, the program number is transferred via a variable (e.g. JSR @10), a window showing the variable value is displayed prior to the subroutine call. At the same time, a new value can directly be entered for the variable, or the subroutine can be invoked, or the action can be aborted.

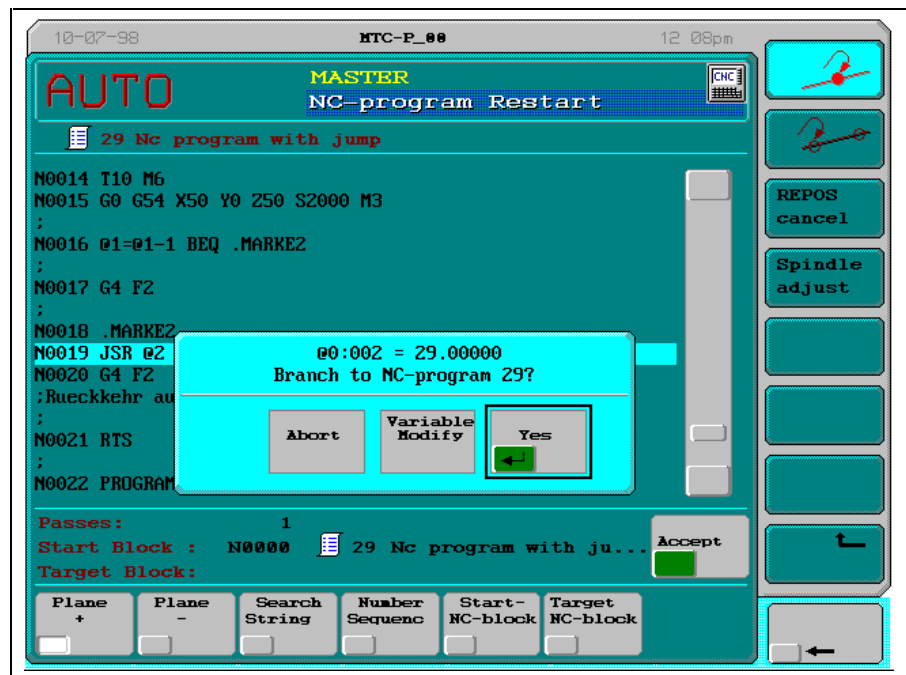

Figure 2-2: Example: Influencing an event with conditional jumps

- Return from the subroutine** If you have pressed the <Plane+> to invoke a subroutine and could not locate the required target or start block in the subroutine, for example, you can press the <Plane-> to return from the subroutine to the calling point in the calling program.
- Number of subroutine calls** From the main program, any target or start block of the related program(s) and subroutines can be selected using the NC program restart screen (provided that the corresponding block is not in a cycle). If necessary, target or start block can be on the 10th level (9 subroutine calls). The command (BSR, JSR, BEV or JEV) that is used for the call is irrelevant.

2.6 Number of Runs

- Number of runs** If the target block is inside a loop or inside several nested loops, you can employ the 'number of runs' function to define the required target block. If you enter a '3' for example, the NC will abort the computing process at the beginning of the target block when it reaches that block for the third time.
- Input** Press the <Number of runs> key if you wish to enter the number of runs. Press the <Enter> key to terminate the input.
- Value range** 1 through 65536
- Default value** Upon each entry, the user interface always stores the value '1' for the number of runs (irrespective of any previous entry).

Note: The 'number of runs' must only be specified if the target block is inside a loop.
After each executed computing process, the NC resets the 'number of runs' register to '1'.

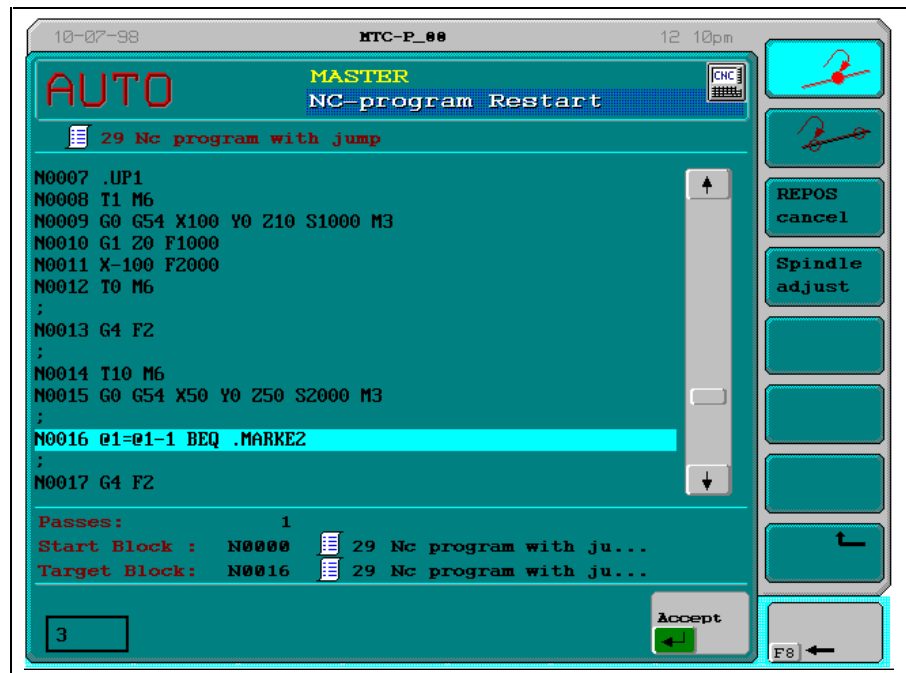

Figure 2-3: Example: Selecting the number of runs

2.7 Starting the Computing Process

Selection	The computing process is usually started automatically when the selection window is closed (see examples). Depending on the configuration, the NC program restart can alternatively be started using a separate M key.
Single-block mode	Selecting single block operation is (like in normal program operation) possible at any time during the computing process.
Computing process	During the computing process, the NC processes the selected NC program like during the normal program mode, taking start and target block into account. However, the controller suppresses the axis movements and the output of the auxiliary functions.
Screen	During computing process, the user interface shows the previously active base screen. Selecting a different station or a different menu is possible at any time.
Target block cannot be found	If the NC encounters an end-of-program command (BST, RET, M02, M30) before it reaches the target block, it issues the error message 'target block cannot be found' and stops program execution.

Note: During the computing process, the stop and the control-reset key have the same functionality as in the normal program mode.
The reverse key is without function during the computing process.

2.8 Establishing the Necessary States

Control states During the computing process, the NC determines the control states that are required for the program entry. This includes the G functions, the auxiliary functions, and the data that is stored in the machine data of the 'NC program restart and REPOS' page.

Machine states The NC executes a subroutine called ADJUST to provide the states at the machine that are necessary for the program entry. In this subroutine, the machine manufacturer chiefly provides for outputting the necessary auxiliary functions and for the necessary tool and workpiece change.

Selection Press the Start key to start the ADJUST subroutine.

Prerequisites The 'multi-block retrace' function must be activated via the SPS before the ADJUST subroutine is started.



CAUTION

Risk of interference

⇒ The machine must be in a state that permits an automatic execution of the ADJUST subroutine. This means, for example, that the axes are in a safe initial position at which tools and workpieces could be changed without any risk if this were necessary.

Recommendation At the end of the ADJUST subroutine, an auxiliary function should be used for selecting manual mode. This enables the operator to move the axes to the contour without any interference (like after a program interruption with subsequent jogging).

2.9 Multi-Block Retrace to the Contour

Multi-block retrace The 'multi-block retrace' function automates the process of positioning the tool back to the contour after a program interruption or after NC program restart (see 'multi-block retrace and return to contour' Description of Functions).

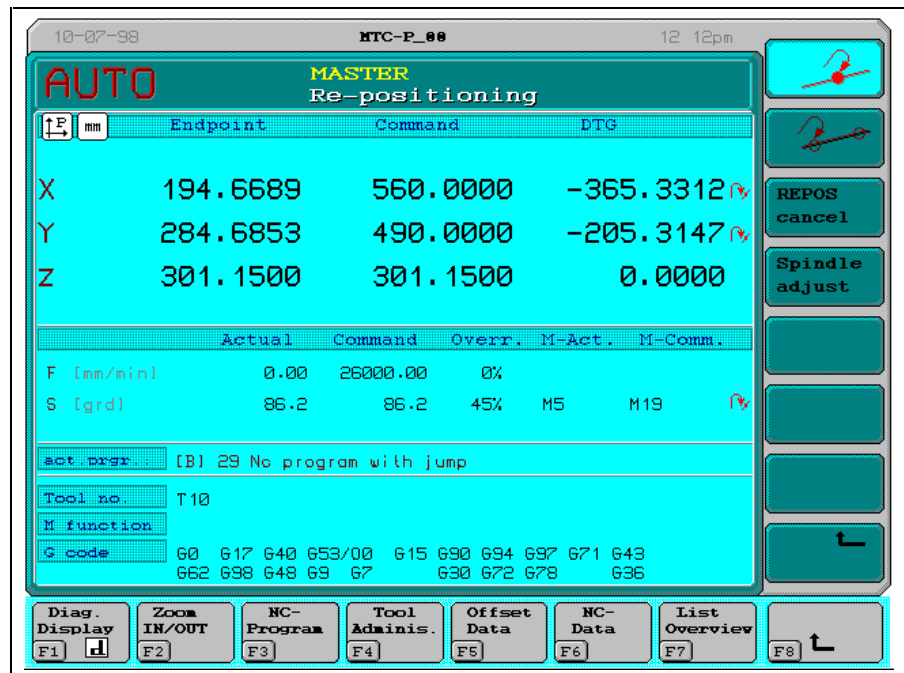

Figure 2-4: 'Re-positioning' screen

Necessary operator input

At the end of the ADJUST subroutine, there is an automatic changeover to manual mode. Like after a program interruption (with subsequent jogging), this enables the user to move the axes to the contour without interference, first in jog mode, and afterwards in automatic mode.

Note: After the ADJUST subroutine has been completed, the NC automatically continues the execution of the REPOS subroutine (provided that manual mode has not been selected before using an auxiliary function).

Selecting manual mode at the end of the ADJUST subroutine enables the operator to move the axes to the contour without any interference (like after a program interruption with subsequent jogging). This is particularly necessary during inside machining and for back cutting.

In this process, the user can jog the axes in manual mode in the vicinity of the re-entry point, then select automatic mode as usual, and continue automatic multi-block retrace and the further program execution without any further interruption.

3 Machine Parameters

3.1 Auxiliary Function Output During NC Program Restart

Designation	<ul style="list-style-type: none"> • M function output during NC program restart • Q function output during NC program restart • S function output during NC program restart • T/E function output during NC program restart
Number	Bxx.058 - Bxx.061
Value range	Yes / No
Default value	No
Unit	-
From version onwards	18V00
Dependency	-
Purpose	The process parameter 'M, Q, S and T/E function output during NC program restart' define the output behavior of the auxiliary function concerned during mid-program startup.
Explanation	<p>If the machine manufacturer sets 'output behavior upon NC program restart' to 'No', the NC will not issue the auxiliary function concerned to the SPS.</p> <p>If, in contrast, the parameter is set to 'Yes', the NC transfers the auxiliary functions concerned according to the selected output and acknowledgment behavior to the SPS, as it does during the normal operation. During mid-program startup, the machine manufacturer can collect the auxiliary functions in the SPS, interpret them and output them upon the next program start.</p> <p>Irrespective of the selected output behavior, the auxiliary functions that establish the states at the machine that are necessary for the entry into the NC program, must be output at the end of the execution. This is done using the '.ADJUST' subroutine.</p>
Peculiarities	<p><u>1. M function groups M(1) through M(15)</u></p> <p>Irrespective of the 'output behavior upon NC program restart', the NC collects the auxiliary functions for each auxiliary function group during mid-program startup (like during normal program operation), and saves the auxiliary function last output of each of the groups (M(1) through M(15)).</p> <p>With the exception of the spindle and gear groups, the groups have the default value -1 assigned (after the controller has been switched on and at the end of the program (BST, RET, M(30)). Use M05, M105, M205 or M305 to assign the default values to the spindle groups.</p>

Note: In manual mode, the auxiliary spindle functions are updated when the spindles are jogged. The controller does not update any other auxiliary function (such as 'coolant ON/OFF') that are output during manual mode.

2. M function group M(16) and Q functions

For the M function group 16 and for the Q function group, the NC saves the last 40 auxiliary functions in the machine data of the 'M(16) and Q function buffer' page. This machine data has '0' preassigned.

Within the M(16) group, the 'M(16)' address can be used for reading the auxiliary function last output. The same is true for the Q functions. The M(16) and Q function groups have the default value -1 assigned (after the controller has been switched on and at the end of the program (BST, RET, M(30))).

Note: The NC does not output the program control commands M00, M01, M02 and M30 to the SPS like all the other M functions if the machine manufacturer sets the 'M function output during NC program restart' parameter to 'No'.

4 Machine Data

4.1 Machine Data Page 'Block Search and REPOS'

Designation NC program restart and REPOS

Page No. 60

From version onwards 18V00

Purpose The 'NC program restart and REPOS' page defines the spindle mode.

Explanation For each process, the 'NC program restart and REPOS' page is of the following structure:

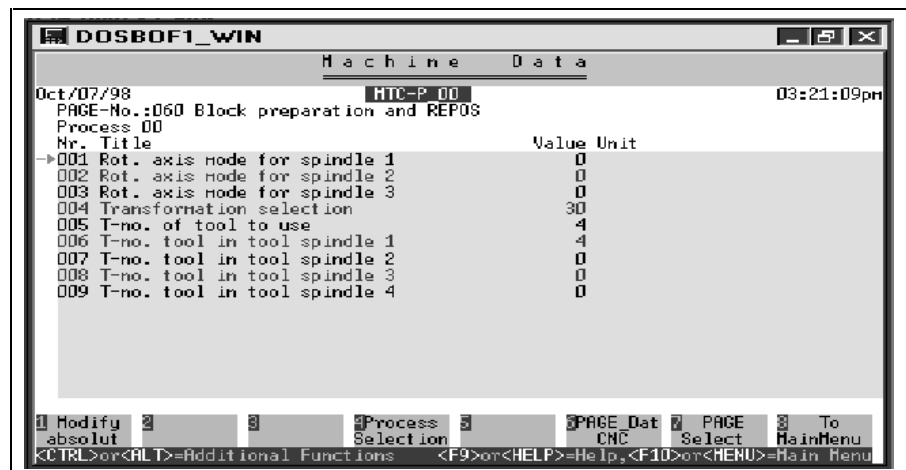

Figure 4-5: Data elements per process of the 'NC program restart and REPOS' page

The following table shows the value ranges, default values, and updating time of the data in the 'NC program restart and REPOS' page.

Data element	Value range	Default value	Updating time
Rotary axis mode for spindle 1 / 2 / 3	0: Spindle mode must be established for the 1st/2nd/3rd spindle of the process. 1: Rotary axis mode must be established for the 1st/2nd/3rd spindle of the process.	0	upon program stop and at the end of the block search when the target block is reached.
Transformation selection	30: Transformation need not be selected 31: G31 must be selected 32: G32 must be selected	30	at the end of the block search when the target block is reached.
T no. of the tool in tool spindle 1 / 2 / 3 / 4	0 through 9999999	0	at the end of the block search when the target block is reached.

Note: The states of the physically existing spindles that are defined in the 'rotary axis mode for spindle 1 / 2 / 3' data elements of the 'NC program restart and REPOS' page must be established within the '.REPOS' subroutine.

The transformation for facing (G31) or lateral cylinder surface machining (G32) must be selected according to the 'transformation selection' machine data element on the 'NC program restart and REPOS' page within the '.ADJUST' subroutine.

If the individual processes contain at least one tool spindle, this tool spindle (and any additional tool spindles) must, within the '.ADJUST' subroutine, be equipped with the tools that are specified in the 'T no. of the tool spindles 1 / 2 / 3 / 4' data elements of the 'NC program restart and REPOS' page.

4.2 M(16) and Q Function Buffers

Designation	M(16) and Q function buffers
Page no.	61
From version onwards	18V00
Purpose	The last 40 M functions that were output within the M function group 16 during the NC program restart, and the last 40 Q functions that were output during the NC program restart can be read at the end of the computing process, and be output to the SPS.
Explanation	The 'M(16) and Q function buffer' page is of the following structure:

Nr.	Title	Value	Unit
001	Aux. Function 1	0	
002	Aux. Function 2	0	
003	Aux. Function 3	0	
004	Aux. Function 4	0	
005	Aux. Function 5	0	
006	Aux. Function 6	0	
→007	Aux. Function 7	0	
008	Aux. Function 8	0	
009	Aux. Function 9	0	
010	Aux. Function 10	0	
011	Aux. Function 11	0	
012	Aux. Function 12	0	
013	Aux. Function 13	0	
014	Aux. Function 14	0	
015	Aux. Function 15	0	

Figure 4-6: Data elements per process and M/Q function group of the 'M(16) and Q function buffer' page

During NC program restart, the NC stores the last 40 M function numbers that were output within the M function group 16. Likewise, it stores the last 40 Q function numbers that were output during NC program restart.

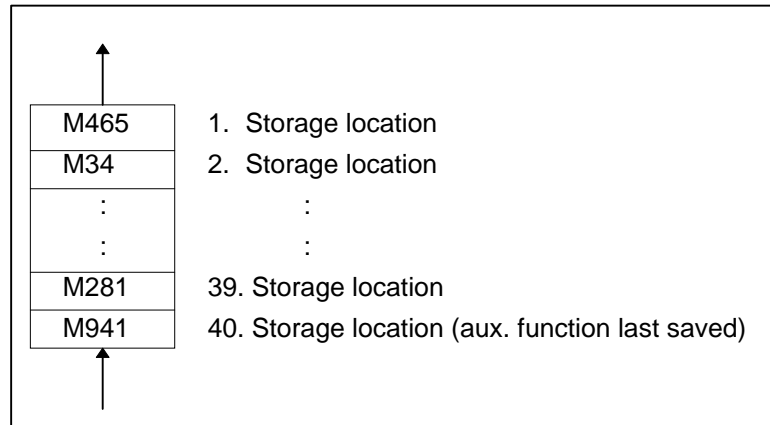

Figure 4-7: Method of operation of the auxiliary function buffer

Note: The NC deletes the auxiliary function that was stored first, and stores the subsequent auxiliary functions in the next lower memory location within the 'M(16) and Q function buffer' machine data page as soon as the auxiliary function buffer overflows (i.e. the 41st M function of group 16 or the 41st Q function must be stored during the computing process). Thus, the new auxiliary function is stored as the 40th auxiliary function.

M19 commands (M19, M119, M219 or M319) are not stored within the 'M(16) and Q function buffer' page.

Default value At the beginning of the NC program restart, the NC initializes all data elements of the 'M(16) and Q function buffer' page that belong to the process with the value '0'.

5 NC Syntax

5.1 Primary Block Programming

Primary block 66257 To DIN 66257, a primary block is a block that contains all the words (NC commands) that are required for (re)starting the machining sequence. A primary block starts with the primary block character.

Primary block character DIN 66025 (part 1) defines a colon ':' as the primary block character. Within an NC block, the colon must be programmed as the first character.

Note: If a primary block shall also be a skipped block, the skip slash '/' must be programmed before the colon.
A primary block can also be programmed in a subroutine.
When primary blocks are programmed, it must be ensured that the start block lies before an incremental dimension (G91) and before an incremental zero offset (G51).

Application A primary block can be used

- as a target block in block search (without computation) or
- as a start block in NC program restart (with computation).

Usually, primary blocks are used for NC program restart (in particular if tools or workpieces are supplied during the program execution from a different process or from the outside).

Example In order to ensure that the operator has a swift program entry during block search and/or NC program restart, primary blocks were programmed in the following programming example.

```

:
; stair II turning
N0825 : T12 M6
N0826 G92 S2800
N0827 G0 G6 G8 G54 G97 X50 Z20 S1500 M3
N0828 G1 X48 F2000
:

```

5.2 Auxiliary Function Buffer

Auxiliary function buffer The auxiliary functions last output during NC program restart within the individual M, Q, S, T or E function groups can be read at the end of the computing process, and be output to the SPS.

Note: At the end of program and upon Control-Reset, the NC initializes all memory locations of the M and Q function groups with the value '-1'. The spindle and gearstep groups are the sole exception.

Besides the M, Q, S, T and E function group, the NC stores the last 40 M functions of the M function group 16 and the last 40 Q functions during the NC program restart within the 'M(16) and Q function buffer' page.

Note: M19 commands (M19, M119, M219 or M319) are not stored within the 'M(16) and Q function buffer' page.

5.3 ADJUST Subroutine

The ADJUST subroutine enables the machine manufacturer to establish the states that are necessary for the program entry at the machine. In this subroutine, the machine manufacturer chiefly provides for outputting the necessary auxiliary functions and for the necessary tool and workpiece change.

The '.ADJUST' jump label must be set at the beginning of the subroutine. Furthermore, the ADJUST subroutine must be written before the REPOS subroutine (without RTS !). This enables the NC to automatically continue with the execution of the REPOS subroutine once it has completed the execution of the ADJUST subroutine.

If a reverse occurs while the ADJUST subroutine is being executed, the NC jumps to the related label and continues execution there before it jumps to the '.HOME' label.

The user can store the ADJUST subroutine in the current NC program, in the program 99, or in the cycle memory.

Example Within the ADJUST subroutine, the necessary states (that are specified through auxiliary functions) at the machine are set for a subsequent multi-block retrace.

```

-----
; Subroutine: ADJUST
-----
;
; Setting the M functions of the M(5) through M(15) group
; Group 5
.ADJUST @100=M(5)-1 BMI .INI_G5 ;Initialization value ?
M=M(5) BRA .ADJ_G6 ;Updating M function group 5
.INI_G5 M109 ;Coolant OFF
; Group 6
.ADJ_G6 @100=M(6)-1 BMI .INI_G6 ;Initialization value ?
M=M(6) BRA .ADJ_G7 ;Updating M function group 6
.INI_G6 M209 ;Coolant OFF
:
:
; Group 15
.ADJG15 @100=M(15)-1 BMI .INIG15 ;Initialization value ?
M=M(15) BRA .ADJUS1 ;Updating M function group 15
.INIG15 M918 ;Chip conveyor OFF
;
; Updating M functions of the group 16
.ADJUS1 @100=1 ;Run index
.ADJ_12 @101=MTD(61, 0, 1, @100)-0 ;Page:61, process:0, auxiliary function:1(M functions)
BEQ .ADJUS2 ;Value=0 ?
@101=MTD(61, 0, 1, @100)-500 BEQ .ADJ_13 ;Value=500 ?
@101=MTD(61, 0, 1, @100)-501 BEQ .ADJ_13 ;Value=501 ?
M=@101 ;Auxiliary function output
.ADJ_13 @100=@100+1 ;Increasing run index
@102=40-@100 BPL .ADJ_12 ;Value>=40 ?
;
; Updating Q functions
.ADJUS2 @100=1 ;Run index
.ADJ_22 @101=MTD(61, 0, 2, @100)-0 ;Page:61, process:0, auxiliary function:2(Q functions)
BEQ .ADJUS3 ;Value=0 ?
@101=MTD(61, 0, 2, @100)-5600 BEQ .ADJ_23 ;Value=5600?
@101=MTD(61, 0, 2, @100)-5700 BEQ .ADJ_23 ;Value=5700?
M=@101 ;Auxiliary function output
.ADJ_23 @100=@100+1 ;Increasing run index
@102=40-@100 BPL .ADJ_22 ;Value>=40 ?
;
; Tool change
.ADJUS3
T=T BSR .M6 ;Changing in tool last selected
;
-----
; Subroutine: REPOS
-----
:
:

```

Process control commands and process synchronization commands

during NC program restart, the NC executes the process control commands (DP, SP, RP, AP, WP, LP and POK) and the process synchronization commands (WES and WER) like in normal operation. A prerequisite is, however, that the individual programs have been started in the individual processes like in normal operation.

Recommendation

If the other processes shall not be taken into consideration (i.e. they shall not be influenced) during the NC program restart, because they already have reached the required program locations in normal operation or via NC program restart, this can be achieved using a skip slash or a conditional jump instruction before the process control commands or process synchronization commands.

Data exchange with digital drives that are equipped with SERCOS interfaces

During the computing process with digital drives (with SERCOS interface), data exchange using the AXD command is performed like in normal program operation. This is also true for APR-SERCOS parameters that are processed by the APR.

Note: An auxiliary function, which the NC does not output during NC program restart and/or the SPS does not process during NC program restart, must be used via the SPS for activating AXD commands that cause a movement.

Example:

Certain functions (such as AXD commands) should not be output to the controller during NC program restart.

There are different implementation possibilities for this purpose:

1. Conditional jumps

Using an event the SPS sets during the NC program restart permits specific functions to be skipped that shall not be executed in the NC during NC program restart:

```

:
BES .BP1 1:15
AXD (X:S-0-0104)=7000 ;new KV factor for X axis
AXD (Y:S-0-0104)=7000 ;new KV factor for Y axis
AXD (Z:S-0-0104)=7000 ;new KV factor for Z axis
.BP1
:

```

2. Implementation in the SPS

In this solution, the SPS executes the functions that must not be processed during NC program restart (such as the AXD commands). As long as these functions are activated using an auxiliary function type (e.g. using Q functions), their output to the SPS during NC program restart can easily be implemented. It merely requires the related process parameter

Bxx.057 Q function output during mid-program startup Yes/No

to be set to No. The associated NC program could then look like this:

```
:  
Q101 ;new KV factor for X axis  
Q102 ;new KV factor for Y axis  
Q103 ;new KV factor for Z axis  
:
```

Axis transfer

The NC processes the axis transfer commands (GAX and FAX) like in normal program operation. If the NC encounters an FAX command during the computing process, it waits until the axis is requested by another process (that may also be in the NC program restart) using GAX. Accordingly, the NC waits upon an axis request using GAX until another process (that may also be in the NC program restart) relinquishes the axis concerned using FAX.

Reading the position value

The NC does not interpret the PMP and NMP commands (that are used for acquiring the current actual position of analog drives) during the computing process.

Tool-Management-Specific Peculiarities

Tool-specific inquiries The NC processes the conditional jump instructions 'BSE' (jump if tool spindle is empty) and 'BTE' (jump if T0 has been programmed) like during normal program operation. During NC program restart, however, it refers to the (virtual) tool spindles that are mapped within the machine data rather than to the real tool spindles.

In contrast, the NC does not take the commands for checking spindle 1 'TSE' and a tool magazine location in position 1 'TPE' into account during the computing process.

Current tools list Besides the correction data of a process, the current tools list contains all data items that are required for the management of all tools that belong to the process. During NC program restart, the tool management does not change the data of the current tools list.

Automatic equipment check The NC performs the automatic equipment check in the same way as it does during the normal program operation when the process-related interface signal 'PxxCMGNTC' is not set.

Mechanisms for providing tools The following table shows the different mechanisms that are used for loading, changing in and activating a tool as a function of the tool storage unit.

Mechanism	Type	Turret	Magazine
Load and activate tool	synchronous and process-internal	Txxx MTP([POS], [DIR]) Txxx MMP([POS], [DIR]) (Parameter 'asynchronous turret movement' = NO)	
	asynchronous and process-internal	Txxx MTP([POS], [DIR]) Txxx MMP([POS], [DIR]) (Parameter 'asynchronous turret movement' = YES)	
Load tool	asynchronous and process-internal	-	Txxx MTP([POS], [DIR]) Txxx MMP([POS], [DIR])
Changing tool into tool spindle and activating it	synchronous and process-internal	-	TCH([POS], [SPI]) TMS([POS], [SPI])
Changing tool into tool gripper	synchronous and process-internal	-	-

Abbreviations:

[]:	optional parameter
DIR:	direction
POS:	position 1, 2, 3 or 4 to be approached
SPI:	tool spindle 1, 2, 3 or 4

Note: Process-overlapping tool changing processes (that are not contained in the table above) are not supported during NC program restart. This means for these applications that the tool that is required for machining must be changed into the corresponding spindle and the NC program restart must be started from the last primary block so that a process-overlapping tool change is not necessary during NC program restart.

Tool storage unit motion commands for loading and activating a tool within a process

The tool storage motion commands MFP, MHP, MMP, MOP, MRF and MTP are used for triggering the necessary movement of the tool storage unit. The MRY command is used for interrogating whether the movement of the tool storage unit is finished.

If the tool storage unit is a turret (process parameter 'type of tool storage' = turret), the MTP and MMP commands are used either

- for synchronous loading and activation of the tools (process parameter 'asynchronous turret movement' = NO) or
- for asynchronous loading and activation of the tools (process parameter 'asynchronous turret movement' = YES)

With a magazine (process parameter 'type of tool storage' = magazine), in contrast, the tool storage motion commands MTP and MMP are used exclusively for asynchronous and process-internal tool loading (motion control of the magazine).

To avoid illegal movements, the NC does not perform the MFP, MHP, MMP, MOP, MRF and MTP motion commands and the MRY interrogation. With SPS-controlled tool storage units, this means that during the computing process the NC does not send the SPS the position that shall be moved to and does not activate the MMV and MRF standard functions.

Loading tools from a different process

During NC program restart and within a process, the NC can only access the tool data that is available within the process. Thus, NC program restart is not possible through machining sequences that employ tools that are outside the process concerned. The NC generates a corresponding error message in such a situation.

Synchronous and process-internal tool transfer commands

The synchronous tool transfer commands

- TCH (complete tool change between magazine and spindle),
- TMS (tool change between magazine and spindle), or
- TSM (tool change between spindle and magazine)

are used for changing the tools between the tool spindles or tool grippers that belong to a process and the tool storage unit. They permit a (logical and physical) tool change within a process. Machining is not possible as long as they are handled at NC and SPS side (performing a tool change).

During the computing process, the NC does not report the synchronous tool transfer commands to the SPS and does not activate and/or deactivate the tool concerned. The current tools list remains unchanged. Thus, it does not return the tool in the specified spindle back into the tool magazine and does not take the tool from the tool changing position to the specified spindle. However, it remembers the tools that shall be changed in and the spindles into which the tools are to be changed in. Thus it is able to access the correction data of the tool in the current tool spindle in order to calculate the path.

Asynchronous tool transfer commands	<p>Using the standard functions</p> <ul style="list-style-type: none"> • XFER_CHK, XMS, XSM, XMG, XGM, XSG, XGS or • TL_MOVE and/or • TLBD_RD, TLED_RD, TLBD_WR, TLED_WR, TL_ENABL, <p>the SPS can change tools asynchronously to machining and in a process-overlapping fashion.</p>
Asynchronous tool change initiated from the machining program	<p>Asynchronous and process-overlapping tool changes into the tool spindles and tool grippers are usually initiated via the machining program and executed in parallel to the machining process in a cooperation between the SP and an auxiliary process (that usually includes background magazine).</p> <p>Since tool data is missing, an asynchronous tool change that is, for example, initiated via M functions (tool change M functions) in the machining program and is not performed during the NC program restart will result in an error message being issued.</p>
Asynchronous tool change initiated from the SPS	<p>Transferring tools in and out and resorting tools is usually controlled by a separate process (background process), the SPS or an external system, not by the machining process.</p> <p>If, for example, the SPS employs the asynchronous tool changing function to perform a tool change during NC program restart, it modifies the current tools list with this process. Thus, asynchronously loading or unloading a tool storage unit and resorting tools during NC program restart is done like during normal program operation.</p>
T word	<p>During operation, the NC stores the T number last programmed in the T word. Depending on the motion commands MTP and MMP, the NC interprets the T number as a tool number or as a tool location number.</p> <p>During NC program restart, the NC stores the T number under the T address, like in normal operation. It can be read and re-specified in the '.ADJUST' subroutine.</p>

Note: The NC generates an error message if the tool that is selected via the T number is not contained in the current tools list during the computing process.

6 Interface Signals

6.1 NC Program Restart is Active

Designation	PxxSBPACT (NC <u>b</u> lock <u>p</u> reprocessing is <u>a</u> ctive)
Task	The process-related status signal 'NC program restart is active' indicates to the SPS whether or not the NC program restart function is active.
Interpretation	<p>The NC sets this signal only after all the following conditions have been satisfied:</p> <ul style="list-style-type: none"> • The 'ready to start' signal (PxxSREADY=1) is applied for the process. • The controller contains the program that shall be executed. • The program that shall be executed is selected. • Automatic mode (or semi-automatic mode or program execution in setup mode) is selected. • No program is active (PxxSACTIV=0) • The operator has selected NC program restart and properly selected the target block. <p>The NC resets the signal after NC program restart or the related computing process has been performed and/or after NC program restart has been aborted using Stop and Control Reset.</p>
Meaning	<p>NC program restart is active as long as the 'NC program restart is active' signal is '1'. NC program restart is no longer active when the signal assumes the value '0':</p> <p>PxxSBPACT=0: NC program restart is not active PxxSBPACT=1: NC program restart is active</p>

6.2 Starting NC Program Restart (Computing Process)

Designation	PxxCBPSTR (NC <u>b</u> lock <u>p</u> reprocessing <u>s</u> tart)
Task	Setting the process-related control signal 'start of NC program restart' starts the NC program restart or, rather, the computing process proper from the SPS.
Interpretation	The NC only interprets the 'start of NC program restart' if the prerequisites for NC program restart have been fulfilled and if this is announced via the 'NC program restart is active' signal (see above).
Meaning	<p>The NC sets the 'start NC program restart' (positive edge) signal to start NC program restart (provided that the prerequisites for NC program restart have been fulfilled):</p> <p>PxxSBPACT 0 → 1: Activating NC program restart</p>

6.3 Interaction of the Interface Signals

Overview

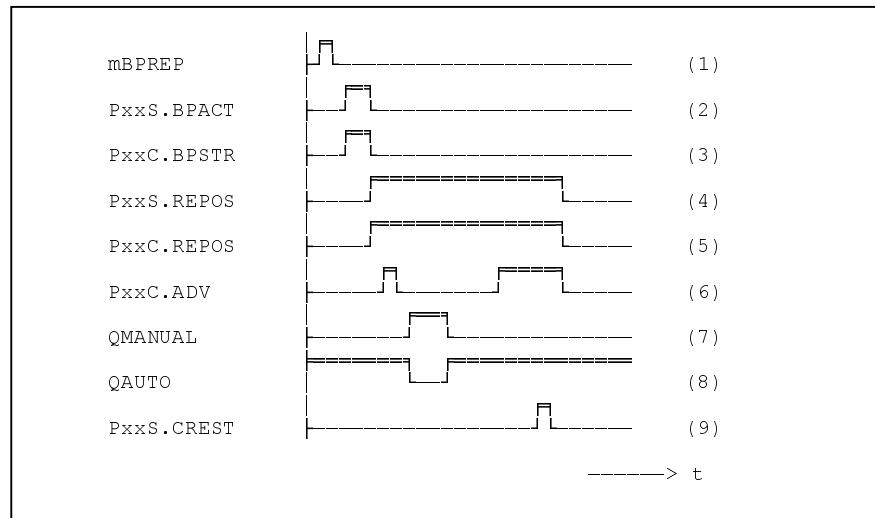

Figure 6-8: Interaction of the relevant signals for NC program restart and subsequent multi-block retrace

- | | |
|--|--|
| Displaying the NC program restart screen | (1) The user interface displays the NC program restart screen when the M key 'NC program restart' (mBPREP) is pressed. |
| NC program restart is active | (2) Provided that the operator has properly selected the start block and the target block, the controller sets the 'NC program restart is active' (PxxSBPACT), status signal when the screen is exited. |
| Starting NC program restart (computing process) | (3) Once NC program restart is active, the SPS automatically sets the process-related 'start NC program restart' (PxxCBPSTR) control signal to start the computing process proper. |
| NC program restart terminated | (4) Once the target block has been reached, the NC resets the 'NC program restart is active' (PxxSBPACT) signal. At the same time, it sets the 'multi-block retrace/return to contour possible' (PxxC.REPOS) interface signal. |
| Activating multi-block retrace | (5) As soon as the NC reports 'multi-block retrace/return to contour possible', the SPS sets the 'multi-block retrace' (PxxCREPOS) interface signal to activate repositioning to the contour. |
| Starting the ADJUST subroutine | (6) When the Start key (PxxCADV) is pressed, the NC starts with executing the ADJUST subroutine. |
| Changeover to manual mode | (7) At the end of the ADJUST subroutine, manual mode (QMANUAL) is selected using an auxiliary function. |
| Changeover to automatic mode | (8) Reselect automatic mode (QAUTO) after you have adjusted the axes such that interference is not possible even in exceptions (such as inside machining or back cutting) |

Starting the REPOS subroutine	(6) When the start key (PxxCADV) is pressed, the NC starts processing the REPOS subroutine, establishing the states that are required for the subsequent machining (starting the NC program at the selected target block).
Required state established	(9) As soon as all axes have been adjusted, the NC sets the 'state before interruption re-established' interface signal to report this state, and automatically continues program execution.

6.4 Behavior of the Interface Signals

Basics With a few exceptions, the NC processes the interface signals in the same fashion as it does in automatic mode. The exceptions are described in the following sections.

Axis Control Signals

Axis ready for operation	Albeit the NC does not take the 'axis ready' (AxxCREADY) axis control signal into consideration during the computing process, it transfers it, combined with further conditions, to the SPS as the 'controller enabling' status signal (AxxSRF), like in normal program mode.
Position strobe	The NC does not process the PMP and NMP commands during NC program restart. Thus, the 'position strobe' (AxxCSTRBP) signal will not be considered.
Motion hold	The NC ignores the motion hold (AxxCMHOLD) signal during the computing process.
Changing gears	The gear step bits (AxxCGEAR1, AxxCGEAR2, AxxCGEAR3) that are sent from the SPS remain unconsidered during the computing process. This is also true if a multi-step gearbox must be switched during the computing process. In this process, the NC performs the programmed gear shift only logically. During the computing process and up to the next gear shift (Mj40 through Mj44; with j = 1, 2 or 3) it accesses the data of the logically activated gear step.
Spindle command speed reached	The spindle speed is not changed during NC program restart. During the computing process, the NC does not consider the 'spindle command speed reached' (AxxCN_CMD) axis control signal, which it interprets for external spindles. With the corresponding spindle control commands it does not wait for the 'spindle command speed reached' signal but continues program interpretation without interruption.
Override	The NC does not consider the override signals (PxxCFOVRD, PxxCROVRD) during the computing process. In contrast, the NC takes the axis-specific override (AxxCOVRD) with spindles and NC-controlled tool storage axes into account when the user moves the NC-controlled tool storage axis during the computing process in manual mode.

Process / Mechanism Control Signals

Minimizing the torsion torque	The NC does not interpret the 'minimize torsion torque' (PxxCSS1MT, PxxCSS2MT) signals during the computing process.
Override	The NC does not consider the override signals (PxxCFOVRD, PxxCROVRD) during the computing process.
Spindle synchronization	The activation of main spindle synchronization during the computing process must be suppressed using the related interface signals (PxxCSS1ON, PxxCSS2ON). main spindle synchronization must be switched off at the beginning of the computing process. The synchronization between the spindles involved must be established in the '.ADJUST' subroutine.
Tracking	Tracking is switched on/off during the computing process using the interface signals (PxxCSCON1, PxxCSCON2, PxxCSCON3, PxxCSCON4) like in normal operation. The slave compound must be resolved in the '.ADJUST' subroutine before the slave axes are adjusted. Next, the axes must be adjusted. Finally, the slave compound must be re-activated.

Axis Status Signals

Waypoints	Like in normal operation, the NC updates the waypoint signals AxxSWP0 through AxxSWP7 by comparing the individual waypoints with the current actual position. Since, during NC program restart, a change of the actual axis positions can only be caused by external influence, the states of the waypoint signals only change when the axes are forcibly moved
Spindle signals	The NC transfers the spindle-related AxxSLD90, AxxSSYNC, AxxSN_CMD, AxxSN_MIN, AxxSMD_DX, AxxSN_MAX, AxxSINPOS and AxxSP_PX status signals to the SPS like in normal operation. During NC program restart, however, the NC does not move the spindle drive.
Motion announcement	The NC does not process the motion announcement signals (AxxSMCPOS, AxxSMCNEG) during the computing process. At the beginning of the computing process, the NC sets these signals to '0' and updates them after NC program restart has been deselected.
In-position window	During NC program restart, the 'in-position window' (AxxSPOSWN) status signal is related to the last command position that was specified before NC program restart was switched on.

Process / Mechanism Status Signals

Tool life monitoring	During the computing process, the NC modifies the data of the current tools list only during the automatic equipment check. As a result, it modifies the status signals that are used for indicating the tool life count (PxxSMGWRN, PxxSMGTWO) only during the automatic equipment check.
-----------------------------	--

6.5 Standard Functions and Function Blocks

Basics During NC program restart, the standard functions and standard function blocks show, with a few exceptions, the same behavior as during automatic mode. The exceptions are described below.

Auxiliary Functions: During the computing process, the standard functions that are used for interrogating the M, Q, S, T and E functions (M_FKT, Q_FKT, S_FKT, T_FKT, E_FKT, M_ALL, Q_ALL, S_ALL, T_ALL, E_ALL, M_NR, Q_NR, S_NR, T_NR, E_NR) do not signal any auxiliary function that is to be processed if the related 'M, Q, S and T/E function output during NC program restart' process parameters were set to NO.

If the machine manufacturer sets the 'M, Q, S and T/E function output during NC program restart' process parameters to YES, the standard functions that are used for interrogating the M, Q, S, T and E functions report the auxiliary functions that are to be processed in the same way as during normal program mode.

Spindle with rotary axis capability During the computing process, the NC does not update the standard functions that are used for selecting spindle mode or rotary axis mode (SPMOD, ROTMOD). For each spindle, it stores the mode last selected in the 'rotary axis mode for spindle 1/2/3' data elements of the machine data on the 'NC program restart' page during the computing process.

Combined spindle/turret axis During the computing process, the NC does not update the standard functions that are used for selecting spindle mode or turret mode (MAG_ACT, SPDL_ACT). It does not store the mode either because turret mode only exists briefly as long as the turret is swiveled.

7 Examples

7.1 Simple Milling Machine

Task NC program restart including multi-block retrace must be commissioned for a simple milling machine (see figure below).

Structure of the milling machine

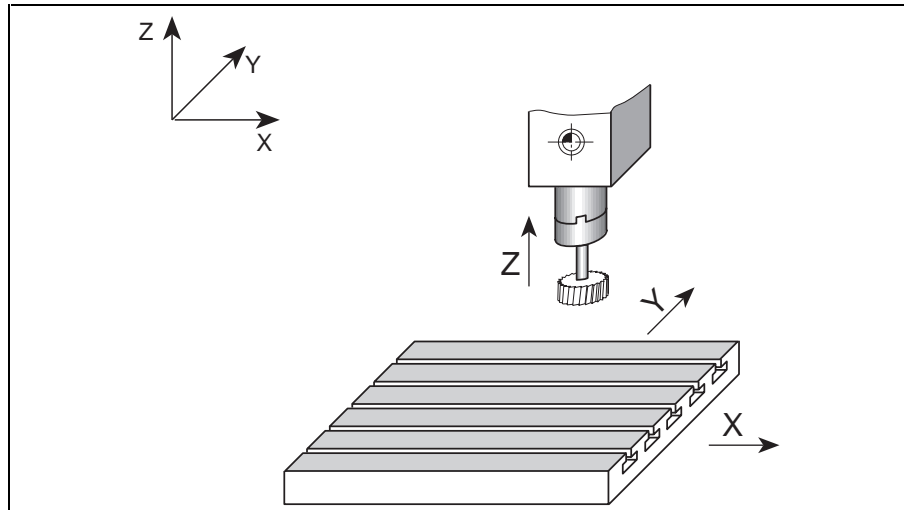

Figure 7-9: Structure of the milling machine

The milling machine mainly consists of a horizontal table that is moved along the two axes X and Y. The vertically arranged Z axis moves the tool perpendicularly to the table. Furthermore, there is a spindle that accommodates the tools. A double gripper fetches the tools from an SPS-controlled tool magazine with 24 locations.

S, T and M functions are employed for the operation of this milling machine. All M functions are assigned to the groups 1 through 15.

Parameter value assignment	Bxx.058 M function output during NC program restart	No
	Bxx.059 Q function output during mid-program startup	No
	Bxx.061 S function output during mid-program startup	No
	Bxx.061 T/E function output during mid-program startup	No

Configuring the M keys You must select manual mode at the end of the 'ADJUST' subroutine. This enables the operator at the beginning of the multi-block retrace process to approach the axes to the workpiece such that interferences can be excluded during the subsequent automatic adjustment.

During manual mode, the operator should be provided with the same M key level as during NC program restart (level 4, see figure below) in automatic mode. Using the global flags, a second manual mode screen is introduced for this purpose. In contrast to the first one, this second screen invokes M key level 4. The second manual mode screen is triggered via the mMANUAL2 auxiliary flag (see the screens that are shown below).

Pg ▲ Station: 0 SPS program name: VMC32A04

Identifier	Level	Act. Nr.	Name for Sub-Oper. Mode	Screen Nr.	Name for Main Oper. Mode
mMANUAL1	1	0		1	MANUAL
QAUTO	2	0		2	AUTO
QMDI	0	0		3	MDI
QSEMI	0	0		2	SEMI
ARTALARM	0	90		-	
MFEHL	0	90		-	
mMANUAL2	4	0		1	HAND
QSTEP	7	-		-	
mQistw 0	-	5		-	
mQistw r	-	6		-	
	-	-		-	
	-	-		-	
	-	-		-	
	-	-		-	

Modify

Identif. Catalog F5 Screen. Catalog F6 Action Catalog F7 ← F8

Figure 7-10: Entering the global flags

Pg ▲ Level 02 SPS program name: VMC32A04 Block-prepar.

Identifier Softkey	Identifier Softkey pressed	Identifier Softkey active (ON)	Next Level	Act. Nr.	Name for Sub-Operating Mode
mBPREP	mBPREP	mBPREP	04	67	
	SK4	SK4	02	7	
mBLSKP	mBLSKP	.BLSKP	02	00	
mM001	mM001	P00C.M001	02	00	
mNTC	mNTC	.MGNTC	02	00	
	SK8	SK8	0	00	

Modify

Level F4 Identif. Catalog F5 Name Keys F6 Action Catalog F7 ← F8

Figure 7-11: Entering the M key 'NC program restart'

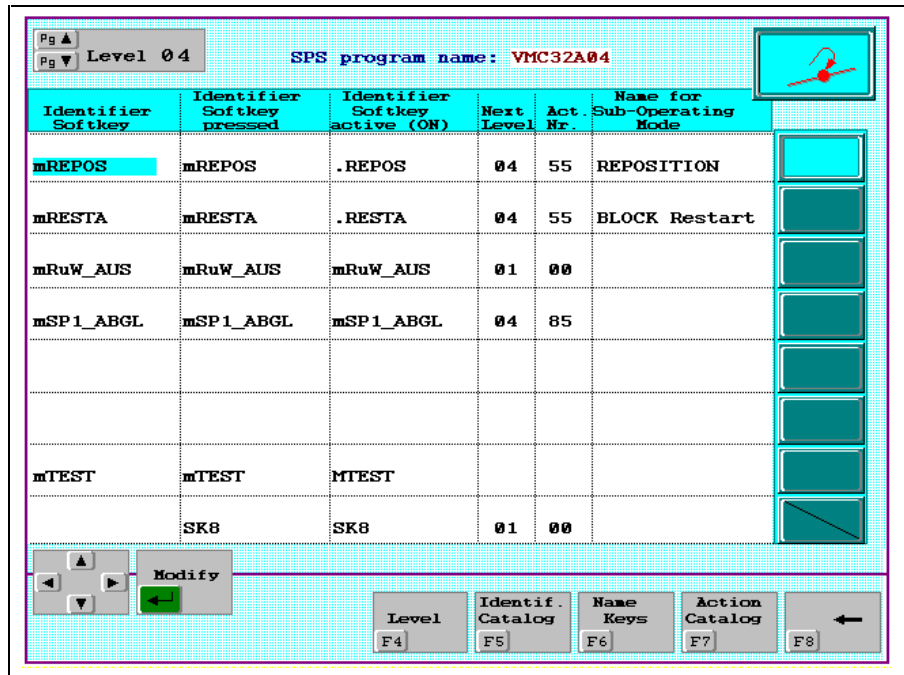

Figure 7-12: Entering the M key 'REPOS'

SPS program segment for NC program restart

The following figure shows the SPS program segment that is used for implementing the NC program restart.

NC program restart

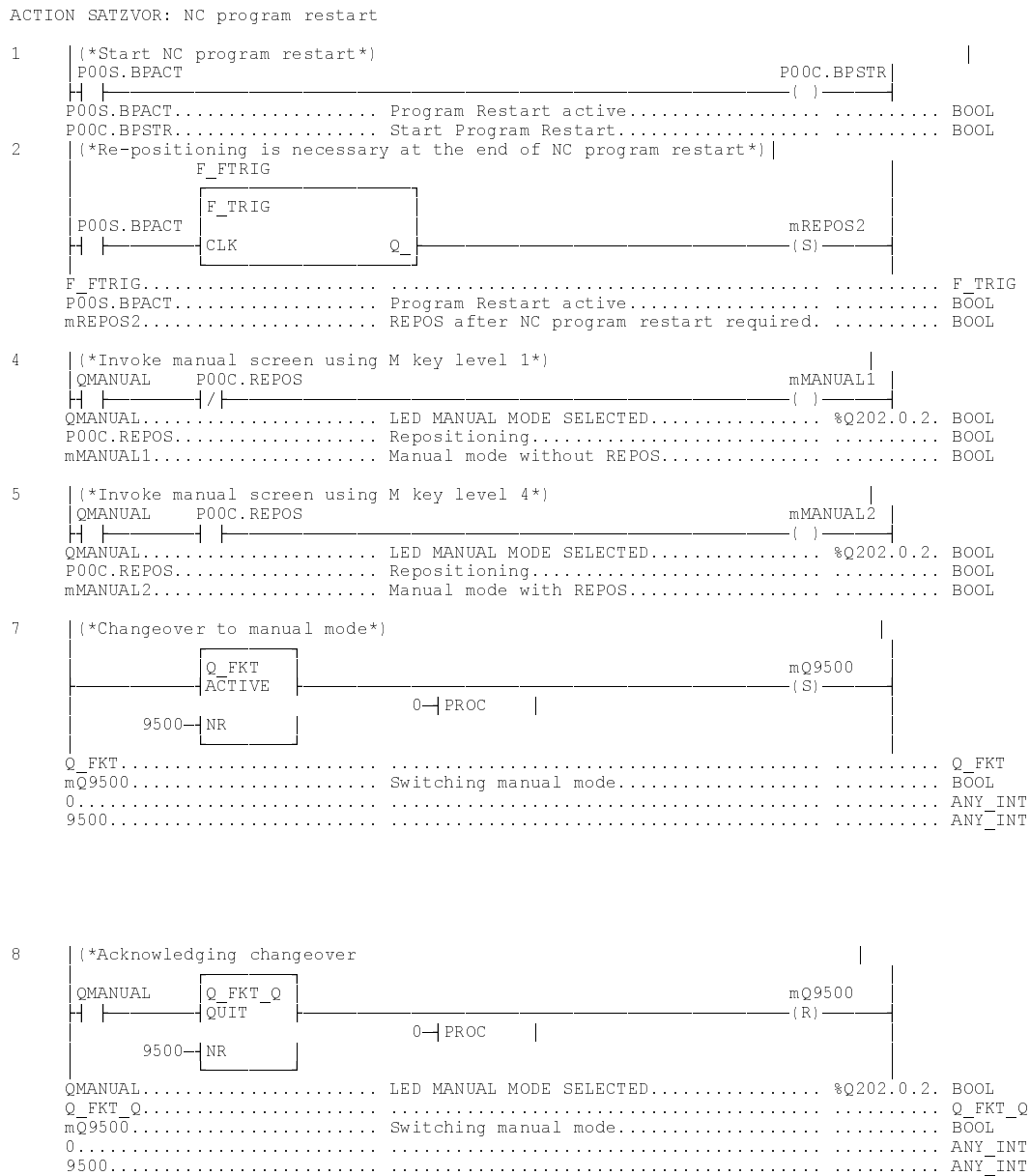

Figure 7-13: SPS program segment for NC program restart

Expansion in the REPOS-SPS program segment

An existing REPOS-SPS segment must be expanded in conjunction with NC program restart. In the following example, all major modifications are highlighted and marked with a '>'.</p>
</div>

DOK-MTC200-SATZVOR*V18-ANW1-EN-P

REPOS

ACTION aREPOS: REPOSITIONING, RETURN TO CONTOUR

```

1 | (*Repositioning and return to contour permitted*) |
  | POOS.REPOS POOS.CREST mRuW_AUS | mRuW_OK |
  |-----|/|-----|/|-----|-----|-----|
  | POOS.REPOS..... Repositioning/Restart allowed..... BOOL
  | POOS.CREST..... Conditions restored..... BOOL
  | mRuW_AUS..... REPOS./RETURN TO CONTOUR OFF..... BOOL
  | mRuW_OK..... Enable repositioning/return to contour.. BOOL
>
> 2 | (*Reset flag for REPOS after NC program restart |
  | POOC.REPOS | mREPOS2 |
  |-----|-----|-----|-----|-----|
  | POOC.REPOS..... Repositioning..... BOOL
  | mREPOS2..... REPOS after NC program restart required. .... BOOL
>
>
4 | (*REPOSITIONING*) |
  | mREPOS mRuW_OK mRESTA | POOC.REPOS |
  |-----|/|-----|-----|-----|
  | mREPOS2 |
  |-----|
  | POOC.REPOS |
  |-----|
  | mREPOS..... REPOSITIONING..... BOOL
  | mRuW_OK..... Enable repositioning/return to contour.. BOOL
  | mRESTA..... RETURN TO CONTOUR..... BOOL
  | POOC.REPOS..... Repositioning..... BOOL
  | mREPOS2..... REPOS after NC program restart required. .... BOOL
  | POOC.REPOS..... Repositioning..... BOOL
>
>
5 | (*RETURN TO CONTOUR*) |
  | mRESTA mRuW_OK mREPOS | POOC.RESTA |
  |-----|/|-----|-----|-----|
  | POOC.RESTA |
  |-----|
  | mRESTA..... RETURN TO CONTOUR..... BOOL
  | mRuW_OK..... Enable repositioning/return to contour.. BOOL
  | mREPOS..... REPOSITIONING..... BOOL
  | POOC.RESTA..... Restart..... BOOL
  | POOC.RESTA..... Restart..... BOOL
>
>
6 | (*Triggering the screen*) |
  | POOC.REPOS | mRuW_BLD |
  |-----|-----|-----|-----|
  | POOC.RESTA |
  |-----|
  | POOC.REPOS..... Repositioning..... BOOL
  | mRuW_BLD..... BILDSCH.FUER R.+W..... BOOL
  | POOC.RESTA..... Restart..... BOOL
>
>
7 | (*ADJUSTMENT S1 M3*) |
  | mA04CM3 mRuW_OK mSP1_ABGL | MREPOS3 |
  |-----|/|-----|-----|-----|
  | mA04CM3..... ADJUSTMENT S1 M3..... BOOL
  | mRuW_OK..... Enable repositioning/return to contour. .... BOOL
  | mSP1_ABGL..... Adjustment spindle 1..... BOOL
  | MREPOS3..... M start spindle RePos M3..... BOOL
>
>
8 | (*ADJUSTMENT S1 M4*) |
  | mA04CM4 mRuW_OK mSP1_ABGL | MREPOS4 |
  |-----|/|-----|-----|-----|
  | mA04CM4..... ADJUSTMENT S1 M4..... BOOL
  | mRuW_OK..... Enable repositioning/return to contour. .... BOOL
  | mSP1_ABGL..... Adjustment spindle 1..... BOOL
  | MREPOS4..... M start spindle RePos M4..... BOOL
>
>
9 | (*ADJUSTMENT S1 M5*) |
  | mA04CM5 mRuW_OK mSP1_ABGL | MREPOS5 |
  |-----|/|-----|-----|-----|
  | mA04CM5..... ADJUSTMENT S1 M5..... BOOL
  | mRuW_OK..... Enable repositioning/return to contour. .... BOOL
  | mSP1_ABGL..... Adjustment spindle 1..... BOOL
  | MREPOS5..... M start spindle RePos M5..... BOOL
>
>
10 | (*ADJUSTMENT S1 M19*) |
  | mA04CM19 mRuW_OK mSP1_ABGL | MREPOS19 |
  |-----|/|-----|-----|-----|
  | mA04CM19..... ADJUSTMENT S1 M19..... BOOL
  | mRuW_OK..... Enable repositioning/return to contour. .... BOOL
  | mSP1_ABGL..... Adjustment spindle 1..... BOOL
  | MREPOS19..... M start spindle RePos M19..... BOOL

```

7.2 Turning Center

Task NC program restart including multi-block retrace (repositioning) shall be commissioned for a turning center (see figure below).

Structure of the turning center

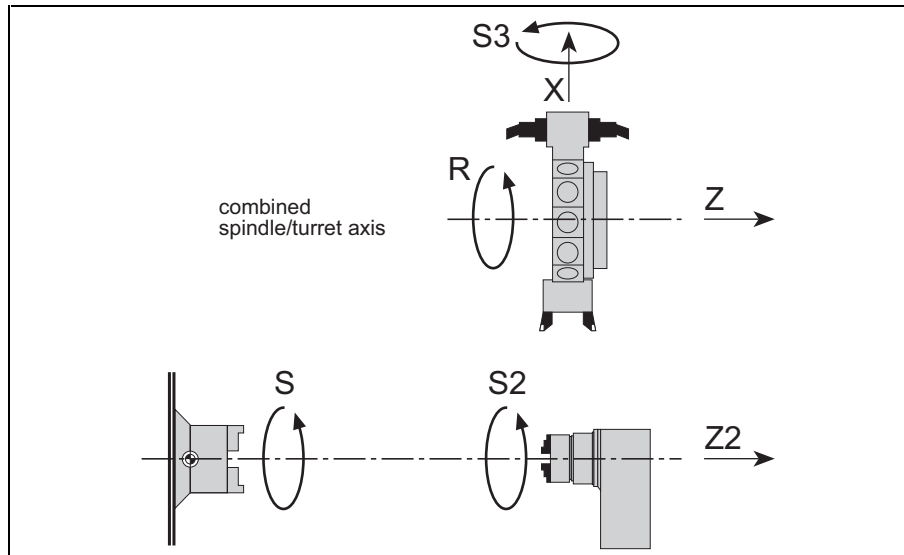

Figure 7-16: Structure of the turning center

The turning center mainly consists of a main spindle S and a counter spindle (S2) that is moved using a secondary axis Z2, and an X axis and a Z axis that move the turret. During the machining process, the workpieces are transferred from the first spindle (S) to the counter spindle (S2) where they are finished. Furthermore, there is a combined spindle/turret axis (R/S3) for the turret with 12 locations. Driven tools (twin tools) can be programmed using the address S3.

Parameter value assignments		
Bxx.058	M function output during NC program restart	Yes
Bxx.059	Q function output during mid-program startup	No
Bxx.060	S function output during mid-program startup	No
Bxx.061	T/E function output during mid-program startup	No

Parts transfer is implemented on the machine data page, in the SPS program, in the ADJUST and REPOS subroutines, and in the subroutine for the parts transfer (see figures below) .

Machine data page for parts transfer

The 'direction S1<>S2' and 'Position Z2 axis' elements are accessed via the machine data page.

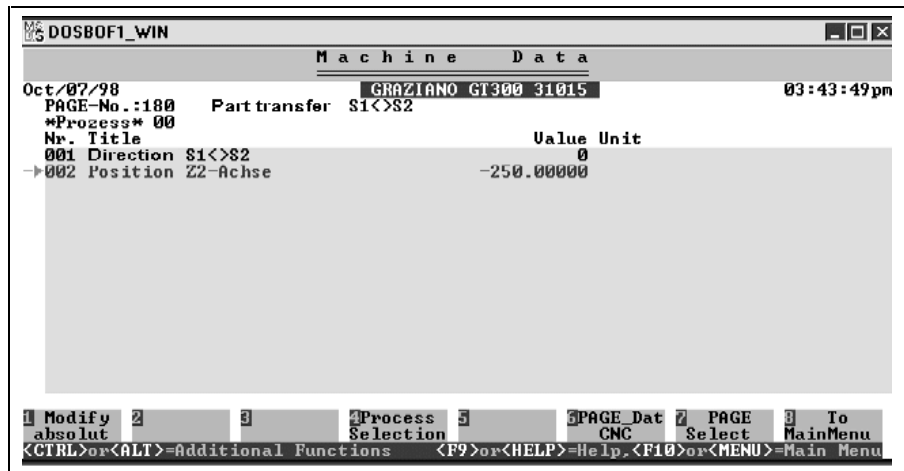

Figure 7-17: Machine data page for parts transfer

Function block used for initializing the parts transfer

The MTD_WR function block is used for writing the machine data for the part transfer in the SPS program.

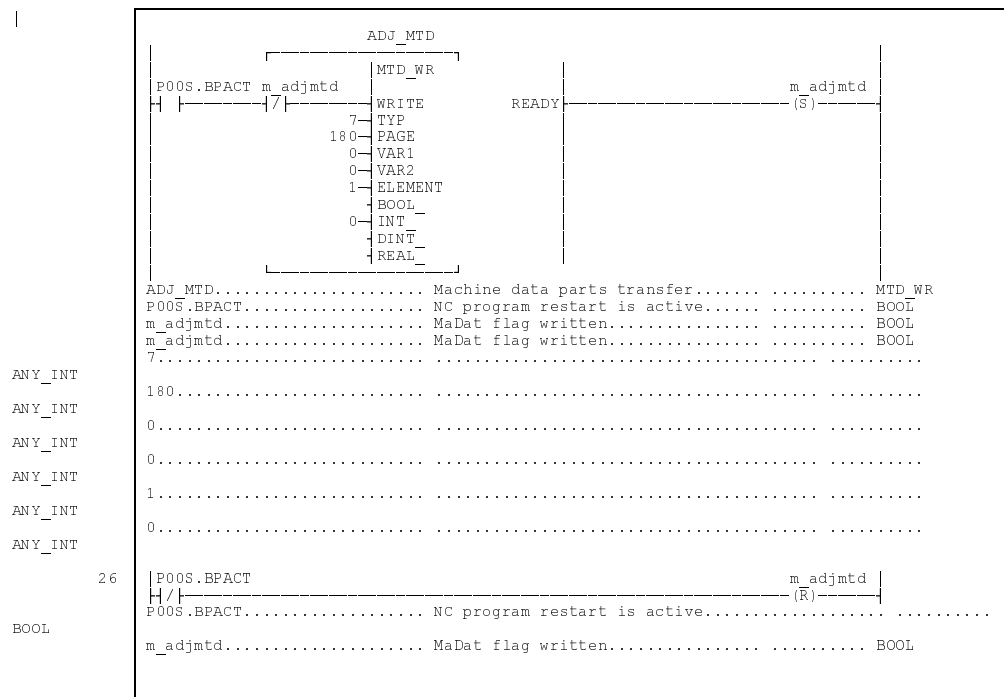

Figure 7-18: SPS function block for parts transfer

**ADJUST and REPOS
subroutines**

The states required for program entry are established in the ADJUST and REPOS subroutines. The workpiece transfer between spindle 1 and spindle 2 is processed in the 'parts transfer' subroutine.

```

%MAC:0:03:0:030
!01.00
#
$
$
$
$
$
*ADJUST - REPOS - RESTA
%MAC
;----- .ADJUST -----
N0000 .ADJUST
; Default values for ADJUST and REPOS
N0001 @105=0 ; Tracking flag
N0002 @106=0 ; Spindle synchronization flag
;
;----- Changing tools -----
N0003 @100=M(4)
N0004 T=MTD(60,,,5) ; Reading tool number
N0005 MTP ; Changing tools
N0006 MRY
N0007 M=@100
;
;----- Parts transfer S1<>S2 -----
N0008 @100=MTD(180,,,1) BEQ .KWSTWE ; Parts transfer necessary
N0009 @100=@141 @101=@142 ; Buffering the variables and
N0010 @102=S @103=S2 ; spindle speeds fir parts transfer
N0011 @141=MTD(180,,,1) ; Reading direction and position from
N0012 @142=MTD(180,,,2) ; machine data user page
N0013 BSR .*WSTCH ; Parts transfer subroutine call
N0014 @141=@100 @142=@101 ; Backup of variablea and
N0015 S=@102 S2=@103 ; spindle speeds
N0016 .KWSTWE
;
;----- Output of M auxiliary functions -----
N0017 @100=1 ; Count variable
N0018 .LOOP1
N0019 @110=MTD(61,,1,@100) BEQ .WEIT1 ; Read from machine data
; M group 16
; Skipping M functions that are nor executed
N0020 @101=@110-68 BEQ .MF_NAU
N0021 @101=@110-69 BEQ .MF_NAU
N0022 @101=@110-268 BEQ .MF_NAU
N0023 @101=@110-269 BEQ .MF_NAU
;
; Considering spindle synchronization
N0024 @101=@110-70 BNE .SSKAN
N0025 @106=@110 ; Spindle sync flagON
N0026 BRA .MF_NAU ; Don't execute M function

```

```

N0027 .SSKAN
N0028 @101=@110-71 BNE .SSKAUS
N0029 @106=@110 ; Spindle sync flagOFF
N0030 BRA .MF_NAU ; Don't execute M function
N0031 .SSKAUS
;
; Considering tracking
N0032 @101=@110-270 BNE .MUGAN
N0033 @105=@110 ; Tracking flag ON
N0034 BRA .MF_NAU ; Don't execute M function
N0035 .MUGAN
N0036 @101=@110-271 BNE .MUGAUS
N0037 @105=@110 ; Tracking flag OFF
N0038 BRA .MF_NAU ; Don't execute M function
N0039 .MUGAUS
;
N0040 M=@110 ; Executing remaining M functions
; of group 16

N0041 .MF_NAU
N0042 @100=@100+1
N0043 @101=@100-41 BMI .LOOP1
N0044 .WEIT1
;
;----- Output of Q auxiliary functions -----
N0045 @100=1 ; Count variable
N0046 .LOOP2
N0047 @110=MTD(61,,2,@100) BEQ .WEIT2 ; Read from machine data
; Q group 16
N0048 Q=@110 ; Executing Q functions of
; group 16

N0049 @100=@100+1
N0050 @101=@100-41 BMI .LOOP2
N0051 .WEIT2
;
;----- Setting G code group 17 (transformation) -----
;
N0052 @107=G(1) @108=G(3) ; Buffering the active
interpolation,
N0053 @109=G(4) @110=G(13) ; tool path compensation
; Zero point shifts
; Tool length compensation
N0054 @101=MTD(60,,4)-32 BEQ .G32TRA ; G32 interrogation active
N0055 G=@101+32 ; Setting G30 or G31
N0056 BRA .WEIT4
;
; Setting prerequisites for G32
N0057 .G32TRA
N0058 @100=SPC-1 BEQ .G32SP1 ; Interrogating the reference
spindle
; Reference spindle 2
N0059 G18 ; Resetting G20
N0060 @100=G(6) @101=G(1) ; Buffering the G groups
; Interpolation, dimension
N0061 G91 G00 C2 0 ; Switching to rotary axis mode
N0062 G=@100 G=@101 ; Backup of G groups

```

```

N0063 G20 Z0 C2 0 X0 ; Setting G20 for spindle 2
N0064 BRA .G32UMS
N0065 .G32SP1 ; Reference spindle 1
N0066 G18 ; Resetting G20
N0067 @100=G(6) @101=G(1) ; Buffering the G groups
; Interpolation, dimension
N0068 G91 G00 C0 ; Switching to rotary axis mode
N0069 G=@100 G=@101 ; Backup of G groups
N0070 G20 Z0 C0 X0 ; Setting G20 for spindle 1
N0071 .G32UMS
N0072 G32 ; Activating G32
;
N0073 .WEIT4
N0074 G=@107 G=@108 ; Backup of G groups
N0075 G=@110 ; G(1), G(3), G(4), G(13)
N0076 G=@109
;
; Deactivating tracking before REPOS
N0077 @101=@105-270 BNE .KEIMG3 ; Tracking interrogation active
N0078 M271 ; Tracking OFF
N0079 .KEIMG3
;
;----- Switching to manual mode-----
N0080 Q9500 ; Switch to manual mode via SPS
;
; -----
;----- .REPOS -----
N0081 .REPOS
;
;----- Continue in automatic mode -----
;
;----- Repositioning spindle 3 -----
;
N0082 @100=M(4)-305 BEQ .SP3END
N0083 G77 S3 0
N0084 .SP3END
;
N0085 @101=@106-71 BNE .NSYAUS ; Switch off sync interrogation
N0086 M71
N0087 .NSYAUS
;
;----- Spindle positioning depending G(17) -----
;
N0088 @100=MTD(60,,,4)-30 BEQ .WEIT11 ; G30 interrogation active
;
N0089 @101=SPC-1 BEQ .BEZSP2 ; Interrogation transformation
spindle 1
;
N0090 @101=MTD(60,,,1) BEQ .SP1POS ; Approaching spindle 1
N0091 G77 C0 F5000 ; Spindle 1 in rotary axis mode
N0092 BRA .TRANS2
N0093 .SP1POS
N0094 G77 S0 ; Spindle 1 in spindle mode
;

```

```

; ----- Transformation spindle 2 -----
N0095 .TRANS2
N0096 @101=MTD(60,,,4)-31 BEQ .S2_G32 ; G32 interrogation active
;
N0097 G77 X0 Y2 0 F5000 ; Adjustment of spindle 2 for G31
N0098 G77 Z0 F5000 ; Adjustment of Z axis
N0099 G77 Z2 0 F5000 ; Adjustment of Z2 axis
N0100 BRA .TRAAKT
;
N0101 .S2_G32 ; Adjustment of spindle 2 for G32
N0102 G77 Y2 0 F5000 ; Adjustment of Y2 axis
N0103 G77 Z0 F5000 ; Adjustment of Z axis
N0104 G77 Z2 0 F5000 ; Adjustment of Z2 axis
N0105 G77 X0 F5000 ; Adjustment of X axis
;
N0106 BRA .TRAAKT
;
N0107 .BEZSP2
N0108 @101=MTD(60,,,2) BEQ .SP2POS ; Approaching spindle 2 position
N0109 G77 C2 0 F5000 ; Spindle 2 in rotary axis mode
N0110 BRA .TRANS1
N0111 .SP2POS
N0112 G77 S2 0 ; Spindle 2 in spindle mode
;
; ----- Transformation spindle 1 -----
N0113 .TRANS1
N0114 @101=MTD(60,,,4)-32 BEQ .S1_G32 ; G32 interrogation active
;
N0115 G77 X0 Y1 0 F5000 ; Adjustment of spindle 1 for G31
N0116 G77 Z0 F5000 ; Adjustment of Z axis
N0117 G77 Z2 0 F5000 ; Adjustment of Z2 axis
N0118 BRA .TRAAKT
;
N0119 .S1_G32 ; Adjustment of spindle 1 for G32
N0120 G77 Y1 0 F5000 ; Adjustment of Y1 axis
N0121 G77 Z0 F5000 ; Adjustment of Z axis
N0122 G77 Z2 0 F5000 ; Adjustment of Z2 axis
N0123 G77 X0 F5000 ; Adjustment of X axis
;
N0124 BRA .TRAAKT
N0125 .WEIT11
;
;----- Adjusting spindle 1 and spindle 2 -----
--
;
N0126 @100=MTD(60,,,1)+MTD(60,,,2) BEQ .SPMOD ; Both spindles in S mode
;
N0127 @101=MTD(60,,,1) BEQ .S1SMOD ; Approaching spindle 1 position
N0128 G77 C0 F5000 ; Spindle 1 in rotary axis mode
N0129 BRA .S2ABG
N0130 .S1SMOD
N0131 G77 S0 ; Spindle 1 in spindle mode
;
N0132 .S2ABG

```

```

N0133 @I01=MTD(60,,,2) BEQ .S2SMOD ; Approaching spindle 2 position
N0134 G77 C2 0 F5000 ; Spindle 2 in rotary axis mode
N0135 BRA .RUMOD
N0136 .S2SMOD
N0137 G77 S2 0 ; Spindle 2 in spindle mode
N0138 BRA .RUMOD
;
N0139 .SPMOD
;
N0140 @I01=@I06-70 BNE .NSYNCH ; Activating sync interrogation
N0141 M=M(2) ; Spindle 1 in S mode
N0142 M=M(3) ; Spindle 2 in S mode
N0143 G77 S0 S2 0 M70 ; Establishing synchronization
N0144 BRA .RUMOD
N0145 .NSYNCH
N0146 G77 S0 S2 0 ; Adjustment spindle 1 and spindle 2
;
N0147 .RUMOD
;
;----- Repositioning axes -----
;
N0148 G77 X0 F5000 ; Adjustment of X axis
N0149 G77 Z0 F5000 ; Adjustment of Z axis
N0150 G77 Z2 0 F5000 ; Adjustment of Z2 axis
;
N0151 .TRAAKT
;
N0152 @I01=@I05-270 BNE .KEIMG2 ; Tracking interrogation active
N0153 M270 ; Tracking ON
N0154 .KEIMG2
;
;
N0155 RTS
N0156 RTS

```

Figure 7-19: ADJUST and REPOS subroutines

NC subroutine for parts transfer

```

%MAC:0:03:0:019
!01.00
#
$
$
$
$
$
*Parts transfer S1<>S2
%MAC
%CHBEGIN%
%V% @I41 INT[1,2] parts transfer S2>S1 (1) S1>S2 (2)
%V% @I42 REAL[-450,-0.1] transfer position Z2 axis
%N% BSR .*WSTCH ;cycle call
%CHEND%
;*****
;*** Cycle : Cycle name ***
;*** Label : .xxxxx ***
;*****

```

```
;
N0000 .*WSTCH
N0001 MTD(180,,,1)=@141 ; Direction
N0002 MTD(180,,,2)=@142 ; Position
N0003 @101=G(4)
;
N0004 @100=@141-2 BEQ .*WSTS2
; Part transferred in 1st spindle
N0005 M=69
N0006 G4 F.2
N0007 M10
N0008 S20 M3
N0009 G4 F2
N0010 M5
N0011 M11
N0012 G4 F.2
N0013 G53 G0 Z2=@142
N0014 M=68
N0015 G4 F1
N0016 M269
N0017 G4 F.5
N0018 G0 Z2 1
N0019 BRA .*WSTEN
;
N0020 .*WSTS2
; Part transferred in spindle 2
N0021 M269
N0022 G4 F.2
N0023 M10
N0024 S2 20 M203
N0025 G4 F2
N0026 M205
N0027 M11
N0028 G4 F.2
N0029 G53 G0 Z2=@142
N0030 M268
N0031 G4 F1
N0032 M=69
N0033 G4 F.5
N0034 G0 Z2 1
;
N0035 .*WSTEN
N0036 G=@101
;
N0037 RTS
N0038 RTS
```

Figure 7-20: NC subroutine for parts transfer

Kundenbetreuungsstellen - Sales & Service Facilities

Deutschland - Germany

Germany Center <input checked="" type="checkbox"/> V/S <input checked="" type="checkbox"/> Service	Vertriebsgebiet Ost Germany East <input checked="" type="checkbox"/> V/S <input checked="" type="checkbox"/> Service	Vertriebsgebiet West Germany West <input checked="" type="checkbox"/> V/S <input checked="" type="checkbox"/> Service	Vertriebsgebiet Nord Germany North <input checked="" type="checkbox"/> V/S <input type="checkbox"/> Service
INDRAMAT GmbH Bgm.-Dr.-Nebel-Str. 2 D - 97816 Lohr am Main Phone: +49 (0)9352/40-0 Fax: +49 (0)9352/40-4885	INDRAMAT GmbH Beckerstraße 31 D - 09120 Chemnitz Phone: +49 (0)371/35 55-0 Fax: +49 (0)371/35 55-333	INDRAMAT GmbH Harkortstraße 25 D - 40849 Ratingen Phone: +49 (0)2102/43 18-0 Fax: +49 (0)2102/41 315	INDRAMAT GmbH Kieler Straße 212 D - 22525 Hamburg Phone: +49 (0)40/85 31 57-0 Fax: +49 (0)40/85 31 57-15
Vertriebsgebiet Süd Germany South <input checked="" type="checkbox"/> V/S <input type="checkbox"/> Service	Gebiet Südwest Germany South-West <input checked="" type="checkbox"/> V/S <input checked="" type="checkbox"/> Service		INDRAMAT Service-Hotline INDRAMAT GmbH Phone: +49 (0)172/660 04 06 or Phone: +49 (0)171/333 88 26
INDRAMAT GmbH Ridlerstraße 75 D-80339 München Phone: +49 (0)89/540138-30 Fax: +49 (0)89/540138-10	INDRAMAT GmbH Böblinger Straße 25 D-71229 Leonberg Phone: +49 (0)7152/9 72-6 Fax: +49 (0)7152/9 72-727		

Kundenbetreuungsstellen in Deutschland - Service agencies in Germany

Europa - Europe

<p>Austria <input checked="" type="checkbox"/> V/S <input type="checkbox"/> Service</p> <p>Mannesmann Rexroth Ges.m.b.H. Geschäftsbereich INDRAMAT Hägelingasse 3 A - 1140 Wien</p> <p>Phone: +43 (0)1/9852540-400 Fax: +43 (0)1/9852540-93</p>	<p>Austria <input type="checkbox"/> V/S <input checked="" type="checkbox"/> Service</p> <p>Mannesmann Rexroth G.m.b.H. Geschäftsbereich INDRAMAT Industriepark 18 A - 4061 Pasching</p> <p>Phone: +43 (0)7221/605-0 Fax: +43 (0)7221/605-21</p>	<p>Belgium <input checked="" type="checkbox"/> V/S <input checked="" type="checkbox"/> Service</p> <p>Mannesmann Rexroth N.V.-S.A. Geschäftsbereich INDRAMAT Industrielaan 8 B-1740 Ternat</p> <p>Phone: +32 (0)2/5823180 Fax: +32 (0)2/5824310</p>	<p>Denmark <input checked="" type="checkbox"/> V/S <input checked="" type="checkbox"/> Service</p> <p>BEC AS Zinkvej 6 DK-8900 Randers</p> <p>Phone: +45 (0)87/11 90 60 Fax: +45 (0)87/11 90 61</p>
<p>United Kingdom <input checked="" type="checkbox"/> V/S <input checked="" type="checkbox"/> Service</p> <p>Mannesmann Rexroth Ltd. INDRAMAT Division 4 Esland Place, Love Lane GB - Cirencester, Glos GL7 1YG</p> <p>Phone: +44 (0)1285/658671 Fax: +44 (0)1285/654991L†</p>	<p>Finland <input checked="" type="checkbox"/> V/S <input type="checkbox"/> Service</p> <p>Rexroth Mecman OY Ansatie 6 SF-017 40 Vantaa</p> <p>Phone: +358 (0)9/84 91 11 Fax: +358 (0)9/84 91 13 60</p>	<p>France <input checked="" type="checkbox"/> V/S <input checked="" type="checkbox"/> Service</p> <p>Mannesmann Rexroth S.A. Division INDRAMAT Parc des Barbanniers 4, Place du Village F-92632 Gennevilliers Cedex</p> <p>Phone: +33 (0)141 47 54 30 Fax: +33 (0)147 94 69 41 Hotline: +33 (0)6 08 33 43 28</p>	<p>France <input checked="" type="checkbox"/> V/S <input type="checkbox"/> Service</p> <p>Mannesmann Rexroth S.A. Division INDRAMAT 270, Avenue de Lardenne F - 31100 Toulouse</p> <p>Phone: +33 (0)5 61 49 95 19 Fax: +33 (0)5 61 31 00 41</p>
<p>France <input checked="" type="checkbox"/> V/S <input type="checkbox"/> Service</p> <p>Mannesmann Rexroth S.A. Divisione INDRAMAT 91, Bd. Irène Joliot-Curie F - 69634 Vénissieux Cedex</p> <p>Phone: +33 (0)4 78 78 53 65 Fax: +33 (0)4 78 78 52 53</p>	<p>Italy <input checked="" type="checkbox"/> V/S <input checked="" type="checkbox"/> Service</p> <p>Mannesmann Rexroth S.p.A. Divisione INDRAMAT Via G. Di Vittoria, 1 I - 20063 Cernusco S/N.MI</p> <p>Phone: +39 (0)2/92 36 52 70 Fax: +39 (0)2/92 36 55 12L†</p>	<p>Italy <input checked="" type="checkbox"/> V/S <input checked="" type="checkbox"/> Service</p> <p>Mannesmann Rexroth S.p.A. Divisione INDRAMAT Via Borgomanero, 11 I - 10145 Torino</p> <p>Phone: +39 (0)11/7 71 22 30 Fax: +39 (0)11/7 71 01 90</p>	<p>Italy <input checked="" type="checkbox"/> V/S <input type="checkbox"/> Service</p> <p>Mannesmann Rexroth S.p.A. Divisione INDRAMAT Via del Progresso, 16 (Zona Ind.) I - 35020 Padova</p> <p>Phone: +39 (0)49/8 70 13 70 Fax: +39 (0)49/8 70 13 77</p>
<p>Italy <input type="checkbox"/> V/S <input checked="" type="checkbox"/> Service</p> <p>Mannesmann Rexroth S.p.A. Divisione INDRAMAT Via de Nicola, 12 L† I - 80053 Castellamare di Stabia NA L†</p> <p>Phone: +39 (0)81/8 72 30 37 Fax: +39 (0)81/8 72 30 18</p>	<p>Italy <input checked="" type="checkbox"/> V/S <input type="checkbox"/> Service</p> <p>Mannesmann Rexroth S.p.A. Divisione INDRAMAT Viale Oriani, 38/A I - 40137 Bologna</p> <p>Phone: +39 (0)51/34 14 14 Fax: +39 (0)51/34 14 22</p>	<p>Netherlands <input checked="" type="checkbox"/> V/S <input type="checkbox"/> Service</p> <p>Hydraudyne Hydrauliek B.V. Kruisbroeksestraat 1 P.O. Box 32 NL - 5281 RV Boxtel</p> <p>Phone: +31 (0)411/65 19 51 Fax: +31 (0)411/65 14 83 L†</p>	<p>Netherlands <input type="checkbox"/> V/S <input checked="" type="checkbox"/> Service</p> <p>Hydrocare B.V. Kruisbroeksestraat 1 P.O. Box 32 NL - 5281 RV Boxtel</p> <p>Phone: +31 (0)411/65 19 51 Fax: +31 (0)411/67 78 14 L†</p>
<p>Spain <input checked="" type="checkbox"/> V/S <input checked="" type="checkbox"/> Service</p> <p>Mannesmann Rexroth S.A. Divisione INDRAMAT Centro Industrial Santiga Obradors s/n L† E-08130 Santa Perpetua de Mogoda L† Barcelona</p> <p>Phone: +34 937 47 94 00 Fax: +34 937 47 94 01</p>	<p>Spain <input checked="" type="checkbox"/> V/S <input checked="" type="checkbox"/> Service</p> <p>Goimendi S.A. División Indramat Jolastokieta (Herrera) Apartado 11 37 E - 20017 San Sebastian</p> <p>Phone: +34 9 43/40 01 63 Fax: +34 9 43/39 17 99</p>	<p>Sweden <input checked="" type="checkbox"/> V/S <input checked="" type="checkbox"/> Service</p> <p>Rexroth Mecman Svenska AB INDRAMAT Division Varuvägen 7 S - 125 81 Stockholm</p> <p>Phone: +46 (0)8/727 92 00 Fax: +46 (0)8/64 73 277</p>	<p>Switzerland - East <input checked="" type="checkbox"/> V/S <input checked="" type="checkbox"/> Service</p> <p>Mannesmann Rexroth AG Geschäftsbereich INDRAMAT Gewerbstraße 3 CH-8500 Frauenfeld</p> <p>Phone: +41 (0)52/720 21 00 Fax: +41 (0)52/720 21 11</p>
<p>Switzerland - West <input checked="" type="checkbox"/> V/S <input type="checkbox"/> Service</p> <p>Mannesmann Rexroth SA Département INDRAMAT Chemin de l'Ecole 6 CH-1036 Sullens</p> <p>Phone: +41 (0)21/731 43 77 Fax: +41 (0)21/731 46 78</p>	<p>Russia <input type="checkbox"/> V/S <input checked="" type="checkbox"/> Service</p> <p>Tschudnenko E.B. Arsenia 22 RUS - 153000 Ivanovo Rußland</p> <p>Phone: +7 093/223 96 33 L†oder/orL† +7 093/223 95 48 Fax: +7 093/223 46 01</p>	<p>Slovenia <input checked="" type="checkbox"/> V/S <input checked="" type="checkbox"/> Service</p> <p>DOMEL Elektromotorji in gospodinjnski aparati d. d. Otoki 21 SLO - 64 228 Zelezniki</p> <p>Phone: +386 64/61 73 32 Fax: +386 64/64 71 50</p>	<p>Turkey <input checked="" type="checkbox"/> V/S <input checked="" type="checkbox"/> Service</p> <p>L† Mannesmann Rexroth Hidropar A..S.L† Fevzi Cakmak Cad No. 3 TR - 34630 Sefaköy Istanbul</p> <p>Phone: +90 212/541 60 70 Fax: +90 212/599 34 07</p>

Europäische Kundenbetreuungsstellen (ohne Deutschland)
European Service agencies (without Germany)

Außerhalb Europa - Outside Europe

<p>Argentina <input checked="" type="checkbox"/> V/S <input type="checkbox"/> Service</p> <p>Mannesmann Rexroth S.A.I.C. Division INDRAMAT Acassusso 48 41/7 RA - 1605 Munro (Buenos Aires)</p> <p>Phone: +54 (0)1/756 01 40 +54 (0)1/756 01 36</p>	<p>Argentina <input type="checkbox"/> V/S <input checked="" type="checkbox"/> Service</p> <p>¿ NAKASE¿ † Asesoramiento Tecnico Calle 49, No. 5764-66 RA - 1653 Villa Balester Provincia de Buenos Aires</p> <p>Phone: +54 (0) 1/768 24 13 Fax: +54 (0) 1/768 36 43</p> <p>†</p>	<p>Australia <input checked="" type="checkbox"/> V/S <input checked="" type="checkbox"/> Service</p> <p>AIMS - Australian Industrial Machinery Services Pty. Ltd. Unit 3/45 Horne ST Campbellfield 3061 AUS - Melbourne, VIC</p> <p>Phone: +61 (0)3/93 59 02 28 Fax: +61 (0)3/93 59 02 86</p> <p>†</p>	<p>Brazil <input checked="" type="checkbox"/> V/S <input checked="" type="checkbox"/> Service</p> <p>Mannesmann Rexroth Automação Ltda. Divisão INDRAMAT Rua Georg Rexroth, 609 Vila Padre Anchieta BR - 09951-270 Diadema-SP [¿ Caixa Postal 377] [BR-09901-970 Diadema-SP]¿ †</p> <p>Phone: +55 (0)11/745 90 60 +55 (0)11/745 90 70 Fax: +55 (0)11/745 90 50</p>
<p>Canada <input checked="" type="checkbox"/> V/S <input checked="" type="checkbox"/> Service</p> <p>Basic Technologies Corporation Burlington Division 3426 Mainway Drive Burlington, Ontario Canada L7M 1A8</p> <p>Phone: +1 905/335 55 11 Fax: +1 905/335-41 84</p>	<p>China <input checked="" type="checkbox"/> V/S <input type="checkbox"/> Service</p> <p>Mannesmann Rexroth (China) Ltd. Shanghai Office - Room 206 Shanghai Internat. Trade Centre 2200 Yanan Xi Lu PRC - Shanghai 200335</p> <p>Phone: +86 21/62 75 53 33 Fax: +86 21/62 75 56 66</p> <p>¿ †</p>	<p>China <input type="checkbox"/> V/S <input checked="" type="checkbox"/> Service</p> <p>Mannesmann Rexroth (China) Ltd. Shanghai Parts & Service Center 199 Wu Cao Road, Hua Cao Minhang District PRC - Shanghai 201 103</p> <p>Phone: +86 21/62 20 00 58 Fax: +86 21/62 20 00 68</p> <p>¿ †</p>	<p>China <input checked="" type="checkbox"/> V/S <input type="checkbox"/> Service</p> <p>Mannesmann Rexroth (China) Ltd. 15/F China World Trade Center 1, Jianguomenwai Avenue PRC - Beijing 100004</p> <p>Phone: +86 10/65 05 03 80 Fax: +86 10/65 05 03 79</p> <p>¿ †</p>
<p>China <input checked="" type="checkbox"/> V/S <input type="checkbox"/> Service</p> <p>Mannesmann Rexroth (China) Ltd. A-5F., 123 Lian Shan Street Sha He Kou District PRC - Dalian 116 023</p> <p>Phone: +86 411/46 78 930 Fax: +86 411/46 78 932</p>	<p>Hongkong <input checked="" type="checkbox"/> V/S <input checked="" type="checkbox"/> Service</p> <p>Rexroth (China) Ltd. 19 Cheung Shun Street 1¿st¿ Floor, Cheung Sha Wan, Kowloon, Hongkong</p> <p>Phone: +852 27/41 13 51/-54 ¿ toder/or¿ † +852 27/41 14 30 Fax: +852 27/86 07 33</p> <p>¿ †</p>	<p>India <input checked="" type="checkbox"/> V/S <input checked="" type="checkbox"/> Service</p> <p>Mannesmann Rexroth (India) Ltd. INDRAMAT Division Plot. 96, Phase III Peenya Industrial Area IND - Bangalore - 560058</p> <p>Phone: +91 (0)80/8 39 21 01 Fax: +91 (0)80/8 39 43 45</p> <p>¿</p>	<p>India <input checked="" type="checkbox"/> V/S <input checked="" type="checkbox"/> Service</p> <p>Mannesmann Rexroth (India) Ltd. INDRAMAT Division Plot. A-58, TTC Industrial Area Thane Turbhe Midc Road Mahape Village IND - Navi Mumbai - 400 701</p> <p>Phone: +91 (0)22/7 61 46 22 Fax: +91 (0)22/7 68 15 31</p>
<p>Indonesia <input checked="" type="checkbox"/> V/S <input type="checkbox"/> Service</p> <p>PT. Rexroth Wijayakusuma Jl. Raya Bekasi Km 21 Pulogadung RI - Jakarta Timur 13920</p> <p>Phone: +62 21/4 61 04 87 +62 21/4 61 04 88 Fax: +62 21/4 60 01 52</p>	<p>Japan <input checked="" type="checkbox"/> V/S <input checked="" type="checkbox"/> Service</p> <p>Rexroth Automation Co., Ltd. INDRAMAT Division 1F, I.R. Building Nakamachidai 4-26-44 Tsuzuki-ku, Yokohama-shi J - Kanagawa-ken 224-004</p> <p>Phone: +81 459/42-72 10 Fax: +81 459/42-03 41</p>	<p>Korea <input checked="" type="checkbox"/> V/S <input checked="" type="checkbox"/> Service</p> <p>¿ † Mannesmann Rexroth-Seki Co Ltd.¿ † 1500-12 Da-Dae-Dong ROK - Saha-Ku, Pusan, 604-050</p> <p>Phone: +82 (0)51/2 60 06 18 Fax: +82 (0)51/2 60 06 19</p> <p>†</p>	<p>Korea <input checked="" type="checkbox"/> V/S <input type="checkbox"/> Service</p> <p>Seo Chang Corporation Ltd. Room 903, Jeail Building 44-35 Yeouido-Dong Yeoungdeungpo-Ku C.P.O.Box 97 56 ROK - Seoul</p> <p>Phone: +82 (0)2/7 80 82 08 +82 (0)2/7 80 82 09 Fax: +82 (0)2/7 84 54 08</p>
<p>Mexico <input checked="" type="checkbox"/> V/S <input type="checkbox"/> Service</p> <p>Rexroth Mexico S.A. de C.V. Calle Neptuno 72 Unidad Ind. Vallejo MEX - 07700 Mexico, D.F.</p> <p>Phone: +52 5 754 17 11 +52 5 754 36 84 +52 5 754 12 60 Fax: +52 5 754 50 73 +52 5 752 59 43</p> <p>¿ †</p>		<p>South Africa <input checked="" type="checkbox"/> V/S <input checked="" type="checkbox"/> Service</p> <p>HYTEC Automation (Pty) Ltd. 28 Banfield Road, Industria North RSA - Maraisburg 1700</p> <p>Phone: +27 (0)11/673 20 80 Fax: +27 (0)11/673 72 69</p> <p>¿ †</p>	<p>Taiwan <input checked="" type="checkbox"/> V/S <input type="checkbox"/> Service</p> <p>Rexroth Uchida Co., Ltd. No.1, Tzu Chiang Street Tu Cheng Ind. Estate Taipei Hsien, Taiwan, R.O.C.</p> <p>Phone: +886 2/2 68 13 47 Fax: +886 2/2 68 53 88</p>

Kundenbetreuungsstellen außerhalb Europa - Service agencies outside Europe

Außerhalb Europa / USA - Outside Europe / USA

<p>USA <input type="checkbox"/> V/S <input type="checkbox"/> Service</p> <p>Mannesmann Rexroth Corporation INDRAMAT Division 5150 Prairie Stone Parkway Hoffman Estates, IL 60192-3707 Phone: +1 847/6 45 36 00 Fax: +1 847/6 45 62 01</p>	<p>USA <input type="checkbox"/> V/S <input type="checkbox"/> Service</p> <p>Mannesmann Rexroth Corporation INDRAMAT Division Central Region Technical Center USA - Auburn Hills, MI 48326 Phone: +1 248/3 93 33 30 Fax: +1 248/3 93 29 06</p>	<p>USA <input type="checkbox"/> V/S <input type="checkbox"/> Service</p> <p>Mannesmann Rexroth Corporation INDRAMAT Division Southeastern Technical Center 3625 Swiftwater Park Drive USA - Suwanee Georgia 30174 Phone: +1 770/9 32 32 00 +1 770/9 32 19 03</p>	<p>USA <input type="checkbox"/> V/S <input type="checkbox"/> Service</p> <p>Mannesmann Rexroth Corporation INDRAMAT Division Northeastern Technical Center 99 Rainbow Road USA - East Granby, Connecticut 06026 Phone: +1 860/8 44 83 77 +1 860/8 44 85 95</p>
<p>USA <input type="checkbox"/> V/S <input type="checkbox"/> Service</p> <p>Mannesmann Rexroth Corporation INDRAMAT Division Charlotte Regional Sales Office 14001 South Lakes Drive USA - Charlotte, North Carolina 28273 Phone: +1 704/5 83 97 62 +1 704/5 83 14 86</p>			

Kundenbetreuungsstellen außerhalb Europa / USA
 Service agencies outside Europe / USA

Notes

