

SPS Function Blocks for Operating a Handheld Terminal **BTC05**

Function Description

DOK-SUPPL*-BTC05***SPS-FK01-EN-P



Title	SPS Function Blocks for Operating a Handheld Terminal BTC05
Type of document	Function Description
Documentation type	DOK-SUPPL*-BTC05***SPS-FK01-EN-P
Internal filing	<ul style="list-style-type: none"> • Scope of delivery: Handheld Terminal BTC05 • Drawing no.: 120-2100-B301-01/EN
Purpose of the document	<p>This documentation provides user information about connection and parameter setting of function blocks:</p> <ul style="list-style-type: none"> • BTCBYTE, BTCWORD, BTCDWORD, BTCFLOAT, BTCSTRG, BTCUSINT, BTCINT, BTCREAL

Configuration control

Documentation identification of previous releases	Release date	Comment
109-1041-4113-01	01.98	New issue
120-2100-B301-01/EN	07.99	Changeover DOZ ⇒ DOK

Copyright © INDRAMAT GmbH, 1999

Copying this document, and giving it to others and the use or communication of the contents thereof without express authority are forbidden. Offenders are liable for the payment of damages. All rights are reserved in the event of the grant of a patent or the registration of a utility model or design (DIN 34-1).

Validity All rights are reserved with respect to the content of this documentation and the availability of the product.

Published by INDRAMAT GmbH • Bgm.-Dr.-Nebel-Str. 2 • D-97816 Lohr a. Main
Phone +49 (0)9352/40-0 • Tx 689421 • Fax +49 (0)9352/40-4885

Dept. ESM (JA)

Contents

1 Description of Function	1-1
1.1 Introduction	1-1
1.2 Installation	1-1
1.3 General Operation.....	1-2
Sending Variables to the BTC05.....	1-2
Receiving Variables from the BTC05.....	1-3
1.4 PCL.EXE Versions	1-4
1.5 Application Overview.....	1-4
1.6 Interface Overview	1-5
BTCBYTE.....	1-5
BTCWORD	1-5
BTCDWORD	1-5
BTCFLOAT	1-6
BTCSTRG	1-6
BTCUSINT	1-6
BTCINT	1-7
BTCREAL.....	1-7
1.7 System Inputs/Outputs.....	1-7
1.8 Description of Designations	1-8
1.9 Used Data Types	1-9
1.10 Description of Function Blocks BTCBYTE, BTCWORD, BTCDWORD, BTCFLOAT, BTCSTRG, BTCUSINT, BTCINT and BTCREAL	1-10
ENABLE	1-10
iAR_BYTE, iAR_WORD, iAR_DWORD, iAR_STRG, iAR_USINT, iAR_INT, iAR_REAL	1-10
VAR_NR.....	1-11
Q_VAR	1-12
I_VARIN	1-12
STATUS	1-12
SETUP	1-12
RESET	1-12
qAR_BYTE, qAR_WORD, qAR_DWORD, qAR_STRG, qAR_USINT, qAR_INT, qAR_REAL ..	1-12
I_VAROUT	1-12
ERR_FLG, ERR_NR.....	1-12
1.11 Absolute Addressing BTCFLOAT	1-13
1.12 Error Handling.....	1-14
1.13 Priorities	1-14
2 Application Example	2-15

3 List of Figures

3-1

1 Description of Function

1.1 Introduction

Indramat's SPS controls a handheld BTC05 terminal with the use of a serial interface. From the software point of view, communication between the control and the BTC05 is carried out using function block BTC05_3 (see Handheld Terminal BTC05 User's Manual).

With each telegram from or to the handheld terminal only one variable is transmitted. For that reason it must be certain, that the required variable is applied to the function block BTC05_3 or can be read at this moment (SPS cycle) within the SPS program.

Function blocks BTCBYTE, BTCWORD, BTCDWORD; BTCSTRG, BTCUSINT, BTCINT, BTCFLOAT and BTCREAL provide all functions required for the transmission of variables. One function block controls transmission and reception of 10 variables of the corresponding type. Variable requests and error messages of the BTC05_3 are monitored and evaluated. Furthermore, variables are only sent if a change in value is detected at the input. Variables received by the BTC05_3 are displayed at the output.

Note: The function blocks described are only supported in conjunction with function block BTC05_3!

1.2 Installation

The supplied floppy disk contains the programming software (SWD-BTC05*-004-16VRS-DE) and function blocks BTCBYTE, BTCWORD, BTCDWORD, BTCFLOAT, BTCSTRG, BTCUSINT, BTCINT, BTCREAL plus an SPS demonstration program (BTCDEMO2) representing functionality and application of the function blocks on the basis of an example.

The demonstration program can be installed from the floppy disk via the SPS user interface menu items 'Project' - 'Archive' - 'Project archive-Drive' - 'Get Project'. Files 'BTCDEMO2.HTT' and 'BTCDEMO2.KBD' must be loaded into the handheld terminal using the programming software (see Handheld Terminal BTC05 User's Manual, Chapter 2-10 'Project').

The function blocks are Special FBs. (It is not possible to access the function block).

- | | |
|-------------------------|---|
| PCL.EXE xx-16Vxx | The function blocks can be installed from the floppy disk via SPS user interface menu items 'Project' - 'Archive' - 'Project archive-Drive' - 'Get Special Fb/Fk/TY'. |
| PCL.EXE xx-17Vxx | The function blocks can be installed from the floppy disk via SPS user interface menu items 'Project' - 'Archive' - 'Get'. |

1.3 General Operation

In order to send or receive variables to or from the handheld terminal, they need to be programmed in advance within the message text lines using programming software 'HT 401'(see Handheld Terminal BTC05 User's Manual, page 2-5 'Programming of variables within a message text').

After programming, the message texts need to be transmitted into the handheld terminal's internal memory (see Handheld Terminal BTC05 User's Manual, page 2-10 'Project').

Sending Variables to the BTC05

The following items describe the processes and functions which run through or need to be executed when sending variables to the handheld terminal BTC05:

- The SPS calls up the message text from handheld terminal's text memory via BTC05_3 input 'WR_MSG'.
- The called message text displays the variable on the LC display. If the variable type is OUT or IN/OUT, the handheld terminal requests a variable value from the control. This request is indicated at BTC05_3's output 'Q_VAR'.
- The variable present at output 'Q_VAR' must be handed over to input 'Q_VAR' of all function blocks for sending and receiving variables used within the program. On the basis of the variable's structure elements, every function block checks whether a variable request exists and which type of variable and which variable number is requested.
- After a positive check i.e. variable type and variable number correspond to the function blocks data, the variable is accepted to the transmission stack. The variable value out of the corresponding field element (variable number) present at input 'qAR_xxxx' is sent to output 'I_VAROUT'.
- The variable sent to output 'I_VAROUT' must be handed over to input 'I_VAR' of function block BTC05_3. Function block BTC05_3 sends the variable to the handheld terminal.

Sending

Sending variables is reduced to the following two instructions if the variables are programmed and transmitted to the handheld terminal, function block BTC05_3 and the function blocks described in here are integrated within the SPS program and the system inputs and outputs are wired up correctly:

Call up message text

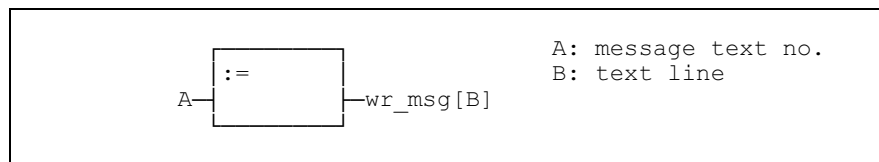

Fig. 1-1: Call up message text

Assign variable value

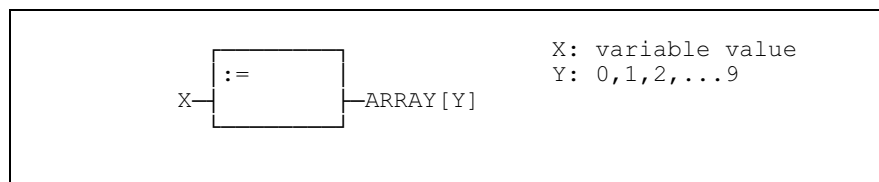

Fig. 1-2: Assign variable value

Receiving Variables from the BTC05

The following items describe the processes and functions, which run through or need to be executed when receiving variables from the handheld terminal BTC05:

- The SPS calls up the message text from handheld terminal's text memory via BTC05_3 input 'WR_MSG'.
- The called message text displays the variable on the LC display. If the variable type is IN or IN/OUT, the variable can be edited or a value can be assigned using the handheld terminal. Edit mode can be activated using function block BTC05_3's input 'EDIT_MODE'. Each modification of a variable value causes the new value to be transmitted to the control.
- Each new variable value is sent to output 'Q_VAR' by function block BTC05_3. The variable is again sent to input 'Q_VAR' of all function blocks for sending and receiving variables used within the program. On the basis of the variable's structure elements, every function block checks whether a variable is received and which type of variable and which variable number is requested.
- After a positive check i.e. variable type and variable number correspond to the function blocks data, the variable is sent to corresponding field element (variable no.) of output 'qAR_xxxx'.

Receiving

The variables are sent to the individual field elements of output 'qAR_xxxx' according to the variable numbers, if they are programmed within the handheld terminal and the function blocks are wired up correctly. Within the SPS program, the user can handle the field elements as if they were standard variables.

1.4 PCL.EXE Versions

The following function blocks are used within the PLC.EXE versions:

PCL.EXE xx-16Vxx BTCBYTE, BTCWORD, BTCDWORD; BTCSTRG, BTCUSINT, BTCINT and **BTCFLOAT**

PCL.EXE xx-17Vxx BTCBYTE, BTCWORD, BTCDWORD; BTCSTRG, BTCUSINT, BTCINT and **BTCREAL**

1.5 Application Overview

Function block	Application
BTCBYTE	Sends/receives 1-Byte coded UINT and SINT variables to/from BTC05_3
BTCWORD	Sends/receives 2-Byte coded INT and UINT variables to/from BTC05_3
BTCDWORD	Sends/receives 4-Byte coded DINT and UDINT variables to/from BTC05_3
BTCFLOAT	Sends/receives 4-Byte coded FLOAT variables (REAL) to/from BTC05_3
BTCSTRG	Sends/receives STRING variables to/from BTC05_3 (20 characters max.)
BTCUSINT	Sends/receives USINT variables to/from BTC05_3
BTCINT	Sends/receives INT variables to/from BTC05_3
BTCREAL (PCL.EXE xx-17Vxx)	Sends/receives REAL variables to/from BTC05_3

Fig. 1-3: Application overview

1.6 Interface Overview

BTCBYTE

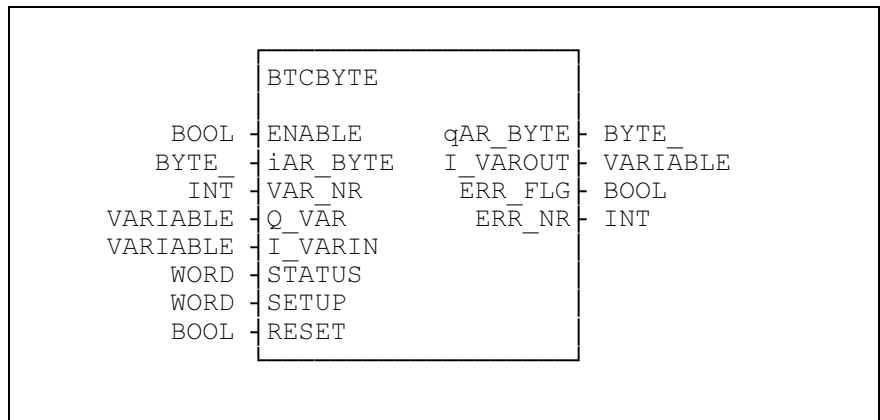

Fig. 1-4: BTCBYTE

BTCWORD

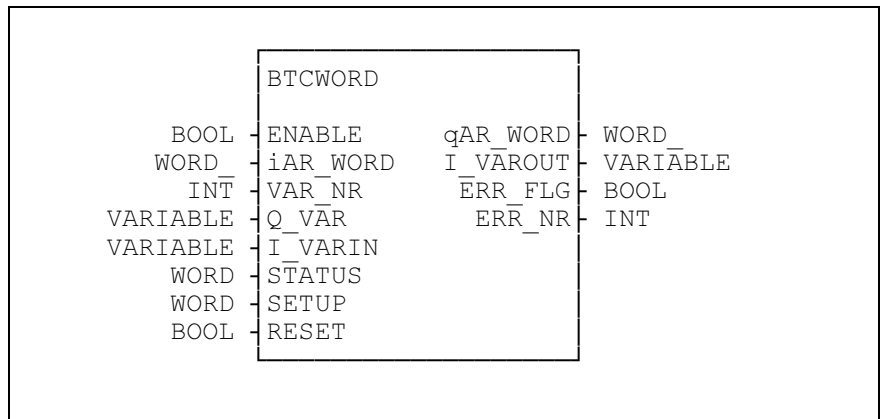

Fig. 1-5: BTCWORD

BTCDWORD

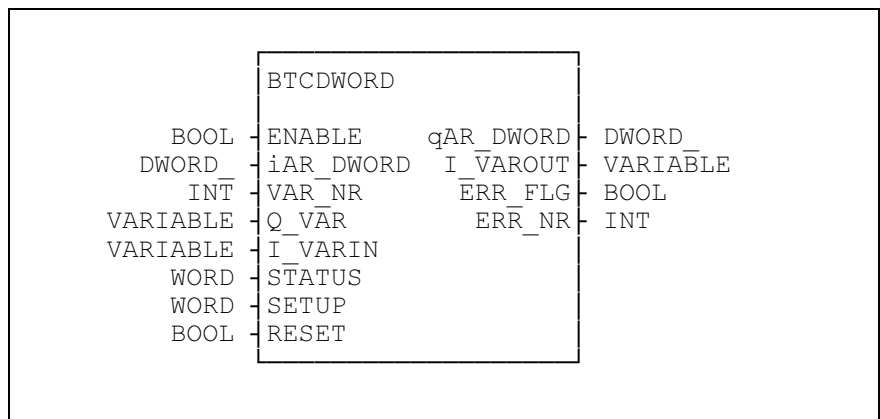

Fig. 1-6: BTCDWORD

BTCFLOAT

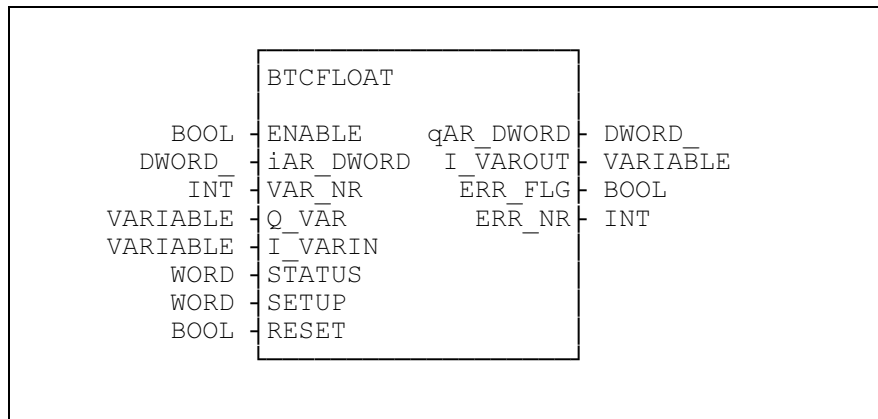

Fig. 1-7: BTCFLOAT

BTCSTRG

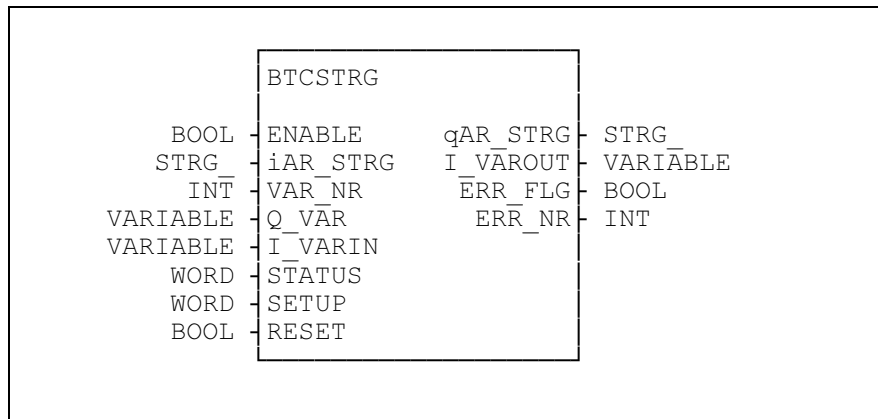

Fig. 1-8: BTCSTRG

BTCUSINT

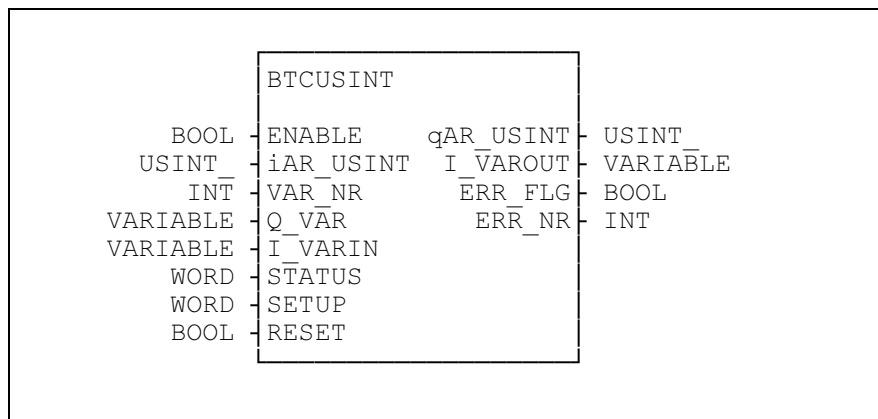

Fig. 1-9: BTCUSINT

BTCINT

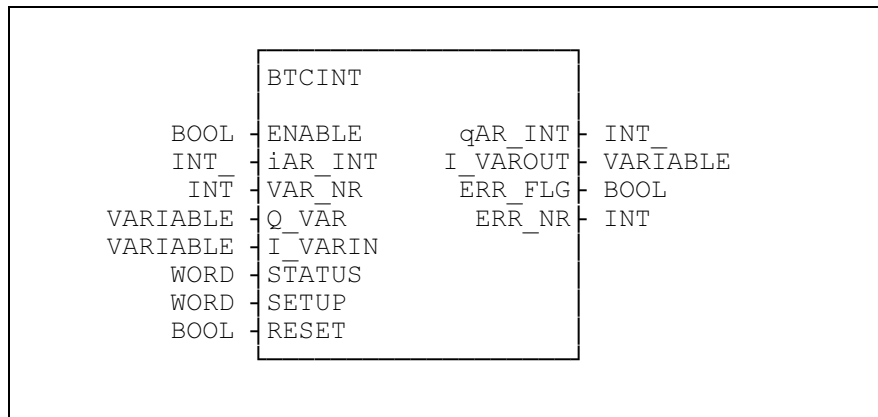

Fig. 1-10: BTCINT

BTCREAL

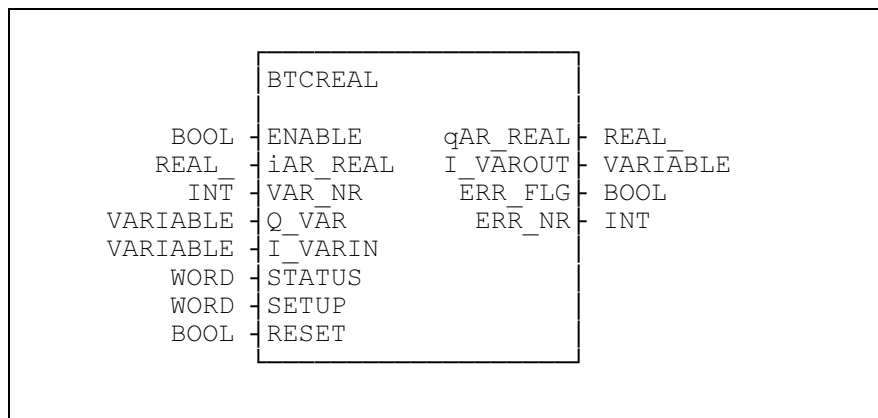

Fig. 1-11: BTCREAL

1.7 System Inputs/Outputs

The following inputs and outputs exclusively serves communication with function block BTC05_3:

- System inputs**
 - Q_VAR
 - I_VARIN
 - STATUS
 - SETUP
- System outputs**
 - I_VAROUT

Note: Gateway signals Q_VAR, I_VARIN, STATUS, SETUP and I_VAROUT exclusively serves communication with function block BTC05_3 and must not be influenced by the program.

Note: It is recommended that either all variables are sent to the handheld terminal using the function blocks described or none. Influencing gateway signals I_VAR and Q_VAR at function block BTC05_3 by program, will cause a fault in transmission flow of the variable for sure.

1.8 Description of Designations

Designation	Application	Type
Input variables		
ENABLE	Enable input	BOOL
iAR_BYTE (BTCBYTE)	ARRAY[0..9], 1-Byte variable values (SINT, USINT)	BYTE_
iAR_WORD (BTCWORD)	ARRAY[0..9], 2-Byte variable values (INT, UDINT)	WORD_
iAR_DWORD (BTCDWORD), (BTCFLOAT)	ARRAY[0..9], 4-Byte variable values (UINT32, SINT32), (REAL)	DWORD_
iAR_STRG (BTCSTRG)	ARRAY[0..9], STRING variables (20 characters max.)	STRING_
iAR_USINT (BTCUSINT)	ARRAY[0..9], USINT variables	USINT_
iAR_INT (BTCINT)	ARRAY[0..9], INT variables	INT_
iAR_REAL (BTCREAL)	ARRAY[0..9], REAL variables	REAL_
VAR_NR	Start number of variable	INT
Q_VAR	Variable received by BTC05_3	VARIABLE
I_VARIN	Variable sent to BTC05_3	VARIABLE
STATUS	Communication status handheld terminal	WORD
SETUP	Initial setting handheld terminal	WORD
RESET	Error confirmation	BOOL
Output variables		
qAR_BYTE (BTCBYTE)	ARRAY[0..9], 1-Byte variable values (SINT, USINT)	BYTE_
qAR_WORD (BTCWORD)	ARRAY[0..9], 2-Byte variable values (INT, UDINT)	WORD_
qAR_DWORD (BTCDWORD), (BTCFLOAT)	ARRAY[0..9], 4-Byte variable values (UINT32, SINT32), (REAL)	DWORD_
qAR_STRG (BTCSTRG)	ARRAY[0..9], STRING variables (20 characters max.)	STRING_
qAR_USINT (BTCUSINT)	ARRAY[0..9], USINT variables	USINT_
qAR_INT (BTCINT)	ARRAY[0..9], INT variables	INT_
qAR_REAL (BTCREAL)	ARRAY[0..9], REAL variables	REAL_
I_VAROUT	Sending variable to BTC05_3	VARIABLE
ERR_FLG	Error flag	BOOL
ERR_NR	Error description	INT

Fig. 1-12: Description of Designations

1.9 Used Data Types

Data type	Application	Type
BYTE_	1-Byte coded variable values send/receive (SINT, USINT)	ARRAY [0...9] of BYTE
WORD_	2-Byte coded variable values send/receive (INT, UINT)	ARRAY [0...9] of WORD
DWORD_	4-Byte coded variable values send/receive (DINT, UDINT), (REAL)	ARRAY [0...9] of DWORD
STRING_	STRING variables send/receive (20 characters max.)	ARRAY [0...9] of STRING[20]
USINT_	USINT variables send/receive	ARRAY [0...9] of USINT
INT_	INT variables send/receive	ARRAY [0...9] of INT
REAL_	REAL variables send/receive	ARRAY [0...9] of REAL
VARIABLE	Variable number Type of variable Variable request 1-Byte variable value 2-Byte variable value 4-Byte variable value STRING variable	STRUCT VAR INT TYP INT REQUEST BOOL BYTE_ BYTE WORD_ WORD DWORD_ DWORD STRING_ STRING[20] END_STRUCT

Fig. 1-13: Used data types

1.10 Description of Function Blocks BTCBYTE, BTCWORD, BTCDWORD, BTCFLOAT, BTCSTRG, BTCUSINT, BTCINT and BTCREAL

ENABLE

Input 'ENABLE' represents the enable input. Incoming variable requests and variable error messages are processed within the internal stack if this input becomes a logical one.

No variables are sent to or received from the handheld terminal if the enable input is logical zero.

Note: The input must at become a logical one no later than the same SPS cycle in which a variable request is active or a variable is received by the handheld terminal.

iAR_BYTE, iAR_WORD, iAR_DWORD, iAR_STRG, iAR_USINT, iAR_INT, iAR_REAL

A single function block can at the most process 10 variables of the same type and send or receive to/from the handheld terminal. The data type to be used at this input can be obtained from chapter 1.8 'Description of Designations'. A second function block needs to be applied, if more than 10 variables of the same type are used.

When using function blocks BTCBYTE, BTCWORD, BTCDWORD and BTCFLOAT, variables must be converted into 1, 2, or 4 byte coded words prior to transmission. Functions for type conversion are provided by the Indramat SPS program.

Note: PCL.EXE xx-16Vxx does not contain a function to convert a REAL number into a DWORD and vice versa . Type conversion must be carried out via absolutely addressed variables. (see chapter 1.11 'Absolute Addressing BTCFLOAT').

Without prior conversion, variables can be directly applied to the inputs 'iAR_STRG', 'iAR_USINT', 'iAR_INT' and 'iAR_REAL' of function blocks BTCSTRG; BTCUSINT, BTCINT and BTCREAL.

The variable applied to input 'iAR_xxxx' is transmitted to the handheld terminal as soon as function block BTC05_3 indicates a variable request. Transmission also results when a change of value is detected at input 'iAR_xxxx'.

If the variable to be sent is no longer displayed on the handheld terminal, it is deleted from the function block's internal transmission list and the variable value applied to input 'iAR_xxxx' is ignored.

VAR_NR

This input determines the variable numbers to be monitored by the respective function block (send/receive).

Note: When programming the handheld terminal, variables should be set up in a way that variable numbers of the same type are listed subsequently. Variables of the same type should be piled up in blocks of ten.

Example An example for assigning variable numbers and the elements of array 'strg_100' to function block BTCSTRG is shown in the table below.

VAR_NR: 100	iAR_STRG: strg_100
100	strg_100[0]
101	strg_100[1]
...	...
109	strg_100[9]

Fig. 1-14: Example - Variable number and field element assignment

The value applied to input 'VAR_NR' always corresponds to field element [0] of input 'iAR_xxxx'.

The function block monitors variable numbers 100 to 109 of STRING type, if value 100 is applied to input 'VAR_NR'. The relevant variable out of array 'strg_100' applied to input 'iAR_STRG' is sent to the handheld terminal after a variable request. In accordance to that, variables received by the handheld terminal are output in array 'strg_100' of output 'qAR_STRG'.

Value range 100 ... 32758 is admissible for function blocks BTCBYTE, BTCWORD, BTCDWORD, BTCFLOAT, BTCUSINT, BTCINT and BTCREAL. Function block BTCSTRG admits value range 100 ... 246 at input 'VAR_NR'.

Note: When using several function blocks of the same kind, care must be taken that the ranges of variable numbers do not intersect!

The function blocks listed in the table below send and receive the same type of variable:

Function block	Type of variable
BTCBYTE BTCUSINT	1-Byte coded variable values
BTCWORD BTCINT	2-Byte coded variable values

Fig. 1-15: Function blocks of equal type

Q_VAR

The variable applied to output 'Q_VAR' of function block BTC05_3 must be applied to input 'Q_VAR' (system input).

I_VARIN

Input 'I_VARIN' corresponds to input 'I_VAR' of function block BTC05_3. The same variable must be applied to both inputs (system input).

STATUS

The STATUS output word of BTC05_3 must also be handed over to the function block (system input).

SETUP

Certain basic settings are checked by the SETUP word at function block BTC05_3. Therefore the same word must be applied to this input (system input).

Bit 10 and 11 are checked (see also page 4-7 of Handheld Terminal's Users Manual).

Note: No variables can be sent to the handheld terminal if bits 10 and 11 are not logical 1. In this case an error is indicated at output 'ERR_FLG' and described by output 'ERR_NR'.

RESET

Each existing error must be acknowledged by the 'RESET' input (logical 1). When acknowledging, the internal stack is cleared and variables can be sent after a repeated request.

**qAR_BYTE, qAR_WORD, qAR_DWORD, qAR_STRG, qAR_USINT,
qAR_INT, qAR_REAL**

The variable applied to input 'iAR_xxxx' is also applied to output 'qAR_xxxx'. Variables sent to or received from the BTC05 must always be written to or read from this variable (ARRAY).

I_VAROUT

Output 'I_VAROUT' must be handed over to BTC05 input 'I_VAR' (system output).

Note: The same variable must be applied to input 'I_VARIN', output 'I_VAROUT' and BTC05_3 input 'I_VAR'!

ERR_FLG, ERR_NR

Output 'ERR_FLG' indicates an existing error. An error must be acknowledged by the 'RESET' input. The error is described by output 'ERR_NR'.

1.11 Absolute Addressing BTCFLOAT

Function block BTCFLOAT has been developed especially for the PCL.EXE xx-16Vxx. Because this version does not provide a function to convert a REAL into DWORD, the conversion must be carried out via absolute addressing of the variables.

Example Within the declaration, the following variables are addressed absolutely (see also application example 'BTCDEMO2'):

Designation	AT	TYPE
dword_100	%MW5	DWORD_
real_100	%MW5	REAL_

Fig. 1-16: Absolute addressing of variables

Within the SPS program, the user can assign and read out REAL numbers to and from ARRAY 'real_100'. The individual field elements can be treated like ordinary REAL variables.

On the other hand, ARRAY 'dword_100' is applied to input 'iAR_DWORD' and output 'qAR_DWORD' of function block BTCFLOAT. Because both variables access the same address area (%MW5), the bit pattern is interpreted as REAL number (real_100) one time and as DWORD (dword_100) the other time.

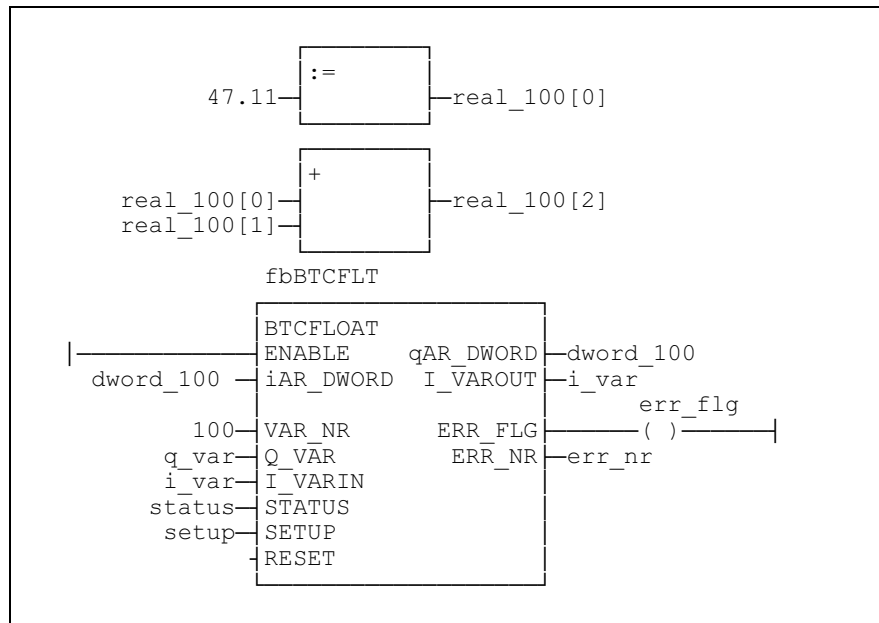

Fig. 1-17: Using absolutely addressed variables

1.12 Error Handling

ERR_NR	Description	Error location
0	No error detected	
1	Handheld terminal's variable error message is not displayed	Bit 10 of SETUP word not set (BTC05_3)
2	Handheld terminal's variable error message is not displayed	Bit 11 of SETUP word not set (BTC05_3)
3	Variable number out of admissible range of 100 ... 32758	Input VAR_NR (BTCINT8, BTCINT16, BTCINT32, BTCREAL)
4	Variable number out of admissible range of 0...246	Input VAR_NR (BTCSTRG)

Fig. 1-18: Error handling

1.13 Priorities

If several function blocks are used in a single program, each function block holds equal priority. A function block sends a variable, if a request exists or a change in value was detected at the relevant input. After successful transmission of a variable, the program's subsequent function block is executed.

2 Application Example

The following example demonstrates the application of function blocks BTCSTRG, BTCFLT and BTCINT in conjunction with function block BTC05_3.

The example illustrates how, in a simple way, variable values can be sent and received to and from the handheld terminal. Doing this, correct wiring of the function blocks system inputs and outputs (BTCSTRG, BTCFLT, BTCINT ('Q_VAR', 'I_VARIN', 'STATUS', 'SETUP', 'I_VAROUT') and BTC05_3 ('I_VAR', 'SETUP', 'STATUS', 'Q_VAR')) is decisive. Within the SPS program, the individual field elements of inputs 'iAR_xxxx' or outputs 'qAR_xxxx' can be treated as standard variables. Assigned variables are automatically transmitted to the handheld terminal provided that the variable is displayed on the LC-display. Variable values received from the control are instantly available within the field elements.

Three different menu screens are displayed within the handheld terminals LC-display. The menu screens are generated out of the handheld terminals internal memory by the message text call. The message texts ('BTCDEMO2.HTT', 'BTCDEMO2.KBD') must be loaded as described in chapter 'Project' (page 2-10) of Handheld Terminal's Users manual. The files are located in the directory of the programming software.

The following 4 messages appear within the 1st menu:

1st line: INDRAMAT

2nd line: Bgm.-Dr.-Nebel-Str.2

3rd line: 97816 Lohr am Main

4th line: DEMO REAL DEMO INT

These four messages have been programmed using string variables. The control calls the four message texts out of the text memory via message number. The message texts contain a string variable of 20 characters each. The string variables are written by the program after the message texts have been called.

The 2nd menu screen is displayed when calling menu item 'DEMO REAL'.

1st line: REAL DEMO

2nd line: $0.0 + 0.0 = 0.0$, 3

3rd line: $0.0 - 0.0 = 0.0$

4th line: EDIT ESC

Lines 1 and 4 have been programmed via STRING variable. Message texts of line 2 and 3 contain 3 FLOAT variables each. The variables can be modified using menu item 'EDIT'. After data input, the sum or the difference is calculated within the SPS program. The result is sent back to the handheld terminal. Menu item 'ESC' leads back to the 1st menu.

Menu item 'DEMO INT' proceeds to the 3rd menu screen.

1st line: INTEGER DEMO

2nd line: $0 + 0 = 0$, 3

3rd line: $0 - 0 = 0$, 4

4th line: EDIT ESC

Message texts of line 2 and 3 contain three integer variables each. The menu itself is the same as menu 'DEMO REAL'.

Prior to starting the program, interface data (DEVICE, SERNR and BAUD) set to function block BTC05_3 need to be checked.

The application example is stored as project archive 'BTCDEMO02' on the floppy disk provided.

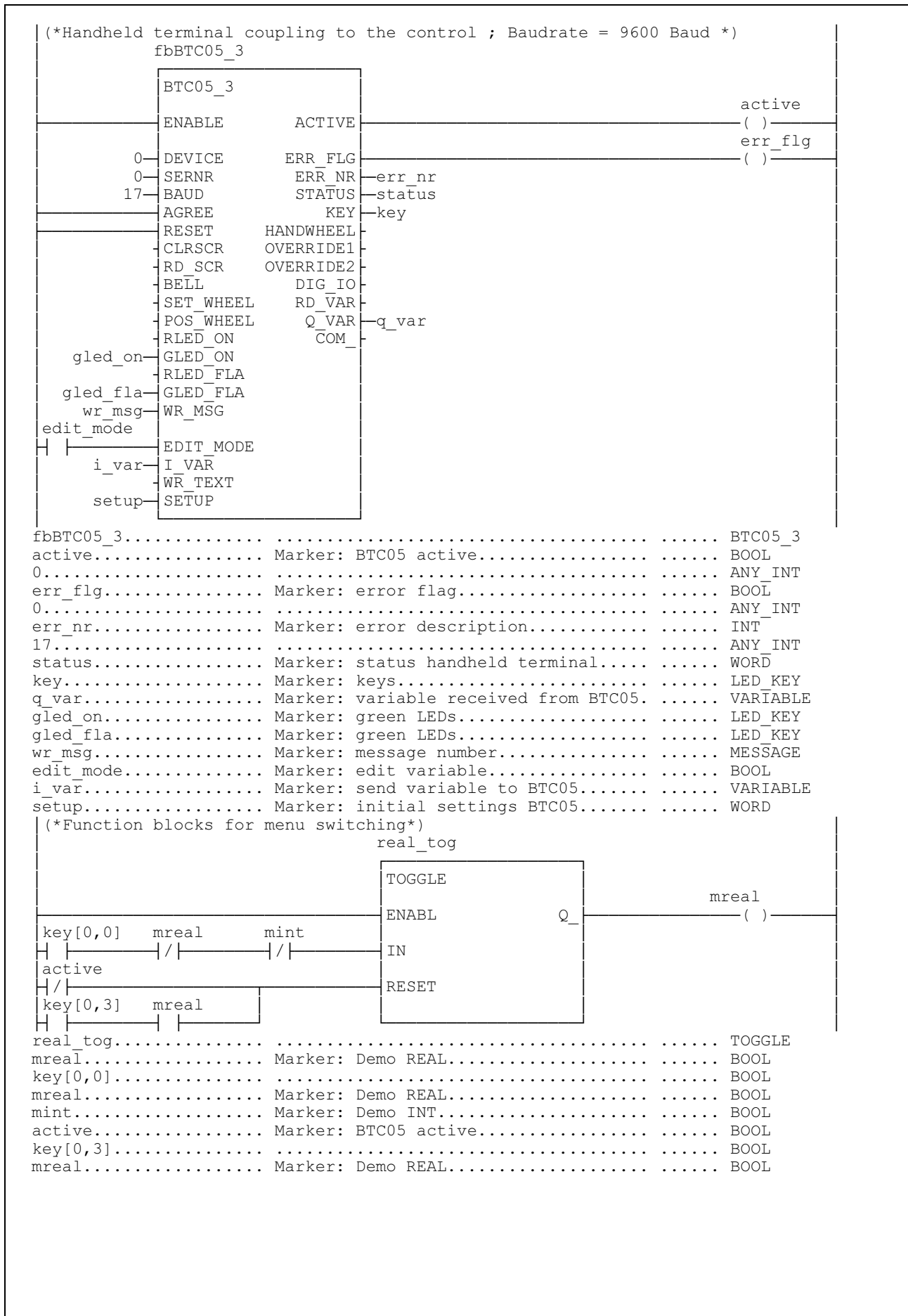

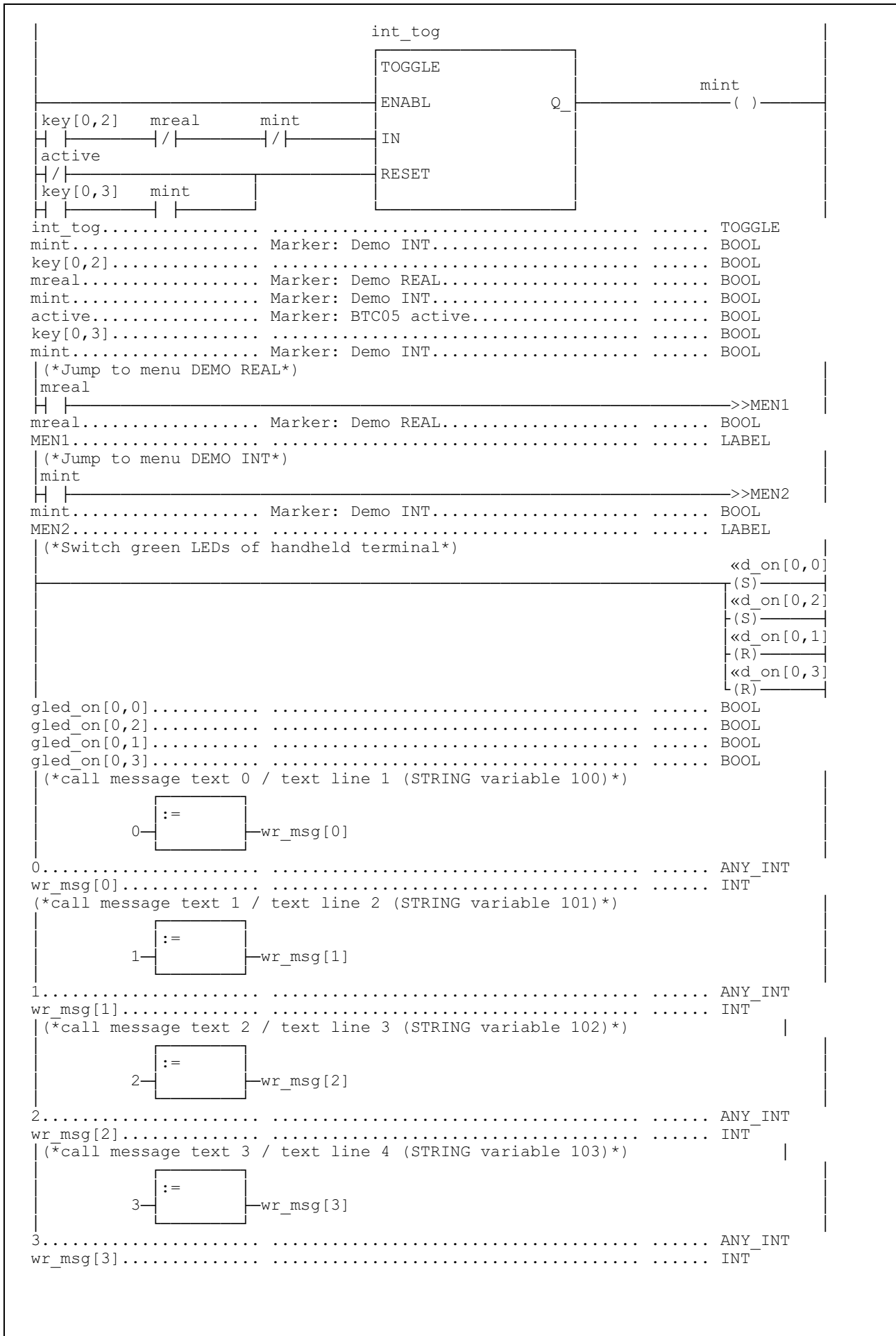

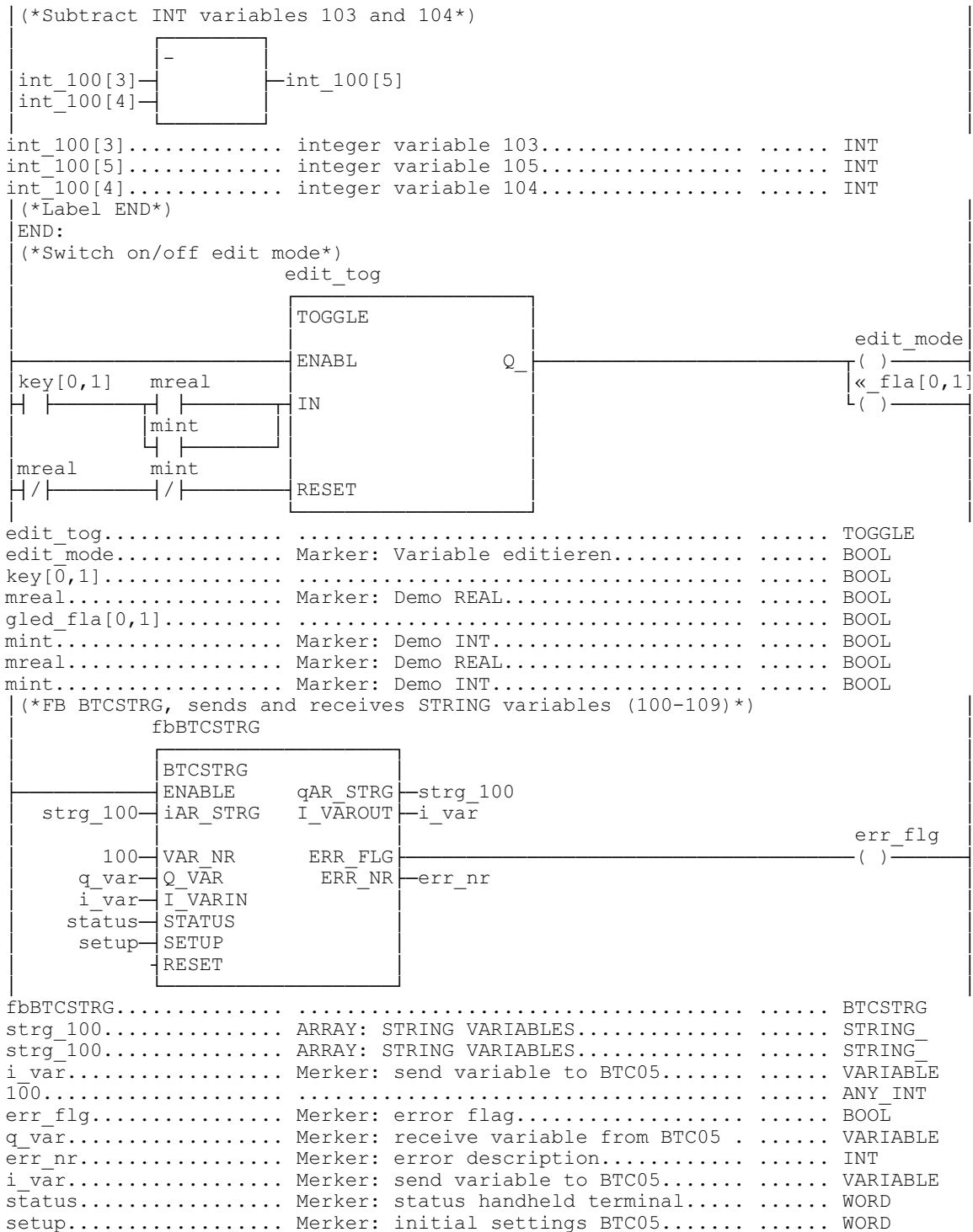

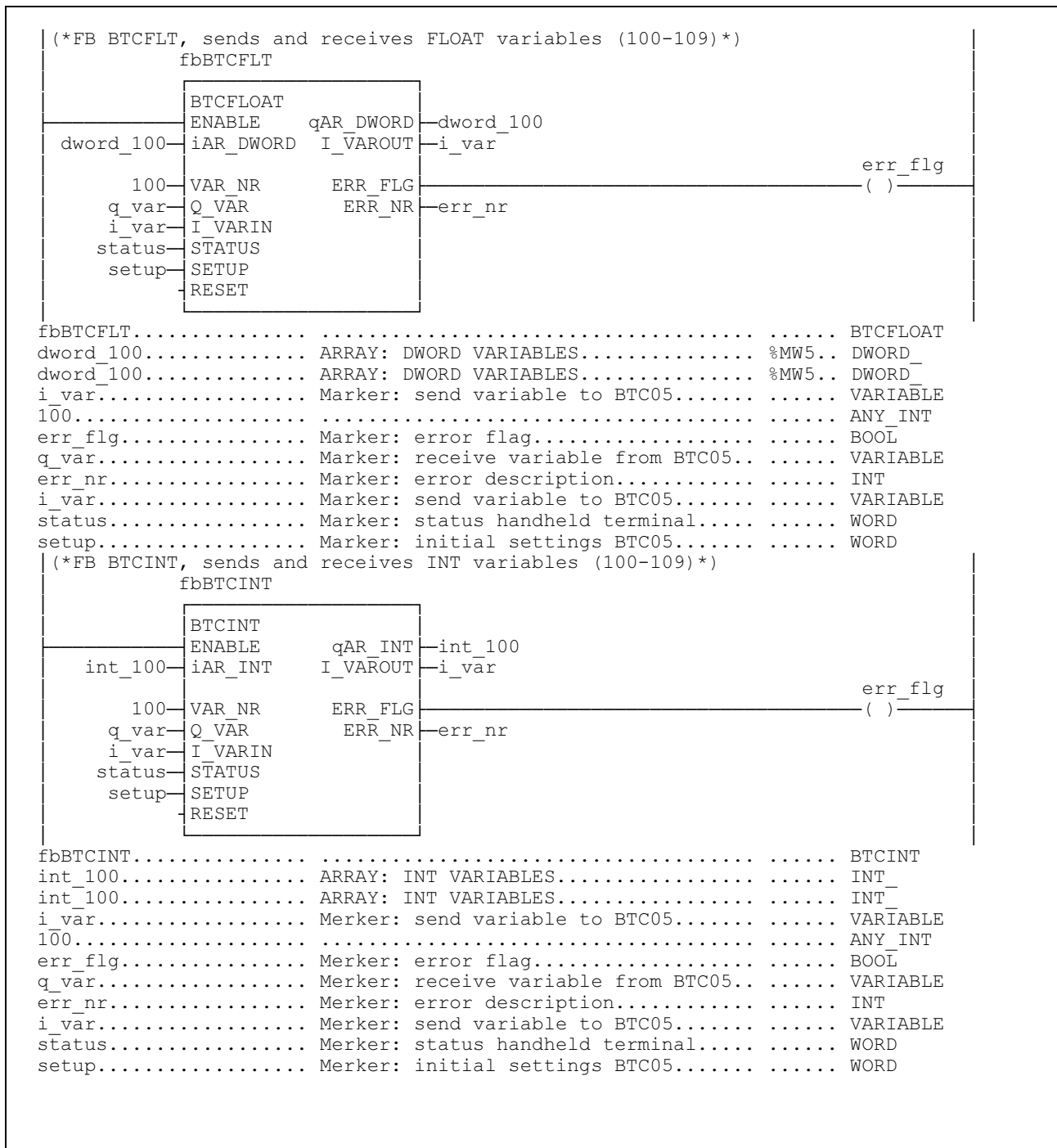

3 List of Figures

Fig. 1-1: Call up message text.....	1-2
Fig. 1-2: Assign variable value.....	1-2
Fig. 1-3: Application overview.....	1-4
Fig. 1-4: BTCBYTE	1-5
Fig. 1-5: BTCWORD	1-5
Fig. 1-6: BTCDWORD	1-5
Fig. 1-7: BTCFLOAT	1-6
Fig. 1-8: BTCSTRG	1-6
Fig. 1-9: BTCUSINT	1-6
Fig. 1-10: BTCINT	1-7
Fig. 1-11: BTCREAL.....	1-7
Fig. 1-12: Description of Designations.....	1-8
Fig. 1-13: Used data types.....	1-9
Fig. 1-14: Example - Variable number and field element assignment..	1-11
Fig. 1-15: Function blocks of equal type.....	1-11
Fig. 1-16: Absolute addressing of variables.....	1-13
Fig. 1-17: Using absolutely addressed variables.....	1-13
Fig. 1-18: Error handling.....	1-14

Kundenbetreuungsstellen - Sales & Service Facilities

Deutschland – Germany

vom Ausland:
from abroad:

(0) nach Landeskennziffer weglassen!!
don't dial (0) after country code!

Vertriebsgebiet Mitte Germany Centre <input checked="" type="checkbox"/> SALES <input checked="" type="checkbox"/> Service INDRAMAT GmbH Bgm.-Dr.-Nebel-Str. 2 D - 97816 Lohr am Main Telefon: +49 (0)9352/40-0 Telefax: +49 (0)9352/40-4885	Vertriebsgebiet Ost Germany East <input checked="" type="checkbox"/> SALES <input checked="" type="checkbox"/> Service INDRAMAT GmbH Beckerstraße 31 D - 09120 Chemnitz Telefon: +49 (0)371/35 55-0 Telefax: +49 (0)371/35 55-333	Vertriebsgebiet West Germany West <input checked="" type="checkbox"/> SALES <input checked="" type="checkbox"/> Service Mannesmann Rexroth AG Vertrieb Deutschland Regionalzentrum West Borsigstrasse 15 D - 40880 Ratingen Telefon: +49 (0)2102/409-0 Telefax: +49 (0)2102/409-406	Vertriebsgebiet Nord Germany North <input checked="" type="checkbox"/> SALES <input type="checkbox"/> Service INDRAMAT GmbH Kieler Straße 212 D - 22525 Hamburg Telefon: +49 (0)40/85 31 57-0 Telefax: +49 (0)40/85 31 57-15
Vertriebsgebiet Süd Germany South <input checked="" type="checkbox"/> SALES <input type="checkbox"/> Service INDRAMAT GmbH Ridlerstraße 75 D-80339 München Telefon: +49 (0)89/540138-30 Telefax: +49 (0)89/540138-10 indramat.mue@t-online.de	Gebiet Südwest Germany South-West <input checked="" type="checkbox"/> SALES <input checked="" type="checkbox"/> Service INDRAMAT GmbH Böblinger Straße 25 D-71229 Leonberg Telefon: +49 (0)7152/9 72-6 Telefax: +49 (0)7152/9 72-727	Vertriebsgebiet Mitte Germany Centre <input checked="" type="checkbox"/> SALES <input type="checkbox"/> Service Mannesmann Rexroth AG Geschäftsbereich INDRAMAT Lilistraße 14-18 D – 63067 Offenbach Telefon: +49 (0) 62/82 00 90-0 Telefax: +49 (0) 62/82 00 90-80	Vertriebsgebiet Nord Germany North <input checked="" type="checkbox"/> SALES <input type="checkbox"/> Service Mannesmann Rexroth AG Vertriebsniederlassung Region Nord Geschäftsbereich INDRAMAT Schützenstraße 20 D – 30853 Langenhagen Telefon: +49 (0) 511/72 66 57-0 Telefax: +49 (0) 511/72 66 57-93
			INDRAMAT Service-Hotline INDRAMAT GmbH Telefon: +49 (0)172/660 04 06 oder/or Telefon: +49 (0)171/333 88 26 Hotline ERSATZTEILE: - nur an Werktagen von 15 -18 Uhr - +49 (0) 93 52/40 42 22

Kundenbetreuungsstellen in Deutschland - Service agencies in Germany

Europa – Europe

vom Ausland: (0) nach Landeskennziffer weglassen, 0 nach Landeskennziffer mitwählen!
from abroad: don't dial (0) after country code, dial 0 after country code!

<p>Austria <input checked="" type="checkbox"/> SALES <input type="checkbox"/> Service</p> <p>Mannesmann Rexroth Ges.m.b.H. Geschäftsbereich INDRAMAT Hägelingasse 3 A - 1140 Wien</p> <p>Telefon: +43 (0)1/9852540-400 Telefax: +43 (0)1/9852540-93</p>	<p>Austria <input checked="" type="checkbox"/> SALES <input type="checkbox"/> Service</p> <p>Mannesmann Rexroth G.m.b.H. Geschäftsbereich INDRAMAT Industriepark 18 A - 4061 Pasching</p> <p>Telefon: +43 (0)7221/605-0 Telefax: +43 (0)7221/605-21</p>	<p>Belgium <input checked="" type="checkbox"/> SALES <input checked="" type="checkbox"/> Service</p> <p>Mannesmann Rexroth N.V.-S.A. Geschäftsbereich INDRAMAT Industrielaan 8 B-1740 Ternat</p> <p>Telefon: +32 (0)2/5830719 Telefax: +32 (0)2/5830731</p>	<p>Denmark <input checked="" type="checkbox"/> SALES <input checked="" type="checkbox"/> Service</p> <p>BEC AS Zinkvej 6 DK-8900 Randers</p> <p>Telefon: +45 (0)87/11 90 60 Telefax: +45 (0)87/11 90 61</p>
<p>England <input checked="" type="checkbox"/> SALES <input checked="" type="checkbox"/> Service</p> <p>Mannesmann Rexroth Ltd. INDRAMAT Division Broadway Lane, South Cerney GB - Cirencester, Glos GL7 5UH</p> <p>Telefon: +44 (0)1285/863000 Telefax: +44 (0)1285/863030</p>	<p>Finland <input checked="" type="checkbox"/> SALES <input type="checkbox"/> Service</p> <p>Rexroth Mecman Oy INDRAMAT division Ansatie 6 SF-017 40 Vantaa</p> <p>Telefon: +358 (0)9/84 91-11 Telefax: +358 (0)9/84 91-13 60</p>	<p>France <input checked="" type="checkbox"/> SALES <input checked="" type="checkbox"/> Service</p> <p>Mannesmann Rexroth S.A. Division INDRAMAT Parc des Barbanniers 4, Place du Village F-92632 Gennevilliers Cedex</p> <p>Telefon: +33 (0)141 47 54 30 Telefax: +33 (0)147 94 69 41 Hotline: +33 (0)6 08 33 43 28</p>	<p>France <input checked="" type="checkbox"/> SALES <input type="checkbox"/> Service</p> <p>Mannesmann Rexroth S.A. Division INDRAMAT 270, Avenue de Lardenne F - 31100 Toulouse</p> <p>Telefon: +33 (0)5 61 49 95 19 Telefax: +33 (0)5 61 31 00 41</p>
<p>France <input checked="" type="checkbox"/> SALES <input type="checkbox"/> Service</p> <p>Mannesmann Rexroth S.A. Division INDRAMAT 91, Bd. Irène Joliot-Curie F - 69634 Vénissieux – Cedex</p> <p>Telefon: +33 (0)4 78 78 53 65 Telefax: +33 (0)4 78 78 52 53</p>	<p>Italy <input checked="" type="checkbox"/> SALES <input checked="" type="checkbox"/> Service</p> <p>Mannesmann Rexroth S.p.A. Divisione INDRAMAT Via G. Di Vittoria, 1 I - 20063 Cernusco S/N.MI</p> <p>Telefon: +39 02/92 36 52 70 Telefax: +39 02/92 36 55 12</p>	<p>Italy <input checked="" type="checkbox"/> SALES <input checked="" type="checkbox"/> Service</p> <p>Mannesmann Rexroth S.p.A. Divisione INDRAMAT Via Borgomanero, 11 I - 10145 Torino</p> <p>Telefon: +39 011/7 50 38 11 Telefax: +39 011/7 71 01 90</p>	<p>Italy <input checked="" type="checkbox"/> SALES <input type="checkbox"/> Service</p> <p>Mannesmann Rexroth S.p.A. Divisione INDRAMAT Via del Progresso, 16 (Zona Ind.) I - 35020 Padova</p> <p>Telefon: +39 049/8 70 13 70 Telefax: +39 049/8 70 13 77</p>
<p>Italy <input type="checkbox"/> SALES <input checked="" type="checkbox"/> Service</p> <p>Mannesmann Rexroth S.p.A. Divisione Rexroth Indramat Via Mascia, 1 I - 80053 Castellammare di Stabia NA</p> <p>Telefon: +39 081/8 71 57 00 Telefax: +39 081/8 71 68 86</p>	<p>Italy <input checked="" type="checkbox"/> SALES <input type="checkbox"/> Service</p> <p>Mannesmann Rexroth S.p.A. Divisione INDRAMAT Viale Oriani, 38/A I - 40137 Bologna</p> <p>Telefon: +39 051/34 14 14 Telefax: +39 051/34 14 22</p>	<p>Netherlands <input checked="" type="checkbox"/> SALES <input type="checkbox"/> Service</p> <p>Hydraudyne Hydrauliek B.V. Kruisbroeksestraat 1 (P.O. Box 32) NL - 5281 RV Boxtel</p> <p>Telefon: +31 (0)411/65 19 51 Telefax: +31 (0)411/65 14 83 e-mail: indramat@hydraudyne.nl</p>	<p>Netherlands <input type="checkbox"/> SALES <input checked="" type="checkbox"/> Service</p> <p>Hydrocare B.V. Kruisbroeksestraat 1 (P.O. Box 32) NL - 5281 RV Boxtel</p> <p>Telefon: +31 (0)411/65 19 51 Telefax: +31 (0)411/67 78 14</p>
<p>Norway <input checked="" type="checkbox"/> SALES <input type="checkbox"/> Service</p> <p>Rexroth Mecman AS INDRAMAT Division Berghagan 1 or Box 3007 N-1405 Ski-Langhus N-1402 Ski</p> <p>Telefon: +47 (0)64 86 41 00 Telefax: +47 (0)64 86 90 62</p>	<p>Poland <input checked="" type="checkbox"/> SALES <input type="checkbox"/> Service</p> <p>Mannesmann Rexroth Sp.zo.o. Biuro Poznan ul. Dabrowskiego 81/85 PL – 60-529 Poznan</p> <p>Telefon: +48 061/847 67 99 Telefax: +48 061/847 64 02</p>	<p>Russia <input type="checkbox"/> SALES <input checked="" type="checkbox"/> Service</p> <p>Tschudnenko E.B. Arsenia 22 RUS - 153000 Ivanovo Rußland</p> <p>Telefon: +7 093/223 96 33 oder/or +7 093/223 95 48 Telefax: +7 093/223 46 01</p>	<p>Spain <input checked="" type="checkbox"/> SALES <input checked="" type="checkbox"/> Service</p> <p>Mannesmann Rexroth S.A. Division INDRAMAT Centro Industrial Santiga Obradors s/n E-08130 Santa Perpetua de Mogoda Barcelona</p> <p>Telefon: +34 937 47 94 00 Telefax: +34 937 47 94 01</p>
<p>Spain <input checked="" type="checkbox"/> SALES <input checked="" type="checkbox"/> Service</p> <p>Goimendi S.A. División Indramat Jolastokieta (Herrera) Apartado 11 37 E - 20017 San Sebastian</p> <p>Telefon: +34 9 43/40 01 63 Telefax: +34 9 43/39 17 99</p>	<p>Sweden <input checked="" type="checkbox"/> SALES <input checked="" type="checkbox"/> Service</p> <p>Rexroth Mecman Svenska AB INDRAMAT Division Varuvägen 7 S - 125 81 Stockholm</p> <p>Telefon: +46 (0)8/727 92 00 Telefax: +46 (0)8/647 32 77</p>	<p>Slowenia <input checked="" type="checkbox"/> SALES <input checked="" type="checkbox"/> Service</p> <p>INDRAMAT elektromotorji d.o.o. Otoki 21 SLO - 64 228 Zelezniki</p> <p>Telefon: +386 64/61 73 32 Telefax: +386 64/64 71 50</p>	<p>Turkey <input checked="" type="checkbox"/> SALES <input checked="" type="checkbox"/> Service</p> <p>Mannesmann Rexroth Hidropar A.S. Fevzi Cakmak Cad No. 3 TR - 34630 Sefaköy Istanbul</p> <p>Telefon: +90 212/541 60 70 Telefax: +90 212/599 34 07</p>
<p>Switzerland <input checked="" type="checkbox"/> SALES <input checked="" type="checkbox"/> Service</p> <p>-East-</p> <p>Mannesmann Rexroth Schweiz AG Geschäftsbereich INDRAMAT Gewerbstraße 3 CH-8500 Frauenfeld</p> <p>Telefon: +41 (0)52/720 21 00 Telefax: +41 (0)52/720 21 11</p>	<p>Switzerland <input checked="" type="checkbox"/> SALES <input type="checkbox"/> Service</p> <p>-West-</p> <p>Mannesmann Rexroth Suisse SA Département INDRAMAT Rue du village 1 CH-1020 Renens</p> <p>Telefon: +41 (0)21/632 84 20 Telefax: +41 (0)21/632 84 21</p>		

Europäische Kundenbetreuungsstellen (ohne Deutschland)
 European Service agencies (without Germany)

Außerhalb Europa - outside Europe

vom Ausland:
from abroad:

(0) nach Landeskenziffer weglassen!
don't dial (0) after country code!

<p>Argentina <input checked="" type="checkbox"/> SALES <input type="checkbox"/> Service</p> <p>Mannesmann Rexroth S.A.I.C. Division INDRAMAT Acassusso 48 41/7 RA - 1605 Munro (Buenos Aires) Telefon: +54 (0)11/4756 01 40 Telefax: +54 (0)11/4762 6862 e-mail:mannesmann@impsat1.com.ar</p>	<p>Argentina <input checked="" type="checkbox"/> SALES <input checked="" type="checkbox"/> Service</p> <p>NAKASE Servicio Tecnico CNC Calle 49, No. 5764/66 RA - 1653 Villa Balester Prov. - Buenos Aires Telefon: +54 (0) 11/4768 36 43 Telefax: +54 (0) 11/4768 24 13 e-mail: nakase@usa.net nakase@infovia.com.ar</p>	<p>Australia <input checked="" type="checkbox"/> SALES <input checked="" type="checkbox"/> Service</p> <p>AIMS - Australian Industrial Machinery Services Pty. Ltd. Unit 3/45 Horne ST Campbellfield , VIC 3061 AUS - Melbourne Telefon: +61 (0)3/93 59 02 28 Telefax: +61 (0)3/93 59 02 86</p>	<p>Australia <input checked="" type="checkbox"/> SALES <input type="checkbox"/> Service</p> <p>Mannesmann Rexroth Pty. Ltd. No. 7, Endeavour Way Braeside Victoria, 31 95 AUS - Melbourne Telefon: +61 (0)3/95 80 39 33 Telefax: +61 (0)3/95 80 17 33 Email: mel@rexroth.com.au</p>
<p>Brazil <input checked="" type="checkbox"/> SALES <input checked="" type="checkbox"/> Service</p> <p>Mannesmann Rexroth Automação Ltda. Divisão INDRAMAT Rua Georg Rexroth, 609 Vila Padre Anchieta BR - 09951-270 Diadema-SP [Caixa Postal 377] [BR-09901-970 Diadema-SP] Telefon: +55 (0)11/745 90 60 +55 (0)11/745 90 70 Telefax: +55 (0)11/745 90 50 e-mail: awittwer@rexroth.com.br</p>	<p>Brazil <input type="checkbox"/> SALES <input checked="" type="checkbox"/> Service</p> <p>Mannesmann Rexroth Automação Ltda. Divisão INDRAMAT R. Dr.Humberto Pinheiro Vieira, 100 Distrito Industrial BR - 89220-390 Joinville - SC [Caixa Postal 1273] Tel./Fax: +55 (0)47/473 58 33 Mobil: +55 (0)47 974 66 45 e-mail: prochnow@zaz.com.br</p>	<p>Canada <input checked="" type="checkbox"/> SALES <input checked="" type="checkbox"/> Service</p> <p>Basic Technologies Corporation Burlington Division 3426 Mainway Drive Burlington, Ontario Canada L7M 1A8 Telefon: +1 905/335 55 11 Telefax: +1 905/335-41 84</p>	<p>China <input type="checkbox"/> SALES <input checked="" type="checkbox"/> Service</p> <p>Mannesmann Rexroth (China) Ltd. Shanghai Parts & Service Center 199 Wu Cao Road, Hua Cao Minhang District PRC - Shanghai 201 103 Telefon: +86 21/62 20 00 58 Telefax: +86 21/62 20 00 68</p>
<p>China <input checked="" type="checkbox"/> SALES <input type="checkbox"/> Service</p> <p>Mannesmann Rexroth (China) Ltd. 15/F China World Trade Center 1, Jianguomenwai Avenue PRC - Beijing 100004 Telefon: +86 10/65 05 03 80 Telefax: +86 10/65 05 03 79</p>	<p>China <input checked="" type="checkbox"/> SALES <input type="checkbox"/> Service</p> <p>Mannesmann Rexroth (China) Ltd. A-5F., 123 Lian Shan Street Sha He Kou District PRC - Dalian 116 023 Telefon: +86 411/46 78 930 Telefax: +86 411/46 78 932</p>	<p>Hongkong <input checked="" type="checkbox"/> SALES <input checked="" type="checkbox"/> Service</p> <p>Rexroth (China) Ltd. 1/F., 19 Cheung Shun Street Cheung Sha Wan, Kowloon, Hongkong Telefon: +852 22 62 51 00 Telefax: +852 27 44 02 78</p>	<p>India <input checked="" type="checkbox"/> SALES <input checked="" type="checkbox"/> Service</p> <p>Mannesmann Rexroth (India) Ltd. INDRAMAT Division Plot. 96, Phase III Peenya Industrial Area IND - Bangalore - 560058 Telefon: +91 (0)80/8 39 73 74 Telefax: +91 (0)80/8 39 43 45</p>
<p>India <input checked="" type="checkbox"/> SALES <input checked="" type="checkbox"/> Service</p> <p>Mannesmann Rexroth (India) Ltd. INDRAMAT Division Plot. A-58, TTC Industrial Area Thane Turbhe Midc Road Mahape Village IND - Navi Mumbai - 400 701 Telefon: +91 (0)22/7 61 46 22 Telefax: +91 (0)22/7 68 15 31</p>	<p>Indonesia <input checked="" type="checkbox"/> SALES <input type="checkbox"/> Service</p> <p>PT. Rexroth Wijayakusuma Jl. Raya Bekasi Km 21 Pulogadung RI - Jakarta Timur 13920 Telefon: +62 21/4 61 04 87 +62 21/4 61 04 88 Telefax: +62 21/4 60 01 52</p>	<p>Japan <input type="checkbox"/> SALES <input checked="" type="checkbox"/> Service</p> <p>Rexroth Automation Co., Ltd. Service Center Japan Yutakagaoka 1810, Meito-ku, NAGOYA 465-0035, Japan Telefon: +81 (0)52/777 88 41 +81 (0)52/777 88 53 +81 (0)52/777 88 79 Telefax: +81 (0)52/777 89 01</p>	<p>Japan <input checked="" type="checkbox"/> SALES <input checked="" type="checkbox"/> Service</p> <p>Rexroth Automation Co., Ltd. INDRAMAT Division 1F, I.R. Building Nakamachidai 4-26-44, Tsuzuki-ku YOKOHAMA 224-0041, Japan Telefon: +81 (0)45/942 72 10 Telefax: +81 (0)45/942 03 41</p>
<p>Mexico <input checked="" type="checkbox"/> SALES <input type="checkbox"/> Service</p> <p>Mannesmann Rexroth Mexico S.A. de C.V. Calle Neptuno 72 Unidad Ind. Vallejo MEX - 07700 Mexico, D.F. Telefon: +52 5 754 17 11 +52 5 754 36 84 +52 5 754 12 60 Telefax: +52 5 754 50 73 +52 5 752 59 43 e-mail: gSORIA@rexroth-mexico.com</p>	<p>Korea <input checked="" type="checkbox"/> SALES <input checked="" type="checkbox"/> Service</p> <p>Mannesmann Rexroth-Seki Co Ltd. 1500-12 Da-Dae-Dong ROK - Saha-Ku, Pusan, 604-050 Telefon: +82 (0)51/2 60 06 18 Telefax: +82 (0)51/2 60 06 19</p>	<p>Korea <input checked="" type="checkbox"/> SALES <input checked="" type="checkbox"/> Service</p> <p>Seo Chang Corporation Ltd. Room 903, Jeail Building 44-35 Yeouido-Dong Yeoungdeungpo-Ku C.P.O.Box 97 56 ROK - Seoul Telefon: +82 (0)2/7 80 82 08 +82 (0)2/7 80 82 09 Telefax: +82 (0)2/7 84 54 08</p>	<p>South Africa <input checked="" type="checkbox"/> SALES <input checked="" type="checkbox"/> Service</p> <p>TECTRA Automation (Pty) Ltd. 28 Banfield Road, Industria North RSA - Maraisburg 1700 Telefon: +27 (0)11/673 20 80 Telefax: +27 (0)11/673 72 69</p>
<p>Taiwan <input checked="" type="checkbox"/> SALES <input type="checkbox"/> Service</p> <p>Rexroth Uchida Co., Ltd. No.1, Tsu Chiang Street Tu Cheng Ind. Estate Taipei Hsien, Taiwan, R.O.C. Telefon: +886 2/2 68 13 47 Telefax: +886 2/2 68 53 88</p>			

Kundenbetreuungsstellen außerhalb Europa - Service agencies outside Europe

Außerhalb Europa / USA - outside Europe / USA

<p>USA <input checked="" type="checkbox"/> SALES <input checked="" type="checkbox"/> Service</p> <p>Mannesmann Rexroth Corporation INDRAMAT Division 5150 Prairie Stone Parkway USA -Hoffman Estates, IL 60192-3707</p> <p>Telefon: +1 847/6 45 36 00 Telefax: +1 847/6 45 62 01</p> <p>E-MAIL: service@indramat.com</p> <p>Service HOTLINE: +1-800-860-1055 -7 days/24hrs-</p>	<p>USA <input checked="" type="checkbox"/> SALES <input checked="" type="checkbox"/> Service</p> <p>Mannesmann Rexroth Corporation INDRAMAT Division Central Region Technical Center USA - Auburn Hills, MI 48326</p> <p>Telefon: +1 248/3 93 33 30 Telefax: +1 248/3 93 29 06</p>	<p>USA <input checked="" type="checkbox"/> SALES <input checked="" type="checkbox"/> Service</p> <p>Mannesmann Rexroth Corporation INDRAMAT Division Southeastern Technical Center 3625 Swiftwater Park Drive USA - Suwanee Georgia 30174</p> <p>Telefon: +1 770/9 32 32 00 +1 770/9 32 19 03</p>	<p>USA <input checked="" type="checkbox"/> SALES <input checked="" type="checkbox"/> Service</p> <p>Mannesmann Rexroth Corporation INDRAMAT Division Northeastern Technical Center 99 Rainbow Road USA - East Granby, Connecticut 06026</p> <p>Telefon: +1 860/8 44 83 77 +1 860/8 44 85 95</p>
<p>USA <input checked="" type="checkbox"/> SALES <input checked="" type="checkbox"/> Service</p> <p>Mannesmann Rexroth Corporation INDRAMAT Division Charlotte Regional Sales Office 14001 South Lakes Drive USA - Charlotte, North Carolina 28273</p> <p>Telefon: +1 704/5 83 97 62 +1 704/5 83 14 86</p>			

Kundenbetreuungsstellen außerhalb Europa / USA
Service agencies outside Europe / USA

Notes

