



# RECO Inline IBS Terminals and Module Supply

Functional Description

SYSTEM200

<b>Title</b>	RECO Inline IBS Terminals and Module Supply
<b>Type of Documentation</b>	Functional Description
<b>Document Typecode</b>	DOK-CONTRL-R-IL-IBS-BK-FK02-EN-P
<b>Internal File Reference</b>	Document Number: 120-0400-B340-02/EN
<b>Purpose of Documentation</b>	This documentation serves <ul style="list-style-type: none"> <li>• as general information for the module terminals,</li> <li>• to specify the technical data,</li> <li>• to specify diagrams and formulas,</li> <li>• as reference book for detailed information.</li> </ul>

**Record of Revisions**

Description	Release Date	Notes
120-0400-B340-02/EN	11/01	First English issue

**Copyright** © 20001, Rexroth Indramat GmbH

Copying this document, giving it to others and the use or communication of the contents thereof without express authority, are forbidden. Offenders are liable for the payment of damages. All rights are reserved in the event of the grant of a patent or the registration of a utility model or design (DIN 34-1).

**Validity** The specified data is for product description purposes only and may not be deemed to be guaranteed unless expressly confirmed in the contract. All rights are reserved with respect to the content of this documentation and the availability of the product.

**Published by** Rexroth Indramat GmbH  
Bgm.-Dr.-Nebel-Str. 2 • D-97816 Lohr a. Main  
Telephone +49 (0)93 52/40-0 • Tx 68 94 21 • Fax +49 (0)93 52/40-48 85  
<http://www.boschrexroth.de/>  
Dept. EP7 (CH)  
Dept. EP6 (UK)  
Dept. EP (NH)

**Note** This document has been printed on chlorine-free bleached paper.

# Contents

<b>1</b>	<b>Introduction of Components</b>	<b>1-1</b>
1.1	Description and Basic Functions.....	1-1
<b>2</b>	<b>Important Directions for Use</b>	<b>2-1</b>
2.1	Appropriate Use .....	2-1
	Introduction .....	2-1
	Areas of Use and Application.....	2-2
2.2	Inappropriate Use.....	2-2
<b>3</b>	<b>Safety Instructions for Electric Drives and Controls</b>	<b>3-1</b>
3.1	Introduction.....	3-1
3.2	Explanations.....	3-1
3.3	Hazards by Improper Use .....	3-2
3.4	General Information .....	3-3
3.5	Protection Against Contact with Electrical Parts.....	3-5
3.6	Protection Against Electric Shock by Protective Low Voltage (PELV).....	3-6
3.7	Protection Against Dangerous Movements.....	3-7
3.8	Protection Against Magnetic and Electromagnetic Fields During Operation and Mounting .....	3-9
3.9	Protection Against Contact with Hot Parts .....	3-10
3.10	Protection During Handling and Mounting .....	3-10
3.11	Battery Safety.....	3-11
3.12	Protection Against Pressurized Systems .....	3-11
<b>4</b>	<b>Remote Bus Terminal R-IBS IL 24 BK-T</b>	<b>4-1</b>
4.1	Description and Intended Use.....	4-1
	Features.....	4-1
	Indicator Elements .....	4-2
4.2	Technical Data .....	4-3
	General Data.....	4-3
	INTERBUS Interfaces .....	4-3
	Data of Voltage Supply .....	4-4
4.3	Connections .....	4-7
	Position of Terminals .....	4-7
	Terminal Assignment .....	4-7
	Voltage Supply.....	4-10
	Internal Block Diagram.....	4-11
	Connection Example.....	4-12
	Programming Data.....	4-13

4.4	Electric Isolation .....	4-14
4.5	Diagrams and Formulas .....	4-16
	Derating.....	4-16
	Power Loss .....	4-17
<b>5</b>	<b>Remote Bus Terminal R-IBS IL 24 RB-T</b>	<b>5-1</b>
5.1	Description and Intended Use.....	5-1
	Features .....	5-1
	Indicator Elements .....	5-2
5.2	Technical Data .....	5-3
	General Data.....	5-3
	INTERBUS Interfaces .....	5-3
5.3	Connections .....	5-4
	Position of Terminals .....	5-4
	Terminal Assignment .....	5-4
	Internal Block Diagram.....	5-5
	Connection Example.....	5-6
	Programming Data .....	5-6
5.4	Electric Isolation .....	5-7
	Potentials of the Terminal .....	5-7
	Potentials in Case of Combined Terminals.....	5-7
5.5	Diagrams and Formulas.....	5-7
	Power Loss .....	5-7
<b>6</b>	<b>Power Terminal R-IB IL PWR IN</b>	<b>6-1</b>
6.1	Description and Intended Use.....	6-1
	Features .....	6-1
	Indicator Elements .....	6-2
6.2	Technical Data .....	6-3
6.3	Connections .....	6-4
	Position of Terminals .....	6-4
	Terminal Assignment .....	6-4
	Internal Block Diagram.....	6-5
	Connection Example.....	6-6
6.4	Electric Isolation .....	6-7
<b>7</b>	<b>Segment Terminal</b>	<b>7-1</b>
7.1	Description and Intended Use.....	7-1
	Features .....	7-1
	Indicator Elements .....	7-2
7.2	Technical Data .....	7-3
7.3	Connections .....	7-4
	Position of Terminals .....	7-4
	Terminal Assignment .....	7-4
	Internal Block Diagram.....	7-5
7.4	Electric Isolation .....	7-6

7.5	Diagrams and Formulas.....	7-7
	Derating.....	7-7
	Voltage Characteristics in the Segment Circuit with a Defective Use .....	7-7
	Power Loss .....	7-9
<b>8</b>	<b>Ordering Information</b>	<b>8-1</b>
8.1	Ordering Names.....	8-1
<b>9</b>	<b>List of Figures</b>	<b>9-1</b>
<b>10</b>	<b>Index</b>	<b>10-1</b>
<b>11</b>	<b>Service &amp; Support</b>	<b>11-1</b>
11.1	Helpdesk .....	11-1
11.2	Service-Hotline.....	11-1
11.3	Internet .....	11-1
11.4	Vor der Kontaktaufnahme... - Before contacting us.....	11-1
11.5	Kundenbetreuungsstellen - Sales & Service Facilities .....	11-2



# 1 Introduction of Components

## 1.1 Description and Basic Functions

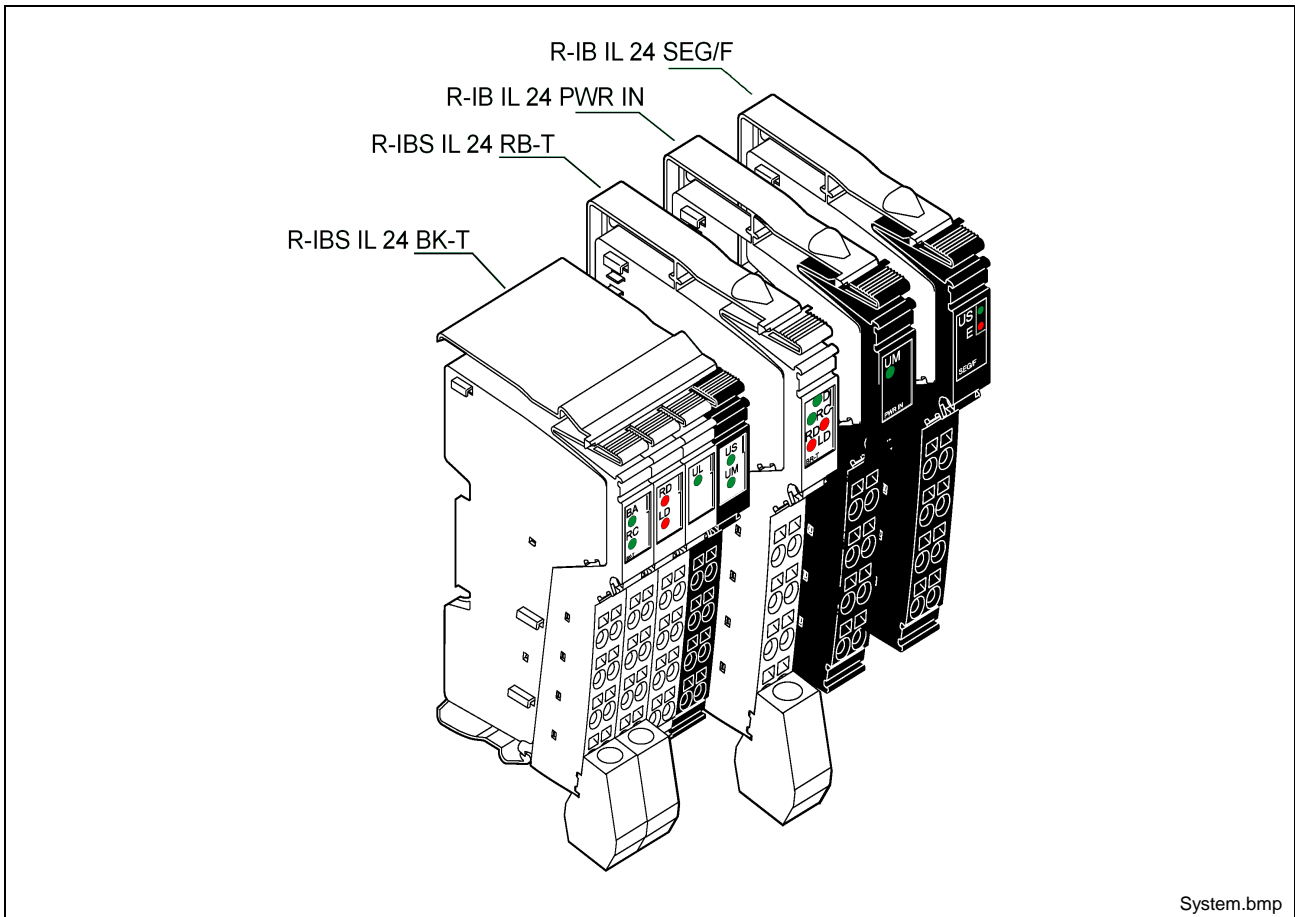

Fig. 1-1: Remote bus terminals and supply modules

The description covers the following components:

- INTERBUS Inline bus terminal

R-IBS IL 24 BK-T

The bus terminal couples an Inline station to the INTERBUS remote bus and makes the supply voltages available to the connected devices.

- INTERBUS Inline terminal for connection of a remote bus branch

R-IBS IL 24 RB-T

Using this terminal, a remote bus branch can be branched off from the RECO Inline station. This allows integration of remote devices, such as indicator and button fields, motor switches with IP 65 degree of protection, or sensor/actuator boxes, into the INTERBUS via an Inline station.

- INTERBUS Inline power terminal without fuse

R-IB IL 24 PWR IN

The terminal permits feeding of supply voltages into the main circuit. In addition, the supply for a segment circuit can be made available at this terminal.

- INTERBUS Inline segment terminal with fuse

R-IB IL 24 SEG/F

The terminal permits setting up of a protected partial circuit (segment circuit) within the main circuit. It is not provided for voltage supply. For that reason, it does not contain any elements protecting against polarity reversal and overvoltage.

---

**Note:** This functional description is applicable only in connection with the application description "Project Planning and Installation of the Module Family Inline" DOK-CONTRL-R-IL\*IBSSYS.

---

## 2 Important Directions for Use

### 2.1 Appropriate Use

#### Introduction

Rexroth Indramat products represent state-of-the-art developments and manufacturing. They are tested prior to delivery to ensure operating safety and reliability.

The products may only be used in the manner that is defined as appropriate. If they are used in an inappropriate manner, then situations can develop that may lead to property damage or injury to personnel.

---

**Note:** Rexroth Indramat, as manufacturer, is not liable for any damages resulting from inappropriate use. In such cases, the guarantee and the right to payment of damages resulting from inappropriate use are forfeited. The user alone carries all responsibility of the risks.

---

Before using Rexroth Indramat products, make sure that all the prerequisites for appropriate use of the products are satisfied:

Personnel that in any way, shape or form uses our products must first read and understand the relevant safety instructions and be familiar with appropriate use.

If the product takes the form of hardware, then they must remain in their original state, in other words, no structural changes are permitted. It is not permitted to decompile software products or alter source codes.

- Do not mount damaged or faulty products or use them in operation.
- Make sure that the products have been installed in the manner described in the relevant documentation.

## Areas of Use and Application

The RECO Inline system is a decentralized modular fieldbus-coupled input and output system.

The RECO Inline system by Rexroth Indramat is intended for the cases of use listed below.

Machine tools

Transfer systems

General automation

---

**Note:** The RECO Inline system may only be used with the accessories and parts specified in this document. If a component has not been specifically named, then it may not be either mounted or connected. The same applies to cables and lines.

Operation is only permitted in the specified configurations and combinations of components using the software and firmware as specified in the relevant functional descriptions.

---

The typical fields of application of RECO Inline modules are as follows:

- Turning machines
- Milling machines
- Machining centers

General automation

The RECO Inline system may only be operated under the assembly, installation and ambient conditions as described here (temperature, system of protection, humidity, EMC requirements, etc.) and in the position specified.

## 2.2 Inappropriate Use

Using the RECO Inline system outside of the above-referenced areas of application or under operating conditions other than described in the document and the technical data specified is defined as "inappropriate use".

The RECO Inline system may not be used if

they are subject to operating conditions that do not meet the above specified ambient conditions. This includes, for example, operation under water, in the case of extreme temperature fluctuations or extreme maximum temperatures or if

Rexroth Indramat has not specifically released them for that intended purpose. Please note the specifications outlined in the general Safety Instructions!

### 3 Safety Instructions for Electric Drives and Controls

#### 3.1 Introduction

Read these instructions before the initial startup of the equipment in order to eliminate the risk of bodily harm or material damage. Follow these safety instructions at all times.

Do not attempt to install or start up this equipment without first reading all documentation provided with the product. Read and understand these safety instructions and all user documentation of the equipment prior to working with the equipment at any time. If you do not have the user documentation for your equipment, contact your local Rexroth Indramat representative to send this documentation immediately to the person or persons responsible for the safe operation of this equipment.

If the equipment is resold, rented or transferred or passed on to others, then these safety instructions must be delivered with the equipment.



**Improper use of this equipment, failure to follow the safety instructions in this document or tampering with the product, including disabling of safety devices, may result in material damage, bodily harm, electric shock or even death!**

#### 3.2 Explanations

The safety instructions describe the following degrees of hazard seriousness in compliance with ANSI Z535. The degree of hazard seriousness informs about the consequences resulting from non-compliance with the safety instructions.

Warning symbol with signal word	Degree of hazard seriousness according to ANSI
<p><b>DANGER</b></p>	Death or severe bodily harm will occur.
<p><b>WARNING</b></p>	Death or severe bodily harm may occur.
<p><b>CAUTION</b></p>	Bodily harm or material damage may occur.

Fig. 3-1: Hazard classification (according to ANSI Z535)

### 3.3 Hazards by Improper Use



**DANGER**

**High voltage and high discharge current!  
Danger to life or severe bodily harm by electric shock!**



**DANGER**

**Dangerous movements! Danger to life, severe bodily harm or material damage by unintentional motor movements!**



**WARNING**

**High electrical voltage due to wrong connections! Danger to life or bodily harm by electric shock!**



**WARNING**

**Health hazard for persons with heart pacemakers, metal implants and hearing aids in proximity to electrical equipment!**



**CAUTION**

**Surface of machine housing could be extremely hot! Danger of injury! Danger of burns!**



**CAUTION**

**Risk of injury due to improper handling! Bodily harm caused by crushing, shearing, cutting and mechanical shock or incorrect handling of pressurized systems!**



**CAUTION**

**Risk of injury due to incorrect handling of batteries!**

## 3.4 General Information

- Rexroth Indramat GmbH is not liable for damages resulting from failure to observe the warnings provided in this documentation.
- Read the operating, maintenance and safety instructions in your language before starting up the machine. If you find that you cannot completely understand the documentation for your product, please ask your supplier to clarify.
- Proper and correct transport, storage, assembly and installation as well as care in operation and maintenance are prerequisites for optimal and safe operation of this equipment.
- Only persons who are trained and qualified for the use and operation of the equipment may work on this equipment or within its proximity.
  - The persons are qualified if they have sufficient knowledge of the assembly, installation and operation of the equipment as well as an understanding of all warnings and precautionary measures noted in these instructions.
  - Furthermore, they must be trained, instructed and qualified to switch electrical circuits and equipment on and off in accordance with technical safety regulations, to ground them and to mark them according to the requirements of safe work practices. They must have adequate safety equipment and be trained in first aid.
- Only use spare parts and accessories approved by the manufacturer.
- Follow all safety regulations and requirements for the specific application as practiced in the country of use.
- The equipment is designed for installation in industrial machinery.
- The ambient conditions given in the product documentation must be observed.
- Use only safety features and applications that are clearly and explicitly approved in the Project Planning Manual.  
For example, the following areas of use are not permitted: construction cranes, elevators used for people or freight, devices and vehicles to transport people, medical applications, refinery plants, transport of hazardous goods, nuclear applications, applications sensitive to high frequency, mining, food processing, control of protection equipment (also in a machine).
- The information given in the documentation of the product with regard to the use of the delivered components contains only examples of applications and suggestions.  
The machine and installation manufacturer must
  - make sure that the delivered components are suited for his individual application and check the information given in this documentation with regard to the use of the components,
  - make sure that his application complies with the applicable safety regulations and standards and carry out the required measures, modifications and complements.
- Startup of the delivered components is only permitted once it is sure that the machine or installation in which they are installed complies with the national regulations, safety specifications and standards of the application.

- Operation is only permitted if the national EMC regulations for the application are met.  
The instructions for installation in accordance with EMC requirements can be found in the documentation "EMC in Drive and Control Systems".  
The machine or installation manufacturer is responsible for compliance with the limiting values as prescribed in the national regulations.
- Technical data, connections and operational conditions are specified in the product documentation and must be followed at all times.

## 3.5 Protection Against Contact with Electrical Parts

---

**Note:** This section refers to equipment and drive components with voltages above 50 Volts.

---

Touching live parts with voltages of 50 Volts and more with bare hands or conductive tools or touching ungrounded housings can be dangerous and cause electric shock. In order to operate electrical equipment, certain parts must unavoidably have dangerous voltages applied to them.

---



**DANGER**

### **High electrical voltage! Danger to life, severe bodily harm by electric shock!**

- ⇒ Only those trained and qualified to work with or on electrical equipment are permitted to operate, maintain or repair this equipment.
  - ⇒ Follow general construction and safety regulations when working on high voltage installations.
  - ⇒ Before switching on power the ground wire must be permanently connected to all electrical units according to the connection diagram.
  - ⇒ Do not operate electrical equipment at any time, even for brief measurements or tests, if the ground wire is not permanently connected to the points of the components provided for this purpose.
  - ⇒ Before working with electrical parts with voltage higher than 50 V, the equipment must be disconnected from the mains voltage or power supply. Make sure the equipment cannot be switched on again unintended.
  - ⇒ The following should be observed with electrical drive and filter components:
    - ⇒ Wait five (5) minutes after switching off power to allow capacitors to discharge before beginning to work. Measure the voltage on the capacitors before beginning to work to make sure that the equipment is safe to touch.
    - ⇒ Never touch the electrical connection points of a component while power is turned on.
    - ⇒ Install the covers and guards provided with the equipment properly before switching the equipment on. Prevent contact with live parts at any time.
    - ⇒ A residual-current-operated protective device (RCD) must not be used on electric drives! Indirect contact must be prevented by other means, for example, by an overcurrent protective device.
    - ⇒ Electrical components with exposed live parts and uncovered high voltage terminals must be installed in a protective housing, for example, in a control cabinet.
-

To be observed with electrical drive and filter components:



**DANGER**

**High electrical voltage on the housing!  
High leakage current! Danger to life, danger of  
injury by electric shock!**

- ⇒ Connect the electrical equipment, the housings of all electrical units and motors permanently with the safety conductor at the ground points before power is switched on. Look at the connection diagram. This is even necessary for brief tests.
- ⇒ Connect the safety conductor of the electrical equipment always permanently and firmly to the supply mains. Leakage current exceeds 3.5 mA in normal operation.
- ⇒ Use a copper conductor with at least 10 mm<sup>2</sup> cross section over its entire course for this safety conductor connection!
- ⇒ Prior to startups, even for brief tests, always connect the protective conductor or connect with ground wire. Otherwise, high voltages can occur on the housing that lead to electric shock.

### 3.6 Protection Against Electric Shock by Protective Low Voltage (PELV)

All connections and terminals with voltages between 0 and 50 Volts on Rexroth Indramat products are protective low voltages designed in accordance with international standards on electrical safety.



**WARNING**

**High electrical voltage due to wrong  
connections! Danger to life, bodily harm by  
electric shock!**

- ⇒ Only connect equipment, electrical components and cables of the protective low voltage type (PELV = Protective Extra Low Voltage) to all terminals and clamps with voltages of 0 to 50 Volts.
- ⇒ Only electrical circuits may be connected which are safely isolated against high voltage circuits. Safe isolation is achieved, for example, with an isolating transformer, an opto-electronic coupler or when battery-operated.

### 3.7 Protection Against Dangerous Movements

Dangerous movements can be caused by faulty control of the connected motors. Some common examples are:

- improper or wrong wiring of cable connections
- incorrect operation of the equipment components
- wrong input of parameters before operation
- malfunction of sensors, encoders and monitoring devices
- defective components
- software or firmware errors

Dangerous movements can occur immediately after equipment is switched on or even after an unspecified time of trouble-free operation.

The monitoring in the drive components will normally be sufficient to avoid faulty operation in the connected drives. Regarding personal safety, especially the danger of bodily injury and material damage, this alone cannot be relied upon to ensure complete safety. Until the integrated monitoring functions become effective, it must be assumed in any case that faulty drive movements will occur. The extent of faulty drive movements depends upon the type of control and the state of operation.

**DANGER****Dangerous movements! Danger to life, risk of injury, severe bodily harm or material damage!**

- ⇒ Ensure personal safety by means of qualified and tested higher-level monitoring devices or measures integrated in the installation. Unintended machine motion is possible if monitoring devices are disabled, bypassed or not activated.
  - ⇒ Pay attention to unintended machine motion or other malfunction in any mode of operation.
  
  - ⇒ Keep free and clear of the machine's range of motion and moving parts. Possible measures to prevent people from accidentally entering the machine's range of motion:
    - use safety fences
    - use safety guards
    - use protective coverings
    - install light curtains or light barriers
  - ⇒ Fences and coverings must be strong enough to resist maximum possible momentum, especially if there is a possibility of loose parts flying off.
  - ⇒ Mount the emergency stop switch in the immediate reach of the operator. Verify that the emergency stop works before startup. Don't operate the machine if the emergency stop is not working.
  - ⇒ Isolate the drive power connection by means of an emergency stop circuit or use a starting lockout to prevent unintentional start.
  - ⇒ Make sure that the drives are brought to a safe standstill before accessing or entering the danger zone. Safe standstill can be achieved by switching off the power supply contactor or by safe mechanical locking of moving parts.
  - ⇒ Secure vertical axes against falling or dropping after switching off the motor power by, for example:
    - mechanically securing the vertical axes
    - adding an external braking/ arrester/ clamping mechanism
    - ensuring sufficient equilibration of the vertical axes
- The standard equipment motor brake or an external brake controlled directly by the drive controller are not sufficient to guarantee personal safety!

- ⇒ Disconnect electrical power to the equipment using a master switch and secure the switch against reconnection for:
    - maintenance and repair work
    - cleaning of equipment
    - long periods of discontinued equipment use
  - ⇒ Prevent the operation of high-frequency, remote control and radio equipment near electronics circuits and supply leads. If the use of such equipment cannot be avoided, verify the system and the installation for possible malfunctions in all possible positions of normal use before initial startup. If necessary, perform a special electromagnetic compatibility (EMC) test on the installation.
- 

### 3.8 Protection Against Magnetic and Electromagnetic Fields During Operation and Mounting

Magnetic and electromagnetic fields generated near current-carrying conductors and permanent magnets in motors represent a serious health hazard to persons with heart pacemakers, metal implants and hearing aids.

---



**WARNING**

#### **Health hazard for persons with heart pacemakers, metal implants and hearing aids in proximity to electrical equipment!**

- ⇒ Persons with heart pacemakers, hearing aids and metal implants are not permitted to enter the following areas:
    - Areas in which electrical equipment and parts are mounted, being operated or started up.
    - Areas in which parts of motors with permanent magnets are being stored, operated, repaired or mounted.
  - ⇒ If it is necessary for a person with a heart pacemaker to enter such an area, then a doctor must be consulted prior to doing so. Heart pacemakers that are already implanted or will be implanted in the future, have a considerable variation in their electrical noise immunity. Therefore there are no rules with general validity.
  - ⇒ Persons with hearing aids, metal implants or metal pieces must consult a doctor before they enter the areas described above. Otherwise, health hazards will occur.
-

### 3.9 Protection Against Contact with Hot Parts



CAUTION

**Housing surfaces could be extremely hot!  
Danger of injury! Danger of burns!**

- ⇒ Do not touch housing surfaces near sources of heat! Danger of burns!
- ⇒ After switching the equipment off, wait at least ten (10) minutes to allow it to cool down before touching it.
- ⇒ Do not touch hot parts of the equipment, such as housings with integrated heat sinks and resistors. Danger of burns!

### 3.10 Protection During Handling and Mounting

Under certain conditions, incorrect handling and mounting of parts and components may cause injuries.



CAUTION

**Risk of injury by incorrect handling! Bodily harm caused by crushing, shearing, cutting and mechanical shock!**

- ⇒ Observe general installation and safety instructions with regard to handling and mounting.
- ⇒ Use appropriate mounting and transport equipment.
- ⇒ Take precautions to avoid pinching and crushing.
- ⇒ Use only appropriate tools. If specified by the product documentation, special tools must be used.
- ⇒ Use lifting devices and tools correctly and safely.
- ⇒ For safe protection wear appropriate protective clothing, e.g. safety glasses, safety shoes and safety gloves.
- ⇒ Never stand under suspended loads.
- ⇒ Clean up liquids from the floor immediately to prevent slipping.

### 3.11 Battery Safety

Batteries contain reactive chemicals in a solid housing. Inappropriate handling may result in injuries or material damage.



**CAUTION**

#### **Risk of injury by incorrect handling!**

- ⇒ Do not attempt to reactivate discharged batteries by heating or other methods (danger of explosion and cauterization).
- ⇒ Never charge non-chargeable batteries (danger of leakage and explosion).
- ⇒ Never throw batteries into a fire.
- ⇒ Do not dismantle batteries.
- ⇒ Do not damage electrical components installed in the equipment.

**Note:** Be aware of environmental protection and disposal! The batteries contained in the product should be considered as hazardous material for land, air and sea transport in the sense of the legal requirements (danger of explosion). Dispose batteries separately from other waste. Observe the legal requirements in the country of installation.

### 3.12 Protection Against Pressurized Systems

Certain motors and drive controllers, corresponding to the information in the respective Project Planning Manual, must be provided with pressurized media, such as compressed air, hydraulic oil, cooling fluid and cooling lubricant supplied by external systems. Incorrect handling of the supply and connections of pressurized systems can lead to injuries or accidents. In these cases, improper handling of external supply systems, supply lines or connections can cause injuries or material damage.



**CAUTION**

#### **Danger of injury by incorrect handling of pressurized systems !**

- ⇒ Do not attempt to disassemble, to open or to cut a pressurized system (danger of explosion).
- ⇒ Observe the operation instructions of the respective manufacturer.
- ⇒ Before disassembling pressurized systems, release pressure and drain off the fluid or gas.
- ⇒ Use suitable protective clothing (for example safety glasses, safety shoes and safety gloves)
- ⇒ Remove any fluid that has leaked out onto the floor immediately.

**Note:** Environmental protection and disposal! The media used in the operation of the pressurized system equipment may not be environmentally compatible. Media that are damaging the environment must be disposed separately from normal waste. Observe the legal requirements in the country of installation.

## Notes

## 4 Remote Bus Terminal R-IBS IL 24 BK-T

### 4.1 Description and Intended Use

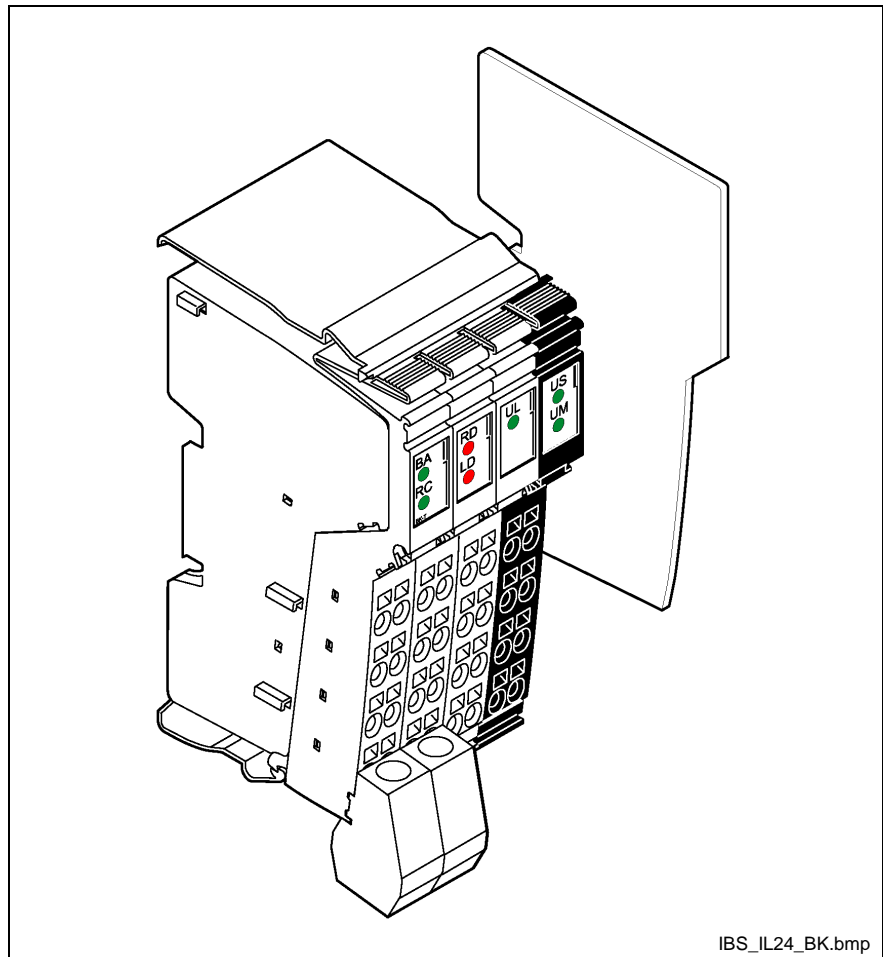

Fig. 4-1: Terminal R-IBS IL 24 BK-T with plugged-in connectors and end plate

The bus terminal couples an Inline station to the INTERBUS remote bus and makes the supply voltages available to the connected users.

### Features

- Remote bus connections made of copper
- All 24 V voltages required by an Inline station of the low signal level can be fed in.
- Galvanic isolation of remote bus segments
- Automatic configuration of the outgoing interface as remote-bus or local-bus interface

The end plate is enclosed to the bus terminal. Fit this plate as end plate of the Inline station. The end plate does not have any electrical function. It protects the station from ESD (ESD = electronic static discharge) pulses and the user from dangerous contact voltages.

## Indicator Elements

### Position of diagnostic indicators

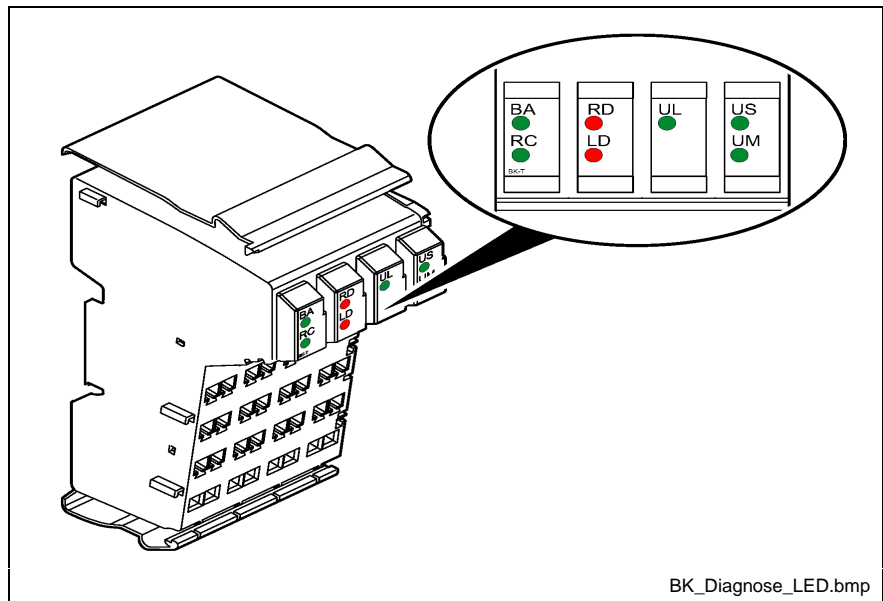

Fig. 4-2: Position of the diagnostic indicators of R-IBS IL 24 BK-T

### Meaning of diagnostic indicators

Name	Color	Meaning
BA	Green	Bus active
RC	Green	Remote bus cable check
RD	Red	Outgoing remote bus deactivated
LD	Red	Local bus deactivated
UL	Green	24 V bus terminal supply 7.5 V logic supply / interface supply
US	Green	24 V segment supply
UM	Green	24 V main supply

Fig. 4-3: Meaning of the diagnostic indicators of R-IBS IL 24 BK-T

## 4.2 Technical Data

### General Data

Housing dimensions	48.8 mm x 120 mm x 71.5 mm without connectors (W x H x D)	
Weight	142 g (without connectors)	
Permissible temperature	Operation Storage/transport	-25 °C up to +55 °C -25 °C up to +85 °C
Air humidity	Operation Storage/transport	75 % on average, 85 % occasionally 75 % on average, 85 % occasionally
Atmospheric pressure	Operation Storage/transport	80 kPa to 106 kPa (up to 2000 m above MSL) 76 kPa to 106 kPa (up to 3000 m above MSL)
Degree of protection	IP20 according to IEC 60529	
Safety classification	Classification 3, according to VDE 0106, IEC 60536	

Fig. 4-4: General technical data of R-IBS IL 24 BK-T

### INTERBUS Interfaces

<b>Remote bus</b>		
Incoming remote bus	Copper line (RS 422), connected via an Inline shield connector; electrically isolated supply; shield capacitively connected to the functional earth ground.	
Outgoing remote bus	Copper line (RS 422), connected via an Inline shield connector; electrically isolated supply; shield capacitively connected to the functional earth ground.	
Recommended cable lengths	See application description DOK-CONTRL-R-IL*IBSSYS	

Fig. 4-5: Technical data of the remote bus R-IBS IL 24 BK-T

<b>Local bus</b>		
Connection	Via data routing	
Level	5 V CMOS signal level	
Number of connectable Inline terminals	Limited by software	Max. 63
	Limited by power supply unit	Max. logic current consumption of the connected local bus modules: $I_{Max} \leq 2 \text{ A DC}$

Fig. 4-6: Technical data of the local bus R-IBS IL 24 BK-T

**Note: Observe the current consumption of the modules!**

When projecting an Inline station, the logic current consumption of each user must be observed! The respective value is specified in each module-specific data sheet. It can be different for the various modules. Accordingly, the potential number of users that can be connected depends on the specific setup of the station in question.

Functional data	
Reconfiguration (external)	If necessary, an external reconfiguration pushbutton can be connected to the bus terminal (for connection of the pushbutton see Fig. 4-19). When this pushbutton is actuated, a reconfiguration request to the connection assembly is triggered.
Interface configuration (internal)	When the next device is latched on, the interface is automatically configured by the bus terminal. If the next device is a terminal with remote bus branch, the interface is configured as remote bus interface. With any other device (e.g. I/O terminal), the interface is configured as local bus interface with diagnosis.

Fig. 4-7: Functional technical data of R-IBS IL 24 BK-T

## Data of Voltage Supply

24 V main supply / 24 V segment supply	
Connections	See Fig. 4-14
Connection method	Tension spring terminals
Recommended cable lengths	No more than 30 m; cable routing across exposed areas impermissible
Transmission	Via voltage routing
Special requirements for the voltage supply	The $U_M / U_S$ supply voltages are galvanically isolated from the bus terminal supply voltage $U_{BK}$ in case of a separate supply. This can be achieved only if two separate power supply units are used.
Behavior in the event of voltage dips and interruptions	The voltages (main and segment voltages) supplied from the bus terminal to the voltage jumpers follow the fed-in supply voltages without any delay.
Rated value	24 V DC
Tolerance	-15 % / +20% (according to EN 61131-2)
Ripple factor	± 5%
Permissible range	19.2 V to 30 V (including ripple factor)
Load capacity	No more than 8 A
Safety measures Overvoltage Polarity reversal	Yes Yes

Fig. 4-8: 24 V main supply / 24 V segment supply

---

**Note: Protect the 24 V range with an external fuse!**

The 24 V range must be protected by an external fuse. The power supply unit must be able to deliver the quadruple rated current of the external fusible cutout, to ensure that the fuse is safely blown in the event of a failure.

---

<b>24 V bus terminal supply</b>	
Connections	See Fig. 4-15
Connection method	Tension spring terminals
Recommended cable lengths	No more than 30 m; cable routing across exposed areas impermissible
Transmission	Via voltage routing
Special requirements for the voltage supply	The $U_M / U_S$ supply voltages are galvanically isolated from the bus terminal supply voltage $U_{BK}$ in case of a separate supply. This can be achieved only if two separate power supply units are used.
Rated value	24 V DC
Tolerance	-15 % / +20% (according to EN 61131-2)
Ripple factor	± 5%
Permissible range	19.2 V to 30 V (including ripple factor)
Minimum current consumption at rated voltage	0.1 A DC (When idling, i.e. the incoming remote bus is fitted, there are no connected local bus devices and the bus is inactive.)
Maximum current consumption at rated voltage	1.25 A DC Consisting of: 0.75 A DC for the logic supply 0.5 A DC for the analog voltage supply
Safety measures Overvoltage Polarity reversal	For the bus terminal supply only! Yes Yes

Fig. 4-9: 24 V bus terminal supply

**Note: Protect the 24 V range with an external fuse!**

The 24 V range must be protected by an external fuse. The power supply unit must be able to deliver the quadruple rated current of the external fusible cutout, to ensure that the fuse is safely blown in the event of a failure.

<b>24 V module supply</b>	
<b>Logic supply (voltage jumper)</b>	
Rated value	7.5 V DC
Tolerance	± 5%
Ripple factor	± 1.5%
Max. output current	2 A DC (consider derating)
Safety measures	Electronic protection against short-circuits
<b>Logic supply (interfaces; internal)</b>	
Rated value	2 times 5 V DC
Tolerance	± 5%
Ripple factor	± 1.5%
Max. output current	2 times 0.15 V DC
Safety measures	None
<b>Analog supply</b>	
Rated value	24 V DC
Tolerance	-15 % / +20 %
Ripple factor	± 5%
Max. output current	0.5 A DC (consider derating)
Safety measures	Electronic protection against short-circuits

Fig. 4-10: 24 V module supply

<b>Safety equipment</b>	
Overvoltage (Segment supply / main supply / bus terminal supply)	Input protection diodes (will be destroyed if overloaded permanently) Pulse loads up to 1500 W are short-circuited by the input protection diode.
Polarity reversal (Segment supply / main supply)	Parallel connected diodes as protection against polarity reversal; in case of an error, the high current through the diodes causes the series fusible cutout to fuse.
Polarity reversal (Bus terminal supply)	Serial diode in the supply path of the power supply unit; in case of an error, only a low current is flowing. In case of an error, no fuse is triggered in the external power supply unit. A 2-A protection must be ensured by the external power supply unit.

Fig. 4-11: Safety equipment of R-IBS IL 24 BK-T

### 4.3 Connections

#### Position of Terminals

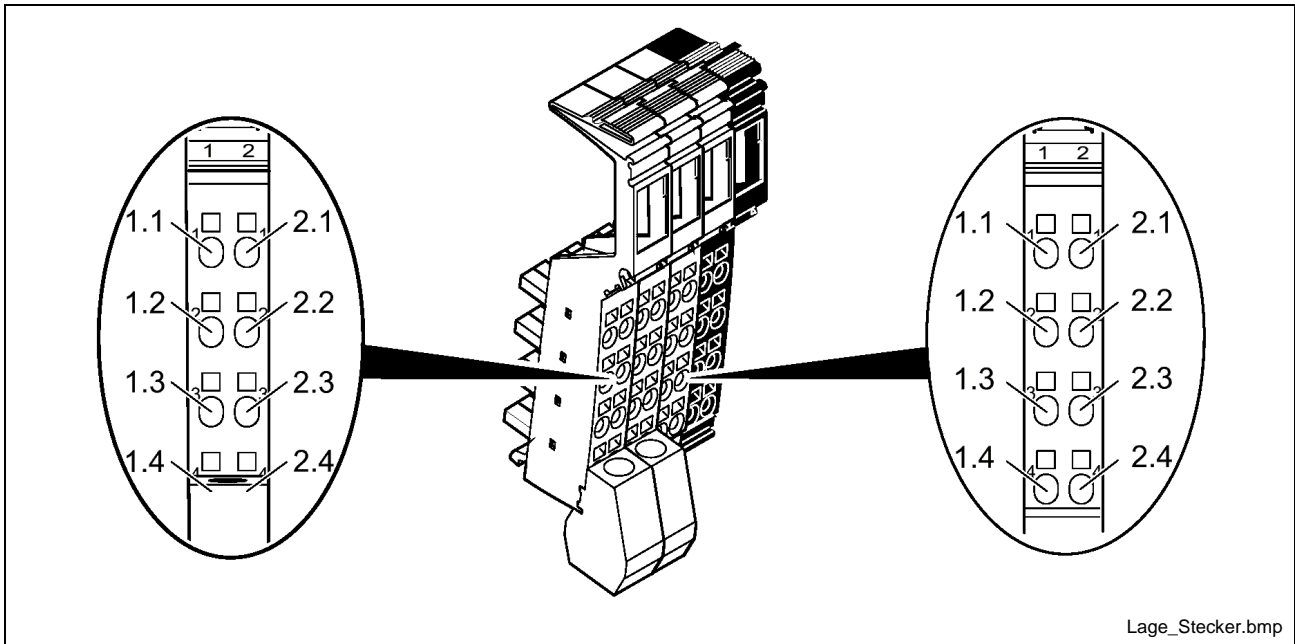

Fig. 4-12: Position of the R-IBS IL 24 BK-T terminals

#### Terminal Assignment

##### Connector 1 (incoming remote bus)

Terminal	Signal	Remark
1.1	/DO1	Receive
2.1	DO1	Receive
1.2	/DI1	Send
2.2	DI1	Send
1.3	F-GND	Reference potential
2.3	N.C.	
1.4	Shield	The shield potential is connected capacitively to the functional earth ground of the voltage jumper.
2.4	Shield	

Fig. 4-13: Terminal assignment of connector 1

### Connector 2 (outgoing remote bus)

Terminal	Signal	Remark
1.1	/DO2	Receive
2.1	DO2	Receive
1.2	/DI2	Send
2.2	DI2	Send
1.3	R-GND	Reference potential
2.3	N.C.	
1.4	Shield	The shield potential is connected directly to the functional earth ground of the voltage jumper.
2.4	Shield	

Fig. 4-14: Terminal assignment of connector 2

### Connector 3 (bus terminal supply)

Terminal	Signal	Remark
1.1, 2.1		Connection of the external reconfiguration pushbutton
1.2, 2.2	24 V DC	24 V bus terminal supply Supply of the bus terminal power supply unit
1.3, 2.3	BK-GND	Ground of the bus terminal supply This potential is provided as the ground reference for the bus terminal electronics.
1.4, 2.4	FE	Grounding of the bus terminals and, hence, of the Inline station; the contacts are connected directly to the voltage jumper and the FE spring on the housing bottom.

Fig. 4-15: Terminal assignment of connector 3

---

**Note:** The FE functional earth ground is only intended to discharge disturbances.

---

### Connector 4 (supply connector)

Terminal	Signal	Remark
1.1, 2.1	24 V DC	24 V segment supply The fed-in voltage is directly supplied on to the voltage jumper.
1.2, 2.2	24 V DC	24 V main supply The fed-in voltage is directly supplied on to the voltage jumper.
1.3, 2.3	GND	The reference potential is directly supplied on to the voltage jumper and is, at the same time, intended as the ground reference for the main and the segment supply.
1.4, 2.4	FE	Grounding of the bus terminals and, hence, the Inline station; the contacts are connected directly to the voltage jumper and the FE spring on the housing bottom.

Fig. 4-16: Terminal assignment of connector 4

---

**Note:** The FE functional earth ground is only intended to discharge disturbances.

---

---

**Note: Minimize any development of heat!**  
To feed in the main voltage and to feed in or branch the segment voltage, every two adjoining contacts must be used (see Fig. 4-19).

---

---

**Note: Observe the load capacity!**  
The maximum total current through the voltage jumpers is 8 A.

---

---

**Note: Ground the bus terminal!**  
Ground the bus terminal via one of the FE connections of connector 3 or connector 4. To achieve this, connect the appropriate contact to a grounding terminal (see Fig. 4-19).

---

## Voltage Supply

### 24 V main supply / 24 V segment supply

The reference potential of the segment supply must be the same as that of the main supply. As a consequence, it is not possible to provide an electrically isolated setup on the peripheral side.

Both the main supply and the segment supply are provided with elements protecting them against polarity reversal and transient overvoltage.

---

**Note:      Ensure short-circuit protection!**

Neither the main supply nor the segment supply is provided with elements protecting them from short-circuits.

---

It is the user's task to provide protection against short-circuits. The rating of the series fuse must be dimensioned such that it does not exceed the maximum permissible load current.

### 24 V segment supply

You can feed in or generate the segment voltage at the bus terminal or at one of the supply terminals.

The segment voltage can be made available at the bus terminal (on connector 4) in several ways:

1. Feed in the segment voltage at the terminal points 1.1/2.1 and 1.3/2.3 (GND) of the power connector separately (see picture 6).
2. Bridge the connectors 1.1/2.1 and 1.2/2.2 to ensure that the segment circuit is supplied from the main circuit.
3. Establish a switched segment circuit (this may, for instance, also be the E-STOP circuit) using a switch between the terminal points 1.1/2.1 and 1.2/2.2.

### 24 V bus terminal supply

The bus terminal supply is provided with elements as protection against polarity reversal and transient overvoltage. These elements are intended to protect the power supply unit only.

---

**Note:      Ensure short-circuit protection!**

The bus terminal supply is not provided with elements as protection against short-circuits.

---

It is the user's task to provide protection against short-circuits. The rating of the series fuse must be dimensioned such that it does not exceed the maximum permissible load current.

### Internal Block Diagram

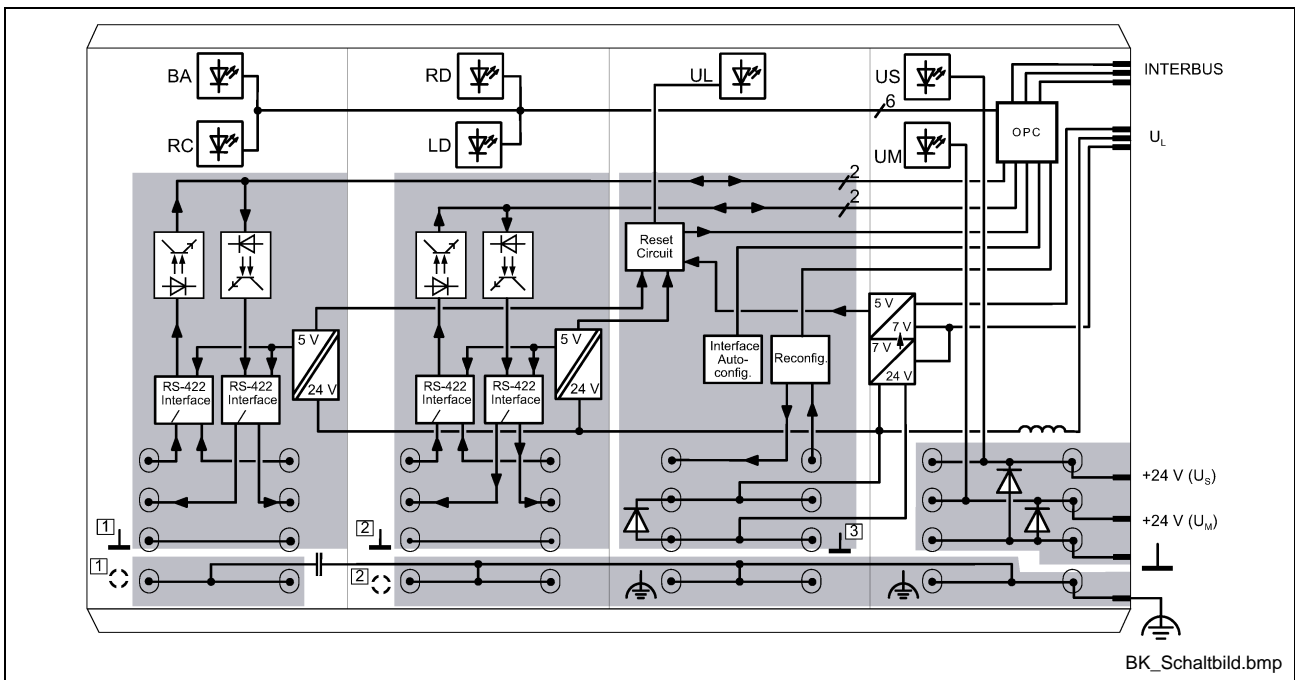

Fig. 4-17: Internal wiring of the terminal points of R-IBS IL 24 BK-T

### Definition of symbols

Symbol	Definition	Symbol	Definition
	Protocol chip (bus logic including voltage treatment)		BK-GND reference potential (bus terminal supply)
	LED		Shield potential; connected capacitively to the FE of the voltage jumper
	Optocoupler		Shield potential; connected directly to the FE of the voltage jumper
	Electrically isolated area		Interface module
	Galvanically isolated power supply unit		Voltage monitor
	Converter		Remote bus/local bus changeover switch
	F-GND reference potential (incoming interface)		Reconfiguration module
	R-GND reference potential (outgoing interface)		

Fig. 4-18: Definition of symbols

### Connection Example

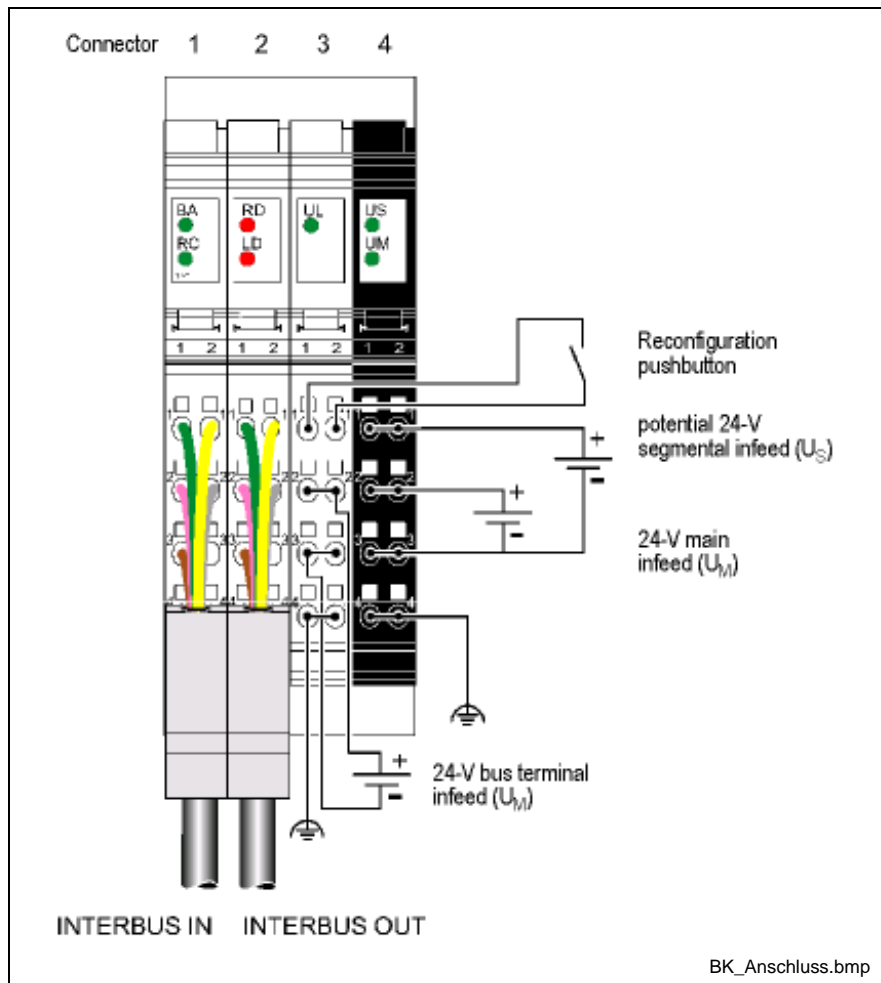

Fig. 4-19: Example of line connection to the bus terminal

**Note: Minimize any development of heat!**

To feed in the main voltage and to feed in or branch the segment voltage, every two adjoining contacts must be used.

Terminal	Signal	Remark	Color coding *
1.1	/DO1	Receive	Green
2.1	DO1	Receive	Yellow
1.2	/DI1	Send	Pink
2.2	DI1	Send	Grey
1.3	F-GND	Reference potential	Brown
2.3	N.C.		
1.4	Shield	The shield potential is connected capacitively to the functional earth ground of the voltage jumper.	
2.4	Shield		

Fig. 4-20: Color coding of connector 1

\* Colors according to certified INTERBUS cable

## Programming Data

ID code	04 <sub>hex</sub> (04 <sub>dec</sub> ) or 0C <sub>hex</sub> (12 <sub>dec</sub> )
Length code	00 <sub>hex</sub>
Input address space	0 bytes
Output address space	0 bytes
Parameter channel (PCP)	0 bytes
Register length (bus)	0 bytes

Fig. 4-21: Programming data of R-IBS IL 24 BK-T

---

**Note:** The bus terminal configures its outgoing interface automatically when the next device is latched on. If the next device is a terminal with remote bus branch, the bus terminal configures its outgoing interface as remote bus interface (0C<sub>hex</sub>). If the next device is not a terminal with remote bus branch, the bus terminal configures its outgoing interface as local bus interface (04<sub>hex</sub>).

---

### 4.4 Electric Isolation

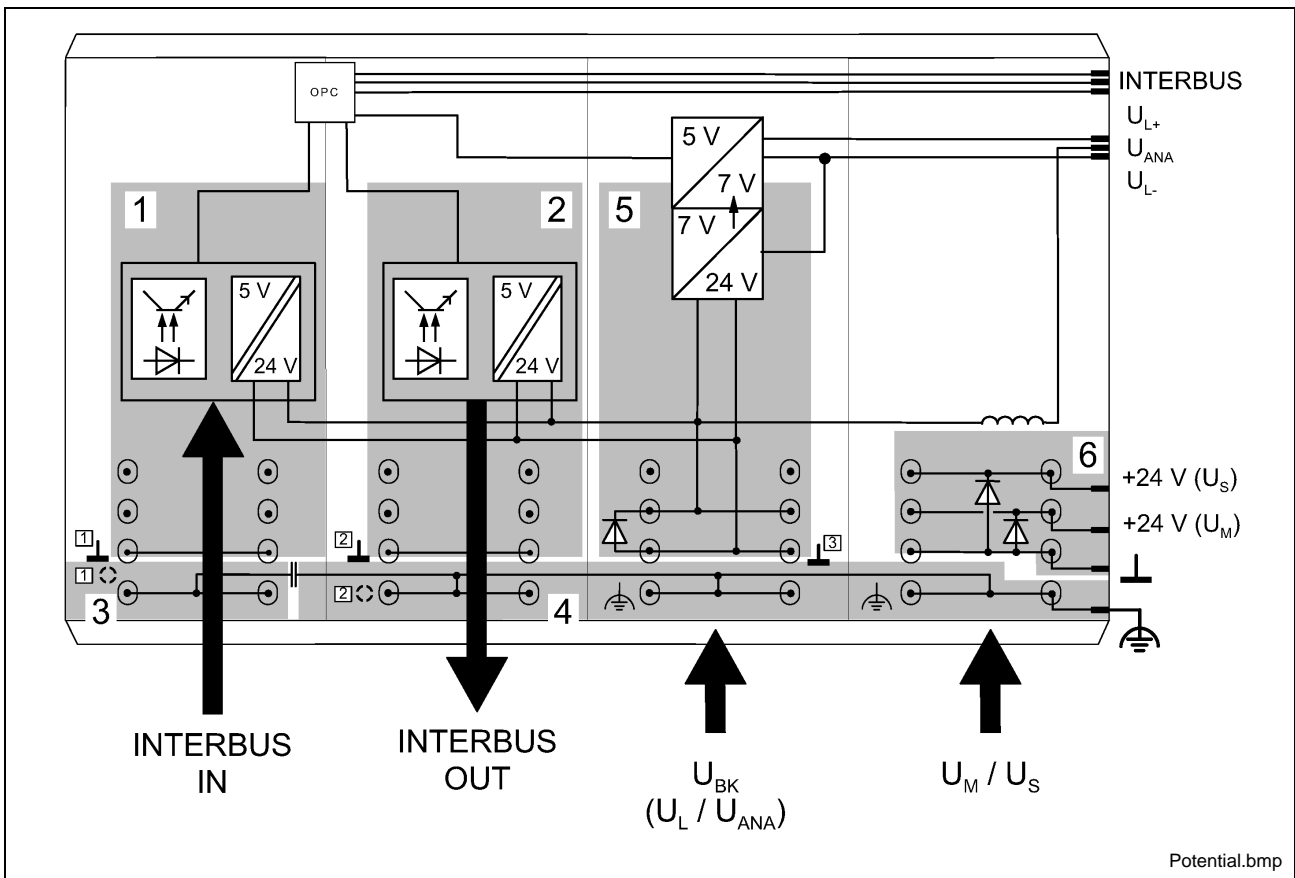

Fig. 4-22: Electric isolation of the various functional areas

Potential areas if separate power supply units are used to feed in  $U_{BK}$  and  $U_M / U_S$ :

1. Incoming remote bus
2. Outgoing remote bus
3. Functional earth ground (FE)
4. Functional earth ground (FE capacitive)
5. Bus terminal supply voltage  $U_{BK}$  with generation of the logic voltage  $U_L$  and supply of the analog terminals  $U_{ANA}$
6. Peripheral voltages  $U_M$  and  $U_S$

Common potentials	
If the 24 V bus terminal supply is provided separately from the 24 V main/24 V segment supply	Galvanically, the main and segment supplies are applied to the same potential. Their joint ground is supplied as GND reference ground from the bus terminal via the voltage jumper to the devices. Galvanically, the bus terminal supply, the analog supply and the 7.5 V logic supply are applied to the same potential. Their joint ground is supplied as LGND reference ground from the bus terminal via the voltage jumper to the devices.
If the 24 V bus terminal supply is provided by jumpering from the 24 V main/24 V segment supply	Galvanically, the main supply, the segment supply, the 24 V analog supply and the 7.5 V logic supply are applied to the same potential. From the bus terminal and via the voltage jumper, their joint ground is separately supplied to the devices, as LGND reference ground for the logic and analog supply and as GND reference ground for the supply and segment level.

Fig. 4-23: Common potentials of R-IBS IL 24 BK-T

<b>Isolated potentials</b>	
If the 24 V bus terminal supply is provided separately from the 24 V main/24 V segment supply	The bus terminal supply is spatially separated from the main and the segment supply and is, thus, electrically isolated. The interface supply voltages for the incoming and the outgoing remote busses are electrically isolated both against one another and against the supplies.
If the 24 V bus terminal supply is provided by jumpering from the 24 V main/24 V segment supply	The bus terminal is provided with two interface supply voltages for the incoming and the outgoing remote busses, which are galvanically isolated both against the primary/secondary supply and against one another. The main supply is galvanically isolated from interface supply voltages.

Fig. 4-24: Isolated potentials of R-IBS IL 24 BK-T

<b>Test section</b>	
5 V supply of incoming remote bus / 5 V supply of outgoing remote bus	500 V AC, 50 Hz, 1 min
5 V supply of incoming remote bus / 7.5 V logic supply, 24 V analog supply, 24 V bus terminal supply	500 V AC, 50 Hz, 1 min
5 V supply of incoming remote bus / 24 V main supply, 24 V segment supply	500 V AC, 50 Hz, 1 min
5 V supply of incoming remote bus / functional earth ground	500 V AC, 50 Hz, 1 min
5 V supply of outgoing remote bus / 7.5 V logic supply, 24 V analog supply, 24 V bus terminal supply	500 V AC, 50 Hz, 1 min
5 V supply of outgoing remote bus / 24 V main supply, 24 V segment supply	500 V AC, 50 Hz, 1 min
5 V supply of outgoing remote bus / functional earth ground	500 V AC, 50 Hz, 1 min
7.5 V logic supply, 24 V analog supply, 24 V bus terminal supply / functional earth ground	500 V AC, 50 Hz, 1 min
7.5 V logic supply, 24 V analog supply, 24 V bus terminal supply / 24 V main supply, 24 V segment supply	500 V AC, 50 Hz, 1 min
24 V main supply, 24 V segment supply / functional earth ground	500 V AC, 50 Hz, 1 min

Fig. 4-25: Test section of R-IBS IL 24 BK-T

## 4.5 Diagrams and Formulas

### Derating

Derating of the logic supply and the supply of the analog terminals:

- with a current load of the peripheral supply at the bus terminal of no more than 8 A

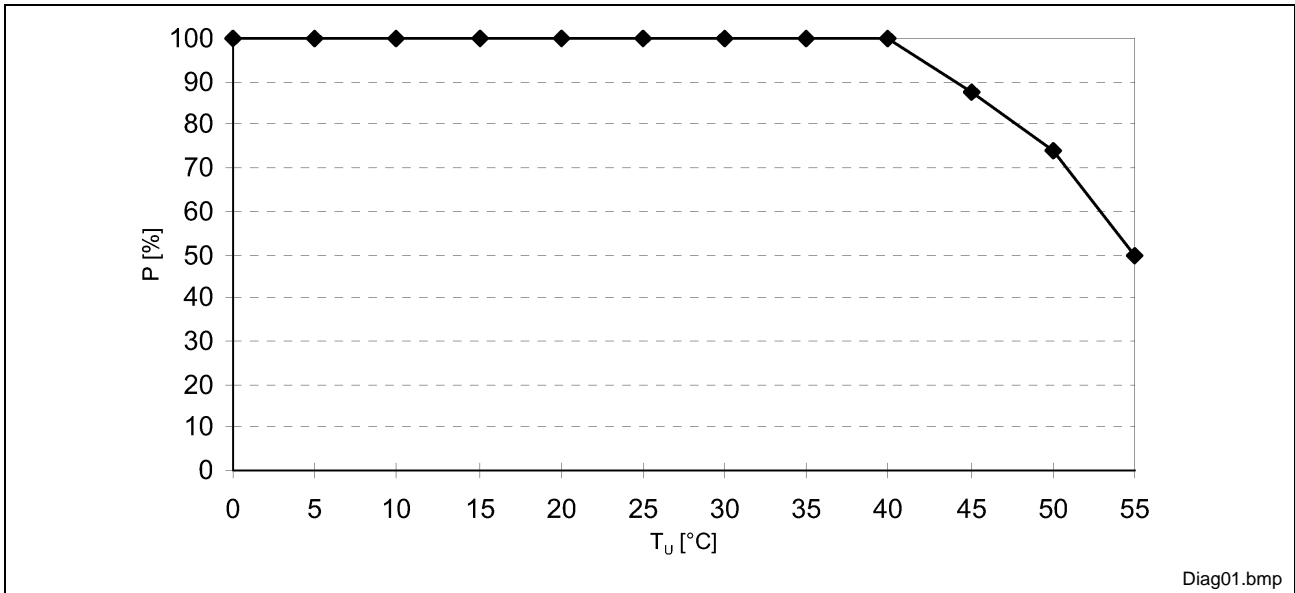

Fig. 4-26: Diagram of derating with a current load of no more than 8 A

- with a current load of the peripheral supply at the bus terminal of no more than 4 A

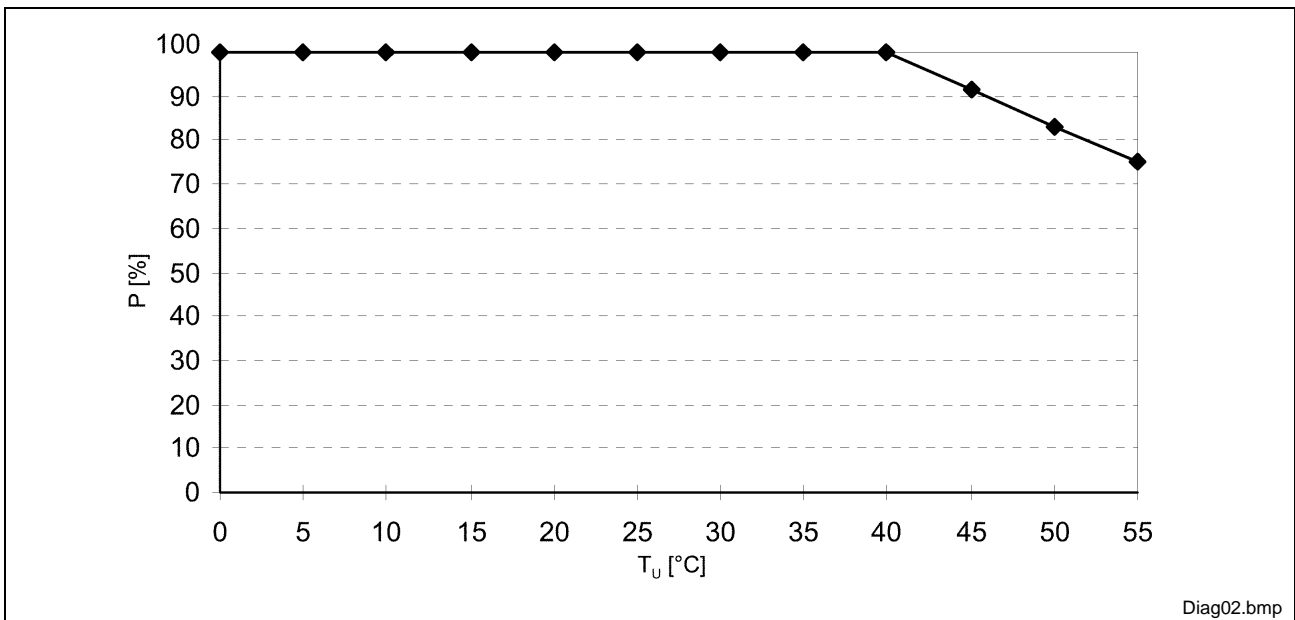

Fig. 4-27: Diagram of derating with a current load of no more than 4 A

**Legend** P [%] - Load capacity of the power supply unit of the logic and analog supply in %  
 T<sub>u</sub> [°C] - Ambient temperature in °C

## Power Loss

Formula for the calculation of electronics power loss:

$$P_{EL} = P_{BUS} + P_{PERI}$$

Fig. 4-28: Power loss P<sub>EL</sub> (formula 1)

$$P_{EL} = 2,6W + (1,1 \frac{W}{A} \times \sum_{n=0}^a I_{Ln}) + (0,7 \frac{W}{A} \times \sum_{m=0}^b I_{Lm})$$

Fig. 4-29: Power loss P<sub>EL</sub> (formula 2)

<b>With</b>	P <sub>EL</sub>	Total power loss in the terminal
	P <sub>BUS</sub>	Power loss for bus operation without peripheral load (constant)
	P <sub>PERI</sub>	Power loss with connected peripheral equipment
	I <sub>Ln</sub>	Current consumption of the device n from the logic supply
	n	Index over the number of connected devices (n = 1 to a)
	a	Number of connected devices (supply with logic voltage)
	$\sum_{n=0}^a$	Total current consumption of all devices from the 7.5 V logic supply (no more than 2 A)
	I <sub>Lm</sub>	Current consumption of the device m from the analog supply
	m	Index over the number of connected analog devices (n = 1 to b)
	b	Number of connected analog devices (supply with analog voltage)
	$\sum_{m=0}^b$	Total current consumption of all devices from the 24 V analog supply (no more than 0.5 A)

Substituting the maximum currents of 2 A (logic current) and 0.5 A (current for analog terminals) in the formula for calculation of the power loss with connected peripheral equipment results in:

$$P_{PERI} = 2.2 W + 0.35 W = 2.55 W$$

This value of 2.55 W corresponds to a load capacity of the power supply unit of 100% in the derating curves (see figures on page 4-7). It must be ensured that, at an ambient temperature of 40 °C, the rated load capacity specified in the derating curves is not exceeded. Of relevance here is the total load with connected peripheral equipment (P<sub>PERI</sub>), according to the formula. If, for instance, no current is consumed from the analog supply, the share of current from the logic supply can be higher.

Example:

Current load of the peripheral supply: 8 A

Ambient temperature: 55 °C

1. Rated load capacity of the logic and analog supply: 50% according to the graph

$$I_{LLogic} = 1 \text{ A}, I_{LAnalog} = 0.25 \text{ A}$$

$$P_{PERI} = 1.1 \text{ W} + 0.175 \text{ W}$$

$$P_{PERI} = 1.275 \text{ W (corresponds to 50 \% of 2.55 W)}$$

2. Potential logic current with the analog supply not loaded:

$$P_{PERI} = 1.1 \text{ W/A} \times I_{LLogic} + 0 \text{ W}$$

$$P_{PERI} / 1.1 \text{ W/A} = I_{LLogic}$$

$$I_{LLogic} = 1.275 \text{ W} / 1.1 \text{ W/A}$$

$$I_{LLogic} = 1.159 \text{ A}$$

## 5 Remote Bus Terminal R-IBS IL 24 RB-T

### 5.1 Description and Intended Use

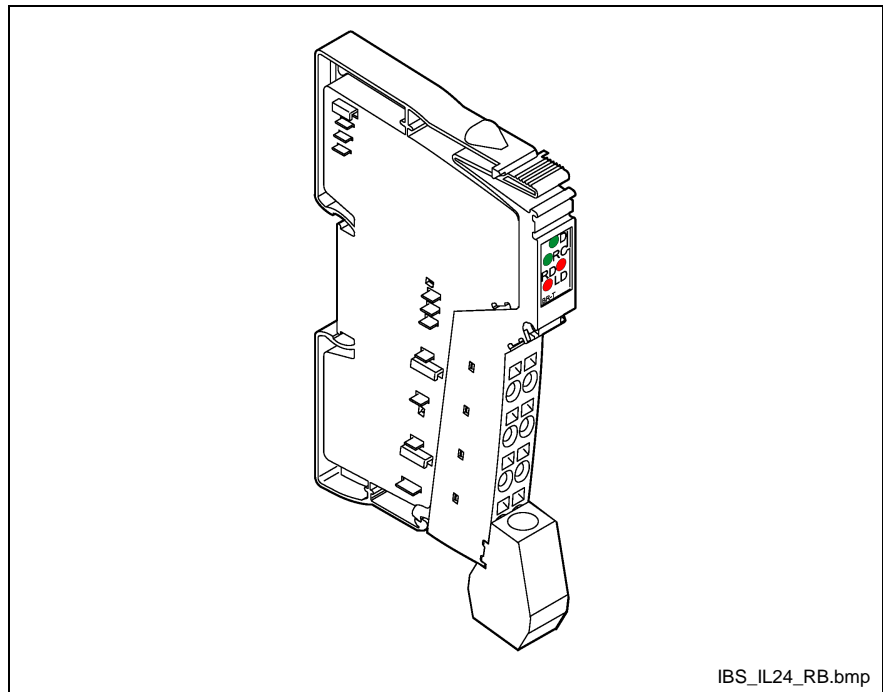

Fig. 5-1: Terminal R-IBS IL 24 RB-T with plugged-in connector

Using this terminal, a remote bus branch can be branched off from an Inline station. This allows integration of remote devices, such as indicator and button fields, motor switches with IP 65 degree of protection, or sensor/actuator boxes, into the INTERBUS via an Inline station.

### Features

- Copper connections for remote bus branch
- Supply of the remote bus branch terminal through the bus terminal

---

**Note:** The terminal for connection of a remote bus branch must be positioned directly behind a RECO Inline bus terminal. Only one remote bus branch terminal may be fitted within an Inline station.

---

## Indicator Elements

### Position of diagnostic indicators

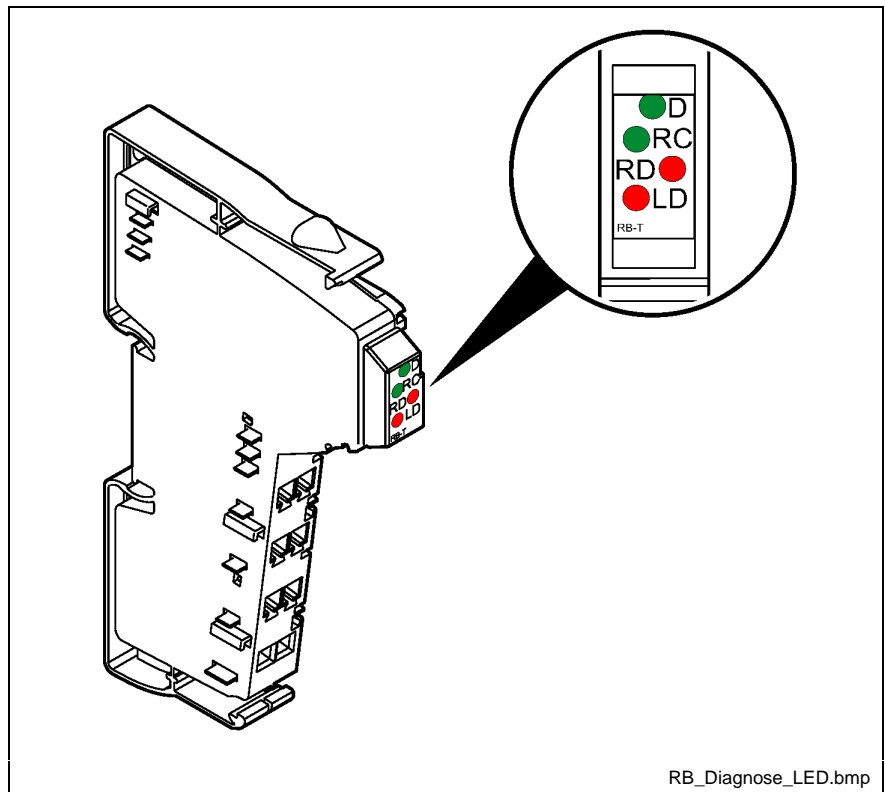

Fig. 5-2: Position of the diagnostic indicators of R-IBS IL24 RB-T

### Meaning of diagnostic indicators

Name	Color	Meaning
D	Green	Bus diagnostic
RC	Green	Remote bus cable check
RD	Red	Remote bus branch deactivated
LD	Red	Local bus deactivated

Fig. 5-3: Meaning of the diagnostic indicators of R-IBS IL 24 BK-T

## 5.2 Technical Data

### General Data

Housing dimensions	12.2 mm x 120 mm x 71.5 mm (W x H x D)	
Weight	45 g (without connectors)	
Permissible temperature	Operation Storage/transport	-25 °C up to +55 °C -25 °C up to +85 °C
Air humidity	Operation Storage/transport	75 % on average, 85 % occasionally 75 % on average, 85 % occasionally
Atmospheric pressure	Operation Storage/transport	80 kPa to 106 kPa (up to 2000 m above MSL) 76 kPa to 106 kPa (up to 3000 m above MSL)
Degree of protection	IP20 according to IEC 60529	
Safety classification	Classification 3, according to VDE 0106, IEC 60536	
Connection method	Via voltage routing	

Fig. 5-4: General technical data of R-IBS IL24 RB-T

### INTERBUS Interfaces

<b>Remote bus</b>	
Incoming remote bus	Via data routing
Outgoing remote bus	Via data routing
Remote bus branch	Copper line (RS-422), connected via an Inline shield connector; electrically isolated supply; shield directly connected to the functional earth ground.
Recommended cable lengths	

Fig. 5-5: Technical data of the R-IBS IL24 RB-T remote bus

<b>Local bus</b>		
Connection	Via data routing	
Level	5 V CMOS signal level	
Number of connectable Inline terminals	Limited by software	Max. 63
	Limited by power supply unit	Max. logic current consumption of the connected local bus modules: $I_{Max} \leq 2 \text{ A DC}$

Fig. 5-6: Technical data of the R-IBS IL24 RB-T local bus

**Note: Observe the current consumption of the modules!**

When projecting an Inline station, the logic current consumption of each device must be observed! The respective value is specified in each module-specific data sheet. It can be different for the various modules. Accordingly, the potential number of devices that can be connected depends on the specific setup of the station in question.

## 5.3 Connections

### Position of Terminals

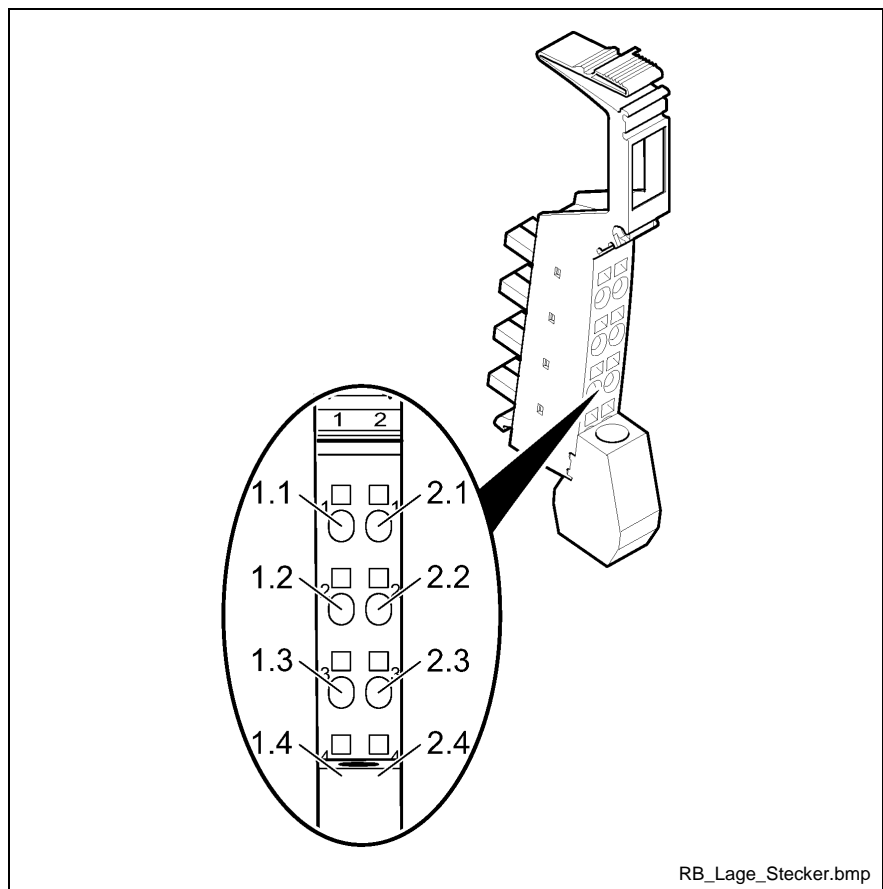

Fig. 5-7: Position of the R-IBS IL24 RB-T terminals

### Terminal Assignment

Terminal	Signal	Remark
1.1	/DO	Receive
2.1	DO	Receive
1.2	/DI	Send
2.2	DI	Send
1.3	GND	Reference potential
2.3	N.C.	
1.4	Shield	The shield potential is connected directly to the FE functional earth ground of the voltage jumper.
2.4	Shield	

Fig. 5-8: Terminal assignment of R-IBS IL24 RB-T

### Internal Block Diagram

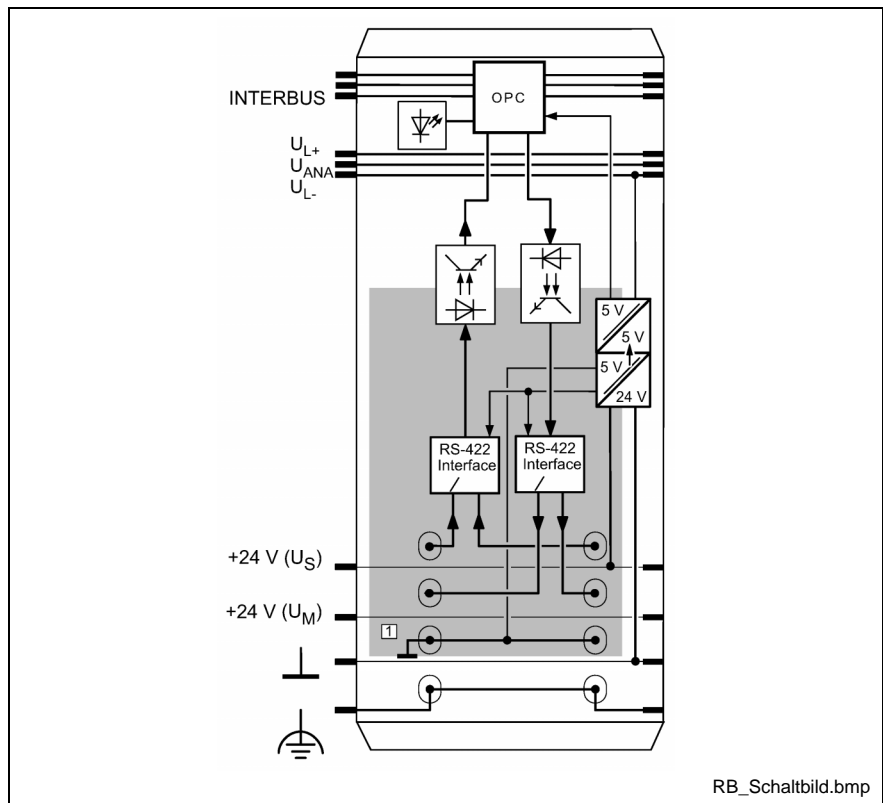

Fig. 5-9: Internal wiring of the terminal points of R-IBS IL24 RB-T

### Definition of symbols

Symbol	Definition
	Protocol chip (bus logic including voltage treatment)
	LED
	Optocoupler
	Galvanically isolated power supply unit
	F-GND reference potential (incoming interface)
	Interface module
	Electrically isolated area

Fig. 5-10: Definition of symbols

### Connection Example

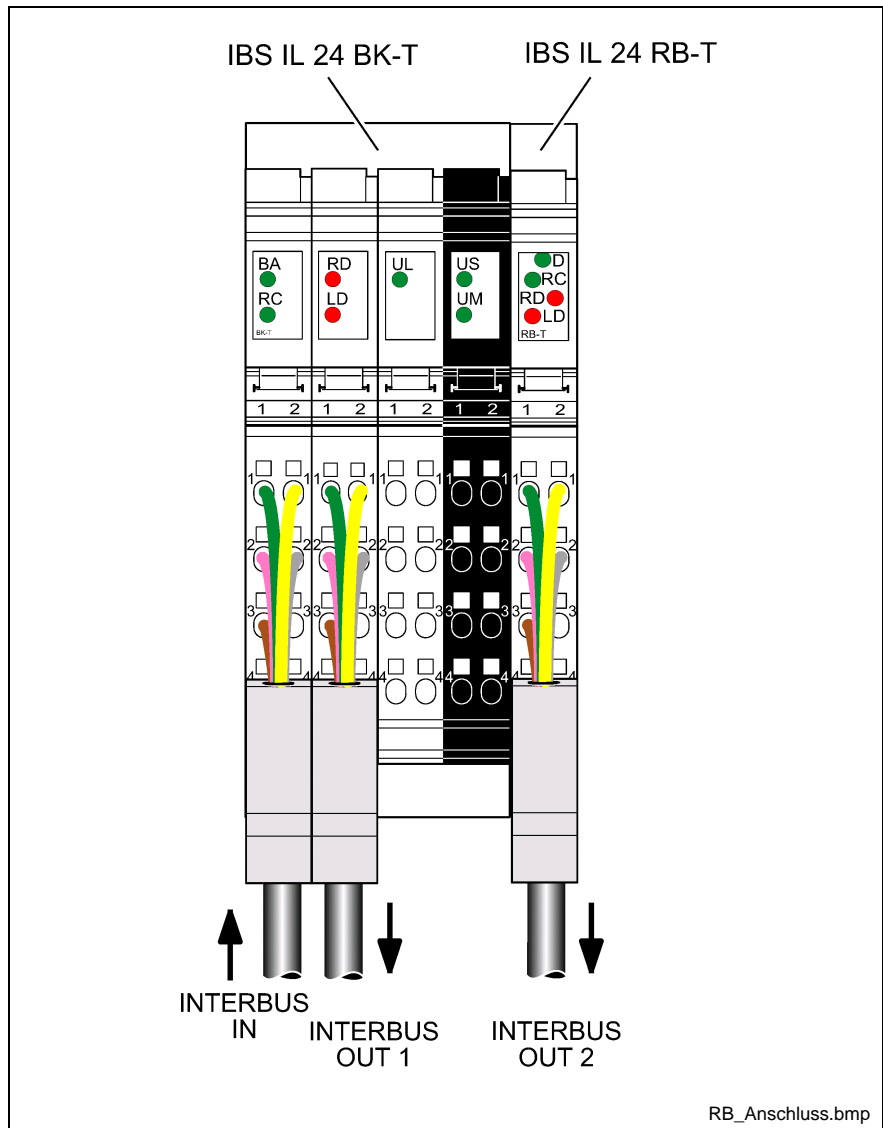

Fig. 5-11: Example of INTERBUS line connection

- INTERBUS IN Incoming remote bus
- INTERBUS OUT 1 Outgoing remote bus
- INTERBUS OUT 2 Remote bus branch

### Programming Data

ID code	04 <sub>hex</sub> (04 <sub>dec</sub> )
Length code	00 <sub>hex</sub>
Input address space	0 bytes
Output address space	0 bytes
Parameter channel (PCP)	0 bytes
Register length (bus)	0 bytes

Fig. 5-12: Programming data of R-IBS IL 24 RB-T

## 5.4 Electric Isolation

### Potentials of the Terminal

#### Common potentials

The 7.5 V logic supply, the 24 V analog supply, the 24 V bus terminal supply, and the 5 V logic supply of the remote bus branch terminal are applied to one potential.

#### Isolated potentials

The ground of the logic supply is connected to the ground of the 7.5 V logic supply of the bus terminal power supply unit. The interface supply for the remote bus branch is galvanically isolated from all other potentials. The peripheral supply is always galvanically isolated from the interface supply voltages.

### Potentials in Case of Combined Terminals

The table below shows the electric isolation or isolation of voltage ranges if the R-IBS IL 24 BK-T bus terminal and the R-IBS IL 24 RB-T remote bus branch terminal are used in combination:

#### Test section

5 V supply of incoming / outgoing remote bus electrically isolated from	
5 V supply of outgoing remote bus	500 V AC, 50 Hz, 1 min.
5 V supply of remote bus branch	
7.5 V logic supply, 24 V analog supply, 24 V bus terminal supply, 5 V logic supply of remote bus branch terminal	
24 V main supply / 24 V segment supply	
Functional earth ground	

Fig. 5-13: Potentials of R-IBS IL 24 RB-T in case of combined terminals

## 5.5 Diagrams and Formulas

### Power Loss

Formula for the calculation of electronics power loss:

$$P_{EL} = U_S \times I_{GES}$$

Fig. 5-14: Power loss P<sub>EL</sub> of the R-IBS IL 24 RB-T terminal

#### Housing power loss

P<sub>GEH</sub> = 0.7 W within the entire permissible range of ambient temperature

<b>With</b>	P <sub>EL</sub>	Total power loss in the terminal
	U <sub>S</sub>	Segment voltage
	I <sub>GES</sub>	Total current consumption in the remote bus branch terminal at U <sub>S</sub>
	P <sub>GEH</sub>	Permissible housing power loss



## 6 Power Terminal R-IB IL PWR IN

### 6.1 Description and Intended Use

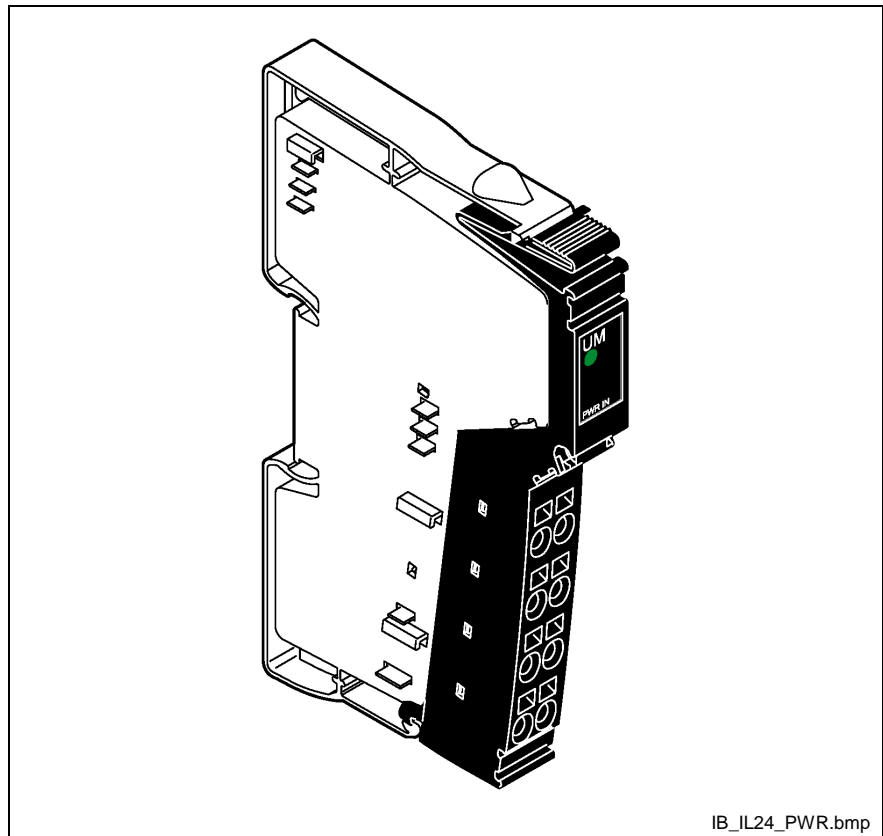

Fig. 6-1: R-IB IL 24 PWR IN terminal with plugged-in connector

The terminal permits feeding of supply voltages into the main circuit. In addition, the supply for a segment circuit can be made available at this terminal.

### Features

- The main voltage is fed in
- The segment voltage is fed in / made available.
- The main circuit is protected by means of an external fuse.
- The segment circuit can be protected by means of an external fuse.
- Diagnostic indicator.

---

**Note:** Since it is not provided with a protocol chip, this terminal is no bus device.

---

## Indicator Elements

### Position of diagnostic indicators

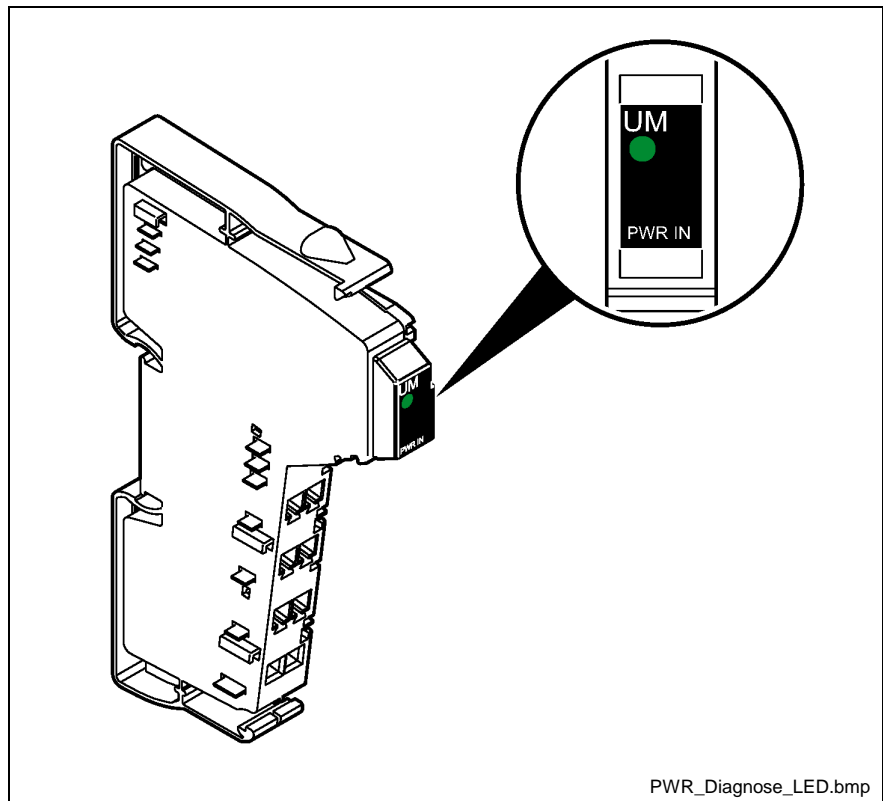

Fig. 6-2: Position of the diagnostic indicator of R-IB IL 24 PWR IN

### Meaning of diagnostic indicators

Name	Color	Meaning
UM	Green	24 V voltage (in the main circuit $U_M$ )

Fig. 6-3: Meaning of the diagnostic indicator of R-IB IL 24 PWR IN

## 6.2 Technical Data

General Notes		
Housing dimensions	12.2 mm x 120 mm x 71.5 mm (W x H x D)	
Weight	44 g (without connectors)	
Permissible temperature	Operation Storage/transport	-25 °C up to +55 °C -25 °C up to +85 °C
Air humidity	Operation Storage/transport	5% up to 90%, moisture condensation is not allowed 5% up to 95%, moisture condensation is not allowed
Atmospheric pressure	Operation Storage/transport	80 kPa to 106 kPa (up to 2000 m above MSL) 70 kPa to 106 kPa (up to 3000 m above MSL)
Degree of protection	IP20 according to IEC 60529	
Safety classification	Classification 3, according to VDE 0106, IEC 60536	

Fig. 6-4: General technical data of R-IB IL 24 PWR IN

24 V peripheral supply		
Connection	+ 24 V Ground	Terminal points 1.2 and 2.2 Terminal points 1.3 and 2.3
Rated value	24 V DC	
Tolerance	-15 % / +20 % (according to EN 61131-2)	
AC voltage component	5 %	
Permissible range	19.2 V to 30 V (including ripple factor)	
Permissible current	Max. 8 A	
Requirements for the voltage supply	If it is intended to set up an electrically isolated range, the power terminals must be supplied from a new power supply unit. The 24 V range must be protected by means of an external fuse.	

Fig. 6-5: Data of the 24 V peripheral supply

---

**Note:** The power supply unit must be able to deliver the quadruple rated current of the external fuse.

---

Safety equipment	
Overload/short-circuit in the segment circuit	No
Overvoltage	Yes Suppressor diode for voltage limitation between the terminal points 1.1 and 1.3 as well as between the terminal points 1.2 and 1.3.
Polarity reversal	Yes

Fig. 6-6: Safety equipment of R-IB IL 24 PWR IN

---

**Note:** The power supply unit must be able to deliver the quadruple rated current of the external fuse.

---

## 6.3 Connections

### Position of Terminals

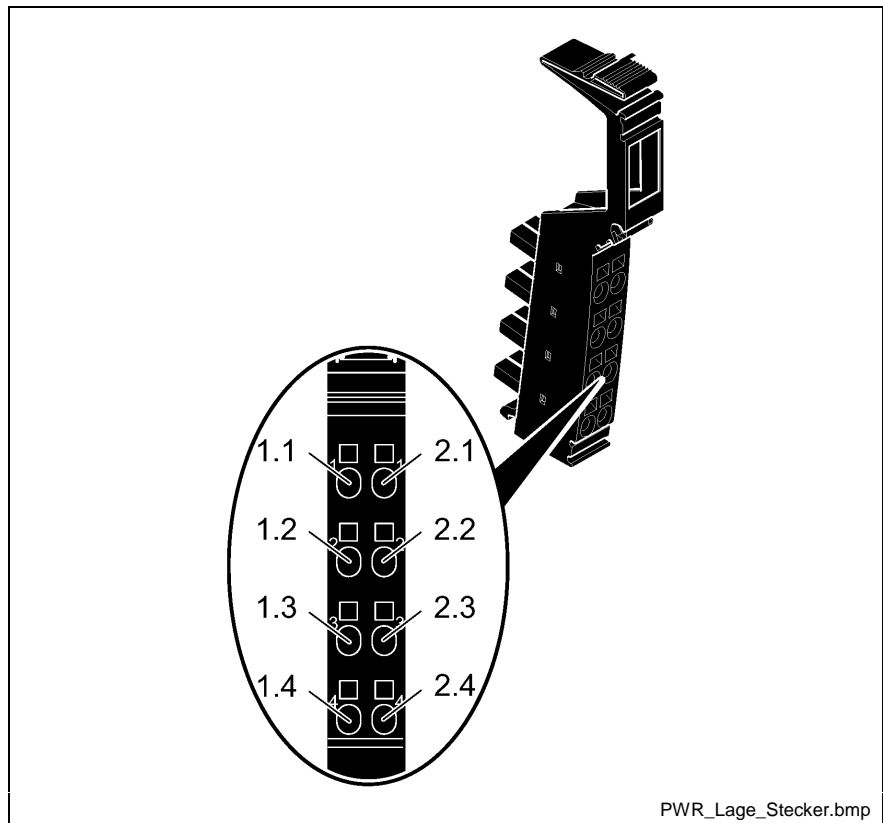

Fig. 6-7: Position of the R-IB IL 24 PWR IN terminals

### Terminal Assignment

Terminal point	Assignment
1.1, 2.1	Supply point for the segment circuit $U_S$ (+24 V); connection of a switch or a jumper in the segmentation level
1.2, 2.2	Supply points for the main circuit $U_M$ (main circuit; +24 V). Connection of a switch or a jumper in the segmentation level These terminal points are connected to each other and, on one side, to the voltage jumper of the unprotected main supply $U_M$ . Together, the voltage jumpers of the unprotected main circuit $U_M$ and the segment circuit $U_S$ are provided with a load capacity of 8 A.
1.3, 2.3	Ground connection (GND) The reference potential is directly transmitted to the voltage jumper and is also provided as the ground reference for the peripheral and the segment voltages.
1.4, 2.4	FE connection The contacts are directly connected to the voltage jumper and to the FE spring on the housing bottom. When latched onto a grounded mounting rail, the terminal is grounded.
	The terminal points 1.1, 1.2, and 1.3 are connected capacitively to FE.

Fig. 6-8: Terminal assignment of R-IB IL PWR IN

**Note:** The maximum total load capacity through the voltage jumpers is 8 A.

### Internal Block Diagram

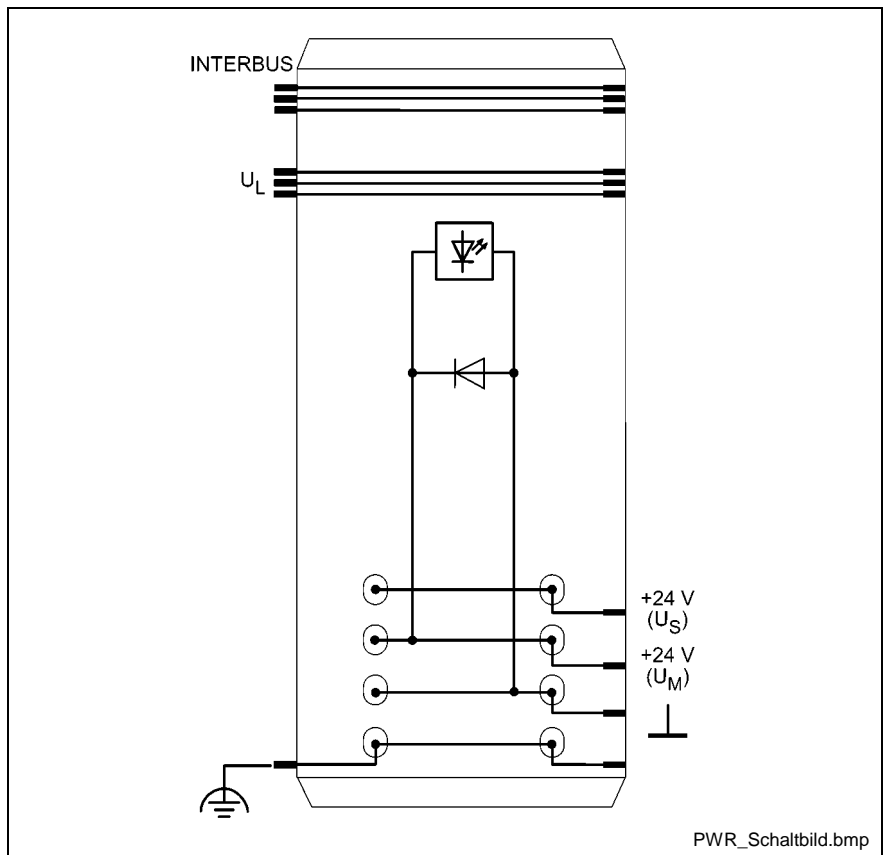

Fig. 6-9: Internal wiring of the terminal points of R-IB IL 24 PWR IN

### Definition of symbols



Symbol	Definition
	LED
	Diode

Fig. 6-10: Definition of symbols

## Connection Example

**Note:** The 24 V supply must be protected by means of an external fuse!

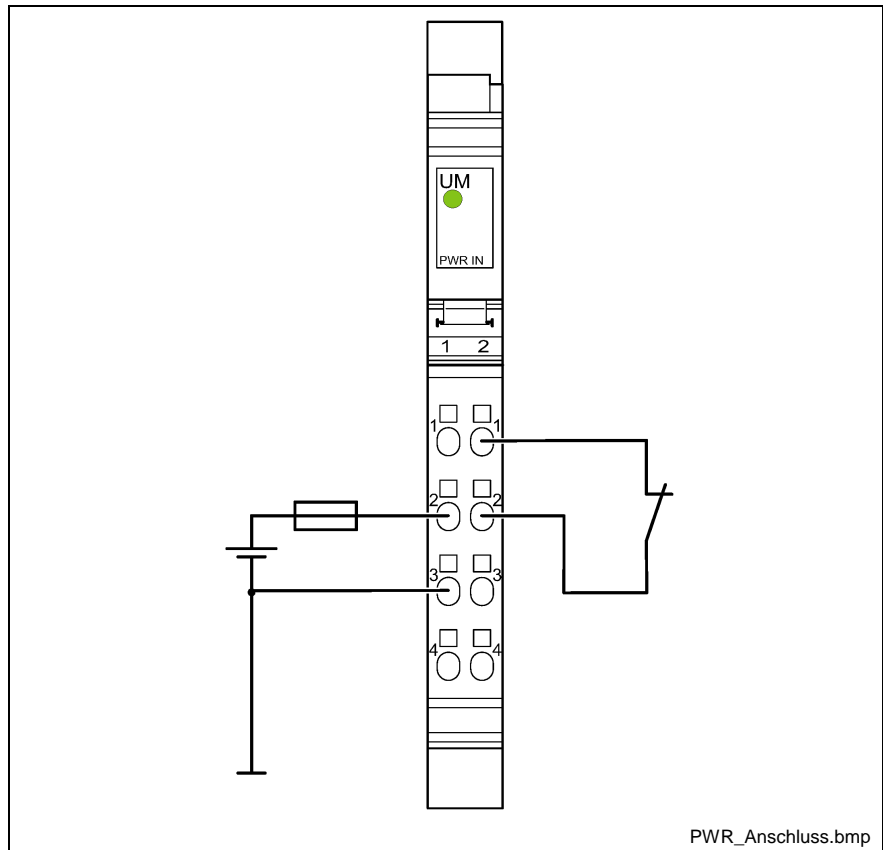

Fig. 6-11: Connection of the supply voltage and of an external switch

**Note:** The switch can be used to establish a switched segment circuit.

If this is not required in a specific application, the segment voltage can be made available in one of the following ways:

1. Fit a jumper across the connectors 1.1 (2.1) and 1.2 (2.2).
2. Feed in the segment voltage separately.
3. Use an additional segment terminal.

## 6.4 Electric Isolation

---

**Note:** To provide electric isolation of the logic level from the peripheral range, these ranges must be supplied from separate power supply units either via the bus terminal or via the bus terminal and a power terminal. It is not permitted to connect the supply units in the 24 V range. Observe the GND-PE connections at the supply units!

---

### Common potentials

The 24 V main voltage, the 24 V segment voltage, and GND are applied to the same potential. FE is a separate potential range.

### Isolated potentials

The table below shows the potentials in case of a combination of bus terminal, power terminal, and I/O terminal.

Test section	Test voltage
5 V supply of incoming remote bus / 7.5 V supply (bus logic)	500 V AC, 50 Hz, 1 min.
5 V supply of outgoing remote bus / 7.5 V supply (bus logic)	
7.5 V supply (bus logic) / 24 V supply (peripheral equipment)	
24 V supply (peripheral equipment) / functional earth ground	

Fig. 6-12: Test section of R-IB IL 24 PWR IN / R-IB IL 24 SEG/F



## 7 Segment Terminal

### 7.1 Description and Intended Use

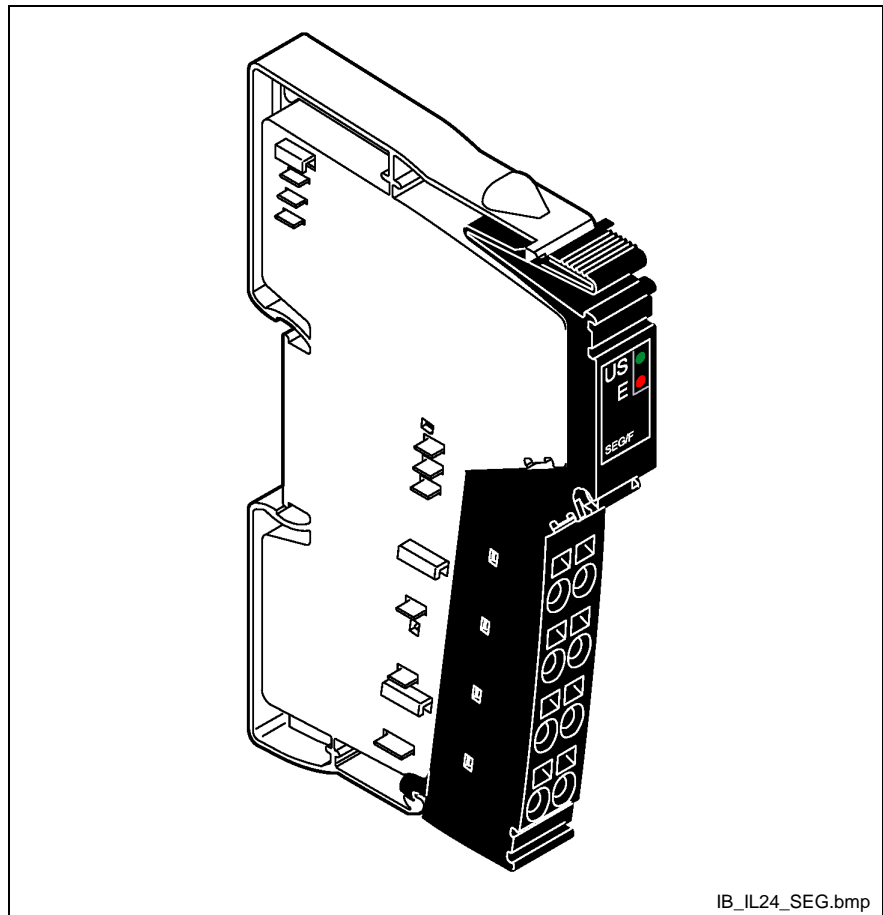

Fig. 7-1: R-IB IL 24 SEG/F terminal with plugged-in connector

The terminal permits setting up of a protected partial circuit (segment circuit) within the main circuit. It is not provided for voltage supply. For that reason, it does not contain any elements protecting against polarity reversal and overvoltage.

### Features

- Automatic setup of a partial circuit within the main circuit
- Protection of the segment circuit by means of an internal fuse
- Diagnostic indicator

---

**Note:** Since it is not provided with a protocol chip, this terminal is no bus device.

---

## Indicator Elements

### Position of diagnostic indicators

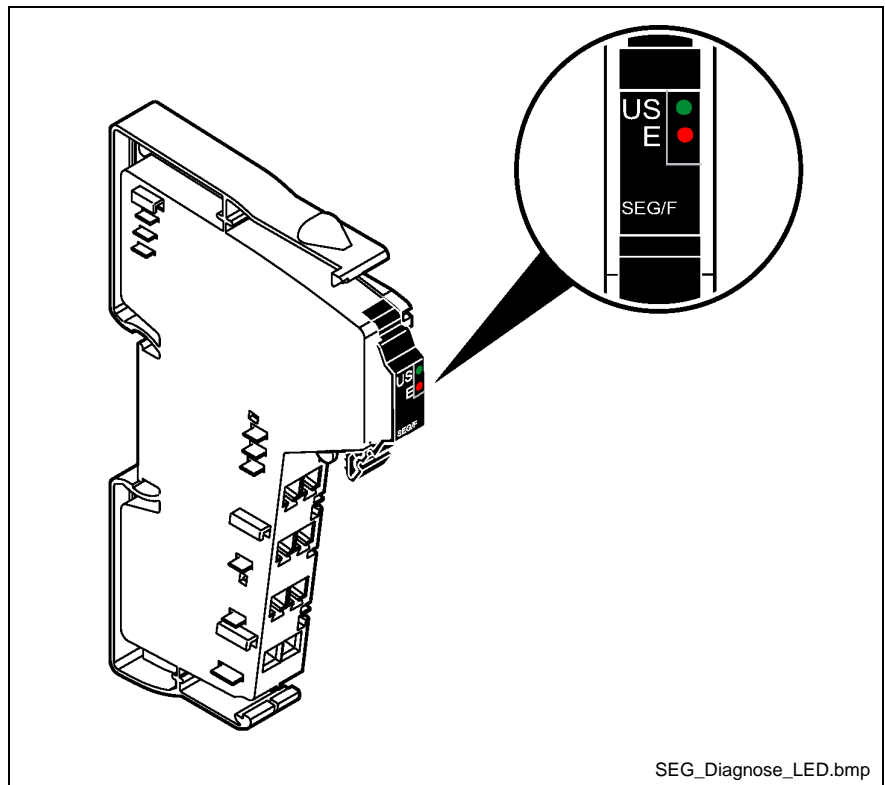

Fig. 7-2: Position of the diagnostic indicators of R-IB IL 24 SEG/F

### Meaning of diagnostic indicators

Name	Color	Meaning
US	Green	24 V voltage (in the segment circuit $U_S$ ; before the fuse)
E	Red	Fuse of the segment terminal (in the segment circuit $U_S$ )

Fig. 7-3: Meaning of diagnostic indicators

## 7.2 Technical Data

General Notes		
Housing dimensions	12.2 mm x 120 mm x 71.5 mm (W x H x D)	
Weight	44 g (without connectors)	
Permissible temperature	Operation Storage/transport	-25 °C up to +55 °C -25 °C up to +85 °C
Air humidity	Operation Storage/transport	5% up to 90%, no moisture condensation 5% up to 90%, no moisture condensation
Atmospheric pressure	Operation Storage/transport	80 kPa to 106 kPa (up to 2000 m above MSL) 70 kPa to 106 kPa (up to 3000 m above MSL)
Degree of protection	IP20 according to IEC 60529	
Safety classification	Classification 3, according to VDE 0106, IEC 60536	

Fig. 7-4: General technical data of R-IB IL 24 SEG/F

**Note:** The voltage is supplied in the bus terminal or the power terminal. The segment terminal does not have to be provided with connectors for the supply voltage. The appropriate terminals are available for test purposes.

Permissible total current in the voltage jumpers of the main and the segment circuits	
Rated current of the terminal	6.0 A
Max. permissible value	8.0 A

Fig. 7-5: Permissible total current

**Note:** Upon delivery, the terminal is provided with a slow-blow 6.3-A fusible cutout. If higher transverse currents are incurred, the user is responsible for providing a higher-rated fuse.

Safety equipment	
Overload/short-circuit in the segment circuit	Slow-blow 6.3-A fusible cutout 5 x 20
Overvoltage	Safety elements in the power terminal or the bus terminal
Polarity reversal	Safety elements in the power terminal or the bus terminal

Fig. 7-6: Safety equipment

**Note:** With a rating higher than 2 A, only slow-blow fuses may be used!

## 7.3 Connections

### Position of Terminals

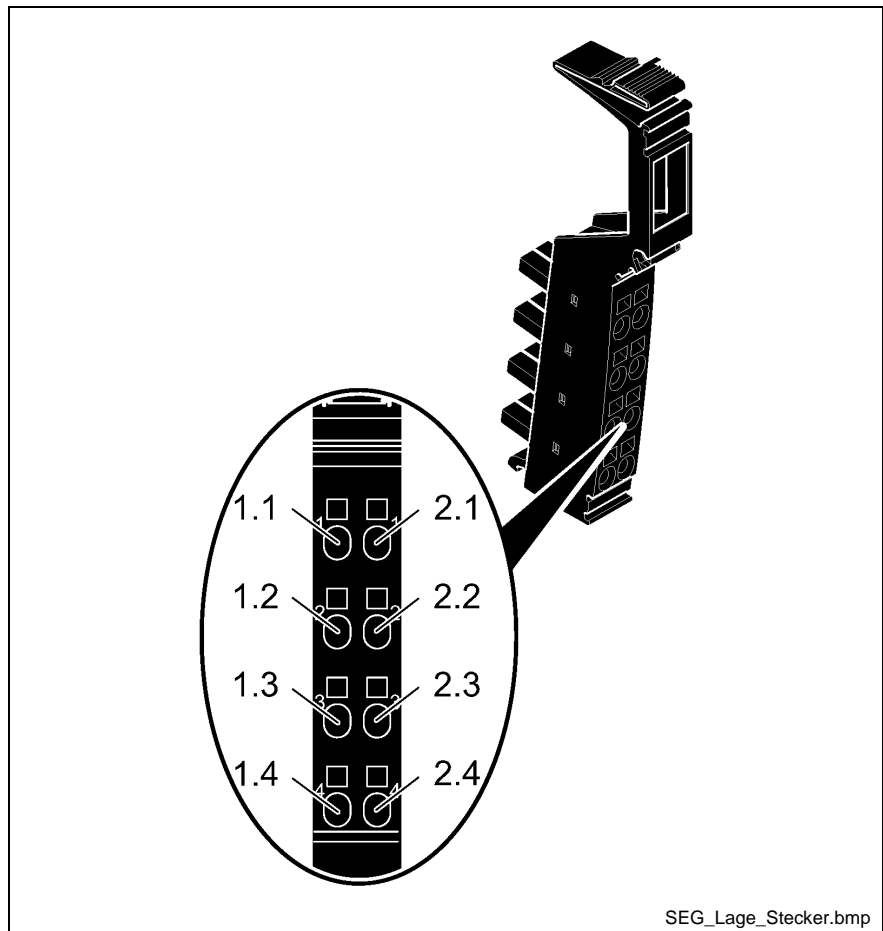

Fig. 7-7: Position of the R-IB IL SEG/F terminals

### Terminal Assignment

Terminal	Signal
1.1, 2.1	Segment voltage $U_S$ (after the fuse)
1.2, 2.2	Main voltage $U_M$
1.3, 2.3	GND of supply voltages
1.4, 2.4	FE connection

Fig. 7-8: Terminal assignment

### Internal Block Diagram

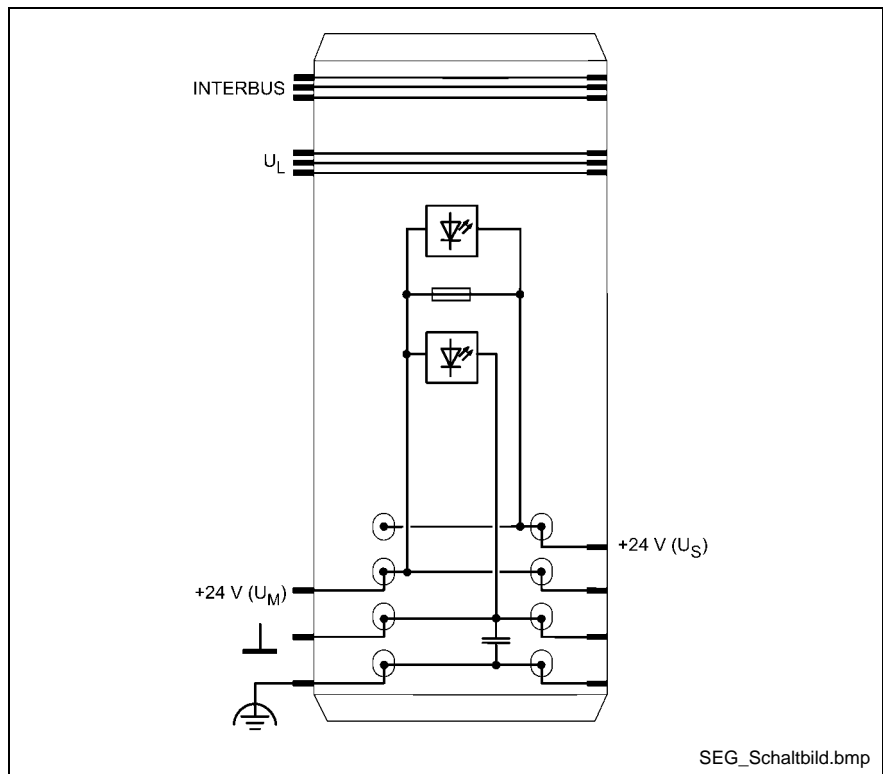

Fig. 7-9: Internal wiring of terminal points

### Definition of symbols

Symbol	Definition
	LED
	Fuse
	Capacitive connection to the functional earth ground (FE)

Fig. 7-10: Definition of symbols

## 7.4 Electric Isolation

---

**Note:** To provide electric isolation of the logic level from the peripheral range, these ranges must be supplied from separate power supply units either via the bus terminal or via the bus terminal and a power terminal. It is not permitted to connect the supply units in the 24 V range. Observe the GND-PE connections at the supply units!

---

### Common potentials

The 24 V main voltage, the 24 V segment voltage, and GND are applied to the same potential. FE is a separate potential range.

### Isolated potentials

The table below shows the potentials in case of a combination of bus terminal, power terminal, and I/O terminal.

Test section	Test voltage
5 V supply of incoming remote bus / 7.5 V supply (bus logic)	500 V AC, 50 Hz, 1 min.
5 V supply of outgoing remote bus / 7.5 V supply (bus logic)	
7.5 V supply (bus logic) / 24 V supply (peripheral equipment)	
24 V supply (peripheral equipment) / functional earth ground	

Fig. 7-11: Test section of R-IB IL 24 PWR IN / R-IB IL 24 SEG/F

## 7.5 Diagrams and Formulas

### Derating

#### Load current in the segment circuit

Ambient temperature	Load current in the segment circuit $I_S$
55 °C	4.0 A
45 °C	6.3 A

Fig. 7-12: Derating of the load current in the segment circuit

#### Load current in relation to the ambient temperature

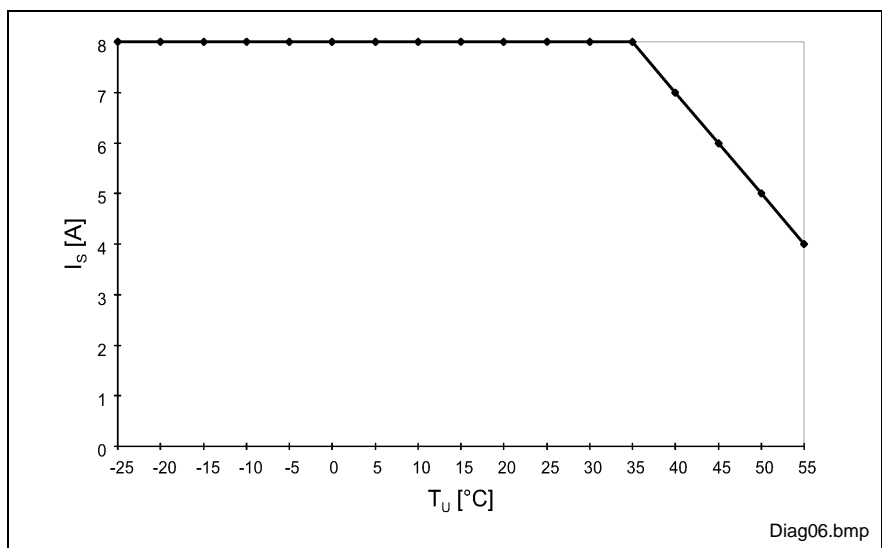

Fig. 7-13: Load current in relation to the ambient temperature

$I_S$  [A]                      Load current in the segment circuit in A  
 $T_U$  [°C]                      Ambient temperature in °C

### Voltage Characteristics in the Segment Circuit with a Defective Use

**Note:** Even if the fusible cutout has tripped, the segment circuit is still live! Observe the characteristic curve!

Resistance ( $\Omega$ )	Typical output voltage (V)	Typical current (mA)
1000000	12.80	0.013
100000	12.21	0.122
10000	8.60	0.86
1000	1.99	1.99
100	0.28	2.8

Fig. 7-14: Characteristic voltage and current data in relation to the resistance

### Output voltage in relation to the resistance

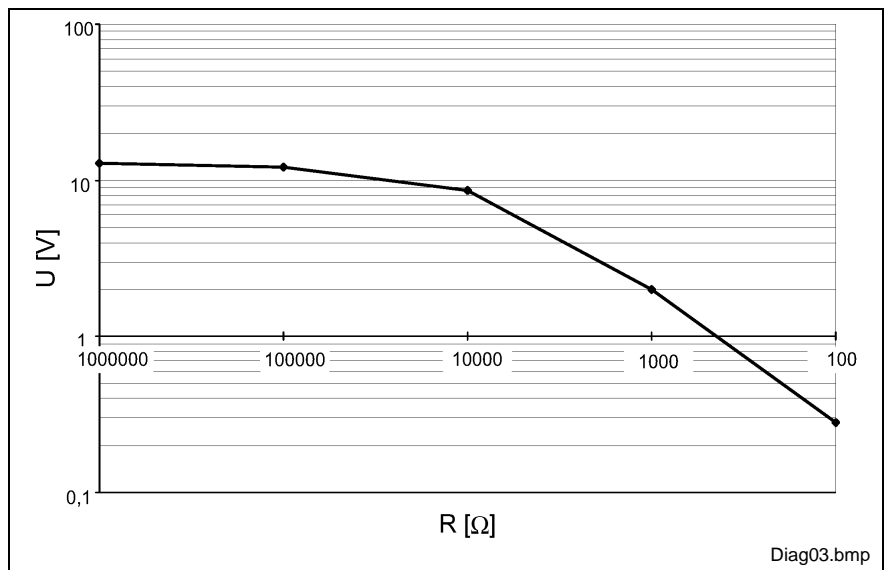

Fig. 7-15: Output voltage in relation to the resistance

U [V] Output voltage in V

R [Ω] Resistance in Ω

### Output current in relation to the resistance

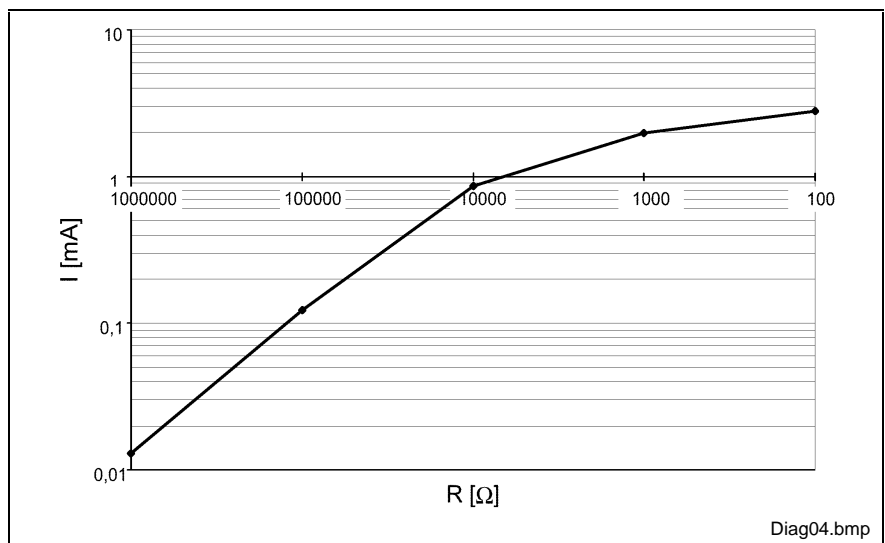

Fig. 7-16: Output current in relation to the resistance

I [A] Output current in A

R [Ω] Resistance in Ω

## Power Loss

Formula for the calculation of electronics power loss:

$$P_{EL} = 0,180W + I_S^2 \times R_F$$

Fig. 7-17: Power loss P<sub>EL</sub> of the R-IB IL 24 SEG/F terminal

### Power loss of the housing in relation to the ambient temperature

$$P_{GEH} = 2,4W \quad \text{at } -25^\circ C < T_U \leq -5^\circ C$$

Fig. 7-18: Housing power loss in range 1

$$P_{GES} = 2,4W - \frac{T_U - (-5^\circ C)}{37,5K/W} \quad \text{at } -5^\circ C < T_U \leq +55^\circ C$$

Fig. 7-19: Housing power loss in range 2

- With**
- P<sub>EL</sub> Total power loss in the terminal
  - I<sub>S</sub> Load current in the segment circuit
  - R<sub>F</sub> Resistance of the fuse; the resistance of the fuse R<sub>F</sub> for a 6.3 AT fuse is approx. 50 mΩ.
  - T<sub>U</sub> Ambient temperature

### Typical power loss in relation to the load current in the segment circuit

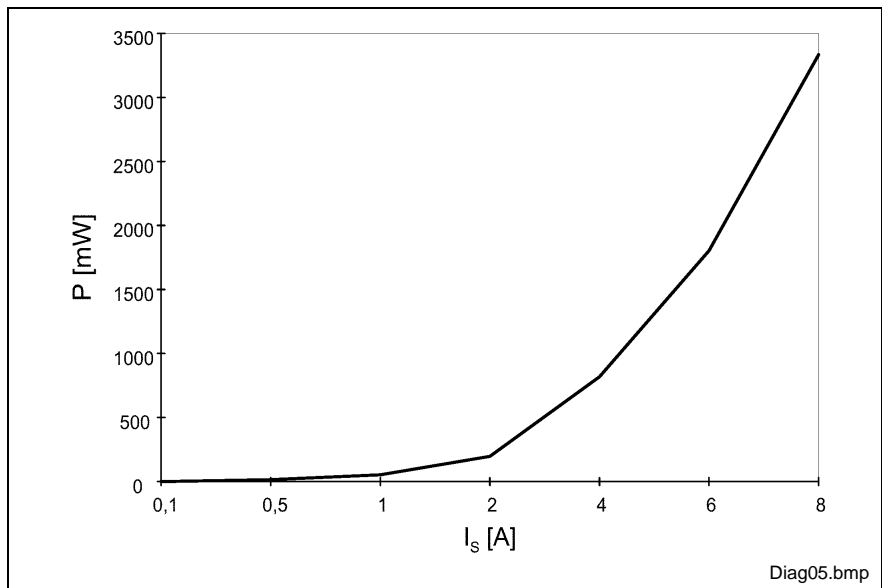

Fig. 7-20: Typical power loss in relation to the load current

- P [mW] Power loss in mW
- I<sub>S</sub> [A] Load current in the segment circuit in A



## 8 Ordering Information

### 8.1 Ordering Names

**Note:** The connectors are not included in the scope of supply of any of the modules. They must be ordered separately.

Description	Short type (ordering name)	Material number
INTERBUS Inline bus terminal	R-IBS IL 24 BK-T	289280
Connector set with all required connectors	R-IB IL BK-PLSET	289338
INTEBUS Inline remote bus branch	R-IBS IL 24 RB-T	289282
Shield connector Packing contents: 5 pieces	R-IB IL SCN-6 SHIELD	289331
Power terminal without fuse	R-IB IL 24 PWR IN	289312
Segment terminal with fuse	R-IB IL 24 SEG/F	289313
Slow-blow 6.3 A fuse	SICHERUNG-F 6,300A 19195 TRAEGE	251957
Connector for voltage supply (black, printed) Packing contents: 10 pieces	R-IB IL SCN-PWR IN-CP	289328
Application description	DOK-CONTRL-R-IL*IBSSYS	289594

Fig. 8-1: Ordering names of terminals and accessories



## 9 List of Figures

- Fig. 1-1: Remote bus terminals and supply modules 1-1
- Fig. 3-1: Hazard classification (according to ANSI Z535) 3-1
- Fig. 4-1: Terminal R-IBS IL 24 BK-T with fitted connectors and end plate 4-1
- Fig. 4-2: Position of the diagnostic indicators of R-IBS IL 24 BK-T 4-2
- Fig. 4-3: Meaning of the diagnostic indicators of R-IBS IL 24 BK-T 4-2
- Fig. 4-4: General technical data of R-IBS IL 24 BK-T 4-3
- Fig. 4-5: Technical data of the remote bus R-IBS IL 24 BK-T 4-3
- Fig. 4-6: Technical data of the local bus R-IBS IL 24 BK-T 4-3
- Fig. 4-7: Functional technical data of R-IBS IL 24 BK-T 4-4
- Fig. 4-8: 24 V main supply / 24 V segment supply 4-4
- Fig. 4-9: 24 V bus terminal supply 4-5
- Fig. 4-10: 24 V module supply 4-6
- Fig. 4-11: Safety equipment of R-IBS IL 24 BK-T 4-6
- Fig. 4-12: Position of the R-IBS IL 24 BK-T terminals 4-7
- Fig. 4-13: Terminal assignment of connector 1 4-7
- Fig. 4-14: Terminal assignment of connector 2 4-8
- Fig. 4-15: Terminal assignment of connector 3 4-8
- Fig. 4-16: Terminal assignment of connector 4 4-8
- Fig. 4-17: Internal wiring of the terminal points of R-IBS IL 24 BK-T 4-11
- Fig. 4-18: Definition of symbols 4-11
- Fig. 4-19: Example of line connection to the bus terminal 4-12
- Fig. 4-20: Color coding of connector 1 4-12
- Fig. 4-21: Programming data of R-IBS IL 24 BK-T 4-13
- Fig. 4-22: Electric isolation of the various functional areas 4-14
- Fig. 4-23: Common potentials of R-IBS IL 24 BK-T 4-14
- Fig. 4-24: Isolated potentials of R-IBS IL 24 BK-T 4-15
- Fig. 4-25: Test section of R-IBS IL 24 BK-T 4-15
- Fig. 4-26: Diagram of derating with a current load of no more than 8 A 4-16
- Fig. 4-27: Diagram of derating with a current load of no more than 4 A 4-16
- Fig. 4-28: Power loss  $P_{EL}$  (formula 1) 4-17
- Fig. 4-29: Power loss  $P_{EL}$  (formula 2) 4-17
- Fig. 5-1: Terminal R-IBS IL 24 RB-T with plugged-in connector 5-1
- Fig. 5-2: Position of the diagnostic indicators of R-IBS IL24 RB-T 5-2
- Fig. 5-3: Meaning of the diagnostic indicators of R-IBS IL 24 BK-T 5-2
- Fig. 5-4: General technical data of R-IBS IL24 RB-T 5-3
- Fig. 5-5: Technical data of the R-IBS IL24 RB-T remote bus 5-3
- Fig. 5-6: Technical data of the R-IBS IL24 RB-T local bus 5-3
- Fig. 5-7: Position of the R-IBS IL24 RB-T terminals 5-4
- Fig. 5-8: Terminal assignment of R-IBS IL24 RB-T 5-4
- Fig. 5-9: Internal wiring of the terminal points of R-IBS IL24 RB-T 5-5

- Fig. 5-10: Definition of symbols 5-5
- Fig. 5-11: Example of INTERBUS line connection 5-6
- Fig. 5-12: Programming data of R-IBS IL 24 RB-T 5-6
- Fig. 5-13: Potentials of R-IBS IL 24 RB-T in case of combined terminals 5-7
- Fig. 5-14: Power loss  $P_{EL}$  of the R-IBS IL 24 RB-T terminal 5-7
- Fig. 6-1: R-IB IL 24 PWR IN terminal with plugged-in connector 6-1
- Fig. 6-2: Position of the diagnostic indicator of R-IB IL 24 PWR IN 6-2
- Fig. 6-3: Meaning of the diagnostic indicator of R-IB IL 24 PWR IN 6-2
- Fig. 6-4: General technical data of R-IB IL 24 PWR IN 6-3
- Fig. 6-5: Data of the 24 V peripheral supply 6-3
- Fig. 6-6: Safety equipment of R-IB IL 24 PWR IN 6-3
- Fig. 6-7: Position of the R-IB IL 24 PWR IN terminals 6-4
- Fig. 6-8: Terminal assignment of R-IB IL PWR IN 6-4
- Fig. 6-9: Internal wiring of the terminal points of R-IB IL 24 PWR IN 6-5
- Fig. 6-10: Definition of symbols 6-5
- Fig. 6-11: Connection of the supply voltage and of an external switch 6-6
- Fig. 6-12: Test section of R-IB IL 24 PWR IN / R-IB IL 24 SEG/F 6-7
- Fig. 7-1: R-IB IL 24 SEG/F terminal with plugged-in connector 7-1
- Fig. 7-2: Position of the diagnostic indicators of R-IB IL 24 SEG/F 7-2
- Fig. 7-3: Meaning of diagnostic indicators 7-2
- Fig. 7-4: General technical data of R-IB IL 24 SEG/F 7-3
- Fig. 7-5: Permissible total current 7-3
- Fig. 7-6: Safety equipment 7-3
- Fig. 7-7: Position of the R-IB IL SEG/F terminals 7-4
- Fig. 7-8: Terminal assignment 7-4
- Fig. 7-9: Internal wiring of terminal points 7-5
- Fig. 7-10: Definition of symbols 7-5
- Fig. 7-11: Test section of R-IB IL 24 PWR IN / R-IB IL 24 SEG/F 7-6
- Fig. 7-12: Derating of the load current in the segment circuit 7-7
- Fig. 7-13: Load current in relation to the ambient temperature 7-7
- Fig. 7-14: Characteristic voltage and current data in relation to the resistance 7-7
- Fig. 7-15: Output voltage in relation to the resistance 7-8
- Fig. 7-16: Output current in relation to the resistance 7-8
- Fig. 7-17: Power loss  $P_{EL}$  of the R-IB IL 24 SEG/F terminal 7-9
- Fig. 7-18: Housing power loss in range 1 7-9
- Fig. 7-19: Housing power loss in range 2 7-9
- Fig. 7-20: Typical power loss in relation to the load current 7-9
- Fig. 8-1: Ordering names of terminals and accessories 8-1

# 10 Index

## 2

24 V bus terminal supply 4-5, 4-10

24 V main supply 4-4, 4-10

24 V peripheral supply 6-3

24 V segment supply 4-4, 4-10

## A

Ambient temperature 4-16

Analog supply 4-6

Appropriate use

Area of application 2-2

Introduction 2-1

Uses 2-2

## C

Common potentials 4-14, 5-7, 6-7, 7-6

## D

Definition of symbols 4-11, 5-5, 6-5, 7-5

Derating 4-16, 7-7

Diagnostic indicator of R-IB IL 24 PWR IN 6-2

Diagnostic indicators of R-IB IL 24 SEG/F 7-2

Diagnostic indicators of R-IBS IL 24 BK-T 4-2

Diagnostic indicators of R-IBS IL24 RB-T 5-2

Diagrams 4-16

## E

Electric isolation 4-14

## F

Functional earth ground 4-8

## I

Inappropriate use 2-2

Consequences, Discharge of liability 2-1

Interface configuration 4-4

Internal wiring 4-11, 5-5, 6-5, 7-5

Isolated potentials 4-15, 5-7, 6-7, 7-6

## L

Load capacity of power supply unit 4-16

Load current 7-7

Logic supply 4-6

## M

Module supply 4-6

## O

Ordering names 8-1

Output current 7-8

Output voltage 7-8

**P**

Permissible total current 7-3  
Power loss 4-17, 5-7, 7-9  
Programming data of R-IBS IL 24 BK-T 4-13  
Programming data of R-IBS IL 24 RB-T 5-6

**R**

Reconfiguration pushbutton 4-4  
Reconfiguration request 4-4  
Remote bus branch 1-1, 5-1  
R-IB IL 24 PWR IN 6-1  
R-IB IL 24 SEG/F 7-1  
R-IBS IL 24 BK-T 1-1, 4-1  
R-IBS IL 24 RB-T 5-1

**S**

Safety equipment 7-3  
Safety equipment of R-IB IL 24 PWR IN 6-3  
Safety equipment of R-IBS IL 24 BK-T 4-6  
Safety Instructions for Electric Drives and Controls 3-1  
Segment circuit 1-2, 7-1  
Sensor/actuator boxes 1-1, 5-1  
Supply connector 4-8

**T**

Technical data of local bus 4-3, 5-3  
Technical data of remote bus 4-3, 5-3  
Technical data of R-IB IL 24 PWR IN 6-3  
Technical data of R-IB IL 24 SEG/F 7-3  
Technical data of R-IBS IL 24 BK-T 4-3  
Technical data of R-IBS IL24 RB-T 5-3  
Terminal assignment 4-7, 4-12  
Terminals of R-IB IL 24 PWR IN 6-4  
Terminals of R-IB IL SEG/F 7-4  
Terminals of R-IBS IL 24 BK-T 4-7  
Terminals of R-IBS IL24 RB-T 5-4  
Test section 5-7, 6-7, 7-6  
Test section of R-IBS IL 24 BK-T 4-15

**U**

Use *See appropriate use and inappropriate use*

**V**

Voltage characteristics 7-7  
Voltage jumper 4-6  
Voltage supply 4-4

# 11 Service & Support

## 11.1 Helpdesk

Unser Kundendienst-Helpdesk im Hauptwerk Lohr am Main steht Ihnen mit Rat und Tat zur Seite. Sie erreichen uns

- telefonisch: **+49 (0) 9352 40 50 60**  
über Service Call Entry Center Mo-Fr 07:00-18:00
- per Fax: **+49 (0) 9352 40 49 41**
- per e-Mail: **service@indramat.de**

Our service helpdesk at our headquarters in Lohr am Main, Germany can assist you in all kinds of inquiries. Contact us

- by phone: **+49 (0) 9352 40 50 60**  
via Service Call Entry Center Mo-Fr 7:00 am - 6:00 pm
- by fax: **+49 (0) 9352 40 49 41**
- by e-mail: **service@indramat.de**

## 11.2 Service-Hotline

Außerhalb der Helpdesk-Zeiten ist der Service direkt ansprechbar unter

**+49 (0) 171 333 88 26**  
oder **+49 (0) 172 660 04 06**

After helpdesk hours, contact our service department directly at

1. **+49 (0) 171 333 88 26**
- or **+49 (0) 172 660 04 06**

## 11.3 Internet

Ergänzende Hinweise zu Service, Reparatur und Training sowie die **aktuellen** Adressen unserer Service- und Vertriebsbüros finden Sie unter **www.indramat.de** – einige Angaben in dieser Dokumentation können inzwischen überholt sein.

Außerhalb Deutschlands nehmen Sie bitte zuerst Kontakt mit Ihrem lokalen Ansprechpartner auf.

- Verkaufsniederlassungen
- Niederlassungen mit Kundendienst

Additional notes about service, repairs and training as well as the **actual** addresses of our sales- and service facilities are available on the Internet at **www.indramat.de** – some information in this documentation may meanwhile be obsolete.

2. Please contact the sales & service offices in your area first.

- sales agencies
- offices providing service

## 11.4 Vor der Kontaktaufnahme... - Before contacting us...

Wir können Ihnen schnell und effizient helfen wenn Sie folgende Informationen bereithalten:

3. detaillierte Beschreibung der Störung und der Umstände.
4. Angaben auf dem Typenschild der betreffenden Produkte, insbesondere Typenschlüssel und Seriennummern.
5. Tel./Faxnummern und e-Mail-Adresse, unter denen Sie für Rückfragen zu erreichen sind.

For quick and efficient help, please have the following information ready:

1. Detailed description of the failure and circumstances.
2. Information on the type plate of the affected products, especially type codes and serial numbers.
3. Your phone/fax numbers and e-mail address, so we can contact you in case of questions.

## 11.5 Kundenbetreuungsstellen - Sales & Service Facilities

### Deutschland – Germany

**vom Ausland:** (0) nach Landeskennziffer weglassen!  
**from abroad:** don't dial (0) after country code!

Vertriebsgebiet Mitte Germany Centre  Rexroth Indramat GmbH Bgm.-Dr.-Nebel-Str. 2 97816 Lohr am Main  <b>Kompetenz-Zentrum Europa</b>  Tel.: +49 (0)9352 40-0 Fax: +49 (0)9352 40-4885	<b>SERVICE</b>  <b>CALL ENTRY CENTER</b> <b>MO – FR</b> <b>von 07:00 - 18:00 Uhr</b>  <b>from 7 am – 6 pm</b>  <b>Tel. +49 (0) 9352 40 50 60</b> <a href="mailto:service@indramat.de">service@indramat.de</a>	<b>SERVICE</b>  <b>HOTLINE</b> <b>MO – FR</b> <b>von 17:00 - 07:00 Uhr</b> <b>from 5 pm - 7 am</b> + SA / SO  <b>Tel.: +49 (0)172 660 04 06</b> <b>oder / or</b> <b>Tel.: +49 (0)171 333 88 26</b>	<b>SERVICE</b>  <b>ERSATZTEILE / SPARES</b> verlängerte Ansprechzeit - extended office time - ♦ nur an Werktagen - only on working days - ♦ von 07:00 - 18:00 Uhr - from 7 am - 6 pm -  <b>Tel. +49 (0) 9352 40 42 22</b>
Vertriebsgebiet Süd Germany South  Rexroth Indramat GmbH Landshuter Allee 8-10 80637 München Tel.: +49 (0)89 127 14-0 Fax: +49 (0)89 127 14-490	Gebiet Südwest Germany South-West  Bosch Rexroth AG Vertrieb Deutschland – VD-BI Geschäftsbereich Rexroth Indramat Regionalzentrum Südwest Ringstrasse 70 / Postfach 1144 70736 Fellbach / 70701 Fellbach  Tel.: +49 (0)711 57 61-100 Fax: +49 (0)711 57 61-125	Vertriebsgebiet Ost Germany East  Bosch Rexroth AG Beckerstraße 31 09120 Chemnitz  Tel.: +49 (0)371 35 55-0 Fax: +49 (0)371 35 55-333	Vertriebsgebiet Ost Germany East  Bosch Rexroth AG Regionalzentrum Ost Walter-Köhn-Str. 4d 04356 Leipzig  Tel.: +49 (0)341 25 61-0 Fax: +49 (0)341 25 61-111
Vertriebsgebiet West Germany West  Bosch Rexroth AG Vertrieb Deutschland Regionalzentrum West Borsigstrasse 15 40880 Ratingen  Tel.: +49 (0)2102 409-0 Fax: +49 (0)2102 409-406	Vertriebsgebiet Mitte Germany Centre  Bosch Rexroth AG Regionalzentrum Mitte Waldecker Straße 13 64546 Mörfelden-Walldorf  Tel.: +49 (0) 61 05 702-3 Fax: +49 (0) 61 05 702-444	Vertriebsgebiet Nord Germany North  Bosch Rexroth AG Walsroder Str. 93 30853 Langenhagen  Tel.: +49 (0) 511 72 66 57-0 Fax: +49 (0) 511 72 66 57-95	Vertriebsgebiet Nord Germany North  Bosch Rexroth AG Kieler Straße 212 22525 Hamburg  Tel.: +49 (0) 40 81 955 966 Fax: +49 (0) 40 85 418 978

## Europa (West) - Europe (West)

**vom Ausland:** (0) nach Landeskennziffer weglassen, **Italien:** 0 nach Landeskennziffer mitwählen  
**from abroad:** don't dial (0) after country code, **Italy:** dial 0 after country code

<p>Austria - Österreich</p> <p>Bosch Rexroth GmbH Bereich Indramat Stachegasse 13 1120 Wien</p> <p>Tel.: +43 (0)1 985 25 40 Fax: +43 (0)1 985 25 40-93</p>	<p>Austria – Österreich</p> <p>Bosch Rexroth G.m.b.H. Gesch.ber. Rexroth Indramat Industriepark 18 4061 Pasching</p> <p>Tel.: +43 (0)7221 605-0 Fax: +43 (0)7221 605-21</p>	<p>Belgium - Belgien</p> <p>Bosch Rexroth AG Electric Drives &amp; Controls Industrielaan 8 1740 Ternat</p> <p>Tel.: +32 (0)2 5830719 Service: +32 (0)2 5830717 Fax: +32 (0)2 5830731 <a href="mailto:indramat@boschrexroth.be">indramat@boschrexroth.be</a></p>	<p>Denmark - Dänemark</p> <p>BEC A/S Zinkvej 6 8900 Randers</p> <p>Tel.: +45 (0)87 11 90 60 Fax: +45 (0)87 11 90 61</p>
<p>Great Britain – Großbritannien</p> <p>Bosch Rexroth Ltd. Rexroth Indramat Division Broadway Lane, South Cerney Cirencester, Glos GL7 5UH</p> <p>Tel.: +44 (0)1285 863000 Fax: +44 (0)1285 863030 <a href="mailto:sales@indramat.co.uk">sales@indramat.co.uk</a> <a href="mailto:service@indramat.co.uk">service@indramat.co.uk</a></p>	<p>Finland - Finnland</p> <p>Bosch Rexroth Oy Rexroth Indramat division Ansatie 6 017 40 Vantaa</p> <p>Tel.: +358 (0)9 84 91-11 Fax: +358 (0)9 84 91-13 60</p>	<p>France - Frankreich</p> <p>Bosch Rexroth S.A. Division Rexroth Indramat Avenue de la Trentaine BP. 74 77503 CHELLES CEDEX</p> <p>Tel.: +33 (0)164 72-70 00 Fax: +33 (0)164 72-63 00 <b>Hotline:</b> +33 (0)608 33 43 28</p>	<p>France - Frankreich</p> <p>Bosch Rexroth S.A. Division Rexroth Indramat 1270, Avenue de Lardenne 31100 Toulouse</p> <p>Tel.: +33 (0)5 61 49 95 19 Fax: +33 (0)5 61 31 00 41</p>
<p>France - Frankreich</p> <p>Bosch Rexroth S.A. Division Rexroth Indramat 91, Bd. Irène Joliot-Curie 69634 Vénissieux – Cedex</p> <p>Tel.: +33 (0)4 78 78 53 65 Fax: +33 (0)4 78 78 53 62</p>	<p>Italy - Italien</p> <p>Bosch Rexroth S.p.A. Via G. Di Vittoria, 1 20063 Cernusco S/N.MI</p> <p>Tel.: +39 02 2 365 270 Fax: +39 02 700 408 252378</p>	<p>Italy - Italien</p> <p>Bosch Rexroth S.p.A. Via Paolo Veronesi, 250 10148 Torino</p> <p>Tel.: +39 011 224 88 11 Fax: +39 011 220 48 04</p>	<p>Italy - Italien</p> <p>Bosch Rexroth S.p.A. Via del Progresso, 16 (Zona Ind.) 35020 Padova</p> <p>Tel.: +39 049 8 70 13 70 Fax: +39 049 8 70 13 77</p>
<p>Italy - Italien</p> <p>Bosch Rexroth S.p.A. Via Mascia, 1 80053 Castellamare di Stabia NA</p> <p>Tel.: +39 081 8 71 57 00 Fax: +39 081 8 71 68 85</p>	<p>Italy - Italien</p> <p>Bosch Rexroth S.p.A. Viale Oriani, 38/A 40137 Bologna</p> <p>Tel.: +39 051 34 14 14 Fax: +39 051 34 14 22</p>	<p>Netherlands - Niederlande/Holland</p> <p>Bosch Rexroth B.V. Kruisbroeksestraat 1 (P.O. Box 32) 5281 RV Boxtel</p> <p>Tel.: +31 (0)411 65 19 51 Fax: +31 (0)411 65 14 83 <a href="mailto:indramat@hydraudyne.nl">indramat@hydraudyne.nl</a></p>	<p>Netherlands - Niederlande/Holland</p> <p>Bosch Rexroth Services B.V. Kruisbroeksestraat 1 (P.O. Box 32) 5281 RV Boxtel</p> <p>Tel.: +31 (0)411 65 19 51 Fax: +31 (0)411 67 78 14</p>
<p>Norway - Norwegen</p> <p>Bosch Rexroth AS Rexroth Indramat Division Berghagan 1 or: Box 3007 1405 Ski-Langhus 1402 Ski</p> <p>Tel.: +47 (0)64 86 41 00 Fax: +47 (0)64 86 90 62 <a href="mailto:jul.ruud@rexroth.no">jul.ruud@rexroth.no</a></p>	<p>Spain - Spanien</p> <p>Bosch Rexroth S.A. Divisiòn Rexroth Indramat Centro Industrial Santiga Obradors s/n 08130 Santa Perpetua de Mogoda Barcelona</p> <p>Tel.: +34 9 37 47 94 00 Fax: +34 9 37 47 94 01</p>	<p>Spain - Spanien</p> <p>Goimendi S.A. Divisiòn Rexroth Indramat Parque Empresarial Zuatzu C/ Francisco Grandmontagne no.2 20018 San Sebastian</p> <p>Tel.: +34 9 43 31 84 21 - service: +34 9 43 31 84 56 Fax: +34 9 43 31 84 27 - service: +34 9 43 31 84 60 <a href="mailto:satindramat-goimendi@adegi.es">satindramat-goimendi@adegi.es</a></p>	<p>Sweden - Schweden</p> <p>Rexroth Mecman Svenska AB Rexroth Indramat Division Varuvågen 7 125 81 Stockholm</p> <p>Tel.: +46 (0)8 727 92 00 Fax: +46 (0)8 647 32 77</p>
<p>Sweden - Schweden</p> <p>Rexroth Mecman Svenska AB Indramat Support Ekvåndan 7 254 67 Helsingborg</p> <p>Tel.: +46 (0) 42 38 88 -50 Fax: +46 (0) 42 38 88 -74</p>	<p>Switzerland West - Schweiz West</p> <p>Bosch Rexroth Suisse SA Département Rexroth Indramat Rue du village 1 1020 Renens</p> <p>Tel.: +41 (0)21 632 84 20 Fax: +41 (0)21 632 84 21</p>	<p>Switzerland East - Schweiz Ost</p> <p>Bosch Rexroth Schweiz AG Geschäftsbereich Indramat Hemrietstrasse 2 8863 Buttikon</p> <p>Tel. +41 (0) 55 46 46 205 Fax +41 (0) 55 46 46 222</p>	

## Europa (Ost) - Europe (East)

**vom Ausland:** (0) nach Landeskennziffer weglassen  
**from abroad:** don't dial (0) after country code

Czech Republic - Tschechien	Czech Republic - Tschechien	Hungary - Ungarn	Poland – Polen
Bosch -Rexroth, spol.s.r.o. Hviezdoslavova 5 627 00 Brno  Tel.: +420 (0)5 48 126 358 Fax: +420 (0)5 48 126 112	DEL a.s. Strojirenská 38 Zdar nad Sázavou 591 01 Czech republic  Tel.: +420 616 64 3144 Fax: +420 616 216 57	Bosch Rexroth Kft. Angol utca 34 1149 Budapest  Tel.: +36 (1) 364 00 02 Fax: +36 (1) 383 19 80	Bosch Rexroth Sp.zo.o. Biuro Poznan ul. Dabrowskiego 81/85 60-529 Poznan  Tel.: +48 061 847 64 62 /-63 Fax: +48 061 847 64 02
Rumania - Rumänien	Russia - Russland	Russia - Russland	Turkey - Türkei
Bosch Rexroth Sp.zo.o. Str. Drobety nr. 4-10, app. 14 70258 Bucuresti, Sector 2  Tel.: +40 (0)1 210 48 25 +40 (0)1 210 29 50 Fax: +40 (0)1 210 29 52	Bosch Rexroth Wolokolamskoje Chaussee 73 Zimmer 406, 408 123424 Moskau  Tel.: +7 095/ 232 08 34 +7 095/ 232 08 35 Fax: +7 095/ 232 08 36 <a href="mailto:info.rex@rexroth.ru">info.rex@rexroth.ru</a>	ELMIS 10, Internationalnaya Str. 246640 Gomel, Belarus  Tel.: +375/ 232 53 42 70 Fax: +375/ 232 53 37 69 <a href="mailto:elmis_ltd@yahoo.com">elmis_ltd@yahoo.com</a>	Bosch Rexroth Otomasyon San & Tic. A.S. Fevzi Cakmak Cad No. 3 34630 Sefaköy Istanbul  Tel.: +90 212 541 60 70 Fax: +90 212 599 34 07
Slowenia - Slowenien			
DOMEL Otoki 21 64 228 Zelezniki  Tel.: +386 5 5117 152 Fax: +386 5 5117 225 <a href="mailto:brane.ozebek@domel.si">brane.ozebek@domel.si</a>			

## Africa, Asia, Australia – incl. Pacific Rim

**vom Ausland:** (0) nach Landeskennziffer weglassen!  
**from abroad:** don't dial (0) after country code!

<p>Australia - Australien</p> <p>AIMS - Australian Industrial Machinery Services Pty. Ltd.                  A-5F., 123 Lian Shan Street                  Unit 3/45 Horne ST                  Campbellfield, VIC 3061                  Melbourne</p> <p>Tel.: +61 (0) 393 590 228                  Fax: +61 (0) 393 590 286                  Hotline: +61 (0) 419 369 195  <a href="mailto:terryobrien@aimservices.com.au">terryobrien@aimservices.com.au</a></p>	<p>Australia - Australien</p> <p>Bosch Rexroth Pty. Ltd.                  No. 7, Endeavour Way                  Braeside Victoria, 31 95                  Melbourne</p> <p>Tel.: +61 (0)3 95 80 39 33                  Fax: +61 (0)3 95 80 17 33  <a href="mailto:mel@rexroth.com.au">mel@rexroth.com.au</a></p>	<p>China</p> <p>Shanghai Bosch Rexroth Hydraulics &amp; Automation Ltd.                  Wai Gao Qiao Free Trade Zone                  No.122, Fu Te Dong Yi Road                  Shanghai 200131 - P.R.China</p> <p>Tel.: +86 21 58 66 30 30                  Fax: +86 21 58 66 55 23  <a href="mailto:roger.shi_sh@boschrexroth.com.cn">roger.shi_sh@boschrexroth.com.cn</a></p>	<p>China</p> <p>Bosch Rexroth (China) Ltd.                  15/F China World Trade Center                  1, Jianguomenwai Avenue                  Beijing 100004, P.R.China</p> <p>Tel.: +86 10 65 05 03 80                  Fax: +86 10 65 05 03 79</p>
<p>China</p> <p>Bosch Rexroth (China) Ltd.                  A-5F., 123 Lian Shan Street                  Sha He Kou District                  Dalian 116 023, P.R.China</p> <p>Tel.: +86 411 46 78 930                  Fax: +86 411 46 78 932</p>	<p>China</p> <p>Bosch Rexroth (Changzhou) Co.Ltd.                  Guangzhou Repres. Office                  Room 1014-1016, Metro Plaza,                  Tian He District, 183 Tian He Bei Rd                  Guangzhou 510075, P.R.China</p> <p>Tel.: +86 20 8755-0030                  +86 20 8755-0011                  Fax: +86 20 8755-2387</p>	<p>Hongkong</p> <p>Bosch Rexroth (China) Ltd.                  6<sup>th</sup> Floor,                  Yeung Yiu Chung No.6 Ind Bldg.                  19 Cheung Shun Street                  Cheung Sha Wan,                  Kowloon, Hongkong</p> <p>Tel.: +852 22 62 51 00                  Fax: +852 27 41 33 44  <a href="mailto:alexis.siu@boschrexroth.com.hk">alexis.siu@boschrexroth.com.hk</a></p>	<p>India - Indien</p> <p>Bosch Rexroth (India) Ltd.                  Rexroth Indramat Division                  Plot. A-58, TTC Industrial Area                  Thane Turbhe Midc Road                  Mahape Village                  Navi Mumbai - 400 701</p> <p>Tel.: +91 (0)22 7 61 46 22                  Fax: +91 (0)22 7 68 15 31</p>
<p>India - Indien</p> <p>Bosch Rexroth (India) Ltd.                  Rexroth Indramat Division                  Plot. 96, Phase III                  Peenya Industrial Area                  Bangalore - 560058</p> <p>Tel.: +91 (0)80 8 39 73 74                  Fax: +91 (0)80 8 39 43 45</p>	<p>Indonesia - Indonesien</p> <p>PT. Rexroth Wijayakusuma                  Building # 202, Cilandak                  Commercial Estate                  Jl. Cilandak KKO, Jakarta 12560</p> <p>Tel.: +62 21 7891169 (5 lines)                  Fax: +62 21 7891170 - 71</p>	<p>Japan</p> <p>Bosch Rexroth Automation Corp.                  Service Center Japan                  Yutakagaoka 1810, Meito-ku,                  NAGOYA 465-0035, Japan</p> <p>Tel.: +81 (0)52 777 88 41                  +81 (0)52 777 88 53                  +81 (0)52 777 88 79                  Fax: +81 (0)52 777 89 01</p>	<p>Japan</p> <p>Bosch Rexroth Automation Corp.                  Rexroth Indramat Division                  1F, I.R. Building                  Nakamachidai 4-26-44, Tsuzuki-ku                  YOKOHAMA 224-0041, Japan</p> <p>Tel.: +81 (0)45 942 72 10                  Fax: +81 (0)45 942 03 41</p>
<p>Korea</p> <p>Bosch Rexroth-Korea Ltd.                  1515-14 Dadae-Dong, Saha-Ku                  Rexroth Indramat Division                  Pusan Metropolitan City, 604-050                  Republic of South Korea</p> <p>Tel.: +82 (0)51 26 00 741                  Fax: +82 (0)51 26 00 747  <a href="mailto:gyhan@rexrothkorea.co.kr">gyhan@rexrothkorea.co.kr</a></p>	<p>Malaysia</p> <p>Bosch Rexroth Sdn.Bhd.                  11, Jalan U8/82                  Seksyen U8                  40150 Shah Alam                  Selangor, Malaysia</p> <p>Tel.: +60 (0) 3 78 44 80 00                  Fax: +60 (0) 3 78 45 48 00  <a href="mailto:hockhwa@hotmail.com">hockhwa@hotmail.com</a>  <a href="mailto:rexroth1@tm.net.my">rexroth1@tm.net.my</a></p>	<p>Singapore - Singapur</p> <p>Robert Bosch (SEA) Pte Ltd.                  Dept. RBSI-R/SAT                  38-C Jalan Pemimpin                  Singapore 577180</p> <p>Tel.: +65 35 05 470                  Fax: +65 35 05 313  <a href="mailto:kenton.peh@sg.bosch.com">kenton.peh@sg.bosch.com</a></p>	<p>South Africa - Südafrika</p> <p>TECTRA Automation (Pty) Ltd.                  28 Banfield Road, Industria North                  Maraisburg 1700</p> <p>Tel.: +27 (0)11 673 20 80                  Fax: +27 (0)11 673 72 69                  Hotline: +27 (0)82 903 29 23  <a href="mailto:georgv@tectra.co.za">georgv@tectra.co.za</a></p>
<p>Taiwan</p> <p>Rexroth Uchida Co., Ltd.                  No.17, Lane 136, Cheng Bei 1 Rd.,                  Yungkang, Tainan Hsien                  Taiwan, R.O.C.</p> <p>Tel.: +886 (0)6 25 36 565                  Fax: +886 (0)6 25 34 754  <a href="mailto:indramat@mail.net.tw">indramat@mail.net.tw</a></p>	<p>Thailand</p> <p>NC Advance Technology Co. Ltd.                  59/76 Moo 9                  Ramintra road 34                  Tharang, Bangkhen,                  Bangkok 10230</p> <p>Tel.: +66 2 943 70 62                  +66 2 943 71 21                  Fax: +66 2 509 23 62  <a href="mailto:sonkawin@hotmail.com">sonkawin@hotmail.com</a></p>		

## Nordamerika – North America

<p>USA Hauptniederlassung - Headquarters</p> <p>Bosch Rexroth Corporation Rexroth Indramat Division 5150 Prairie Stone Parkway Hoffman Estates, IL 60192-3707</p> <p>Tel.: +1 847 6 45 36 00 Fax: +1 847 6 45 62 01 <a href="mailto:service@indramat.com">service@indramat.com</a></p>	<p>USA Central Region - Mitte</p> <p>Bosch Rexroth Corporation Rexroth Indramat Division Central Region Technical Center 1701 Harmon Road Auburn Hills, MI 48326</p> <p>Tel.: +1 248 3 93 33 30 Fax: +1 248 3 93 29 06</p>	<p>USA Southeast Region - Südwest</p> <p>Bosch Rexroth Corporation Rexroth Indramat Division Southeastern Technical Center 3625 Swiftwater Park Drive Suwanee, Georgia 30124</p> <p>Tel.: +1 770 9 32 32 00 Fax: +1 770 9 32 19 03</p>	<p>USA SERVICE-HOTLINE</p> <p>- 7 days x 24hrs -</p> <p><b>+1-800-860-1055</b></p>
<p>USA East Region –Ost</p> <p>Bosch Rexroth Corporation Rexroth Indramat Division Charlotte Regional Sales Office 14001 South Lakes Drive Charlotte, North Carolina 28273</p> <p>Tel.: +1 704 5 83 97 62 +1 704 5 83 14 86</p>	<p>USA Northeast Region – Nordost</p> <p>Bosch Rexroth Corporation Rexroth Indramat Division Northeastern Technical Center 99 Rainbow Road East Granby, Connecticut 06026</p> <p>Tel.: +1 860 8 44 83 77 Fax: +1 860 8 44 85 95</p>	<p>USA West Region – West</p> <p>Bosch Rexroth Corporation 7901 Stoneridge Drive, Suite 220 Pleasant Hill, California 94588</p> <p>Tel.: +1 925 227 10 84 Fax: +1 925 227 10 81</p>	
<p>Canada East - Kanada Ost</p> <p>Bosch Rexroth Canada Corporation Burlington Division 3426 Mainway Drive Burlington, Ontario Canada L7M 1A8</p> <p>Tel.: +1 905 335 55 11 Fax: +1 905 335-41 84 <a href="mailto:michael.moro@boschrexroth.ca">michael.moro@boschrexroth.ca</a></p>	<p>Canada West - Kanada West</p> <p>Bosch Rexroth Canada Corporation 5345 Goring St. Burnaby, British Columbia Canada V7J 1R1</p> <p>Tel. +1 604 205-5777 Fax +1 604 205-6944 <a href="mailto:david.gunby@boschrexroth.ca">david.gunby@boschrexroth.ca</a></p>	<p>Mexico</p> <p>Bosch Rexroth S.A. de C.V. Calle Neptuno 72 Unidad Ind. Vallejo 07700 Mexico, D.F.</p> <p>Tel.: +52 5 754 17 11 +52 5 754 36 84 +52 5 754 12 60 Fax: +52 5 754 50 73 +52 5 752 59 43</p>	<p>Mexico</p> <p>Bosch Rexroth S.A. de C.V. Calle Argentina No 3913 Fracc. las Torres 64930 Monterey, N.L.</p> <p>Tel.: +52 8 333 88 34...36 +52 8 349 80 91...93 Fax: +52 8 346 78 71 <a href="mailto:mario.quiroga@boschrexroth.com.mx">mario.quiroga@boschrexroth.com.mx</a></p>

## Südamerika – South America

<p>Argentina - Argentinien</p> <p>Bosch Rexroth S.A.I.C. "The Drive &amp; Control Company" Acassuso 48 41/47 1605 Munro Prov. Buenos Aires</p> <p>Tel.: +54 (0)11 4756 01 40 Fax: +54 (0)11 4756 01 36 <a href="mailto:mannesmann@mannesmannsaic.com.ar">mannesmann@mannesmannsaic.com.ar</a></p>	<p>Argentina - Argentinien</p> <p>NAKASE Servicio Tecnico CNC Calle 49, No. 5764/66 1653 Villa Balester Prov. - Buenos Aires</p> <p>Tel.: +54 (0) 11 4768 36 43 Fax: +54 (0) 11 4768 24 13 <a href="mailto:nakase@usa.net">nakase@usa.net</a> <a href="http://nakase.com">nakase.com</a></p>	<p>Brazil - Brasilien</p> <p>Bosch Rexroth Ltda. Av. Tégula, 888 Ponte Alta, Atibaia SP CEP 12942-440</p> <p>Tel.: +55 (0)11 4414 56 92 +55 (0)11 4414 56 84 Fax sales: +55 (0)11 4414 57 07 Fax serv.: +55 (0)11 4414 56 86 <a href="mailto:alexandre.wittwer@rexroth.com.br">alexandre.wittwer@rexroth.com.br</a></p>	<p>Brazil - Brasilien</p> <p>Bosch Rexroth Ltda. R. Dr.Humberto Pinheiro Vieira, 100 Distrito Industrial [Caixa Postal 1273] 89220-390 Joinville - SC</p> <p>Tel./Fax: +55 (0)47 473 58 33 Mobil: +55 (0)47 9974 6645 <a href="mailto:prochnow@zaz.com.br">prochnow@zaz.com.br</a></p>
<p>Columbia - Kolumbien</p> <p>Reflutec de Colombia Ltda. Calle 37 No. 22-31 Santafé de Bogotá, D.C. Colombia</p> <p>Tel.: +57 1 368 82 67 +57 1 368 02 59 Fax: +57 1 268 97 37 <a href="mailto:reflutec@inter.net.co">reflutec@inter.net.co</a></p>			





Printed in Germany