

## RECO Inline Profibus DP Terminal and Module Supply

Functional Description

SYSTEM200

**Title** RECO Inline  
 Profibus DP Terminal  
 and Module Supply

**Type of Documentation** Functional Description

**Document Typecode** DOK-CONTRL-R-IL-PB\*-BK-FK02-EN-P

**Internal File Reference** Document Number, 120-0400-B341-02/EN

**Purpose of Documentation** This documentation serves

- as general information for the module terminals,
- to specify the technical data,
- to specify diagrams and formulas,
- as reference book for detailed information.

**Record of Revisions**

Description	Release Date	Notes
120-0400-B341-02/EN	07/01	First issue

**Copyright** © 2001 Rexroth Indramat GmbH

Copying this document, giving it to others and the use or communication of the contents thereof without express authority, are forbidden. Offenders are liable for the payment of damages. All rights are reserved in the event of the grant of a patent or the registration of a utility model or design (DIN 34-1).

**Validity** The specified data is for product description purposes only and may not be deemed to be guaranteed unless expressly confirmed in the contract. All rights are reserved with respect to the content of this documentation and the availability of the product.

**Published by** Rexroth Indramat GmbH  
 Bgm.-Dr.-Nebel-Str. 2 • D-97816 Lohr a. Main  
 Telephone +49 (0)93 52/40-0 • Tx 68 94 21 • Fax +49 (0)93 52/40-48 85  
<http://www.boschrexroth.de/>  
 Dept. EP6 (UK)  
 Dept. EP7 (CV)  
 Dept. EP (NH)

**Note** This document has been printed on chlorine-free bleached paper.

# Contents

<b>1</b>	<b>Presentation of the Components</b>	<b>1-1</b>
1.1	Description of the elements and basic functions .....	1-1
<b>2</b>	<b>Important directions for use</b>	<b>2-1</b>
2.1	Appropriate use .....	2-1
	Introduction .....	2-1
	Areas of use and application.....	2-2
2.2	Inappropriate use .....	2-2
<b>3</b>	<b>Safety Instructions for Electric Servo Drives and Controls</b>	<b>3-3</b>
3.1	Introduction.....	3-3
3.2	Explanations.....	3-3
3.3	Hazards by inappropriate use .....	3-4
3.4	General Information .....	3-5
3.5	Protection against contact with electrical parts.....	3-6
3.6	Protection by protective low voltage (PELV) against electrical shock .....	3-8
3.7	Protection against dangerous movements.....	3-8
3.8	Protection against magnetic and electromagnetic fields during operations and mounting.....	3-10
3.9	Protection against contact with hot parts .....	3-11
3.10	Protection during handling and installation .....	3-11
3.11	Battery safety .....	3-12
3.12	Protection against pressurized Systems.....	3-12
<b>4</b>	<b>PROFIBUS Coupler R-IL PB BK</b>	<b>4-1</b>
4.1	Presentation and Application .....	4-1
	Characteristics .....	4-1
	Display elements.....	4-3
	Standard and device-defined diagnosis for each PROFIBUS .....	4-4
4.2	Connection of the PROFIBUS.....	4-5
	Feed in operating voltages.....	4-5
	Configuring the hardware.....	4-6
	System termination resistors.....	4-7
4.3	Permissible RECO Inline devices .....	4-8
4.4	Technical Data .....	4-10
	General data .....	4-10
	System data .....	4-10
	PROFIBUS DP Interface.....	4-10
	Data of the voltage supply .....	4-11

Compliance with the EMC Guideline 89/336/EEC.....	4-12
<b>5 Power terminal IB IL 24 PWR IN</b>	<b>5-1</b>
5.1 Representation and Description of Application.....	5-1
Characteristics .....	5-1
Indication elements .....	5-2
5.2 Technical data.....	5-3
5.3 Connections .....	5-4
Position of the terminals.....	5-4
Terminal assignment.....	5-4
Internal block diagram.....	5-5
Example of a connection.....	5-6
5.4 Electrical isolation .....	5-7
<b>6 Segment Terminal R-IB IL 24 SEG/F</b>	<b>6-1</b>
6.1 Representation and Description of Application.....	6-1
Characteristics .....	6-1
Display elements.....	6-2
6.2 Technical data.....	6-3
6.3 Connections .....	6-4
Position of the terminals.....	6-4
Terminal assignment.....	6-4
Internal block diagram.....	6-5
6.4 Electrical isolation .....	6-6
6.5 Diagrams and formulas.....	6-7
Derating.....	6-7
Voltage characteristics in the segment circuit in case of a fuse defect .....	6-7
Power loss.....	6-9
<b>7 Order Information</b>	<b>7-1</b>
7.1 Order identification .....	7-1
<b>8 List of figures</b>	<b>8-1</b>
<b>9 Index</b>	<b>9-1</b>
<b>10 Service &amp; Support</b>	<b>10-1</b>
10.1 Helpdesk .....	10-1
10.2 Service-Hotline.....	10-1
10.3 Internet .....	10-1
10.4 Vor der Kontaktaufnahme... - Before contacting us.....	10-1
10.5 Kundenbetreuungsstellen - Sales & Service Facilities .....	10-2

# 1 Presentation of the Components

## 1.1 Description of the elements and basic functions

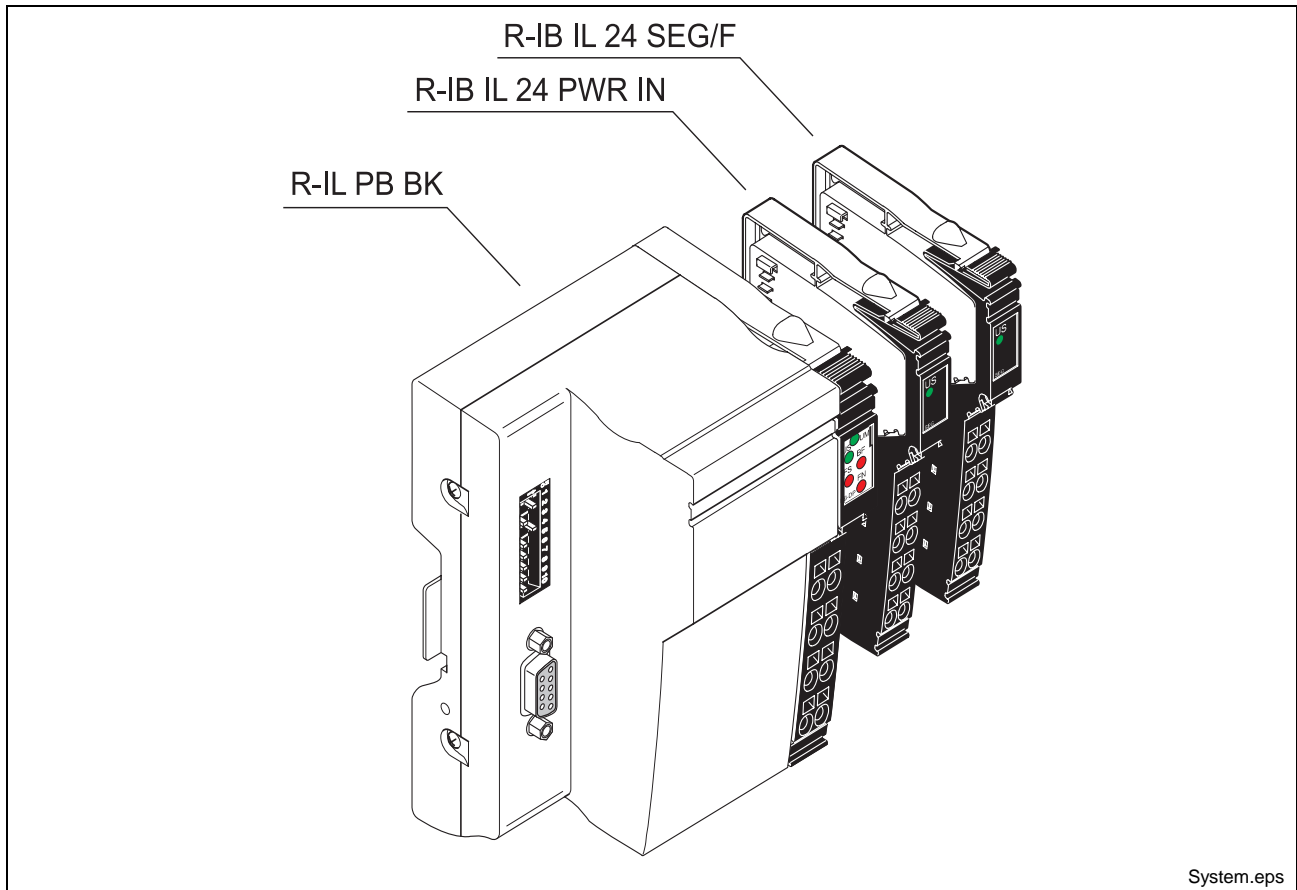

Fig. 1-1: Remote bus terminals and supply modules

The description includes the following components:

- PROFIBUS DP fieldbus coupler  
R-IL PB BK
- INTERBUS Inline power terminal without fuse  
R-IB IL 24 PWR IN
- INTERBUS Inline segment terminal without fuse  
R-IB IL 24 SEG/F

---

**Note:** This function description is valid only in connection with the application description "Project Planning and Installation of the Module Family Inline DOK-CONTRL-R-IL\*PBSSYS".

---



## 2 Important directions for use

### 2.1 Appropriate use

#### Introduction

Rexroth Indramat products represent state-of-the-art developments and manufacturing. They are tested prior to delivery to ensure operating safety and reliability.

The products may only be used in the manner that is defined as appropriate. If they are used in an inappropriate manner, then situations can develop that may lead to property damage or injury to personnel.

---

**Note:** Rexroth Indramat, as manufacturer, is not liable for any damages resulting from inappropriate use. In such cases, the guarantee and the right to payment of damages resulting from inappropriate use are forfeited. The user alone carries all responsibility of the risks.

---

Before using Rexroth Indramat products, make sure that all the prerequisites for appropriate use of the products are satisfied:

- Personnel that in any way, shape or form uses our products must first read and understand the relevant safety instructions and be familiar with appropriate use.
- If the product takes the form of hardware, then they must remain in their original state, in other words, no structural changes are permitted. It is not permitted to decompile software products or alter source codes.
- Do not mount damaged or faulty products or use them in operation.
- Make sure that the products have been installed in the manner described in the relevant documentation.

## Areas of use and application

The RECO Inline system is a decentralized modular fieldbus-coupled input and output system.

The RECO Inline system by Rexroth Indramat is intended for the cases of use listed below.

- Machine tools
- Transfer systems
- General automation

---

**Note:** The RECO Inline system may only be used with the accessories and parts specified in this document. If a component has not been specifically named, then it may not be either mounted or connected. The same applies to cables and lines.

Operation is only permitted in the specified configurations and combinations of components using the software and firmware as specified in the relevant function descriptions.

---

The typical fields of application of RECO Inline modules are as follows:

- Turning machines
- Milling machines
- Machining centers
- General automation

The RECO Inline system may only be operated under the assembly, installation and ambient conditions as described here (temperature, system of protection, humidity, EMC requirements, etc.) and in the position specified.

## 2.2 Inappropriate use

Using the RECO Inline system outside of the above-referenced areas of application or under operating conditions other than described in the document and the technical data specified is defined as "inappropriate use".

The RECO Inline system may not be used if

- they are subject to operating conditions that do not meet the above specified ambient conditions. This includes, for example, operation under water, in the case of extreme temperature fluctuations or extreme maximum temperatures or if
- Rexroth Indramat has not specifically released them for that intended purpose. Please note the specifications outlined in the general Safety Instructions!

# 3 Safety Instructions for Electric Servo Drives and Controls

## 3.1 Introduction

Read these instructions before the equipment is used and eliminate the risk of personal injury or property damage. Follow these safety instructions at all times.

Do not attempt to install, use or service this equipment without first reading all documentation provided with the product. Read and understand these safety instructions and all user documentation of the equipment prior to working with the equipment at any time. If you do not have the user documentation for your equipment contact your local Rexroth Indramat representative to send this documentation immediately to the person or persons responsible for the safe operation of this equipment.

If the product is resold, rented or transferred or passed on to others, then these safety instructions must be delivered with the product.



**Inappropriate use of this equipment, failure to follow the safety instructions in this document or tampering with the product, including disabling of safety devices, may result in product damage, personal injury, severe electrical shock or death!**

## 3.2 Explanations

The safety warnings in this documentation describe individual degrees of hazard seriousness in compliance with ANSI:

Warning symbol with signal word	Degree of hazard seriousness
	The degree of hazard seriousness describes the consequences resulting from non-compliance with the safety guidelines.  Bodily harm or product damage will occur.
	Death or severe bodily harm may occur.
	Death or severe bodily harm may occur.

Fig. 3-1: Classes of danger with ANSI

### 3.3 Hazards by inappropriate use



**DANGER**

**High voltage and high discharge current!  
Danger to life, risk of severe electrical shock  
and risk of injury!**



**DANGER**

**Dangerous movements! Danger to life and risk  
of injury or equipment damage by unintentional  
motor movements!**



**WARNING**

**High electrical voltage due to wrong  
connections! Danger to life, severe electrical  
shock and severe bodily injury!**



**WARNING**

**Health hazard for persons with heart  
pacemakers, metal implants and hearing aids in  
proximity to electrical equipment!**



**CAUTION**

**Surface of machine housing could be extremely  
hot! Danger of injury! Danger of burns!**



**CAUTION**

**Risk of injury due to inappropriate handling!  
Bodily injury caused by crushing, shearing,  
cutting and mechanical shock or improper  
handling of pressurized systems!**



**CAUTION**

**Risk of injury due to inappropriate handling of  
batteries!**

## 3.4 General Information

- Rexroth Indramat GmbH is not liable for damages resulting from failure to observe the warnings given in these documentation.
- Order operating, maintenance and safety instructions in your language before starting up the machine. If you find that due to a translation error you can not completely understand the documentation for your product, please ask your supplier to clarify.
- Proper and correct transport, storage, assembly and installation as well as care in operation and maintenance are prerequisites for optimal and safe operation of this equipment.
- Trained and qualified personnel in electrical equipment:  
Only trained and qualified personnel may work on this equipment or within its proximity. Personnel are qualified if they have sufficient knowledge of the assembly, installation and operation of the product as well as an understanding of all warnings and precautionary measures noted in these instructions.  
Furthermore, they should be trained, instructed and qualified to switch electrical circuits and equipment on and off, to ground them and to mark them according to the requirements of safe work practices and common sense. They must have adequate safety equipment and be trained in first aid.
- Only use spare parts and accessories approved by the manufacturer.
- Follow all safety regulations and requirements for the specific application as practiced in the country of use.
- The equipment is designed for installation on commercial machinery.  
European countries: see directive 89/392/EEC (machine guideline).
- The ambient conditions given in the product documentation must be observed.
- Use only safety features that are clearly and explicitly approved in the Project Planning manual.  
For example, the following areas of use are not allowed: Construction cranes, Elevators used for people or freight, Devices and vehicles to transport people, Medical applications, Refinery plants, the transport of hazardous goods, Radioactive or nuclear applications, Applications sensitive to high frequency, mining, food processing, Control of protection equipment (also in a machine).
- Start-up is only permitted once it is sure that the machine, in which the product is installed, complies with the requirements of national safety regulations and safety specifications of the application.
- Operation is only permitted if the national EMC regulations for the application are met.  
The instructions for installation in accordance with EMC requirements can be found in the INDRAMAT document "EMC in Drive and Control Systems".  
The machine builder is responsible for compliance with the limiting values as prescribed in the national regulations and specific EMC regulations for the application.  
European countries: see Directive 89/336/EEC (EMC Guideline).  
U.S.A.: See National Electrical Codes (NEC), National Electrical Manufacturers Association (NEMA), and local building codes. The user of this equipment must consult the above noted items at all times.
- Technical data, connections and operational conditions are specified in the product documentation and must be followed at all times.

## 3.5 Protection against contact with electrical parts

---

**Note:** This section refers to equipment with voltages above 50 Volts.

---

Making contact with parts conducting voltages above 50 Volts could be dangerous to personnel and cause an electrical shock. When operating electrical equipment, it is unavoidable that some parts of the unit conduct dangerous voltages.

---



**DANGER**

### High electrical voltage! Danger to life, severe electrical shock and severe bodily injury!

- ⇒ Only those trained and qualified to work with or on electrical equipment are permitted to operate, maintain or repair this equipment.
- ⇒ Follow general construction and safety regulations when working on electrical installations.
- ⇒ Before switching on power the ground wire must be permanently connected to all electrical units according to the connection diagram.
- ⇒ Do not operate electrical equipment at any time if the ground wire is not permanently connected, even for brief measurements or tests.
- ⇒ Before working with electrical parts with voltage potentials higher than 50 V, the equipment must be disconnected from the mains voltage or power supply.
- ⇒ The following should be observed with electrical drives, power supplies, and filter components:  
Wait five (5) minutes after switching off power to allow capacitors to discharge before beginning work. Measure the voltage on the capacitors before beginning work to make sure that the equipment is safe to touch.
- ⇒ Never touch the electrical connection points of a component while power is turned on.
- ⇒ Install the covers and guards provided with the equipment properly before switching the equipment on. Prevent contact with live parts at any time.
- ⇒ A residual-current-operated protective device (r.c.d.) must not be used on an electric drive! Indirect contact must be prevented by other means, for example, by an overcurrent protective device.
- ⇒ Equipment that is built into machines must be secured against direct contact. Use appropriate housings, for example a control cabinet.

European countries: according to EN 50178/1998, section 5.3.2.3.

U.S.A: See National Electrical Codes (NEC), National Electrical Manufacturers Association (NEMA) and local building codes. The user of this equipment must observe the above noted instructions at all times.

---

To be observed with electrical drives, power supplies, and filter components:



**DANGER**

**High electrical voltage! High leakage current!  
Danger to life, danger of injury and bodily harm  
from electrical shock!**

- ⇒ Before switching on power for electrical units, all housings and motors must be permanently grounded according to the connection diagram. This applies even for brief tests.
- ⇒ Leakage current exceeds 3.5 mA. Therefore the electrical equipment and units must always be firmly connected to the supply network.
- ⇒ Use a copper conductor with at least 10 mm<sup>2</sup> cross section over its entire course for this protective connection!
- ⇒ Prior to startups, even for brief tests, always connect the protective conductor or connect with ground wire. High voltage levels can occur on the housing that could lead to severe electrical shock and personal injury.

European countries: EN 50178/1998, section 5.3.2.1.

USA: See National Electrical Codes (NEC), National Electrical Manufacturers Association (NEMA), and local building codes. The user of this equipment must maintain the above noted instructions at all times.

### 3.6 Protection by protective low voltage (PELV) against electrical shock

All connections and terminals with voltages between 5 and 50 Volts on INDRAMAT products are protective low voltages designed in accordance with the following standards on contact safety:

- International: IEC 364-4-411.1.5
- EU countries: see EN 50178/1998, section 5.2.8.1.



**WARNING**

#### **High electrical voltage due to wrong connections! Danger to life, severe electrical shock and severe bodily injury!**

- ⇒ Only equipment, electrical components and cables of the protective low voltage type (PELV = Protective Extra Low Voltage) may be connected to all terminals and clamps with 0 to 50 Volts.
- ⇒ Only safely isolated voltages and electrical circuits may be connected. Safe isolation is achieved, for example, with an isolating transformer, an opto-electronic coupler or when battery-operated.

### 3.7 Protection against dangerous movements

Dangerous movements can be caused by faulty control or the connected motors. These causes are be various such as:

- unclean or wrong wiring of cable connections
- inappropriate or wrong operation of equipment
- malfunction of sensors, encoders and monitoring circuits
- defective components
- software errors

Dangerous movements can occur immediately after equipment is switched on or even after an unspecified time of trouble-free operation.

The monitors in the drive components make faulty operation almost impossible. Regarding personnel safety, especially the danger of bodily harm and property damage, this alone should not be relied upon to ensure complete safety. Until the built-in monitors become active and effective, it must be assumed in any case that some faulty drive movements will occur. The extent of these faulty drive movements depends upon the type of control and the state of operation.

**DANGER****Dangerous movements! Danger to life and risk of injury or equipment damage!**

⇒ Personnel protection must be secured for the above listed reason by means of superordinate monitors or measures.

These are instituted in accordance with the specific situation of the facility and a danger and fault analysis conducted by the manufacturer of the facility. All the safety regulations that apply to this facility are included therein. By switching off, circumventing or if safety devices have simply not been activated, then random machine movements or other types of faults can occur.

**Avoiding accidents, injury or property damage:**

⇒ Keep free and clear of the machine's range of motion and moving parts. Prevent people from accidentally entering the machine's range of movement:

- use protective fences
- use protective railings
- install protective coverings
- install light curtains or light barriers

⇒ Fences must be strong enough to withstand maximum possible momentum.

⇒ Mount the emergency stop switch (E-stop) in the immediate reach of the operator. Verify that the emergency stop works before startup. Don't operate the machine if the emergency stop is not working.

⇒ Isolate the drive power connection by means of an emergency stop circuit or use a start-inhibit system to prevent unintentional start-up.

⇒ Make sure that the drives are brought to standstill before accessing or entering the danger zone.

⇒ Secure vertical axes against falling or slipping after switching off the motor power by, for example:

- Mechanically securing the vertical axes
- Adding an external brake / clamping mechanism
- Balancing and thus compensating for the vertical axes mass and the gravitational force

The standard equipment motor brake or an external brake controlled directly by the servo drive are not sufficient to guarantee the safety of personnel!

- ⇒ Disconnect electrical power to the equipment using a master switch and secure the switch against reconnection for:
    - maintenance and repair work
    - cleaning of equipment
    - long periods of discontinued equipment use
  - ⇒ Avoid operating high-frequency, remote control and radio equipment near electronics circuits and supply leads. If use of such equipment cannot be avoided, verify the system and the plant for possible malfunctions at all possible positions of normal use before the first start-up. If necessary, perform a special electromagnetic compatibility (EMC) test on the plant.
- 

### 3.8 Protection against magnetic and electromagnetic fields during operations and mounting

Magnetic and electromagnetic fields generated by current-carrying conductors and permanent magnets in motors represent a serious health hazard to persons with heart pacemakers, metal implants and hearing aids.

---



**WARNING**

- Health hazard for persons with heart pacemakers, metal implants and hearing aids in proximity to electrical equipment!**
- ⇒ Persons with pacemakers, metal implants and hearing aids are not permitted to enter following areas:
    - Areas in which electrical equipment and parts are mounted, being operated or started up.
    - Areas in which parts of motors with permanent magnets are being stored, operated, repaired or mounted.
  - ⇒ If it is necessary for a person with a pacemaker to enter such an area, then a physician must be consulted prior to doing so. Pacemakers, that are already implanted or will be implanted in the future, have a considerable deviation in their resistance to interference. Due to the unpredictable behavior there are no rules with general validity.
  - ⇒ Persons with hearing aids, metal implants or metal pieces must consult a doctor before they enter the areas described above. Otherwise health hazards will occur.
-

### 3.9 Protection against contact with hot parts

---



CAUTION

**Housing surfaces could be extremely hot!  
Danger of injury! Danger of burns!**

- ⇒ Do not touch surfaces near the source of heat! Danger of burns!
  - ⇒ Wait ten (10) minutes before you access any hot unit. Allow the unit to cool down.
  - ⇒ Do not touch hot parts of the equipment, such as housings, heatsinks or resistors. Danger of burns!
- 

### 3.10 Protection during handling and installation

Under certain conditions inappropriate handling and installation of parts and components may cause injuries.

---



CAUTION

**Risk of injury through incorrect handling!  
Bodily harm caused by crushing, shearing,  
cutting and mechanical shock!**

- ⇒ Observe general instructions and safety regulations during handling installation.
  - ⇒ Use only appropriate lifting or moving equipment.
  - ⇒ Take precautions to avoid pinching and crushing.
  - ⇒ Use only appropriate tools. If specified by the product documentation, special tools must be used.
  - ⇒ Use lifting devices and tools correctly and safely.
  - ⇒ Wear appropriate protective clothing, e.g. safety glasses, safety shoes and safety gloves.
  - ⇒ Never stay under suspended loads.
  - ⇒ Clean up liquids from the floor immediately to prevent personnel from slipping.
-

## 3.11 Battery safety

Batteries contain reactive chemicals in a solid housing. Inappropriate handling may result in injuries or equipment damage.



**CAUTION**

### **Risk of injury through incorrect handling!**

- ⇒ Do not attempt to reactivate discharged batteries by heating or other methods (danger of explosion and corrosion).
- ⇒ Never charge batteries (danger from leakage and explosion).
- ⇒ Never throw batteries into a fire.
- ⇒ Do not dismantle batteries.
- ⇒ Handle with care. Incorrect extraction or installation of a battery can damage equipment.

**Note:** Environmental protection and disposal! The batteries contained in the product should be considered as hazardous material for land, air and sea transport in the sense of the legal requirements (danger of explosion). Dispose batteries separately from other refuse. Observe the legal requirements given in the country of installation.

## 3.12 Protection against pressurized Systems

Certain Motors (ADS, ADM, 1MB etc.) and drives, corresponding to the information in the Project Planning manual, must be provided with and remain under a forced load such as compressed air, hydraulic oil, cooling fluid or coolant. In these cases, improper handling of the supply of the pressurized systems or connections of the fluid or air under pressure can lead to injuries or accidents.



**CAUTION**

### **Danger of injury when pressurized systems are handled by untrained personnel!**

- ⇒ Do not attempt to disassemble, to open or to cut a pressurized system.
- ⇒ Observe the operation restrictions of the respective manufacturer.
- ⇒ Before the disassembly of pressurized systems, lower pressure and drain off the fluid or gas.
- ⇒ Use suitable protective clothing (for example protective eyewear, safety shoes and gloves)
- ⇒ Remove any fluid that has leaked out onto the floor immediately.

**Note:** Environmental protection and disposal! The fluids used in the operation of the pressurized system equipment is not environmentally compatible. Fluid that is damaging to the environment must be disposed of separate from normal waste. Observe the national specifications of the country of installation.

## 4 PROFIBUS Coupler R-IL PB BK

### 4.1 Presentation and Application

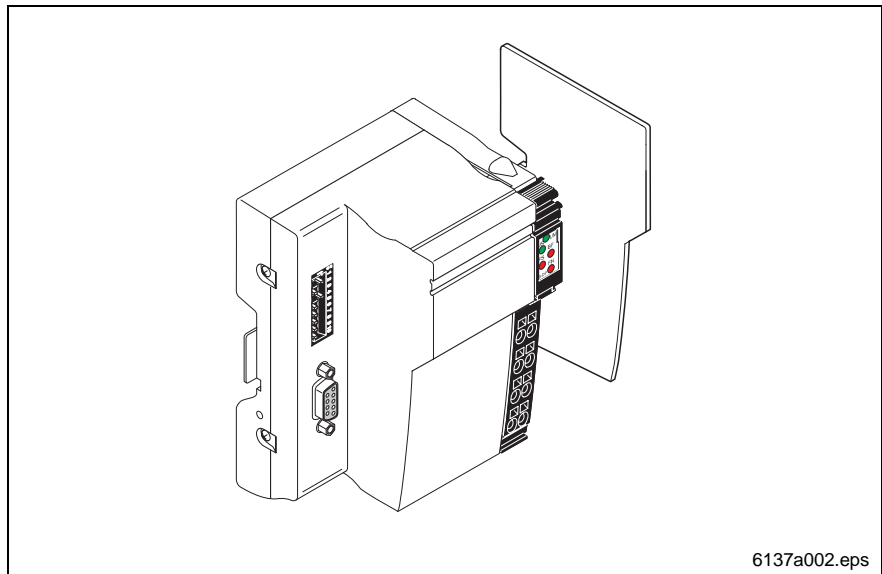

Fig. 4-1: Module R-IL PB BK with clipped-on connector and end plate

The PROFIBUS coupler constitutes the link between the PROFIBUS DP and the RECO Inline installation system.

At an existing PROFIBUS DP, you can connect Inline modules by means of the PROFIBUS coupler at any location. In this way, you'll be able to benefit from all advantages of the module-structured installation system with the PROFIBUS, too.

### Characteristics

The PROFIBUS coupler has the following characteristics:

- A maximum of 63 Inline modules can be connected to the PROFIBUS DP by simply latching them to each other via the coupler. Coupler and Inline module are one station.
- The total of input and output data of the connected modules may not exceed 192 bytes per station.
- You can use the coupler with a data transmission speed of 9,6 kBit/s up to 12 MBit/s. The coupler automatically adjusts to the speed set for the PROFIBUS master.
- The working voltage of the coupler is 24 V DC; the range of operating temperature is 0 °C to 55 °C.
- Diagnosis is implemented locally via LEDs both on the coupler and on the Inline and loop-2 modules. Moreover, the PROFIBUS is also used to transmit all diagnosis information to the PROFIBUS master.

Because of the intelligent wiring technology of the RECO Inline modules, the stations can be set up easily and quickly because, for instance, the extensive wiring for supplying the modules with voltage is not applicable any longer. In the easiest case, only the power supply units integrated in the PROFIBUS coupler must be supplied with 24 V DC voltage on their input side. They produce the necessary operation voltages for the PROFIBUS coupler and the connected Inline modules.

---

**Note:** The connector is not included in the scope of supply of the module. Please order the connector according to the ordering information.

---

The end plate is enclosed with the PROFIBUS DP fieldbus coupler. Place this plate as end cover of the Inline station. This plate does not have any electrical function. It protects the station from ESD pulses and the user from dangerous contact voltage.

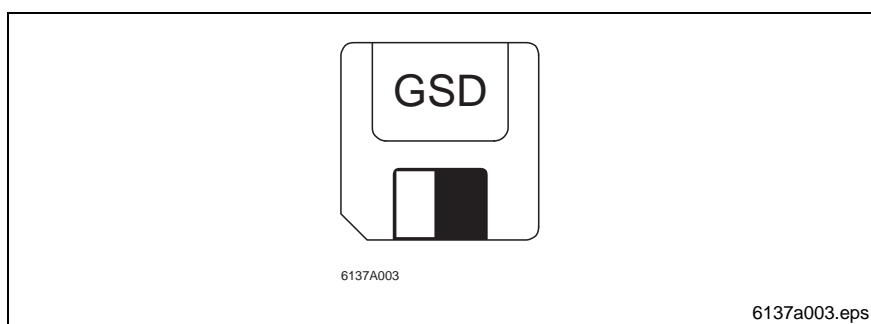

Fig. 4-2: Diskette with device master data file (GSD)

A disc is enclosed with the PROFIBUS DP fieldbus coupler. It contains the GSD file required for the PROFIBUS and a bitmap file with an icon of the coupler with lined-up Inline modules.

## Display elements

### Position of the diagnostic indicators

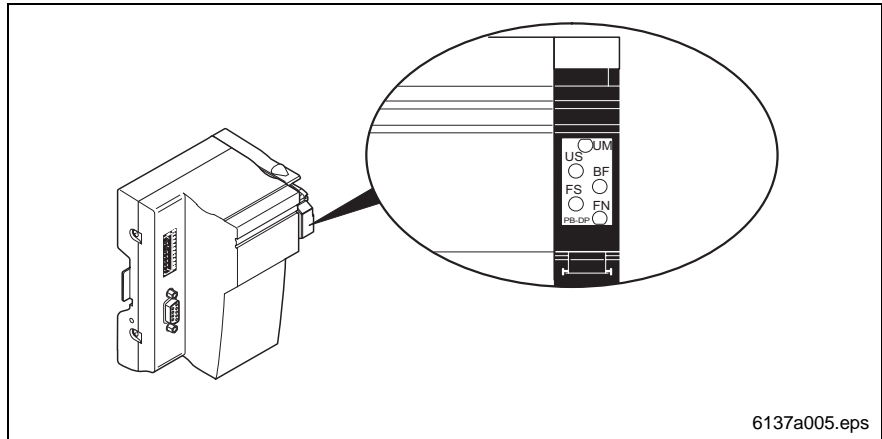

Fig. 4-3: Position of the diagnostic indicators R-IL PB BK

### Meaning of the diagnostic indicators

LED	Color	Meaning	State	Description of LED states
UM	Green	U <sub>Main</sub>	On	24 V supply of the main circuit available
			Off	Main circuit supply not available
US	Green	U <sub>Segment</sub>	On	24 V supply of the segment circuit available
			Off	Segment circuit supply not available
BF	Red	Bus Fault	On	No data exchange on the PROFIBUS
			Off	No failure
FS	Red	Failure Select	On	If FS is lit, FN indicates the failure type
			Off	If FS is dark, FN indicates the failure number
FN	Red	Failure Number	Flashing	The number of flashing pulses indicates the failure type or the failure number, depending on whether FS is lit or not.
			Off	No failure

Fig. 4-4: Meaning of the diagnostic indicators R-IL PB BK

## Standard and device-defined diagnosis for each PROFIBUS

Failure type	Meaning
1	Parameter failures on the PROFIBUS (SET_PRM telegram)
2	Configuration errors on the PROFIBUS (CHK_CFG telegram)
	Detailed information on configuration error on the PROFIBUS are indicated in 11 different error numbers.
3	Configuration errors in the RECO Inline station
	Detailed information on configuration error on the RECO Inline station are indicated in 7 different error numbers.
4	Local bus error within the station
	Detailed information on local bus error within the station are indicated in 6 different error numbers.
5	Module failure

Fig. 4-5: Diagnosis for each PROFIBUS

## 4.2 Connection of the PROFIBUS

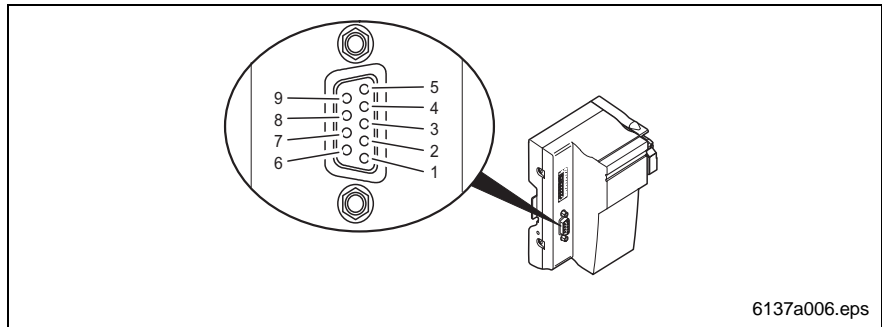

Fig. 4-6: PIN assignment of the 9-pin SUB-D connection socket

Connect the PROFIBUS to the fieldbus coupler via a 9-pin Sub-D connector. Refer to the following table for the PIN assignment.

PIN	Assignment
1	Reserved
2	Reserved
3	RxD / TxD-P (receiver/ Transmitter data +), line B
4	CNTR-P (control signal for repeater), directional control
5	DGND (reference potential to 5 V)
6	VP (supply voltage +5 V for termination resistors)
7	Reserved
8	RxD / TxD-N (receiver/transmitter data -), line B
9	Reserved

Fig. 4-7: PIN assignment R-IL PB BK

### Feed in operating voltages

Terminal points	Remark
1.1, 2.1	Segment supply voltage (+24 V DC)
1.2, 2.2	Main, fieldbus coupler, logic, and interface supply (+24 V DC)
1.3, 2.3	Reference potential
1.4, 2.4	Functional earth ground (FE)

Fig. 4-8: Feed in operation voltages R-IL PB BK

Connect the fieldbus coupler according to Fig. 4-9. For the terminal assignment of the fieldbus coupler, refer to Fig 4-7.

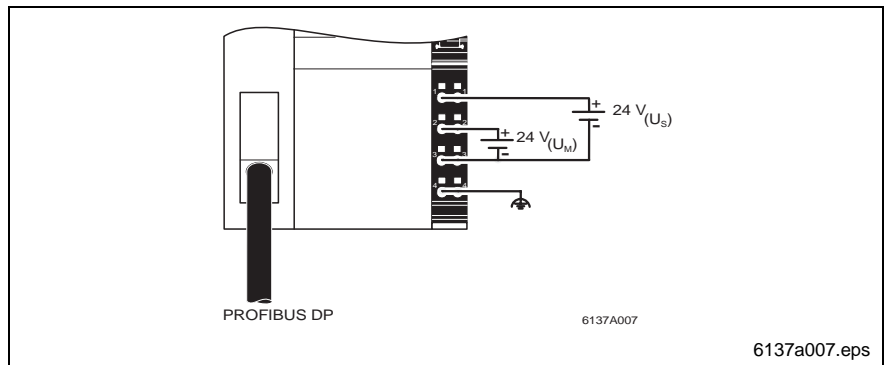

Fig. 4-9: Connector diagram of the PROFIBUS coupler R-IL PB BK

## Configuring the hardware

Configure the hardware at the PROFIBUS coupler using the 10-fold DIP switch.

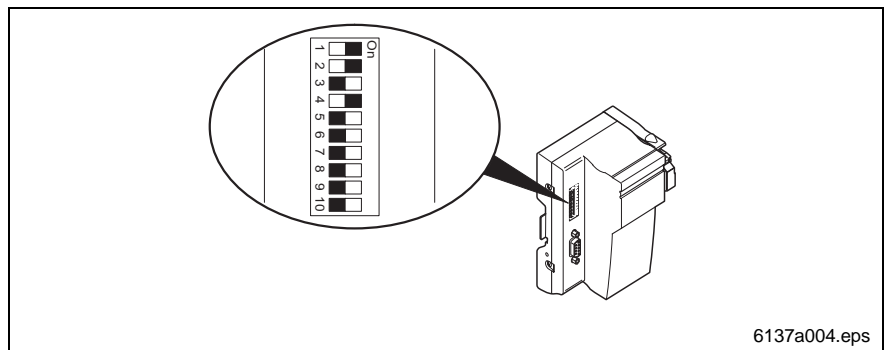

Fig. 4-10: DI switch of the PROFIBUS coupler

Using the 10-fold DIP switch, you can set the PROFIBUS address and further behaviors of PROFIBUS coupler. For the meaning of the switches please refer to the following figure.

DIP switches	Meaning
1 to 7	PROFIBUS address in binary representation (= 0-127 in decimal representation); switch 1 defines the least significant bit ( $2^0$ ), switch 7 the most significant bit ( $2^6$ ).
8	Behavior in case of data errors in the Inline station (local bus error): ON = data transfer stopped after a number of attempts OFF = the station permanently attempts to restart data transfer
9 to 10	Reserved; the switches <b>must</b> both be set to "OFF".

Fig. 4-11: Meaning of the DIP switches

---

**Note:** If DIP switch 8 is set to ON, a POWER DOWN/POWER UP must be implemented on the fieldbus coupler to restart the latter. In other word, there is no **automatic** restart after the error has been eliminated.

---

## System termination resistors

Since the PROFIBUS is a serial bus system with star-tree structure, the individual branches must be terminated with a termination resistor. The PROFIBUS coupler itself is not provided with such a resistor.

For further information please refer to your PROFIBUS documents. Rexroth Indramat recommends to use a special PROFIBUS connector (mat. no. 279788). This connector is provided with a connectable termination resistor.

### 4.3 Permissible RECO Inline devices

The following table contains a list of all Inline modules that can presently be operated with the PROFIBUS DP fieldbus coupler, together with their article numbers and descriptions as well as their significant properties.

Art. Identification	Art. no.	ID code dec/hex	Length dec/hex	IN adr.	OUT adr.	PCP	Reg. length	Error message	Current consumption	
									U <sub>L</sub>	U <sub>ANA</sub>
<b>Digital inputs</b>										
R-IB IL 24 DI 2	289286	190 / BE	194 / C2	2 bits	–	–	2 bits	–	35 mA	–
R-IB IL 24 DI 4	289287	190 / BE	65 / 41	4 bits	–	–	4 bits	–	40 mA	–
R-IB IL 24 DI 8	289288	190 / BE	129 / 81	1 byte	–	–	1 byte	–	50 mA	–
R-IB IL 24 DI 16	289290	190 / BE	01 / 01	2 bytes	–	–	2 bytes	–	60 mA	–
R-IB IL 24 DO 2-2A	289294	189 / BD	194 / C2	–	2 bits	–	2 bits	K, Ü	35 mA	–
R-IB IL 24 DO 4	289295	189 / BD	65 / 41	–	4 bits	–	4 bits	K, Ü	40 mA	–
R-IB IL 24 DO 8	289297	189 / BD	129 / 81	–	1 byte	–	1 byte	K, Ü	60 mA	–
R-IB IL 24 DO 16	289299	189 / BD	01 / 01	–	2 bytes	–	2 bytes	K, Ü	90 mA	–
R-IB IL 24/130 DOR 1W	289301	189 / BD	194 / C2	–	2 bits	–	2 bits	–	60 mA	–
<b>Analog inputs</b>										
R-IB IL AI 2/SF	289306	127 / 7F	02 / 02	4 bytes	4 bytes	–	4 bytes	L, P	38 mA	15 mA
R-IB IL TEMP 2 RTD	289305	127 / 7F	02 / 02	4 bytes	4 bytes	–	4 bytes	D	43 mA	11 mA
<b>Analog outputs</b>										
R-IB IL AO 1/SF	289303	125 / 7D	01 / 01	–	2 bytes	–	2 bytes	L	35 mA	25 mA
R-IB IL AO 2/U/BP	289381	91 / 5B	02 / 02	4 bytes	4 bytes	–	4 bytes	L	35 mA	25 mA
<b>Function modules *)</b>										
R-IB IL CNT	289315	191 / BF	02 / 02	4 bytes	4 bytes	–	4 bytes	K, A	40 mA	–
<b>Supply terminals</b>										
R-IB IL 24 PWR IN	289312	–	–	–	–	–	–	–	–	–
R-IB IL 24 SEG/F	289313	–	–	–	–	–	–	–	–	–

Fig. 4-12: Permissible INTERBUS Inline devices

\*) in preparation

The abbreviations in the "Error message" column are explained in Fig. 4-13.

### Explanation of the error messages

Abbreviation	Meaning
K	signals a short-circuit or an overload of an output and/or an initiator supply voltage
A	signals a failure of the main or the segment voltage or the sensor supply of the loop
P	signals an overload of an output
Ü	signals a failure of the internal supply voltage
D	signals a wire break during TC operation
L	signals that the logic voltage UL has failed or has fallen below

Fig. 4-13: Explanation of error messages with INTERBUS devices

## 4.4 Technical Data

### General data

Article identification	PROFIBUS DP fieldbus coupler R-IL PB BK	
Article number	289283	
Article identification	Supply connector R-IB IL SCN-PWR IN-CP	
Article number	Supply connector 289337	
Housing dimensions	91 mm x 120 mm x 71.5 mm (W x H x D)	
Weight	210 g (without connector)	
Permissible temperature	Operation Storage/transport	0°C to +55 °C -25 °C to +85 °C
Air humidity	Operation Storage/transport	75 % on average, 85 % occasionally 75 % on average, 85 % occasionally
Atmospheric pressure	Operation Storage/transport	80 kPa to 106 kPa (up to 2000 m above MSL) 70 kPa to 106 kPa (up to 3000 m above MSL)
Degree of protection	IP20 according to IEC 60529	
Safety classification	Classification 3, according to VDE 0106, IEC 60536	

Fig. 4-14: General technical data R-IL PB BK

### System data

Number of devices per station	No more than 63
Total of all I/O data per station	Maximum 192 bytes
Maximum current of the fieldbus coupler to supply the logic system of the I/O module	2 A to $U_L$
Maximum additional current to supply the analog module	0,5 A to $U_{ANA}$

Fig. 4-15: System data R-IL PB BK

### PROFIBUS DP Interface

Copper line (RS 485), connected via a SUB-D shield connector; electrically isolated supply; shield directly connected to the functional earth ground.

Fig. 4-16: PROFIBUS DP Interface

## Data of the voltage supply

24 V main incoming supply $U_M$ / 24 V segment incoming supply $U_S$	
Connection method	Tension spring terminals
Recommended cable lengths	No more than 30m; cable routing across exposed areas impermissible
Transmission	Via voltage routing
Nominal value	24 V DC
Tolerance	-15 % / +20% (according to EN 61131-2)
Ripple factor	± 5%
Permissible range	19.2 V to 30 V (including ripple factor)
Minimum power consumption at nominal voltage (main incoming supply)	0,1 A DC (in case of no-load operation, i.e. incoming PROFIBUS clipped on, no Inline devices connected)
Maximum power consumption at nominal voltage	1.25 A DC, consisting of: 0,75 A DC for logics supply 0,5 A DC for analog voltage supply
Safety measures Overvoltage polarity reversal	Yes Yes

Fig. 4-17: 24 V main incoming supply / 24 V segment incoming supply



### Protect the 24 V range with an external fuse!

⇒ The 24 V range must be protected with an external fuse. The power supply unit must be able to deliver the quadruple nominal current of the external fusible cutout, to ensure that the fuse is safely tripped in case of a failure.

## Compliance with the EMC Guideline 89/336/EEC

<b>Immunity test according to EN 50082-2</b>		
Discharge of static electricity (ESD)	EN 61000-4-2 / IEC 61000-4-2	Criterion B 6 kV contact discharge 8 kV air discharge
Electromagnetic fields	EN 61000-4-3 / IEC 61000-4-3	Criterion A Field strength: 10 V/m
Fast transients (burst)	EN 61000-4-4 / IEC 61000-4-4	Criterion A All interfaces: 1 kV
Transient overvoltage (surge)	EN 61000-4-5 / IEC 61000-4-5	Criterion B DC supply lines: 0.5 kV/1 kV (symmetrical/asymmetrical) Fieldbus cable shield
Conducted disturbances	EN 61000-4-6 / IEC 61000-4-6	Criterion A Test voltage 10 V
<b>Noise radiation test according to EN 50081-2</b>		
Interference emitted by the housing	EN 55011	Class A

Fig. 4-18: Correspondence with ECM regulation 89/336/EEC R-IL PB BK

## 5 Power terminal IB IL 24 PWR IN

### 5.1 Representation and Description of Application

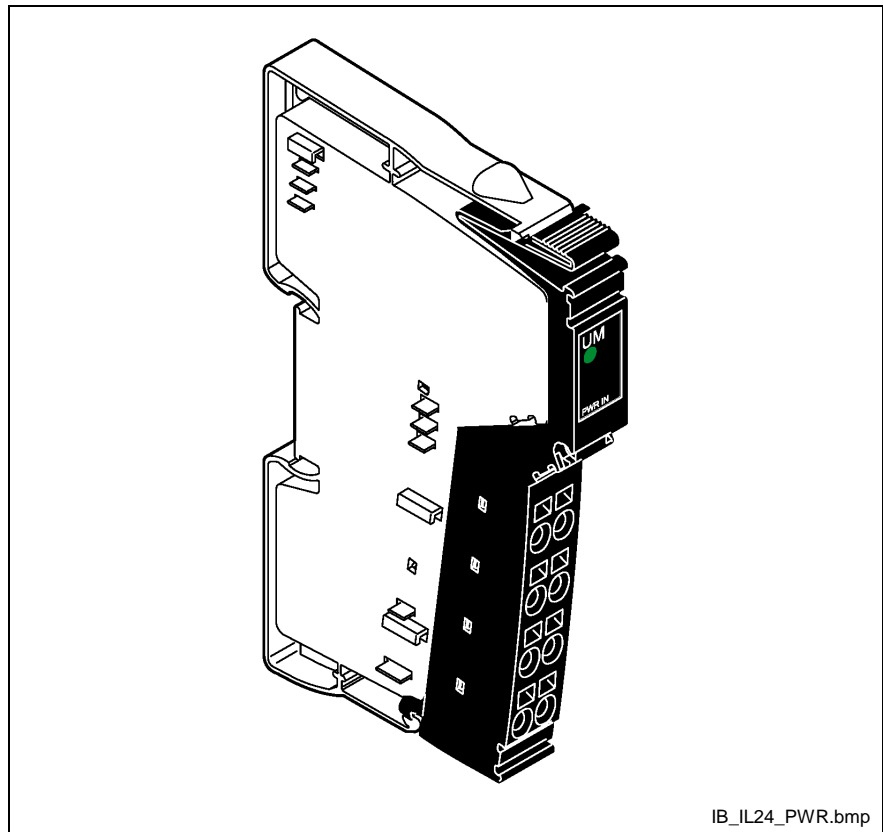

Fig. 5-1: The terminal R-IB IL 24 PWR IN with clipped-on connector

The terminal allows to feed the supply voltages into the main circuit. Additionally, the supply for a segment circuit can be provided at this terminal.

### Characteristics

- Supply of the main voltage
- Supply/provision of the segment voltage
- Protection of the main circuit via an external fuse
- Protection of the segment circuit via an external fuse is possible
- Diagnostic indication

---

**Note:** This terminal does not have a protocol chip; accordingly, it is no bus device.

---

## Indication elements

### Position of the diagnosis indication

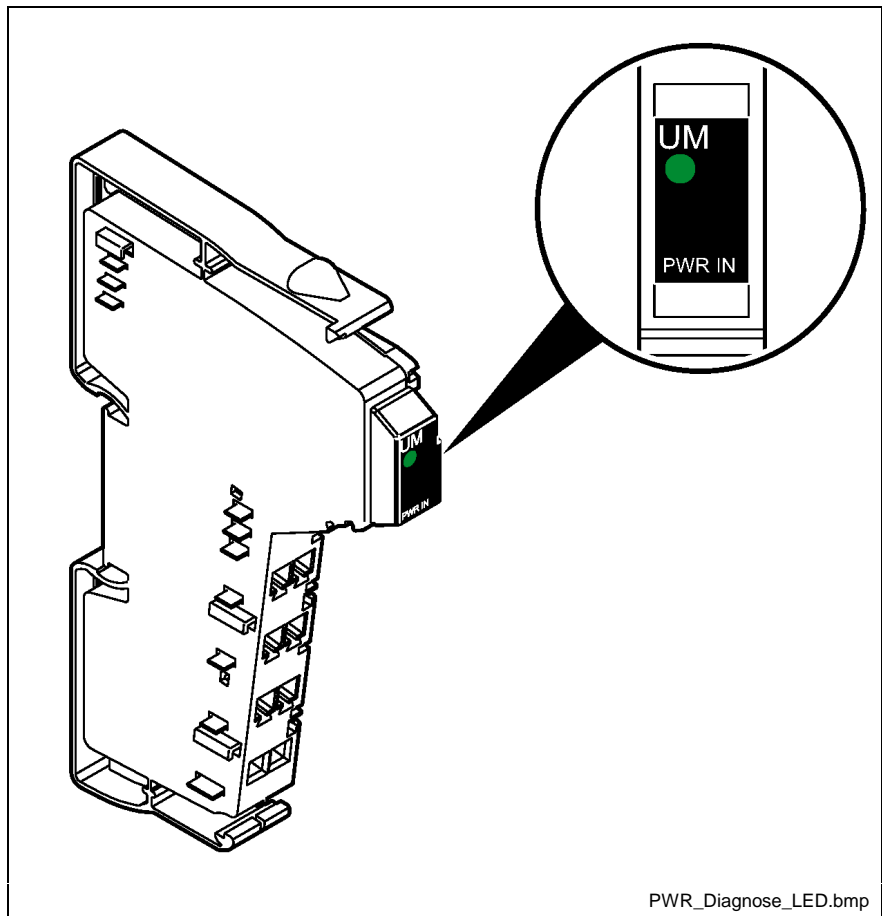

Fig. 5-2: Position of the diagnosis display element R-IB IL 24 PWR IN

### Meaning of the diagnosis display elements

Identification	Color	Meaning
UM	Green	24 V voltage (in the main circuit $U_M$ )

Fig. 5-3: Meaning of the diagnosis display elements R-IB IL 24 PWR IN

## 5.2 Technical data

General Notes		
Housing dimensions	12,2 x 120 x 71.5 mm (W x H x D)	
Weight	44 g (without connector)	
Permissible temperature	Operation Storage/transport	-25°C to +55 °C -25 °C to +85 °C
Air humidity	Operation Storage/transport	5 % to 90 %, dew formation not permissible 5 % to 95 %, dew formation not permissible
Atmospheric pressure	Operation Storage/transport	80 kPa to 106 kPa (up to 2000 m above MSL) 70 kPa to 106 kPa (up to 3000 m above MSL)
Degree of protection	IP20 according to IEC 60529	
Safety classification	Classification 3, according to VDE 0106, IEC 60536	

Fig. 5-4: General technical data R-IB IL 24 PWR IN

24 V peripheral supply	
Connection	+ 24 V ground
Connecting points	1.2 and 2.2 connecting points 1.3 and 2.3
Rated value	24 V DC
Tolerance	-15 % / +20 % (according to EN 61131-2)
A.C, component	5 %
Permissible range	19.2 V to 30 V (including ripple factor)
Permissible current	Max. 8 A
Requirements in the voltage supply	If an isolated area is to be set up, the power terminals must be supplied from a new power supply unit. The 24 V area is to be protected with an external fuse.

Fig. 5-5: Data of the 24 V peripheral supply

---

**Note:** The power supply unit must be able to deliver the quadruple nominal current of the external fuse.

---

Protective devices	
Overload/short-circuit in the segment circuit	No
Overvoltage	Yes Suppressor diode to limit the voltage between the connecting points 1.1 and 1.3 and between the connecting points 1.2 and 1.3
Reversed polarity	Yes

Fig. 5-6: Protective devices R-IB IL 24 PWR IN

---

**Note:** The power supply unit must be able to deliver the quadruple nominal current of the external fuse.

---

## 5.3 Connections

### Position of the terminals

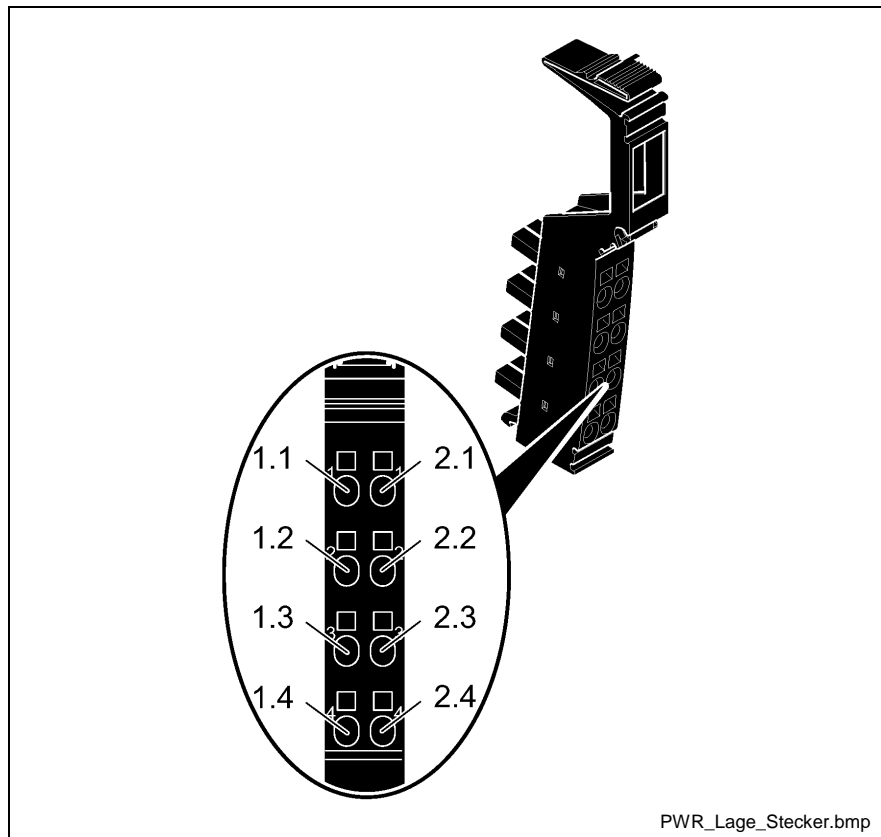

Fig. 5-7: Position of the terminals R-IB IL 24 PWR IN

### Terminal assignment

Terminal point	Assignment
1.1, 2.1	Supply point for the segment circuit $U_S$ (+24 V); connection of a connector or a bridge in the segment level.
1.2, 2.2	Supply point for the main circuit $U_M$ (Main Circuit; +24 V). Connection of a connector or a bridge in the segment level. These connecting points are connected to each other and unilaterally with the voltage jumper of the unprotected main supply $U_M$ . The voltage jumper of the unprotected main circuit $U_M$ and the segment circuit $U_S$ together are equipped with the load capacity 8 A.
1.3, 2.3	Bonding to frame (GND) The reference potential is directly transferred to the voltage jumpers and serves simultaneously as ground reference for the peripheral and segment voltage.
1.4, 2.4	FE connection The contacts are directly connected to the voltage jumpers and the FE spring at the bottom of the housing. On latching onto a grounded mounting rail, the terminal is grounded.
	The terminal points 1.1, 1.2 and 1.3 are capacitively connected to FE.

Fig. 5-8: Terminal assignment R-IB IL 24PWR IN

**Note:** The maximum total current capacity through the voltage jumpers modules is 8A.

### Internal block diagram

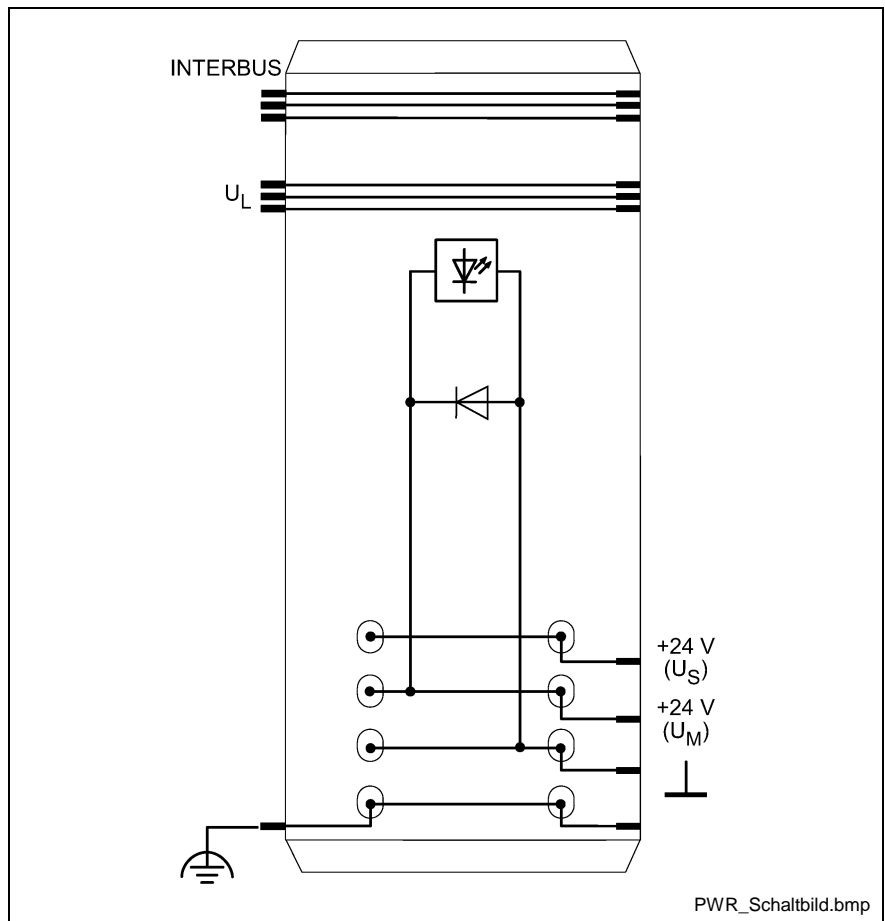

Fig. 5-9: Internal protective elements of the terminal points R-IB IL 24 PWR IN

### Explanation of the symbols



Symbol	Explanation
	LED
	Diode

Fig. 5-10: Explanation of the symbols

## Example of a connection

**Note:** The 24 V supply must be protected via an external fuse!

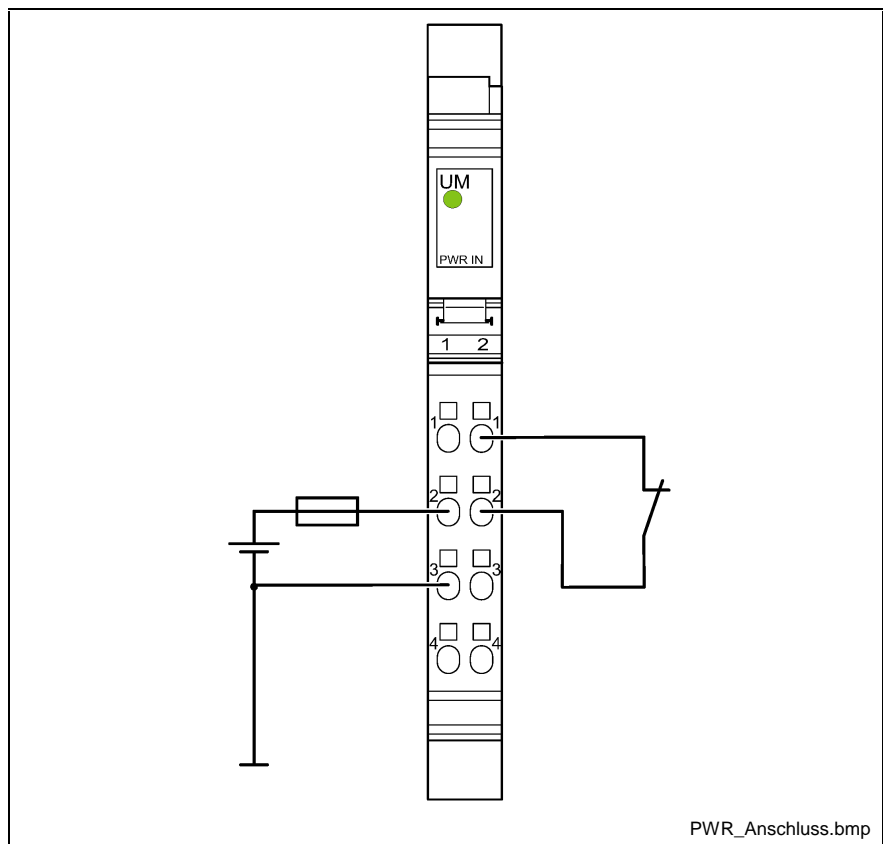

Fig. 5-11: Connection of the supply voltage and an external connector

**Note:** A switched segment circuit can be set up by means of the connector.

If this is not necessary in an individual application, the segment voltage can be provided by one of the following alternatives:

1. Setting up of a bridge between the connections 1.1 (2.1) and 1.2 (2.2).
2. Separate feeding of the segment voltage.
3. Using an additional segment terminal.

## 5.4 Electrical isolation

---

**Note:** For the electrical isolation of the logics level from the peripheral area, these areas must be supplied from different power supply units via the bus terminal or via the bus terminal and a power terminal. The supply devices must not be connected in the 24 V area! Make sure that GND-PE connections are available at the supply devices!

---

### Common potentials

24 V main voltage, 24 V segment voltage, and GND lie on the same potential. FE is a potential area of its own.

### Isolated potentials

The following table shows the potentials of a combination of bus terminal, power terminal and I/O terminal:

Test section	Test voltage
5 V supply of incoming remote bus / 7.5 V supply (bus logics)	500 V AC, 50 Hz, 1 min.
5 V supply of next remote bus / 7.5 V supply (bus logics)	
7.5 V supply (bus logics) / 24 V supply (peripheral system)	
24 V supply (peripheral system) / functional earth	

Fig. 5-12: Test section R-IB IL 24 PWR IN / R-IB IL 24 SEG/F



## 6 Segment Terminal R-IB IL 24 SEG/F

### 6.1 Representation and Description of Application

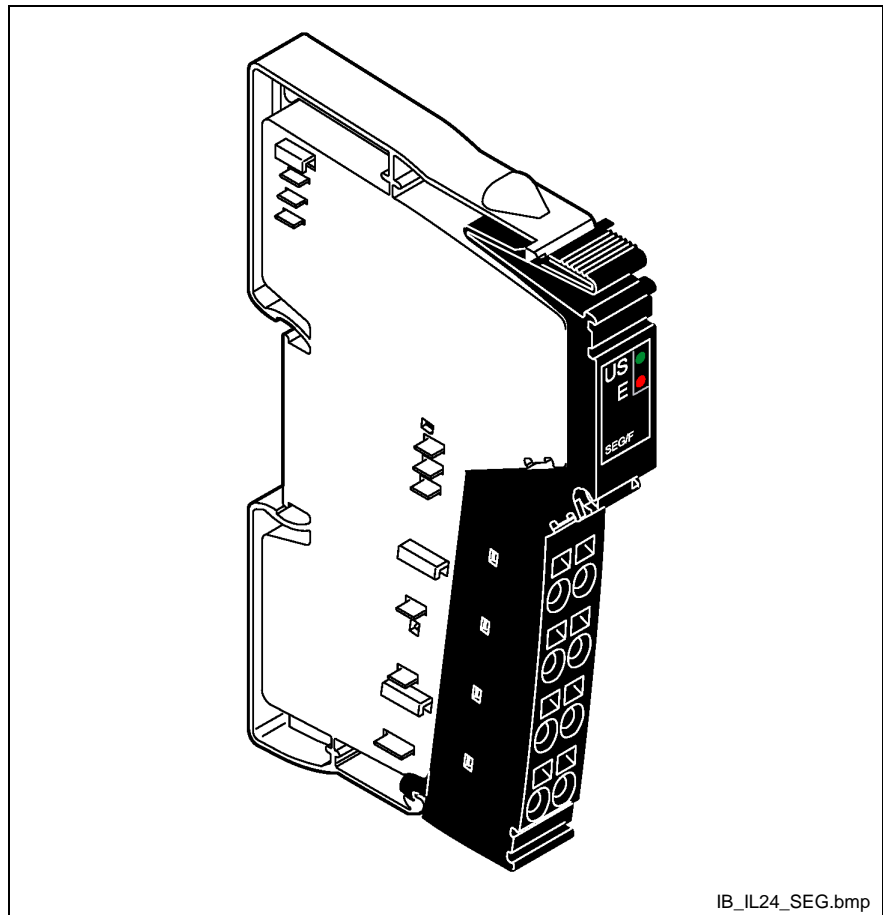

Fig. 6-1: The terminal R-IB IL 24 SEG/F with clipped-on connector

The terminal allows for setup of a protected partial circuit (segment circuit) within the main circuit. It does not feed in voltage, and accordingly is not equipped with reverse voltage and overvoltage protection components.

### Characteristics

- Automatic setup of a partial circuit within the main circuit.
- Protection of the segment circuit via an internal fuse.
- Diagnosis indication

---

**Note:** This terminal does not have a protocol chip; accordingly, it is no bus device.

---

## Display elements

### Position of the diagnosis display elements

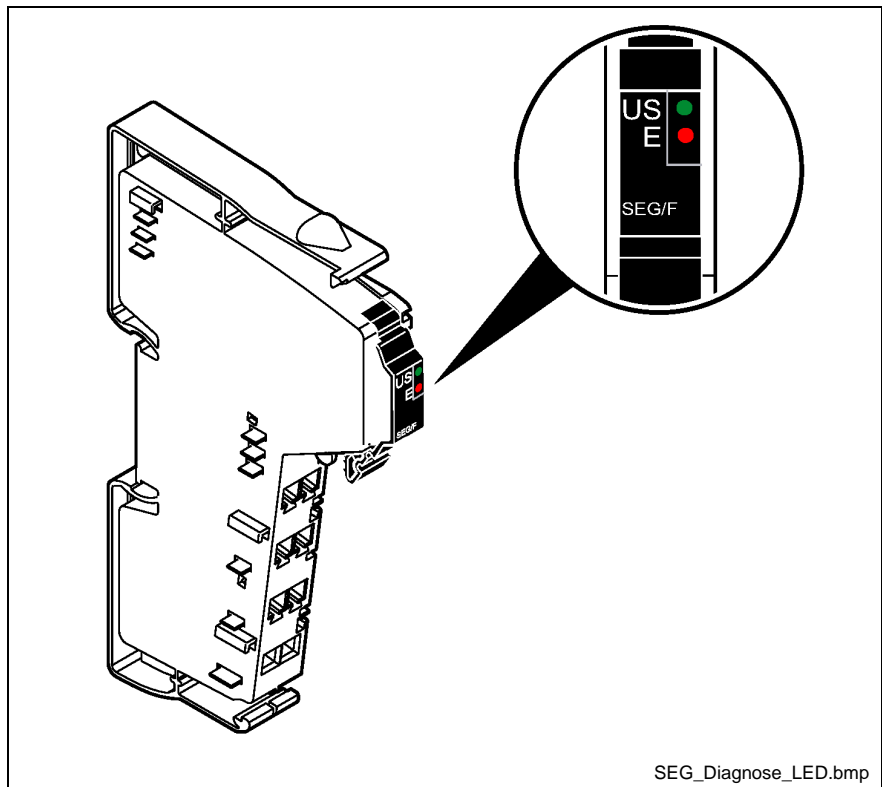

Fig. 6-2: Position of the diagnosis display elements R-IB IL 24 SEG/F

### Meaning of the diagnosis display elements

Identification	Color	Meaning
US	Green	24 v voltage (in the segment circuit $U_S$ ; before the fuse)
E	Red	Protection of the segment terminal (in the segment circuit $U_S$ )

Fig. 6-3: Meaning of the diagnosis indications

## 6.2 Technical data

General Notes		
Housing dimensions	12,2 x 120 x 71.5 mm (W x H x D)	
Weight	44 g (without connector)	
Permissible temperature	Operation Storage/transport	-25°C to +55 °C -25 °C to +85 °C
Air humidity	Operation Storage/transport	5 % to 90 %, no dew formation 5 % to 90 %, no dew formation
Atmospheric pressure	Operation Storage/transport	80 kPa to 106 kPa (up to 2000 m above MSL) 70 kPa to 106 kPa (up to 3000 m above MSL)
Degree of protection	IP20 according to IEC 60529	
Safety classification	Classification 3, according to VDE 0106, IEC 60536	

Fig. 6-4: General technical data R-IB IL 24 PWR IN

**Note:** Voltage is supplied in the bus terminal or in the power terminal. At the segment terminal, no connections for supply voltage are required. The respective terminals are available for test purposes.

Permissible total current in the voltage jumpers of the main and segment circuit	
Nominal current of the terminal	6.0 A
Maximum permissible value	8.0 A

Fig. 6-5: Permissible total current

**Note:** The terminal is supplied with a slow 6.3 A fusible cutout. With higher crossover currents, the operator must provide for higher protection of the circuit.

Protective devices	
Overload/short-circuit in the segment circuit	5 x 20 fusible cutout with 6.3 A slow
Overvoltage	Protection elements in the power terminal or the bus terminal
Reversed polarity	Protection elements in the power terminal or the bus terminal

Fig. 6-6: Protective devices



**Note on the selection of fusible cutouts**

⇒ With fuses of more than 2 A, only slow fuses may be used!

## 6.3 Connections

### Position of the terminals

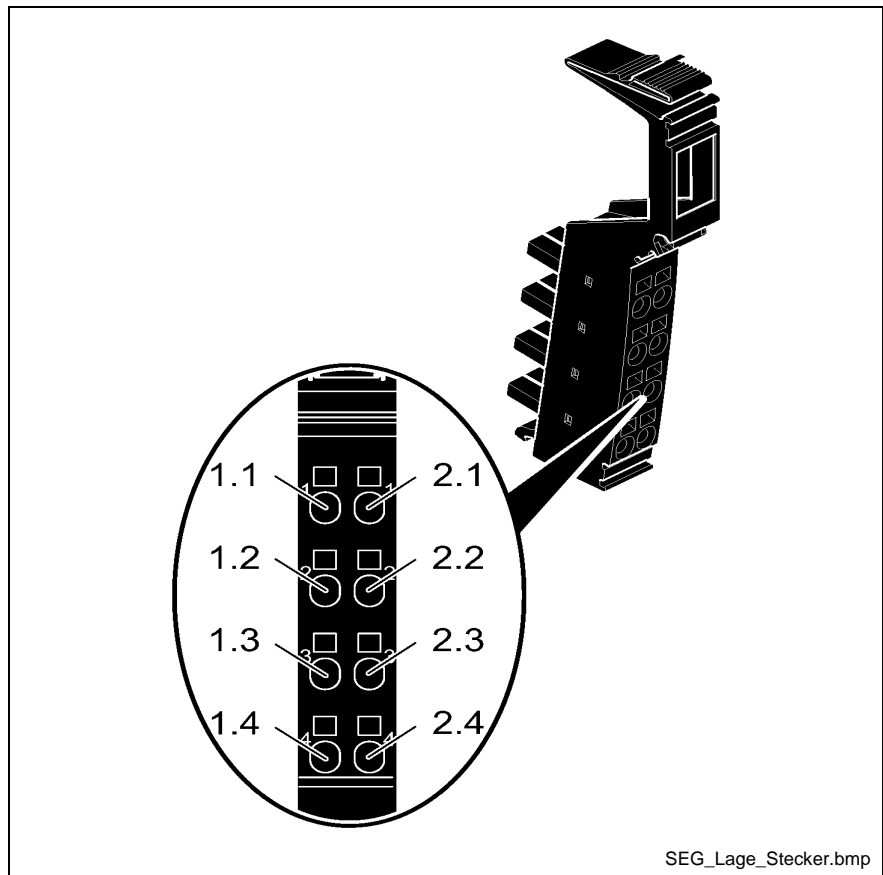

Fig. 6-7: Position of the terminals R-IB IL SEG/F

### Terminal assignment

Terminal	Signal
1.1, 2.1	Segment voltage $U_S$ (after fuse)
1.2, 2.2	Main voltage $U_M$
1.3, 2.3	GND of supply voltages
1.4, 2.4	FE connection

Fig. 6-8: Terminal assignment

### Internal block diagram

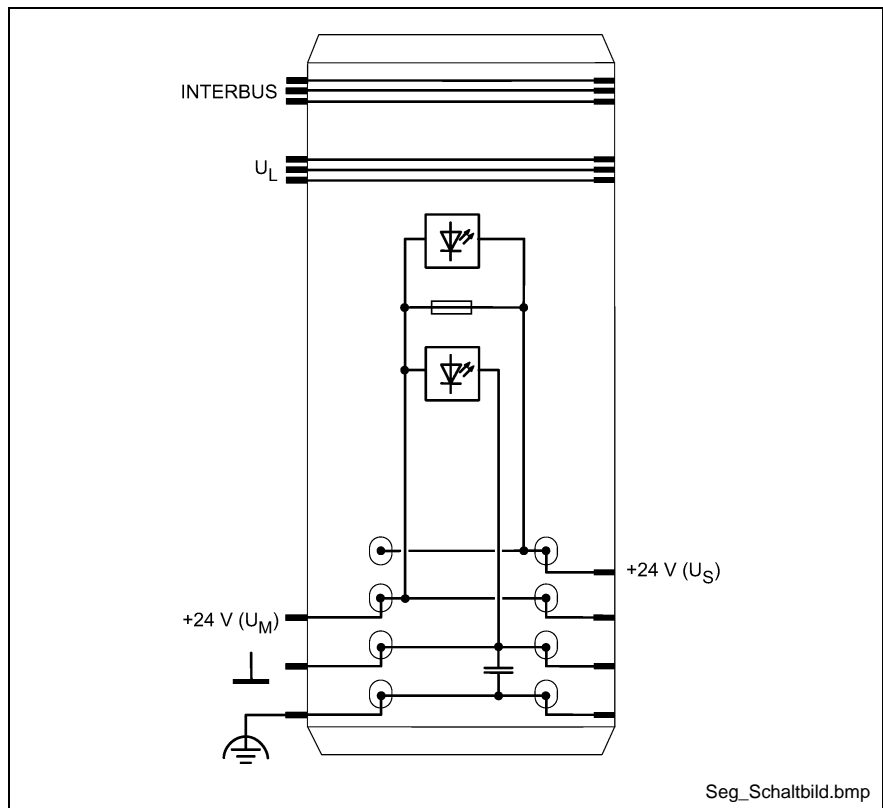

Fig. 6-9: Internal circuit elements of the terminal points

### Explanation of the symbols

Symbol	Explanation
	LED
	Fuse
	Capacitive connection to function earth (FE)

Fig. 6-10: Explanation of the symbols

## 6.4 Electrical isolation

---

**Note:** For the electrical isolation of the logics level from the peripheral area, these areas must be supplied from different power supply units via the bus terminal or via the bus terminal and a power terminal. The supply devices must not be connected in the 24 V area! Make sure that GND-PE connections are available at the supply devices!

---

### Common potentials

24 V main voltage, 24 V segment voltage, and GND lie on the same potential. FE is a potential area of its own.

### Isolated potentials

The following table shows the potentials of a combination of bus terminal, power terminal and I/O terminal:

Test section	Test voltage
5 V supply of incoming remote bus / 7.5 V supply (bus logics)	500 V AC, 50 Hz, 1 min.
5 V supply of next remote bus / 7.5 V supply (bus logics)	
7.5 V supply (bus logics) / 24 V supply (peripheral system)	
24 V supply (peripheral system) / functional earth	

Fig. 6-11: Test section R-IB IL 24 PWR IN / R-IB IL 24 SEG/F

## 6.5 Diagrams and formulas

### Derating

#### Load current in the segment circuit

Ambient temperature	Load current in segment circuit $I_s$
55°C	4.0 A
45°C	6.3 A

Fig. 6-12: Derating of the load current in the segment circuit

#### Load current as a function of the ambient temperature

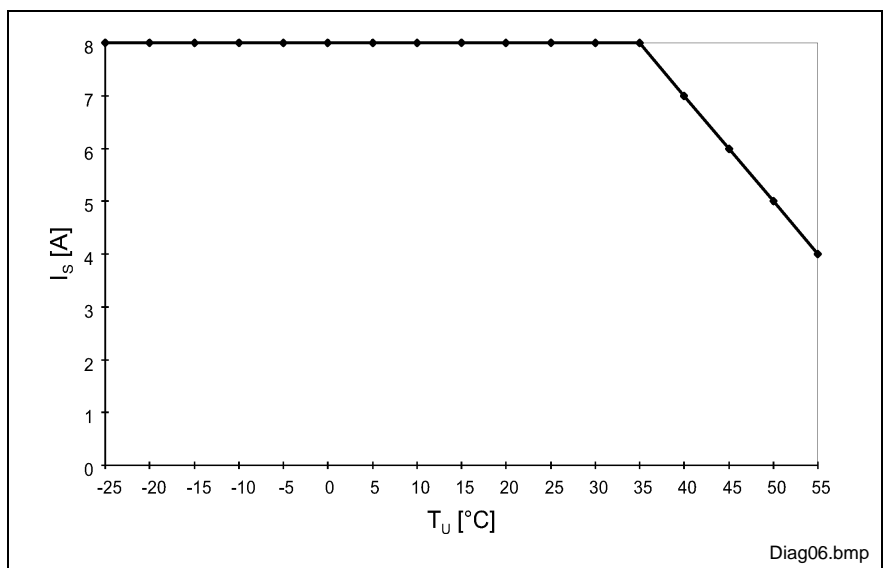

Fig. 6-13: Load current as a function of the ambient temperature

$I_s$  [A]                      Load current in the segment circuit in A  
 $T_U$  [°C]                     Ambient temperature in °C

### Voltage characteristics in the segment circuit in case of a fuse defect

**Note:** Even after tripping of the fusible cutout, the segment circuit is not dead! Observe characteristics!

Resistance ( $\Omega$ )	Typical output voltage (V)	Typical current (mA)
1000000	12,80	0,013
100000	12,21	0,122
10000	8,60	0,86
1000	1,99	1,99
100	0,28	2,8

Fig. 6-14: Voltage and current data as a function of the resistance values

### Output voltage as a function of the resistance value

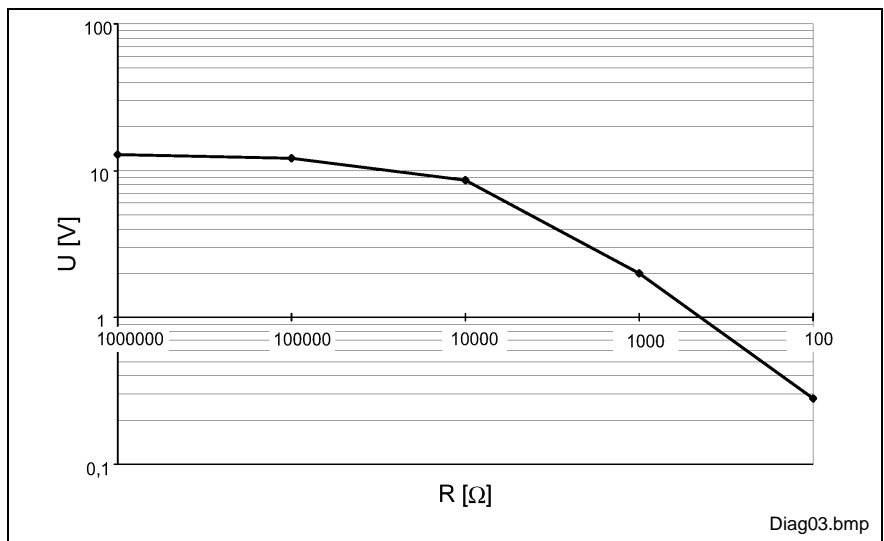

Fig. 6-15: Output voltage as a function of the resistance value

U [V] Output voltage in V

R [Ω] Resistance in Ω

### Output current as a function of the resistance value

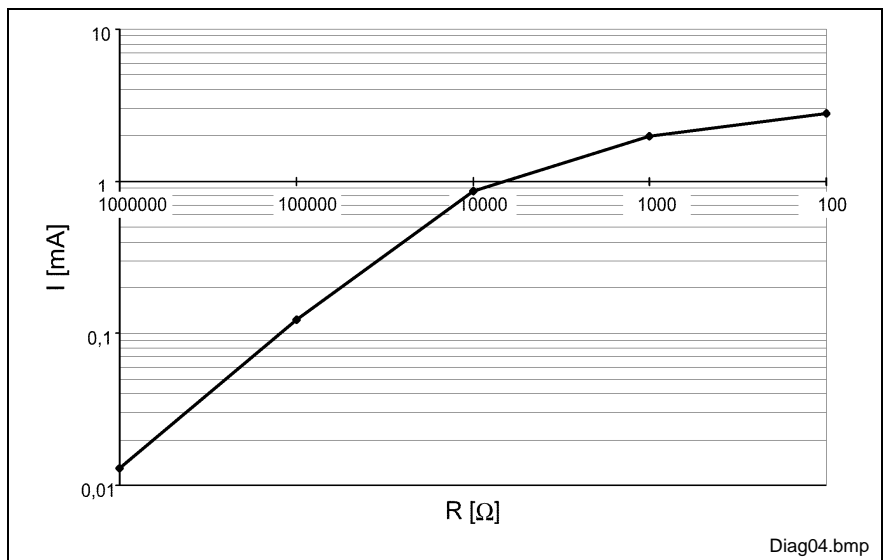

Fig. 6-16: Output current as a function of the resistance value

I [A] Output current in A

R [Ω] Resistance in Ω

## Power loss

Formula for the calculation of electronics power loss

$$P_{EL} = 0,180W + I_S^2 \times R_F$$

Abb. 6-17: Power loss P<sub>EL</sub> of the terminal R-IB IL 24 SEG/F

### Power loss of the housing as a function of the ambient temperature

$$P_{HOU} = 2,4W \quad \text{at } -25^\circ C < T_U \leq -5^\circ C$$

Abb. 6-18: Power loss of the housing sector 1

$$P_{HOU} = 2,4W - \frac{T_U - (-5^\circ C)}{37,5K / W} \quad \text{at } -5^\circ C < T_U \leq +55^\circ C$$

Abb. 6-19: Power loss of the housing sector 2

- It signifies**
- P<sub>EL</sub> Total power loss in the terminal
  - I<sub>S</sub> Load current in the segment circuit
  - R<sub>F</sub> Fuse resistance; the resistance of the fuse R<sub>F</sub> for a 6.3 AT fuse is approx. 50mΩ.
  - T<sub>U</sub> Ambient temperature

### Typical power loss as a function of the load current in the segment circuit

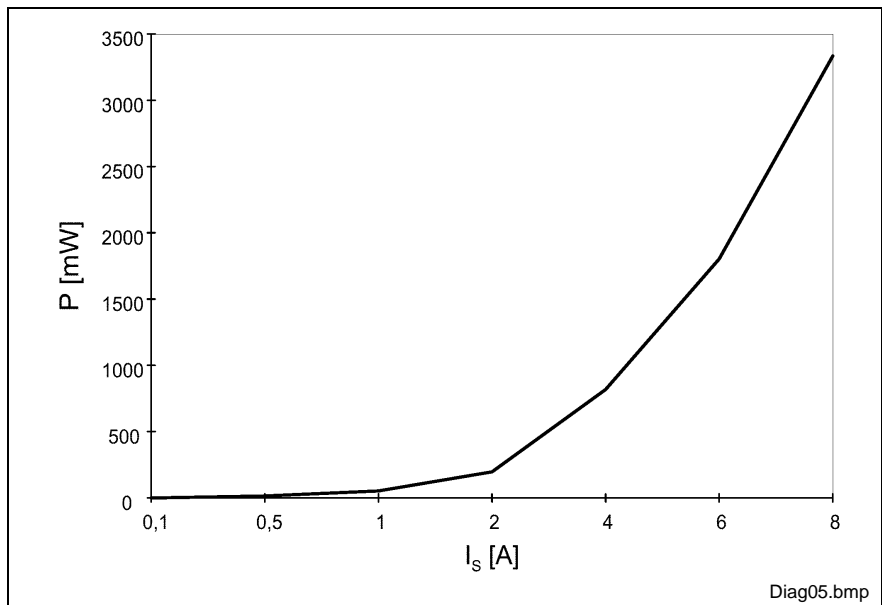

Fig. 6-20: Typical power loss as a function of the load current

- P [mW] Power loss in mW
- I<sub>S</sub> [A] Load current in the segment circuit in A



# 7 Order Information

## 7.1 Order identification

**Note:** With all modules, the connectors are not part of the scope of supply. They must be ordered separately.

Description	Short type (ordering information)	Material number
<b>PROFIBUS coupler</b>		
PROFIBUS coupler (including end plate and diskette with GSD file)	R-IL PB BK	289280
Supply connector for PROFIBUS coupler, neighboring terminal points bridged internally (black, printed) content of package: 10 pieces	R-IB IL SCN-PWR IN-CP	289328
<b>Supply terminals</b>		
Power terminal without fuse	R-IB IL 24 PWR IN	289312
Segment terminal with fuse	R-IB IL 24 SEG/F	289313
<b>Accessories</b>		
End support, included in the bus coupler's scope of supply	CLIPFIX 35	
Screw driver according to DIN 5264, blade width 3.5 mm (9/64 in.)	SZF 1 - 0,6 x 3,5	In preparation
Fuse 6.3 A slow	FUSE-F 6,300A 19195 SLOW	251957
Connector for voltage feed-in (black, printed) Content of package: 10 pieces	R-IB IL SCN-PWR IN-CP	289328
<b>Documentation</b>		
Description of application	DOK-CONTRL-R-IL*PBSSYS	289596

Fig. 7-1: Ordering information of the terminals and the accessories

Description	Short type (ordering information)	Material number
SUB-D connector, 9 poles, with two cable lead wires for PROFIBUS with 12 Mbits/s (matching resistor connectable via slide switch)	INS 0541	279788

Fig. 7-2: Order identification of Sub-D connectors



## 8 List of figures

- Fig. 1-1: Remote bus terminals and supply modules 1-1
- Fig. 3-1: Classes of danger with ANSI 3-3
- Fig. 4-1: Module R-IL PB BK with clipped-on connector and end plate 4-1
- Fig. 4-2: Diskette with device master data file (GSD) 4-2
- Fig. 4-3: Position of the diagnostic indicators R-IL PB BK 4-3
- Fig. 4-4: Meaning of the diagnostic indicators R-IL PB BK 4-3
- Fig. 4-5: Diagnosis for each PROFIBUS 4-4
- Fig. 4-6: PIN assignment of the 9-pin SUB-D connection socket 4-5
- Fig. 4-7: PIN assignment R-IL PB BK 4-5
- Fig. 4-8: Feed in operation voltages R-IL PB BK 4-5
- Fig. 4-9: Connector diagram of the PROFIBUS coupler R-IL PB BK 4-6
- Fig. 4-10: DI switch of the PROFIBUS coupler 4-6
- Fig. 4-11: Meaning of the DIP switches 4-7
- Fig. 4-12: Permissible INTERBUS Inline devices 4-8
- Fig. 4-13: Explanation of error messages with INTERBUS devices 4-9
- Fig. 4-14: General technical data R-IL PB BK 4-10
- Fig. 4-15: System data R-IL PB BK 4-10
- Fig. 4-16: PROFIBUS DP Interface 4-10
- Fig. 4-17: 24 V main incoming supply / 24 V segment incoming supply 4-11
- Fig. 4-18: Correspondence with ECM regulation 89/336/EEC R-IL PB BK 4-12
- Fig. 5-1: The terminal R-IB IL 24 PWR IN with clipped-on connector 5-1
- Fig. 5-2: Position of the diagnosis display element R-IB IL 24 PWR IN 5-2
- Fig. 5-3: Meaning of the diagnosis display elements R-IB IL 24 PWR IN 5-2
- Fig. 5-4: General technical data R-IB IL 24 PWR IN 5-3
- Fig. 5-5: Data of the 24 V peripheral supply 5-3
- Fig. 5-6: Protective devices R-IB IL 24 PWR IN 5-3
- Fig. 5-7: Position of the terminals R-IB IL 24 PWR IN 5-4
- Fig. 5-8: Terminal assignment R-IB IL 24PWR IN 5-4
- Fig. 5-9: Internal protective elements of the terminal points R-IB IL 24 PWR IN 5-5
- Fig. 5-10: Explanation of the symbols 5-5
- Fig. 5-11: Connection of the supply voltage and an external connector 5-6
- Fig. 5-12: Test section R-IB IL 24 PWR IN / R-IB IL 24 SEG/F 5-7
- Fig. 6-1: Th terminal R-IB IL 24 SEG/F with clipped-on connector 6-1
- Fig. 6-2: Position of the diagnosis display elements R-IB IL 24 SEG/F 6-2
- Fig. 6-3: Meaning of the diagnosis indications 6-2
- Fig. 6-4: General technical data R-IB IL 24 PWR IN 6-3
- Fig. 6-5: Permissible total current 6-3
- Fig. 6-6: Protective devices 6-3
- Fig. 6-7: Position of the terminals R-IB IL SEG/F 6-4

- Fig. 6-8: Terminal assignment 6-4
- Fig. 6-9: Internal circuit elements of the terminal points 6-5
- Fig. 6-10: Explanation of the symbols 6-5
- Fig. 6-11: Test section R-IB IL 24 PWR IN / R-IB IL 24 SEG/F 6-6
- Fig. 6-12: Derating of the load current in the segment circuit 6-7
- Fig. 6-13: Load current as a function of the ambient temperature 6-7
- Fig. 6-14: Voltage and current data as a function of the resistance values 6-7
- Fig. 6-15: Output voltage as a function of the resistance value 6-8
- Fig. 6-16: Output current as a function of the resistance value 6-8
- Abb. 6-17: Power loss  $P_{EL}$  of the terminal R-IB IL 24 SEG/F 6-9
- Abb. 6-18: Power loss of the housing sector 1 6-9
- Abb. 6-19: Power loss of the housing sector 2 6-9
- Fig. 6-20: Typical power loss as a function of the load current 6-9
- Fig. 7-1: Ordering information of the terminals and the accessories 7-1
- Fig. 7-2: Order identification of Sub-D connectors 7-1

## 9 Index

### 2

24 V main incoming supply 4-11  
24 V peripheral supply 5-3  
24 V segment incoming supply 4-11

### A

Accessories 7-1  
Analog inputs 4-8  
Analog outputs 4-8  
Appropriate use  
    Area of application 2-2  
    Introduction 2-1  
    Uses 2-2

### C

Common potentials 5-7, 6-6

### D

Derating 6-7  
    R-IB IL 24 SEG/F 6-7  
Device master data file (GSD) 4-2  
Diagnosis display element R-IB IL 24 PWR IN 5-2  
Diagnosis display elements R-IB IL 24 SEG/F 6-2  
Diagnosis for each PROFIBUS 4-4  
Diagnostic indicators R-IL PB BK 4-3  
Digital inputs 4-8  
DIP switch of the PROFIBUS coupler 4-6  
DIP switches 4-7

### E

Explanation of the symbols 5-5, 6-5

### F

Feed in operating voltages 4-5  
Function modules 4-8

### I

Inappropriate use 2-2  
    Consequences, Discharge of liability 2-1  
INTERBUS  
    error messages 4-9  
    permissible Inline devices 4-8  
INTERBUS Inline devices 4-8  
Interface converters 7-1  
Internal circuit elements  
    R-IB IL SEG/F 6-5  
Internal protective elements 5-5  
Isolated potentials 5-7, 6-6

### L

Load current R-IB IL 24 SEG/F 6-7

**O**

Order Data 7-1  
Order identification 7-1  
    interface converters connectable in series 7-1  
Ordering information  
    accessories 7-1  
    terminals 7-1  
Output current R-IB IL 24 SEG/F 6-8  
Output voltage R-IB IL 24 SEG/F 6-8

**P**

Permissible total current 6-3  
PIN assignment of the 9-pin SUB-D connection socket 4-5  
PIN assignment R-IL PB BK 4-5  
Power loss 6-9  
    R-IB IL 24 SEG/F 6-9  
PROFIBUS connection 4-5  
PROFIBUS DP Interface 4-10  
Protective devices 6-3  
Protective devices R-IB IL 24 PWR IN 5-3

**R**

R-IB IL 24 PWR IN 1-1, 5-1  
R-IB IL 24 SEG/F 1-1, 6-1  
R-IL PB BK 4-1  
R-IL PB BK 1-1

**S**

Safety Instructions for Electric Servo Drives and Controls 3-3  
Segment circuit 6-1  
Sub-D connectors 7-1  
System data R-IL PB BK 4-10  
System termination resistors 4-7

**T**

Technical data R-IB IL 24 PWR IN 5-3  
Technical data R-IB IL 24 SEG/F 6-3  
Technical Data R-IL PB BK 4-10  
Terminal assignment  
    R-IB IL SEG/F 6-4  
Terminals 7-1  
Terminals R-IB IL 24 PWR IN 5-4  
Terminals R-IB IL SEG/F 6-4  
Test section R-IB IL 24 PWR IN / R-IB IL 24 SEG/F 5-7, 6-6

**U**

Use *See appropriate use and inappropriate use*

**V**

Voltage characteristics R-IB IL 24 SEG/F 6-7  
Voltage Supply 4-11

## 10 Service & Support

### 10.1 Helpdesk

Unser Kundendienst-Helpdesk im Hauptwerk Lohr am Main steht Ihnen mit Rat und Tat zur Seite. Sie erreichen uns

- telefonisch: **+49 (0) 9352 40 50 60**  
über Service Call Entry Center Mo-Fr 07:00-18:00
- per Fax: **+49 (0) 9352 40 49 41**
- per e-Mail: **service@indramat.de**

Our service helpdesk at our headquarters in Lohr am Main, Germany can assist you in all kinds of inquiries. Contact us

- by phone: **+49 (0) 9352 40 50 60**  
via Service Call Entry Center Mo-Fr 7:00 am - 6:00 pm
- by fax: **+49 (0) 9352 40 49 41**
- by e-mail: **service@indramat.de**

### 10.2 Service-Hotline

Außerhalb der Helpdesk-Zeiten ist der Service direkt ansprechbar unter

**+49 (0) 171 333 88 26**  
**+49 (0) 172 660 04 06**

oder

After helpdesk hours, contact our service department directly at

**+49 (0) 171 333 88 26**  
**+49 (0) 172 660 04 06**

or

### 10.3 Internet

Weitere Hinweise zu Service, Reparatur und Training finden Sie unter [www.indramat.de](http://www.indramat.de), sowie die **aktuellen** Adressen unserer Service- und Vertriebsbüros – die Angaben in dieser gedruckten Dokumentation können inzwischen überholt sein.

Außerhalb Deutschlands nehmen Sie bitte zuerst Kontakt mit Ihrem lokalen Ansprechpartner auf.

- Verkaufsniederlassungen  
 Niederlassungen mit Kundendienst

Additional notes about service, repairs and training are available on the Internet at [www.indramat.de](http://www.indramat.de) and also the **actual** addresses of our sales- and service facilities – the information in this printed documentation may meanwhile be obsolete.

Please contact the sales & service offices in your area first.

- sales agencies  
 offices providing service

### 10.4 Vor der Kontaktaufnahme... - Before contacting us...

Wir können Ihnen schnell und effizient helfen wenn Sie folgende Informationen bereithalten:

1. detaillierte Beschreibung der Störung und der Umstände.
2. Angaben auf dem Typenschild der betreffenden Produkte, insbesondere Typenschlüssel und Seriennummern.
3. Tel./Faxnummern und e-Mail-Adresse, unter denen Sie für Rückfragen zu erreichen sind.

For quick and efficient help, please have the following information ready:

1. Detailed description of the failure and circumstances.
2. Information on the type plate of the affected products, especially type codes and serial numbers.
3. Your phone/fax numbers and e-mail address, so we can contact you in case of questions.

## 10.5 Kundenbetreuungsstellen - Sales & Service Facilities

### Deutschland – Germany

vom Ausland: (0) nach Landeskennziffer weglassen!  
from abroad: don't dial (0) after country code!

Vertriebsgebiet Mitte Germany Centre  Rexroth Indramat GmbH Bgm.-Dr.-Nebel-Str. 2 97816 Lohr am Main  <b>Kompetenz-Zentrum Europa</b>  Tel.: +49 (0)9352 40-0 Fax: +49 (0)9352 40-4885	<b>SERVICE</b>  <b>CALL ENTRY CENTER</b> <b>MO – FR</b> <b>von 07:00 - 18:00 Uhr</b>  <b>from 7 am – 6 pm</b>  <b>Tel. +49 (0) 9352 40 50 60</b> <a href="mailto:service@indramat.de">service@indramat.de</a>	<b>SERVICE</b>  <b>HOTLINE</b> <b>MO – FR</b> <b>von 17:00 - 07:00 Uhr</b> <b>from 5 pm - 7 am</b> + SA / SO  <b>Tel.: +49 (0)172 660 04 06</b> <b>oder / or</b> <b>Tel.: +49 (0)171 333 88 26</b>	<b>SERVICE</b>  <b>ERSATZTEILE / SPARES</b> verlängerte Ansprechzeit - extended office time - ♦ nur an Werktagen - only on working days - ♦ von 07:00 - 18:00 Uhr - from 7 am - 6 pm -  <b>Tel. +49 (0) 9352 40 42 22</b>
Vertriebsgebiet Süd Germany South  Rexroth Indramat GmbH Landshuter Allee 8-10 80637 München Tel.: +49 (0)89 127 14-0 Fax: +49 (0)89 127 14-490 <a href="mailto:indramat.mue@t-online.de">indramat.mue@t-online.de</a>	Gebiet Südwest Germany South-West  Mannesmann Rexroth AG Vertrieb Deutschland – VD-BI Geschäftsbereich Rexroth Indramat Regionalzentrum Südwest Ringstrasse 70 / Postfach 1144 70736 Fellbach / 70701 Fellbach  Tel.: +49 (0)711 57 61–100 Fax: +49 (0)711 57 61–125	Vertriebsgebiet Ost Germany East  Rexroth Indramat GmbH Beckerstraße 31 09120 Chemnitz  Tel.: +49 (0)371 35 55-0 Fax: +49 (0)371 35 55-333	Vertriebsgebiet Nord Germany North  Mannesmann Rexroth AG Regionalzentrum Hannover Gesch.ber. Rexroth Indramat Walsroder Str. 93 30853 Langenhagen  Tel.: +49 (0) 511 72 66 57-0 Fax: +49 (0) 511 72 66 57-95
Vertriebsgebiet West Germany West  Mannesmann Rexroth AG Vertrieb Deutschland Regionalzentrum West Borsigstrasse 15 40880 Ratingen  Tel.: +49 (0)2102 409-0 Fax: +49 (0)2102 409-406	Vertriebsgebiet Mitte Germany Centre  Mannesmann Rexroth AG Gesch.ber. Rexroth Indramat Lilistrafße 14-18 63067 Offenbach  Tel.: +49 (0) 69 82 00 90-0 Fax: +49 (0) 69 82 00 90-80	Vertriebsgebiet Ost Germany East  Mannesmann Rexroth AG GB Rexroth Indramat GmbH Holzhäuser Str. 122 04299 Leipzig  Tel.: +49 (0)341 86 77-0 Fax: +49 (0)341 86 77-219	Vertriebsgebiet Nord Germany North  Rexroth Indramat GmbH Kieler Straße 212 22525 Hamburg  Tel.: +49 (0) 40 81 955 966 Fax: +49 (0) 40 85 418 978

## Europa (West) - Europe (West)

**vom Ausland:** (0) nach Landeskennziffer weglassen, **Italien:** 0 nach Landeskennziffer mitwählen  
**from abroad:** don't dial (0) after country code, **Italy:** dial 0 after country code

<p>Austria - Österreich</p> <p>Mannesmann Rexroth GmbH Bereich Indramat Stachegasse 13 1120 Wien</p> <p>Tel.: +43 (0)1 985 25 40 Fax: +43 (0)1 985 25 40-93</p>	<p>Austria - Österreich</p> <p>Mannesmann Rexroth G.m.b.H. Gesch.ber. Rexroth Indramat Industriepark 18 4061 Pasching</p> <p>Tel.: +43 (0)7221 605-0 Fax: +43 (0)7221 605-21</p>	<p>Belgium - Belgien</p> <p>Mannesmann Rexroth N.V.-S.A. Gesch.ber. Rexroth Indramat Industrielaan 8 1740 Ternat</p> <p>Tel.: +32 (0)2 5830719 Fax: +32 (0)2 5830731 <a href="mailto:indramat@rexroth.be">indramat@rexroth.be</a></p>	<p>Denmark - Dänemark</p> <p>BEC AS Zinkvej 6 8900 Randers</p> <p>Tel.: +45 (0)87 11 90 60 Fax: +45 (0)87 11 90 61</p>
<p>England</p> <p>Mannesmann Rexroth Ltd. Rexroth Indramat Division Broadway Lane, South Cerney Cirencester, Glos GL7 5UH</p> <p>Tel.: +44 (0)1285 863000 Fax: +44 (0)1285 863030 <a href="mailto:sales@indramat.co.uk">sales@indramat.co.uk</a> <a href="mailto:service@indramat.co.uk">service@indramat.co.uk</a></p>	<p>Finland - Finnland</p> <p>Rexroth Mecman Oy Rexroth Indramat division Ansatie 6 017 40 Vantaa</p> <p>Tel.: +358 (0)9 84 91-11 Fax: +358 (0)9 84 91-13 60</p>	<p>France - Frankreich</p> <p>Mannesmann Rexroth S.A. Division Rexroth Indramat Avenue de la Trentaine BP. 74 77503 CHELLES CEDEX</p> <p>Tel.: +33 (0)164 72-70 00 Fax: +33 (0)164 72-63 00 <b>Hotline:</b> +33 (0)608 33 43 28</p>	<p>France - Frankreich</p> <p>Mannesmann Rexroth S.A. Division Rexroth Indramat 1270, Avenue de Lardenne 31100 Toulouse</p> <p>Tel.: +33 (0)5 61 49 95 19 Fax: +33 (0)5 61 31 00 41</p>
<p>France - Frankreich</p> <p>Mannesmann Rexroth S.A. Division Rexroth Indramat 91, Bd. Irène Joliot-Curie 69634 Vénissieux – Cedex</p> <p>Tel.: +33 (0)4 78 78 53 65 Fax: +33 (0)4 78 78 53 62</p>	<p>Italy - Italien</p> <p>Mannesmann Rexroth S.p.A. Divisione Rexroth Indramat Via G. Di Vittoria, 1 20063 Cernusco S/N.MI</p> <p>Tel.: +39 02 2 365 270 Fax: +39 02 700 408 252378</p>	<p>Italy - Italien</p> <p>Mannesmann Rexroth S.p.A. Divisione Rexroth Indramat Via Borgomanero, 11 10145 Torino</p> <p>Tel.: +39 011 7 50 38 11 Fax: +39 011 7 71 01 90</p>	<p>Italy - Italien</p> <p>Mannesmann Rexroth S.p.A. Divisione Rexroth Indramat Via del Progresso, 16 (Zona Ind.) 35020 Padova</p> <p>Tel.: +39 049 8 70 13 70 Fax: +39 049 8 70 13 77</p>
<p>Italy - Italien</p> <p>Mannesmann Rexroth S.p.A. Divisione Rexroth Indramat Via Mascia, 1 80053 Castellammare di Stabia NA</p> <p>Tel.: +39 081 8 71 57 00 Fax: +39 081 8 71 68 85</p>	<p>Italy - Italien</p> <p>Mannesmann Rexroth S.p.A. Divisione Rexroth Indramat Viale Oriani, 38/A 40137 Bologna</p> <p>Tel.: +39 051 34 14 14 Fax: +39 051 34 14 22</p>	<p>Netherlands - Niederlande/Holland</p> <p>Rexroth B.V. Kruisbroeksestraat 1 (P.O. Box 32) 5281 RV Boxtel</p> <p>Tel.: +31 (0)411 65 19 51 Fax: +31 (0)411 65 14 83 <a href="mailto:indramat@hydraudyne.nl">indramat@hydraudyne.nl</a></p>	<p>Netherlands - Niederlande/Holland</p> <p>Rexroth Hydrocare B.V. Kruisbroeksestraat 1 (P.O. Box 32) 5281 RV Boxtel</p> <p>Tel.: +31 (0)411 65 19 51 Fax: +31 (0)411 67 78 14</p>
<p>Norway - Norwegen</p> <p>Rexroth Mecman AS Rexroth Indramat Division Berghagan 1 or: Box 3007 1405 Ski-Langhus 1402 Ski</p> <p>Tel.: +47 (0)64 86 41 00 Fax: +47 (0)64 86 90 62 <a href="mailto:jul.ruud@rexroth.no">jul.ruud@rexroth.no</a></p>	<p>Spain - Spanien</p> <p>Mannesmann Rexroth S.A. División Rexroth Indramat Centro Industrial Santiga Obradors s/n 08130 Santa Perpetua de Mogoda Barcelona</p> <p>Tel.: +34 9 37 47 94 00 Fax: +34 9 37 47 94 01</p>	<p>Spain - Spanien</p> <p>Goimendi S.A. División Rexroth Indramat Parque Empresarial Zuatzu C/ Francisco Grandmontagne no.2 20018 San Sebastian</p> <p>Tel.: +34 9 43 31 84 21 - service: +34 9 43 31 84 56 Fax: +34 9 43 31 84 27 - service: +34 9 43 31 84 60 <a href="mailto:satindramat-goimendi@adegi.es">satindramat-goimendi@adegi.es</a></p>	<p>Sweden - Schweden</p> <p>Rexroth Mecman Svenska AB Rexroth Indramat Division Varuvägen 7 125 81 Stockholm</p> <p>Tel.: +46 (0)8 727 92 00 Fax: +46 (0)8 647 32 77</p>
<p>Sweden - Schweden</p> <p>Rexroth Mecman Svenska AB Indramat Support Ekvändan 7 254 67 Helsingborg</p> <p>Tel.: +46 (0) 42 38 88 -50 Fax: +46 (0) 42 38 88 -74</p>	<p>Switzerland West - Schweiz West</p> <p>Bosch Rexroth Suisse SA Département Rexroth Indramat Rue du village 1 1020 Renens</p> <p>Tel.: +41 (0)21 632 84 20 Fax: +41 (0)21 632 84 21</p>	<p>Switzerland East - Schweiz Ost</p> <p>Bosch Rexroth Schweiz AG Geschäftsbereich Indramat Hemrietstrasse 2 8863 Buttikon</p> <p>Tel. +41 (0) 55 46 46 205 Fax +41 (0) 55 46 46 222</p>	

## Europa (Ost) - Europe (East)

**vom Ausland:** (0) nach Landeskenziffer weglassen  
**from abroad:** don't dial (0) after country code

Czech Republic - Tschechien	Czech Republic - Tschechien	Hungary - Ungarn	Poland – Polen
Mannesmann-Rexroth, spol.s.r.o. Hviezdoslavova 5 627 00 Brno  Tel.: +420 (0)5 48 126 358 Fax: +420 (0)5 48 126 112	DEL a.s. Strojirenská 38 Zdar nad Sázavou 591 01 Czech republic Tel.: +420 616 64 3144 Fax: +420 616 216 57	Mannesmann Rexroth Kft. Angol utca 34 1149 Budapest  Tel.: +36 (1) 364 00 02 Fax: +36 (1) 383 19 80	Mannesmann Rexroth Sp.zo.o. Biuro Poznan ul. Dabrowskiego 81/85 60-529 Poznan Tel.: +48 061 847 67 99 Fax: +48 061 847 64 02
Rumania - Rumänien	Russia - Russland	Russia - Russland	Turkey - Türkei
Mannesmann Rexroth Sp.zo.o. Str. Drobety nr. 4-10, app. 14 70258 Bucuresti, Sector 2  Tel.: +40 (0)1 210 48 25 +40 (0)1 210 29 50 Fax: +40 (0)1 210 29 52	Mannesmann Rexroth INDRAMAT Wolokolamskoje Chaussee 73 Zimmer 406, 408 RUS – 123424 Moskau Tel.: +7 095/ 232 08 34 +7 095/ 232 08 35 Fax: +7 095/ 232 08 36 <a href="mailto:info.rex@rexroth.ru">info.rex@rexroth.ru</a>	ELMIS 10, Internationalnaya Str. 246640 Gomel, Belarus Tel.: +375/ 232 53 42 70 Fax: +375/ 232 53 37 69 <a href="mailto:elmis_ltd@yahoo.com">elmis_ltd@yahoo.com</a>	Mannesmann Rexroth Hidropar A..S. Fevzi Cakmak Cad No. 3 34630 Sefaköy Istanbul Tel.: +90 212 541 60 70 Fax: +90 212 599 34 07
Slowenia - Slowenien			
DOMEL Otoki 21 64 228 Zelezniki Tel.: +386 5 5117 152 Fax: +386 5 5117 225 <a href="mailto:brane.ozebek@domel.si">brane.ozebek@domel.si</a>			

## Africa, Asia, Australia – incl. Pacific Rim

**vom Ausland:** (0) nach Landeskenziffer weglassen!  
**from abroad:** don't dial (0) after country code!

<p>Australia - Australien</p> <p>AIMS - Australian Industrial Machinery Services Pty. Ltd. Unit 3/45 Horne ST Campbellfield , VIC 3061 Melbourne Tel.: +61 (0) 393 590 228 Fax: +61 (0) 393 590 286 Hotline: +61 (0) 419 369 195 <a href="mailto:terryobrien@aimservices.com.au">terryobrien@aimservices.com.au</a></p>	<p>Australia - Australien</p> <p>Bosch Rexroth Pty. Ltd. No. 7, Endeavour Way Braeside Victoria, 31 95 Melbourne Tel.: +61 (0)3 95 80 39 33 Fax: +61 (0)3 95 80 17 33 <a href="mailto:mel@rexroth.com.au">mel@rexroth.com.au</a></p>	<p>China</p> <p>Shanghai Mannesmann Rexroth Hydraulics &amp; Automation Ltd. Wai Gaoqiao Free Trade Zone No.122, Fu Te Dong Yi Road Shanghai 200131 - P.R.China Tel.: +86 21 58 66 30 30 Fax: +86 21 58 66 55 23 <a href="mailto:leonww@citiz.net">leonww@citiz.net</a></p>	<p>China</p> <p>Mannesmann Rexroth (China) Ltd. 15/F China World Trade Center 1, Jianguomenwai Avenue Beijing 100004, P.R.China Tel.: +86 10 65 05 03 80 Fax: +86 10 65 05 03 79</p>
<p>China</p> <p>Mannesmann Rexroth (China) Ltd. A-5F., 123 Lian Shan Street Sha He Kou District Dalian 116 023, P.R.China Tel.: +86 411 46 78 930 Fax: +86 411 46 78 932</p>	<p>China</p> <p>Mannesmann Rexroth (China) Ltd. Guangzhou Repres. Office Room 1014-1016, Metro Plaza, Tian He District, 183 Tian He Bei Rd Guangzhou 510075, P.R.China Tel.: +86 20 8755-0030 +86 20 8755-0011 Fax: +86 20 8755-2387</p>	<p>Hongkong</p> <p>Rexroth (China) Ltd. 1/F., 19 Cheung Shun Street Cheung Sha Wan, Kowloon, Hongkong Tel.: +852 22 62 51 00 Fax: +852 27 41 33 44</p>	<p>India - Indien</p> <p>Mannesmann Rexroth (India) Ltd. Rexroth Indramat Division Plot. A-58, TTC Industrial Area Thane Turbhe Midc Road Mahape Village Navi Mumbai - 400 701 Tel.: +91 (0)22 7 61 46 22 Fax: +91 (0)22 7 68 15 31</p>
<p>India - Indien</p> <p>Mannesmann Rexroth (India) Ltd. Rexroth Indramat Division Plot. 96, Phase III Peenya Industrial Area Bangalore - 560058 Tel.: +91 (0)80 8 39 73 74 Fax: +91 (0)80 8 39 43 45</p>	<p>Indonesia - Indonesien</p> <p>PT. Rexroth Wijayakusuma Building # 202, Cilandak Commercial Estate Jl. Cilandak KKO, Jakarta 12560 Tel.: +62 21 7891169 (5 lines) Fax: +62 21 7891170 - 71</p>	<p>Japan</p> <p>Rexroth Automation Co., Ltd. Service Center Japan Yutakagaoka 1810, Meito-ku, NAGOYA 465-0035, Japan Tel.: +81 (0)52 777 88 41 +81 (0)52 777 88 53 +81 (0)52 777 88 79 Fax: +81 (0)52 777 89 01</p>	<p>Japan</p> <p>Rexroth Automation Co., Ltd. Rexroth Indramat Division 1F, I.R. Building Nakamachidai 4-26-44, Tsuzuki-ku YOKOHAMA 224-0041, Japan Tel.: +81 (0)45 942 72 10 Fax: +81 (0)45 942 03 41</p>
<p>Korea</p> <p>Mannesmann Rexroth-Korea Ltd. 1515-14 Dadae-Dong, Saha-Ku Rexroth Indramat Division Pusan Metropolitan City, 604-050 Republic of South Korea Tel.: +82 (0)51 26 00 741 Fax: +82 (0)51 26 00 747 <a href="mailto:gyhan@rexrothkorea.co.kr">gyhan@rexrothkorea.co.kr</a></p>	<p>Malaysia</p> <p>Mannesmann Rexroth SDN.BHD. Head Office No. 3, Block B, Jalan SS 13/5 Subang Jaya Industrial Estate 47500 Petaling Jaya - Selangor Tel.: +60 (0) 3 73 44 870 Fax: +60 (0) 3 73 44 864 <a href="mailto:hockhwa@hotmail.com">hockhwa@hotmail.com</a></p>	<p>South Africa - Südafrika</p> <p>TECTRA Automation (Pty) Ltd. 28 Banfield Road, Industria North RSA - Maraisburg 1700 Tel.: +27 (0)11 673 20 80 Fax: +27 (0)11 673 72 69 Hotline: +27 (0)82 903 29 23 <a href="mailto:georgv@tectra.co.za">georgv@tectra.co.za</a></p>	<p>Taiwan</p> <p>Rexroth Uchida Co., Ltd. No.17, Lane 136, Cheng Bei 1 Rd., Yung Kang, Tainan Hsien Taiwan, R.O.C. Tel.: +886 (0)6 25 36 565 Fax: +886 (0)6 25 34 754 <a href="mailto:indramat@mail.net.tw">indramat@mail.net.tw</a></p>
<p>Thailand</p> <p>NC Advance Technology Co. Ltd. 59/76 Moo 9 Ramintra road 34 Tharang, Bangkokhen, Bangkok 10230 Tel.: +66 2 943 70 62 +66 2 943 71 21 Fax: +66 2 509 23 62 <a href="mailto:sonkawin@hotmail.com">sonkawin@hotmail.com</a></p>			

## Nordamerika – North America

<b>USA</b> Hauptniederlassung - Headquarters Mannesmann Rexroth Corporation Rexroth Indramat Division 5150 Prairie Stone Parkway Hoffman Estates, IL 60192-3707 Tel.: +1 847 6 45 36 00 Fax: +1 847 6 45 62 01 <a href="mailto:service@indramat.com">service@indramat.com</a>	<b>USA Central Region - Mitte</b> Mannesmann Rexroth Corporation Rexroth Indramat Division Central Region Technical Center Auburn Hills, MI 48326 Tel.: +1 248 3 93 33 30 Fax: +1 248 3 93 29 06	<b>USA Southeast Region - Südwest</b> Mannesmann Rexroth Corporation Rexroth Indramat Division Southeastern Technical Center 3625 Swiftwater Park Drive Suwanee, Georgia 30174 Tel.: +1 770 9 32 32 00 Fax: +1 770 9 32 19 03	<b>USA SERVICE-HOTLINE</b>  - 7 days x 24hrs -  <b>+1-800-860-1055</b>
<b>USA East Region –Ost</b> Mannesmann Rexroth Corporation Rexroth Indramat Division Charlotte Regional Sales Office 14001 South Lakes Drive Charlotte, North Carolina 28273 Tel.: +1 704 5 83 97 62 +1 704 5 83 14 86	<b>USA Northeast Region – Nordost</b> Mannesmann Rexroth Corporation Rexroth Indramat Division Northeastern Technical Center 99 Rainbow Road East Granby, Connecticut 06026 Tel.: +1 860 8 44 83 77 Fax: +1 860 8 44 85 95	<b>USA West Region – West</b> Rexroth Indramat – Western Office 7901 Stoneridge Drive, Suite 220 Pleasant Hill, California 94588 Tel.: +1 925 227 10 84 Fax: +1 925 227 10 81	
<b>Canada East - Kanada Ost</b> Basic Technologies Corporation Burlington Division 3426 Mainway Drive Burlington, Ontario Canada L7M 1A8 Tel.: +1 905 335 55 11 Fax: +1 905 335-41 84 <a href="mailto:michael.moro@basic.ca">michael.moro@basic.ca</a>	<b>Canada West - Kanada West</b> Basic Automation Burnaby 5345 Goring St. Burnaby, British Columbia Canada V7J 1R1 Tel.: +1 604 205-5777 Fax: +1 604 205-6944 <a href="mailto:david.gunby@basic.ca">david.gunby@basic.ca</a>		

## Südamerika – South America

<b>Argentina - Argentinien</b> Mannesmann Rexroth S.A.I.C. Division Rexroth Indramat Acassuso 48 41/7 RA - 1605 Munro (Buenos Aires) Tel.: +54 (0)11 4756 01 40 Fax: +54 (0)11 4762 6862	<b>Argentina - Argentinien</b> NAKASE Servicio Tecnico CNC Calle 49, No. 5764/66 RA - 1653 Villa Balester Prov. - Buenos Aires Tel.: +54 (0) 11 4768 36 43 Fax: +54 (0) 11 4768 24 13 <a href="mailto:nakase@usa.net">nakase@usa.net</a> <a href="mailto:nakase@nakase.com">nakase@nakase.com</a>	<b>Brazil - Brasilien</b> Mannesmann Rexroth Automação Ltda. Divisão Rexroth Indramat Av. Tégula, 888 Ponte Alta, Atibaia SP CEP 12940-000 Tel.: +55 (0)11 4414 56 92 +55 (0)11 4414 56 84 Fax sales: +55 (0)11 4414 57 07 Fax serv.: +55 (0)11 4414 56 86 <a href="mailto:alexandre.wittwer@rexroth.com.br">alexandre.wittwer@rexroth.com.br</a>	<b>Brazil - Brasilien</b> Mannesmann Rexroth Automação Ltda. Divisão Rexroth Indramat R. Dr.Humberto Pinheiro Vieira, 100 Distrito Industrial [Caixa Postal 1273] BR - 89220-390 Joinville - SC Tel./Fax: +55 (0)47 473 58 33 Mobil: +55 (0)47 9974 6645 <a href="mailto:prochnow@zaz.com.br">prochnow@zaz.com.br</a>
<b>Mexico</b> Mannesmann Rexroth Mexico S.A. de C.V. Calle Neptuno 72 Unidad Ind. Vallejo MEX - 07700 Mexico, D.F. Tel.: +52 5 754 17 11 +52 5 754 36 84 +52 5 754 12 60 Fax: +52 5 754 50 73 +52 5 752 59 43	<b>Columbia - Kolumbien</b> Reflutec de Colombia Ltda. Calle 37 No. 22-31 Santafé de Bogotá, D.C. Colombia Tel.: +57 1 368 82 67 +57 1 368 02 59 Fax: +57 1 268 97 37 <a href="mailto:reflutec@inter.net.co">reflutec@inter.net.co</a>		





Printed in Germany