

# Rexroth VAM 10.1 Rexroth VAM 40.1

R911306781  
Edition 02

## Project Planning Manual

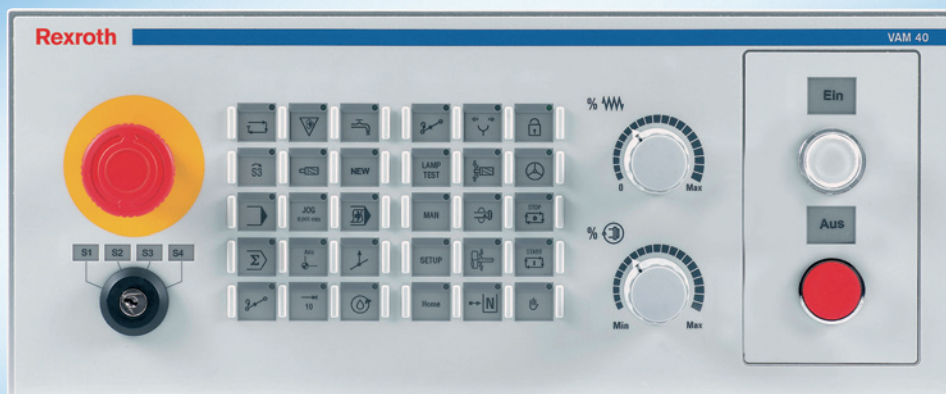

<b>Title</b>	Rexroth VAM 10.1 Rexroth VAM 40.1
<b>Type of Documentation</b>	Project Planning Manual
<b>Document Typecode</b>	DOK-SUPPL*-VAM*10/40**-PR02-EN-P
<b>Internal File Reference</b>	Document Number, 120-2100-B365-02/EN
<b>Purpose of Documentation</b>	This documentation describes the machine operator panels VAM 10.1 and VAM 40.1.

**Record of Revisions**

Description	Release Date	Notes
120-2100-B365-02/EN	02/05	First English Edition

**Copyright** © 2005 Bosch Rexroth AG

Copying this document, giving it to others and the use or communication of the contents thereof without express authority, are forbidden. Offenders are liable for the payment of damages. All rights are reserved in the event of the grant of a patent or the registration of a utility model or design (DIN 34-1).

**Validity** The specified data is for product description purposes only and may not be deemed to be guaranteed unless expressly confirmed in the contract. All rights are reserved with respect to the content of this documentation and the availability of the product.

**Published by** Bosch Rexroth AG  
Bgm.-Dr.-Nebel-Str. 2 • D-97816 Lohr a. Main  
Telephone +49 (0)93 52/40-0 • Tx 68 94 21 • Fax +49 (0)93 52/40-48 85  
<http://www.boschrexroth.com/>  
Dept. BRC/EPY (NH)

**Note** This document has been printed on chlorine-free bleached paper.

# Contents

<b>1</b>	<b>System Presentation</b>	<b>1-1</b>
1.1	Brief Description .....	1-1
1.2	Machine Operator Panel VAM 10.1 .....	1-1
1.3	Machine Operator Panel VAM 40.1 .....	1-2
1.4	Use of the Machine Operator Panels in Residential Areas .....	1-2
<b>2</b>	<b>Important Directions for Use</b>	<b>2-1</b>
2.1	Appropriate Use .....	2-1
	Introduction .....	2-1
	Areas of Use and Application .....	2-2
2.2	Inappropriate Use .....	2-2
<b>3</b>	<b>Safety Instructions for Electric Drives and Controls</b>	<b>3-1</b>
3.1	Introduction .....	3-1
3.2	Explanations .....	3-1
3.3	Hazards by Improper Use .....	3-2
3.4	General Information .....	3-3
3.5	Protection Against Contact with Electrical Parts .....	3-4
3.6	Protection Against Electric Shock by Protective Low Voltage (PELV) .....	3-5
3.7	Protection Against Dangerous Movements .....	3-6
3.8	Protection Against Magnetic and Electromagnetic Fields During Operation and Mounting .....	3-7
3.9	Protection Against Contact with Hot Parts .....	3-8
3.10	Protection During Handling and Mounting .....	3-8
3.11	Battery Safety .....	3-9
3.12	Protection Against Pressurized Systems .....	3-9
<b>4</b>	<b>Technical Data</b>	<b>4-1</b>
4.1	Basic Device .....	4-1
4.2	Key Switch .....	4-2
4.3	Machine Pushbutton and E-STOP .....	4-3
4.4	Ambient Conditions .....	4-3
4.5	Used Standards .....	4-4
4.6	Compatibility Test .....	4-4

<b>5</b>	<b>Dimensions</b>	<b>5-1</b>
5.1	Housing Dimensions.....	5-1
	Housing Dimensions VAM 10.1, Front, Side and Top View.....	5-1
	Housing Dimensions VAM 10.1, Rear View.....	5-1
	Housing Dimensions VAM 40.1, Front, Side and Top View.....	5-2
	Housing Dimensions VAM 40.1, Rear View.....	5-2
5.2	Installation.....	5-3
	Installation Notes.....	5-3
	Mounting Cut-Out.....	5-3
	Mounting Dimensions VAM 10.1.....	5-4
	Mounting Dimensions VAM 40.1.....	5-4
<b>6</b>	<b>Module Layout</b>	<b>1</b>
6.1	General Information.....	1
	Labeling Templates for Slide-In Strips.....	1
6.2	Basic Device.....	1
	E-STOP and Key Switch.....	2
	Keypads.....	2
	Override Rotary Switch.....	3
6.3	Modules.....	4
	Quick STOP Module.....	4
	Further Modules.....	4
<b>7</b>	<b>Interfaces</b>	<b>7-1</b>
7.1	Connector Panel.....	7-1
7.2	Protective Earth Terminal.....	7-1
7.3	Current and Voltage Supply (X10).....	7-2
7.4	Field Bus Interface PROFIBUS DP (X71).....	7-3
	General Information.....	7-3
	Pin Assignment.....	7-3
7.5	Digital 24 V Inputs and Outputs (X21, X22, X11).....	7-4
	Pin Assignment (3 x 8-Pin Weidmüller Connector (3.5 Grid)).....	7-4
	Characteristics of Digital Inputs.....	7-5
	Characteristics of Digital Outputs.....	7-5
7.6	Connection for External Hand-Held Terminal (X81).....	7-5
7.7	Connection for Internal Handwheel (X82).....	7-7
<b>8</b>	<b>Commissioning</b>	<b>8-1</b>
8.1	GSD File.....	8-1
8.2	PROFIBUS DP Address Settings.....	8-2
8.3	Baud Rate Setting.....	8-3
8.4	Status Displays.....	8-3

8.5	Address Assignment.....	8-6
	Keypads.....	8-6
	Override Rotary Switch.....	8-7
	Digital 24 V Inputs and Outputs.....	8-8
	External Hand-Held Terminal .....	8-8
	Internal Handwheel.....	8-8
8.6	Configuration Specification.....	8-9
	VAM 10.1-PB-NA-TA-TA-VB-1608-NN .....	8-9
	VAM 40.1-PB-NA-TA-TA-VB-1608-NN .....	8-9
8.7	Exemplary Configuration with IndraLogic.....	8-10
<b>9</b>	<b>Ordering Information</b>	<b>9-1</b>
9.1	Type Code .....	9-1
9.2	Accessories .....	9-3
<b>10</b>	<b>List of Figures</b>	<b>10-1</b>
<b>11</b>	<b>Service &amp; Support</b>	<b>11-1</b>
11.1	Helpdesk.....	11-1
11.2	Service-Hotline .....	11-1
11.3	Internet.....	11-1
11.4	Vor der Kontaktaufnahme... - Before contacting us... ..	11-1
11.5	Kundenbetreuungsstellen - Sales & Service Facilities .....	11-2



# 1 System Presentation

## 1.1 Brief Description

Machine operator panels complete machine operator terminals and are used to select the operating modes as well as to operate the machine manually. Thus, they contain the necessary operating elements, e. g., keys with LED displays, rotary switches for feed and spindle override, E-STOP pushbuttons, key switches and machine pushbuttons.

The machine operator panels VAM 10.1 and VAM 40.1 have been specially designed for the use in combination with the operator terminals BTV 16 and BTV 40 and are adapted to the design of the operator terminals. Thereby, the width of the VAM 10.1 corresponds to the width of the BTV 16 and the width of the VAM 40.1 is equal to the width of the BTV 40.

VAM-type devices are machine operator panels for CNC machines with PROFIBUS connection.

## 1.2 Machine Operator Panel VAM 10.1

The VAM 10.1 is the compact variant of the VAM-Type devices. The machine operator panel VAM 10.1 is equipped with an E-STOP pushbutton, a 4-stage key switch, two keypads each including 15 keys, that might be labeled and programmed according to the system requirements, and with two override rotary switches for feed and spindle.

Additionally, on the rear side the following components are available:

- 25-pin connector to connect a hand-held terminal
- 6-pin connector to connect a handwheel
- 16 digital 24 V inputs
- 8 digital 24 V outputs

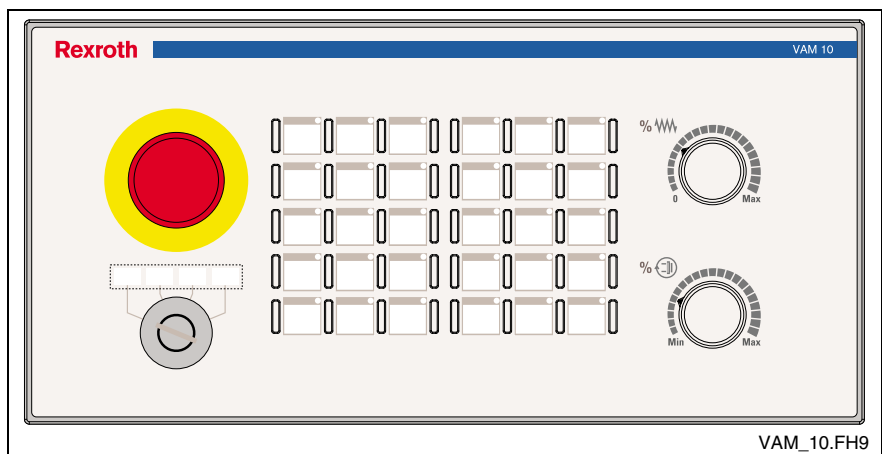

Fig. 1-1: Front view VAM 10.1

### 1.3 Machine Operator Panel VAM 40.1

In addition to the components of the VAM 10.1 the VAM 40.1 provides as partly modular variant a flexible fifth module slot. Initially, as default variant for the fifth module slot a preconfigured module with two machine pushbuttons (white lit and red unlit) is provided. Optionally, the fifth module slot can also be equipped with e. g., a blind plate or a handwheel module (at present, not yet available).

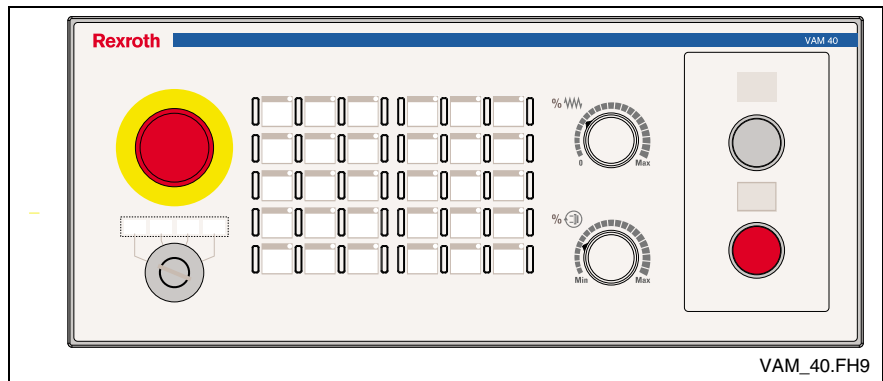

Fig. 1-2: Front view VAM 40.1

### 1.4 Use of the Machine Operator Panels in Residential Areas

Systems with VAM 10.1-type and VAM 40.1-type machine operator panels used in residential areas (housing, business and commercial areas as well as small-sized enterprises) require a single approval by an authority or a testing agency. In Germany, such single approvals are issued by the "Regulierungsbehörde für Telekommunikation und Post (RegTP)" (German Regulatory Authority for Telecommunications and Posts).

## 2 Important Directions for Use

### 2.1 Appropriate Use

#### Introduction

Bosch Rexroth products represent state-of-the-art developments and manufacturing. They are tested prior to delivery to ensure operating safety and reliability.

The products may only be used in the manner that is defined as appropriate. If they are used in an inappropriate manner, then situations can develop that may lead to property damage or injury to personnel.

---

**Note:** Bosch Rexroth, as manufacturer, is not liable for any damages resulting from inappropriate use. In such cases, the guarantee and the right to payment of damages resulting from inappropriate use are forfeited. The user alone carries all responsibility of the risks.

---

Before using Bosch Rexroth products, make sure that all the prerequisites for appropriate use of the products are satisfied:

- Personnel that in any way, shape or form uses our products must first read and understand the relevant safety instructions and be familiar with appropriate use.
- If the product takes the form of hardware, then they must remain in their original state, in other words, no structural changes are permitted. It is not permitted to decompile software products or alter source codes.
- Do not mount damaged or faulty products or use them in operation.
- Make sure that the products have been installed in the manner described in the relevant documentation.

## Areas of Use and Application

VAM-type operating devices of Bosch Rexroth are machine operator panels configurable with modules, that can be ordered according to the requirements of the respective project. Their purpose is to operate control units at a machine.

---

**Note:** The machine operator panels VAM 10.1 and VAM 40.1 may only be used with the accessories and parts specified in this document. If a component has not been specifically named, then it may not be either mounted or connected. The same applies to cables and lines.

Operation is only permitted in the specified configurations and combinations of components using the software and firmware as specified in the relevant function descriptions.

---

The machine operator panels VAM 10.1 and VAM 40.1 are designed for control tasks.

Typical applications of the VAM 10.1 / VAM 40.1 are:

- Lathes,
- Milling machines,
- Machining centers.

The machine operator panels VAM 10.1 and VAM 40.1 may only be operated under the assembly, installation and ambient conditions as described here (temperature, system of protection, humidity, EMC requirements, etc.) and in the position specified.

## 2.2 Inappropriate Use

Using machine operator panels VAM 10.1 and VAM 40.1 outside of the above-referenced areas of application or under operating conditions other than described in the document and the technical data specified is defined as "inappropriate use".

The machine operator panels VAM 10.1 and VAM 40.1 may not be used, if

- they are subject to operating conditions that do not meet the above specified ambient conditions. This includes, for example, operation under water, in the case of extreme temperature fluctuations or extremely high maximum temperatures or if
- Bosch Rexroth has not specifically released them for that intended purpose. Please note the specifications outlined in the general Safety Guidelines!

## 3 Safety Instructions for Electric Drives and Controls

### 3.1 Introduction

Read these instructions before the initial startup of the equipment in order to eliminate the risk of bodily harm or material damage. Follow these safety instructions at all times.

Do not attempt to install or start up this equipment without first reading all documentation provided with the product. Read and understand these safety instructions and all user documentation of the equipment prior to working with the equipment at any time. If you do not have the user documentation for your equipment, contact your local Bosch Rexroth representative to send this documentation immediately to the person or persons responsible for the safe operation of this equipment.

If the equipment is resold, rented or transferred or passed on to others, then these safety instructions must be delivered with the equipment.



**WARNING**

**Improper use of this equipment, failure to follow the safety instructions in this document or tampering with the product, including disabling of safety devices, may result in material damage, bodily harm, electric shock or even death!**

### 3.2 Explanations

The safety instructions describe the following degrees of hazard seriousness in compliance with ANSI Z535. The degree of hazard seriousness informs about the consequences resulting from non-compliance with the safety instructions.

Warning symbol with signal word	Degree of hazard seriousness according to ANSI
 <b>DANGER</b>	Death or severe bodily harm will occur.
 <b>WARNING</b>	Death or severe bodily harm may occur.
 <b>CAUTION</b>	Bodily harm or material damage may occur.

Fig. 3-1: Hazard classification (according to ANSI Z535)

### 3.3 Hazards by Improper Use



**DANGER**

**High voltage and high discharge current!  
Danger to life or severe bodily harm by electric shock!**

---



**DANGER**

**Dangerous movements! Danger to life, severe bodily harm or material damage by unintentional motor movements!**

---



**WARNING**

**High electrical voltage due to wrong connections! Danger to life or bodily harm by electric shock!**

---



**WARNING**

**Health hazard for persons with heart pacemakers, metal implants and hearing aids in proximity to electrical equipment!**

---



**CAUTION**

**Surface of machine housing could be extremely hot! Danger of injury! Danger of burns!**

---



**CAUTION**

**Risk of injury due to improper handling! Bodily harm caused by crushing, shearing, cutting and mechanical shock or incorrect handling of pressurized systems!**

---



**CAUTION**

**Risk of injury due to incorrect handling of batteries!**

---

## 3.4 General Information

- Bosch Rexroth AG is not liable for damages resulting from failure to observe the warnings provided in this documentation.
- Read the operating, maintenance and safety instructions in your language before starting up the machine. If you find that you cannot completely understand the documentation for your product, please ask your supplier to clarify.
- Proper and correct transport, storage, assembly and installation as well as care in operation and maintenance are prerequisites for optimal and safe operation of this equipment.
- Only persons who are trained and qualified for the use and operation of the equipment may work on this equipment or within its proximity.
  - The persons are qualified if they have sufficient knowledge of the assembly, installation and operation of the equipment as well as an understanding of all warnings and precautionary measures noted in these instructions.
  - Furthermore, they must be trained, instructed and qualified to switch electrical circuits and equipment on and off in accordance with technical safety regulations, to ground them and to mark them according to the requirements of safe work practices. They must have adequate safety equipment and be trained in first aid.
- Only use spare parts and accessories approved by the manufacturer.
- Follow all safety regulations and requirements for the specific application as practiced in the country of use.
- The equipment is designed for installation in industrial machinery.
- The ambient conditions given in the product documentation must be observed.
- Use only safety features and applications that are clearly and explicitly approved in the Project Planning Manual. If this is not the case, they are excluded.

The following areas of use and application, for example, include safety features and applications: construction cranes, elevators used for people or freight, devices and vehicles to transport people, medical applications, refinery plants, transport of hazardous goods, nuclear applications, applications in which electrical devices with vital functions can be electromagnetically disturbed, mining, food processing, control of protection equipment (also in a machine).
- The information given in the documentation of the product with regard to the use of the delivered components contains only examples of applications and suggestions.

The machine and installation manufacturer must

  - make sure that the delivered components are suited for his individual application and check the information given in this documentation with regard to the use of the components,
  - make sure that his application complies with the applicable safety regulations and standards and carry out the required measures, modifications and complements.
- Startup of the delivered components is only permitted once it is sure that the machine or installation in which they are installed complies with the national regulations, safety specifications and standards of the application.
- Technical data, connections and operational conditions are specified in the product documentation and must be followed at all times.

- Operation is only permitted if the national EMC regulations for the application are met.  
The instructions for installation in accordance with EMC requirements can be found in the documentation "EMC in Drive and Control Systems".  
The machine or installation manufacturer is responsible for compliance with the limiting values as prescribed in the national regulations.

## 3.5 Protection Against Contact with Electrical Parts

---

**Note:** This section refers to equipment and drive components with voltages above 50 Volts.

---

Touching live parts with voltages of 50 Volts and more with bare hands or conductive tools or touching ungrounded housings can be dangerous and cause electric shock. In order to operate electrical equipment, certain parts must unavoidably have dangerous voltages applied to them.

---



**DANGER**

### High electrical voltage! Danger to life, severe bodily harm by electric shock!

- ⇒ Only those trained and qualified to work with or on electrical equipment are permitted to operate, maintain or repair this equipment.
  - ⇒ Follow general construction and safety regulations when working on high voltage installations.
  - ⇒ Before switching on power the ground wire must be permanently connected to all electrical units according to the connection diagram.
  - ⇒ Do not operate electrical equipment at any time, even for brief measurements or tests, if the ground wire is not permanently connected to the points of the components provided for this purpose.
  - ⇒ Before working with electrical parts with voltage higher than 50 V, the equipment must be disconnected from the mains voltage or power supply. Make sure the equipment cannot be switched on again unintended.
  - ⇒ The following should be observed with electrical drive and filter components:
    - ⇒ Wait thirty (30) minutes after switching off power to allow capacitors to discharge before beginning to work. Measure the voltage on the capacitors before beginning to work to make sure that the equipment is safe to touch.
    - ⇒ Never touch the electrical connection points of a component while power is turned on.
    - ⇒ Install the covers and guards provided with the equipment properly before switching the equipment on. Prevent contact with live parts at any time.
    - ⇒ A residual-current-operated protective device (RCD) must not be used on electric drives! Indirect contact must be prevented by other means, for example, by an overcurrent protective device.
    - ⇒ Electrical components with exposed live parts and uncovered high voltage terminals must be installed in a protective housing, for example, in a control cabinet.
-

To be observed with electrical drive and filter components:



**DANGER**

**High electrical voltage on the housing!  
High leakage current! Danger to life, danger of  
injury by electric shock!**

- ⇒ Connect the electrical equipment, the housings of all electrical units and motors permanently with the safety conductor at the ground points before power is switched on. Look at the connection diagram. This is even necessary for brief tests.
- ⇒ Connect the safety conductor of the electrical equipment always permanently and firmly to the supply mains. Leakage current exceeds 3.5 mA in normal operation.
- ⇒ Use a copper conductor with at least 10 mm<sup>2</sup> cross section over its entire course for this safety conductor connection!
- ⇒ Prior to startups, even for brief tests, always connect the protective conductor or connect with ground wire. Otherwise, high voltages can occur on the housing that lead to electric shock.

### 3.6 Protection Against Electric Shock by Protective Low Voltage (PELV)

All connections and terminals with voltages between 0 and 50 Volts on Rexroth products are protective low voltages designed in accordance with international standards on electrical safety.



**WARNING**

**High electrical voltage due to wrong  
connections! Danger to life, bodily harm by  
electric shock!**

- ⇒ Only connect equipment, electrical components and cables of the protective low voltage type (PELV = Protective Extra Low Voltage) to all terminals and clamps with voltages of 0 to 50 Volts.
- ⇒ Only electrical circuits may be connected which are safely isolated against high voltage circuits. Safe isolation is achieved, for example, with an isolating transformer, an opto-electronic coupler or when battery-operated.

## 3.7 Protection Against Dangerous Movements

Dangerous movements can be caused by faulty control of the connected motors. Some common examples are:

- improper or wrong wiring of cable connections
- incorrect operation of the equipment components
- wrong input of parameters before operation
- malfunction of sensors, encoders and monitoring devices
- defective components
- software or firmware errors

Dangerous movements can occur immediately after equipment is switched on or even after an unspecified time of trouble-free operation.

The monitoring in the drive components will normally be sufficient to avoid faulty operation in the connected drives. Regarding personal safety, especially the danger of bodily injury and material damage, this alone cannot be relied upon to ensure complete safety. Until the integrated monitoring functions become effective, it must be assumed in any case that faulty drive movements will occur. The extent of faulty drive movements depends upon the type of control and the state of operation.



### **Dangerous movements! Danger to life, risk of injury, severe bodily harm or material damage!**

- ⇒ Ensure personal safety by means of qualified and tested higher-level monitoring devices or measures integrated in the installation. Unintended machine motion is possible if monitoring devices are disabled, bypassed or not activated.
- ⇒ Pay attention to unintended machine motion or other malfunction in any mode of operation.
- ⇒ Keep free and clear of the machine's range of motion and moving parts. Possible measures to prevent people from accidentally entering the machine's range of motion:
  - use safety fences
  - use safety guards
  - use protective coverings
  - install light curtains or light barriers
- ⇒ Fences and coverings must be strong enough to resist maximum possible momentum, especially if there is a possibility of loose parts flying off.
- ⇒ Mount the emergency stop switch in the immediate reach of the operator. Verify that the emergency stop works before startup. Don't operate the machine if the emergency stop is not working.
- ⇒ Isolate the drive power connection by means of an emergency stop circuit or use a starting lockout to prevent unintentional start.
- ⇒ Make sure that the drives are brought to a safe standstill before accessing or entering the danger zone. Safe standstill can be achieved by switching off the power supply contactor or by safe mechanical locking of moving parts.

- ⇒ Secure vertical axes against falling or dropping after switching off the motor power by, for example:
  - mechanically securing the vertical axes
  - adding an external braking/ arrester/ clamping mechanism
  - ensuring sufficient equilibration of the vertical axes
 The standard equipment motor brake or an external brake controlled directly by the drive controller are not sufficient to guarantee personal safety!
- ⇒ Disconnect electrical power to the equipment using a master switch and secure the switch against reconnection for:
  - maintenance and repair work
  - cleaning of equipment
  - long periods of discontinued equipment use
- ⇒ Prevent the operation of high-frequency, remote control and radio equipment near electronics circuits and supply leads. If the use of such equipment cannot be avoided, verify the system and the installation for possible malfunctions in all possible positions of normal use before initial startup. If necessary, perform a special electromagnetic compatibility (EMC) test on the installation.

### 3.8 Protection Against Magnetic and Electromagnetic Fields During Operation and Mounting

Magnetic and electromagnetic fields generated near current-carrying conductors and permanent magnets in motors represent a serious health hazard to persons with heart pacemakers, metal implants and hearing aids.



**WARNING**

#### **Health hazard for persons with heart pacemakers, metal implants and hearing aids in proximity to electrical equipment!**

- ⇒ Persons with heart pacemakers, hearing aids and metal implants are not permitted to enter the following areas:
  - Areas in which electrical equipment and parts are mounted, being operated or started up.
  - Areas in which parts of motors with permanent magnets are being stored, operated, repaired or mounted.
- ⇒ If it is necessary for a person with a heart pacemaker to enter such an area, then a doctor must be consulted prior to doing so. Heart pacemakers that are already implanted or will be implanted in the future, have a considerable variation in their electrical noise immunity. Therefore there are no rules with general validity.
- ⇒ Persons with hearing aids, metal implants or metal pieces must consult a doctor before they enter the areas described above. Otherwise, health hazards will occur.

### 3.9 Protection Against Contact with Hot Parts

---



CAUTION

**Housing surfaces could be extremely hot!  
Danger of injury! Danger of burns!**

- ⇒ Do not touch housing surfaces near sources of heat! Danger of burns!
  - ⇒ After switching the equipment off, wait at least ten (10) minutes to allow it to cool down before touching it.
  - ⇒ Do not touch hot parts of the equipment, such as housings with integrated heat sinks and resistors. Danger of burns!
- 

### 3.10 Protection During Handling and Mounting

Under certain conditions, incorrect handling and mounting of parts and components may cause injuries.

---



CAUTION

**Risk of injury by incorrect handling! Bodily harm caused by crushing, shearing, cutting and mechanical shock!**

- ⇒ Observe general installation and safety instructions with regard to handling and mounting.
  - ⇒ Use appropriate mounting and transport equipment.
  - ⇒ Take precautions to avoid pinching and crushing.
  - ⇒ Use only appropriate tools. If specified by the product documentation, special tools must be used.
  - ⇒ Use lifting devices and tools correctly and safely.
  - ⇒ For safe protection wear appropriate protective clothing, e.g. safety glasses, safety shoes and safety gloves.
  - ⇒ Never stand under suspended loads.
  - ⇒ Clean up liquids from the floor immediately to prevent slipping.
-

## 3.11 Battery Safety

Batteries contain reactive chemicals in a solid housing. Inappropriate handling may result in injuries or material damage.



### Risk of injury by incorrect handling!

- ⇒ Do not attempt to reactivate discharged batteries by heating or other methods (danger of explosion and cauterization).
- ⇒ Never charge non-chargeable batteries (danger of leakage and explosion).
- ⇒ Never throw batteries into a fire.
- ⇒ Do not dismantle batteries.
- ⇒ Do not damage electrical components installed in the equipment.

**Note:** Be aware of environmental protection and disposal! The batteries contained in the product should be considered as hazardous material for land, air and sea transport in the sense of the legal requirements (danger of explosion). Dispose batteries separately from other waste. Observe the legal requirements in the country of installation.

## 3.12 Protection Against Pressurized Systems

Certain motors and drive controllers, corresponding to the information in the respective Project Planning Manual, must be provided with pressurized media, such as compressed air, hydraulic oil, cooling fluid and cooling lubricant supplied by external systems. Incorrect handling of the supply and connections of pressurized systems can lead to injuries or accidents. In these cases, improper handling of external supply systems, supply lines or connections can cause injuries or material damage.



### Danger of injury by incorrect handling of pressurized systems !

- ⇒ Do not attempt to disassemble, to open or to cut a pressurized system (danger of explosion).
- ⇒ Observe the operation instructions of the respective manufacturer.
- ⇒ Before disassembling pressurized systems, release pressure and drain off the fluid or gas.
- ⇒ Use suitable protective clothing (for example safety glasses, safety shoes and safety gloves)
- ⇒ Remove any fluid that has leaked out onto the floor immediately.

**Note:** Environmental protection and disposal! The media used in the operation of the pressurized system equipment may not be environmentally compatible. Media that are damaging the environment must be disposed separately from normal waste. Observe the legal requirements in the country of installation.

## Notes

## 4 Technical Data

### 4.1 Basic Device

	VAM 10.1	VAM 40.1
Degree of protection	IP 54 (front) Type 1 according to NEMA (UL)	
Protection class	1 according to DIN EN 50178	
Color of the front foil	RAL 7035 light gray	
Dimensions (W x H x D)	350 mm x 169 mm x 102 mm	407 mm x 169 mm x 102 mm
Mounting cut-out (W x H)	318 mm x 137 mm	375 mm x 137 mm
Installation depth	77 mm (including PROFIBUS DP connector)	
Weight	Approx. 1,170 g	Approx. 1,380 g
Material of the front panel	Varnished aluminium front panel with holohedrally let in chemical resistant polyester foil	

Fig. 4-1: General technical data

	VAM 10.1	VAM 40.1
Power supply	Electrically isolated	
Logic supply $U_L$	24 V DC (19,2 ... 30 V), PELV	
Current consumption by $U_L$	0,5 A max.	
Input/Output supply $U_Q$	24 V DC (19,2 ... 30 V), PELV	
Power consumption by $U_Q$	1.7 A max.	
Fuse	SMD fuse 3 A	
Reverse voltage protection	Integrated	

Fig. 4-2: Electrical data

**Note:** Continuous operation outside the range of 19,2 V to 30 V is not permissible and may cause the destruction of the filter choke in the input area!

D-SUB female connector strips, 25-pin, 9-pin
Male connector strips, by Weidmüller, 4-pin, 6-pin and 8-pin

Fig. 4-3: Connection method

## 4.2 Key Switch

- General Specifications:**
- 1-pin
  - 4-stage
  - Removal only in left position (position 1)
  - Contacts electrically isolated
  - Forced opening contact

**Contact Assignment  
of the Key Switch**

Position	Contacts closed
1	1-2
2	5-6
3	7-8
4	3-4

Fig. 4-4: Contact assignment of the key switch

Vendor	Kraus & Naimer	
Vendor's designation	CG4 D-243P*01 FS1	
Max. connection cross section	One or multiple wire	2 x 1.5 mm <sup>2</sup> 2 x AWG 14
	Fine wire	2 x 1.5 mm <sup>2</sup> 2 x AWG 16
A. C. values according to IEC EN 60947-3, VDE 0660 Part 107		
~AC-15	110 V – 110 V 220 V – 240 V	2.5 A 2.5 A
D. C. values Ohmic circuits (T ≤ 1 ms)		
D. C. switching capacity	24 V 48 V	10 A 6 A
D. C. values inductive circuits (T ≤ 50 ms)		
D. C. switching capacity	24 V 48 V	6 A 1 A
For further information please refer to the data sheet of the vendor		

Fig. 4-5: Technical data of the key switch

### 4.3 Machine Pushbutton and E-STOP

Vendor	Télemecanique (Schneider Electric)	
Vendor's designation	Standard auxiliary switch, NO contact Standard auxiliary switch, NC contact (with forced opening) LED module 24 V	ZBE-101 ZBE-102  ZBV-B1
Connection cross-section	Min. without connector sleeve Max. without connector sleeve	1 x 0.22 mm <sup>2</sup> 2 x 1.5 mm <sup>2</sup>
LED module with rated voltage 24 V <b>ZBV-B1</b>		
Voltage range	AC DC	21.6 V – 26.4 V 19.2 V – 30 V
Power consumption	Direct connection 24 V AC / DC	18 mA
NO contact <b>ZBE 101</b> and NC contact <b>ZBE-102</b> according to IEC / EN 60947-6-1		
~AC-15	240 V 120 V	3 A 6 A
=DC-13	250 V 125 V	0.27 A 0.55 A
For further information please refer to the data sheet of the vendor		

Fig. 4-6: Technical data for machine pushbutton and E-STOP

### 4.4 Ambient Conditions

	Operation	Storage
Ambient temperature (surrounding air temperature)	+5 °C to +55 °C	-25 °C to +70 °C
Relative humidity	10 % to 95 %, non-condensing	10 % to 95 %, non-condensing
Air pressure	Up to 2000 m above MSL	Up to 3,000 m above MSL
Degree of pollution	1	
Maximum vibration	5 Hz to 9 Hz: 1,75 mm amplitude (permanently) 3,50 mm amplitude (occasionally) 9 Hz to 150 Hz: 0,5 g acceleration (permanently) 1,0 g acceleration (occasionally)	
Maximum shock	15 g (occasional peak value above 11 ms, half sine wave)	

Fig. 4-7: Ambient conditions

## 4.5 Used Standards

The system components of the machine operator terminals VAM 10.1 and VAM 40.1 correspond to the following standards:

DIN EN 61131-2	Programmable logic controllers Part 2: Equipment requirements and tests	May 2003
DIN EN 61000-6-4	Electromagnetic compatibility (EMC) Part 6-4: Special basic standard – Emitted interference for the industrial area	Aug 2002
DIN EN 61000-6-2	Electromagnetic compatibility (EMC) Part 6-2: Special basic standard – Noise immunity for the industrial area	Aug 2002
DIN-EN-60529	Degrees of protection by the housing	Sep 2000
DIN EN -60204-1	Electrical equipment of machines Part 1: General requirements	Nov 1998

Fig. 4-8: Used standards

---

**CE Marking** **Note:** Concerning delivered VAM 10.1 and VAM 40.1 devices the CE requirements are fulfilled.

---

**UL/CSA Certification** The devices of the VAM family are certificated according to

- **UL508** (Industrial Control Equipment) and
- **C22.2 No. 14-M95** (CSA)



---

**Note:** To guarantee an UL/CSA-compliant operation, you have to fulfill the following conditions:

- Use 60/75 °C copper wire only.
- Use Class 1 wire only or equivalent.

---

**Note:** The UL/CSA marking is only valid for the device in its delivery status. After having modified the device the UL compliancy has to be verified.

---

## 4.6 Compatibility Test

All Rexroth controls and drives are developed and tested according to the latest state-of-the-art.

As it is impossible to follow the continuing development of all materials (e.g. lubricants in machine tools) which may interact with our controls and drives, it cannot be completely ruled out that any reactions with the materials used by Bosch Rexroth might occur.

For this reason, before using the respective material a compatibility test has to be carried out for new lubricants, cleaning agents etc. and our housings/our housing materials.

# 5 Dimensions

## 5.1 Housing Dimensions

### Housing Dimensions VAM 10.1, Front, Side and Top View

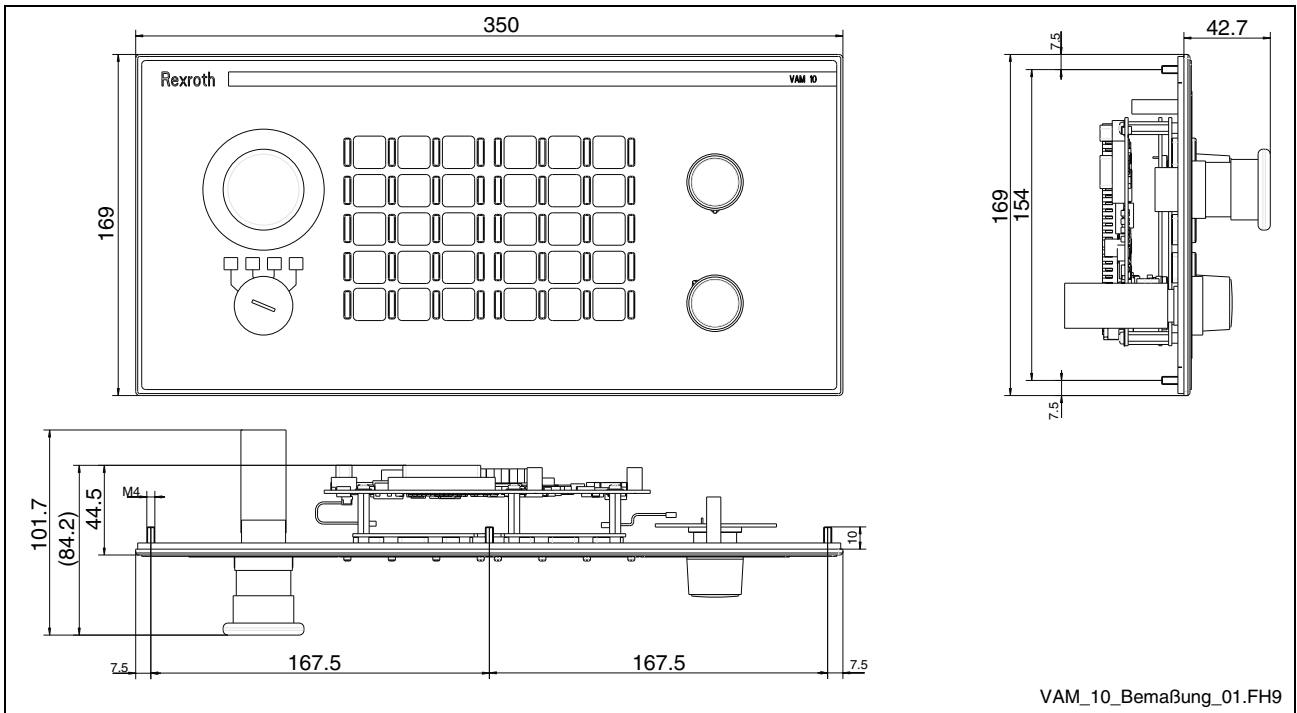

Fig. 5-1: Housing dimensions VAM 10.1, front, side and top view

### Housing Dimensions VAM 10.1, Rear View

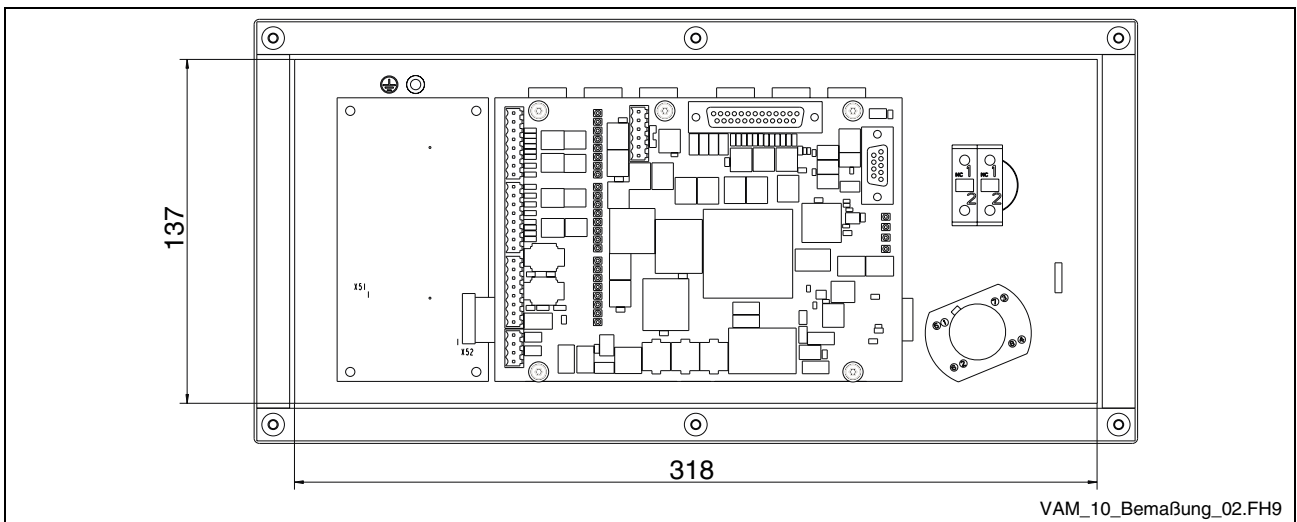

Fig. 5-2: Housing dimensions VAM 10.1, rear view

### Housing Dimensions VAM 40.1, Front, Side and Top View

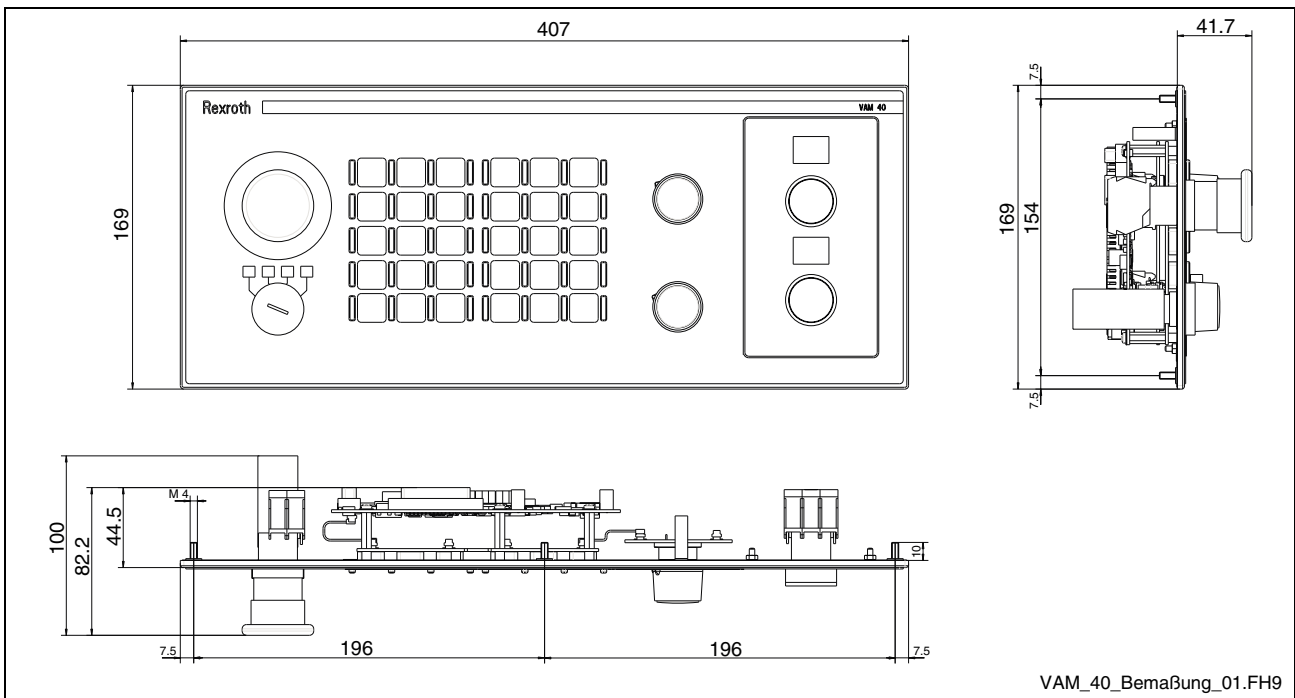

Fig. 5-3: Housing dimensions VAM 40.1, front, side and top view

### Housing Dimensions VAM 40.1, Rear View

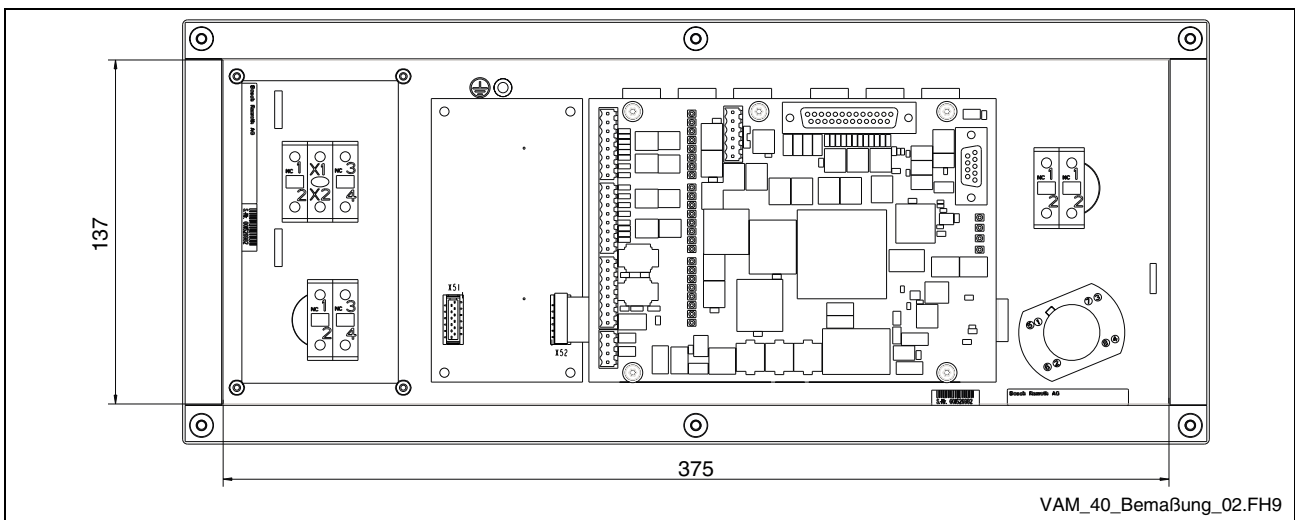

Fig. 5-4: Housing dimensions VAM 40.1, rear view

## 5.2 Installation

### Installation Notes

- When installing the operator panel , observe to ensure an ergonomic operation. Additionally, ensure that all moving machine components are in sight of the operator.
- Avoid installation locations exposed to direct sunlight, as additional heat development can occur.
- Install the operator panel in a manner ensuring easy access to the front panel (top side).
- Observe that the LED displays on the front panel are not obstructed.
- Provide a sufficient minimum clearance of 50 mm for cooling and cable routing behind the device.
- Lay all connecting cables in loops and use strain reliefs for all cables.
- Keep a suitably large distance from sources of interference.

### Mounting Cut-Out

For mounting the operator panel proceed as follows:

1. Create a mounting cut-out with 6 holes, diameter 4.5 mm, according to the illustrations "Mounting dimensions" on the following page.
2. Insert the operator panel from the front into the cut-out. Then insert the mounting bolts M4 into the drilled holes.
3. Fasten the operator panel by screwing the nuts at the rear side of the mounting bolts.

### Mounting Dimensions VAM 10.1

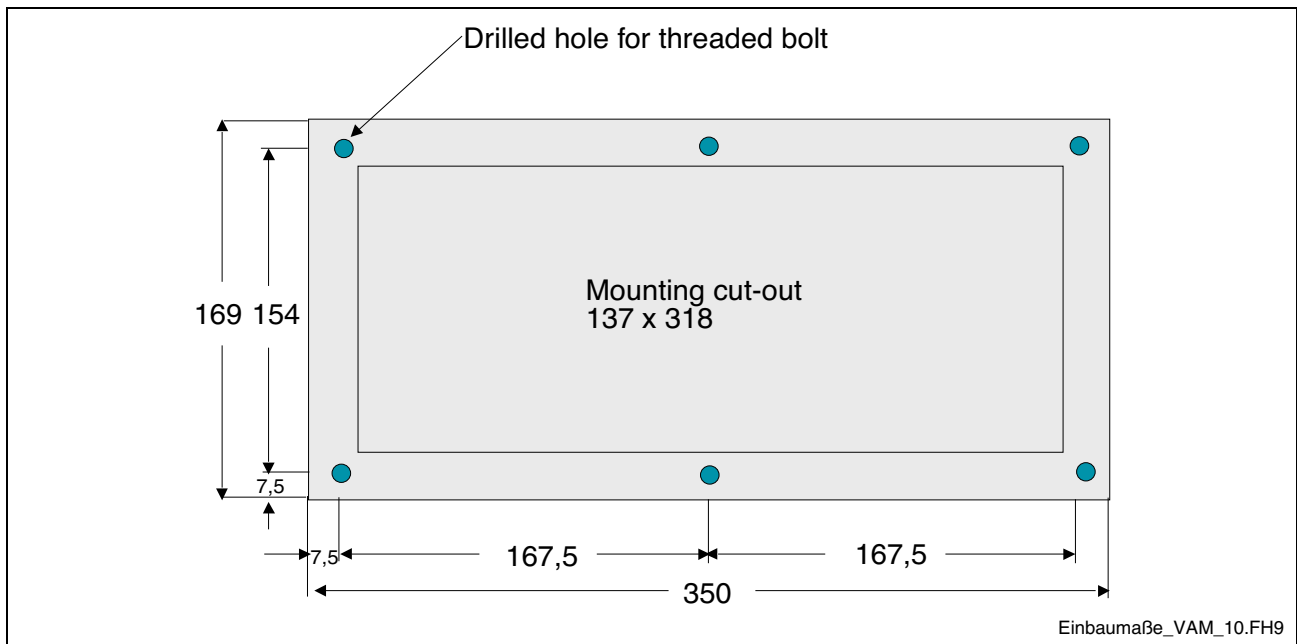

Fig. 5-5: Mounting dimensions VAM 10.1

### Mounting Dimensions VAM 40.1

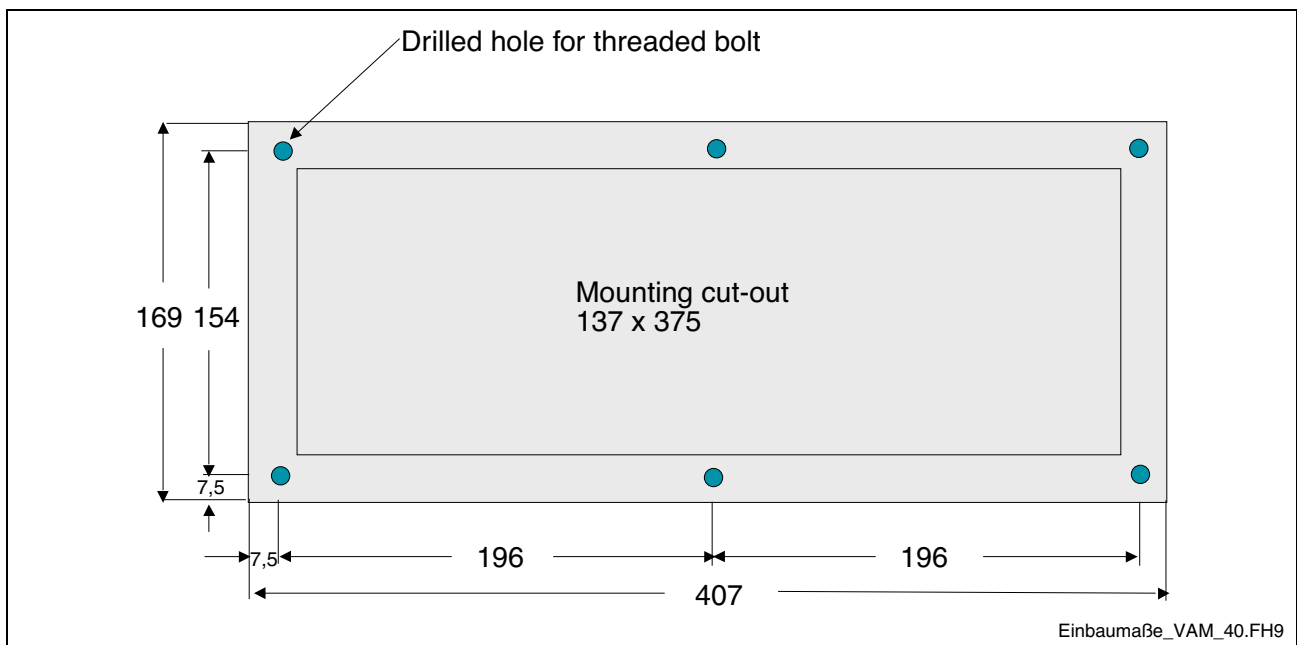

Fig. 5-6: Mounting dimensions VAM 40.1

## 6 Module Layout

### 6.1 General Information

#### Labeling Templates for Slide-In Strips

Labeling templates are published via the Internet and can be downloaded under [http://www.boschrexroth.com/BoschRexroth/business\\_units/brc/en/downloads\\_uebersicht\\_de/index.jsp](http://www.boschrexroth.com/BoschRexroth/business_units/brc/en/downloads_uebersicht_de/index.jsp).

The icons to label the machine function keys can be inserted in the templates and be printed on transparent foil with the help of a laser printer.

---

**Note:** If it is not possible to print on foils, the template can be printed on paper and then copied on foil.

---

After cutting out the slide-in strips, they can be inserted on the rear side of the devices.

### 6.2 Basic Device

---

**Note:** As the VAM 10.1 is equal to the basis device of the VAM 40.1, the former is not separately described.

---

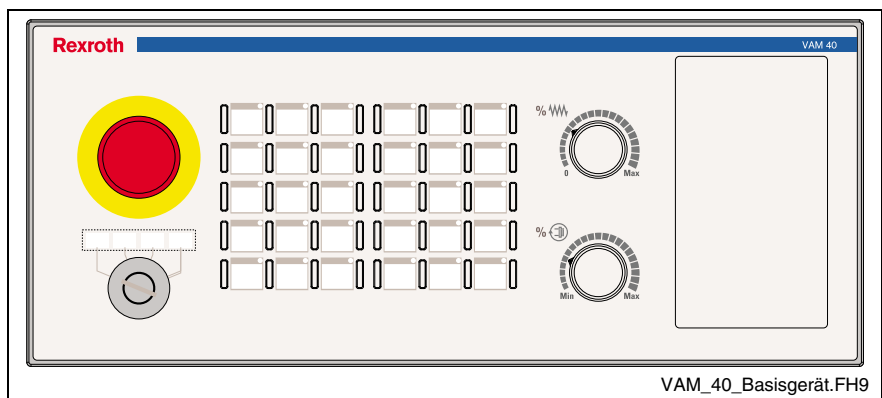

Fig. 6-1: Basic device

---

**Note:** VAM-type device are delivered without rear covering plate.

---

## E-STOP and Key Switch

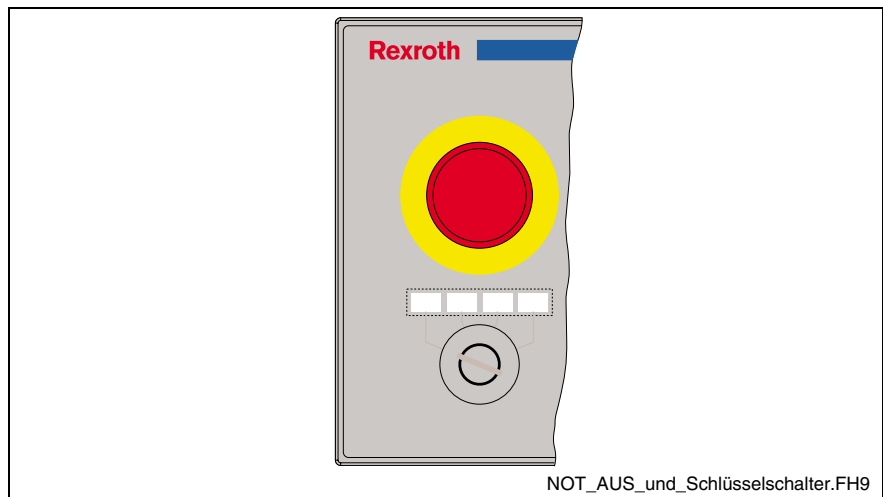

Fig. 6-2: E-STOP and key switch

This module slot is equipped with a non-wired standard E-STOP pushbutton. The two NC contacts of the switching elements can be wired with the E-STOP circuits of the machine as required.

Additionally, the module slot is provided with a 4-stage key switch with slide-in strips for individual labeling. The key switch has force-guided and electrically isolated contacts. The key is removable if it is situated on the left side (position 1).

Position	Contacts closed
1	1-2
2	5-6
3	7-8
4	3-4

## Keypads

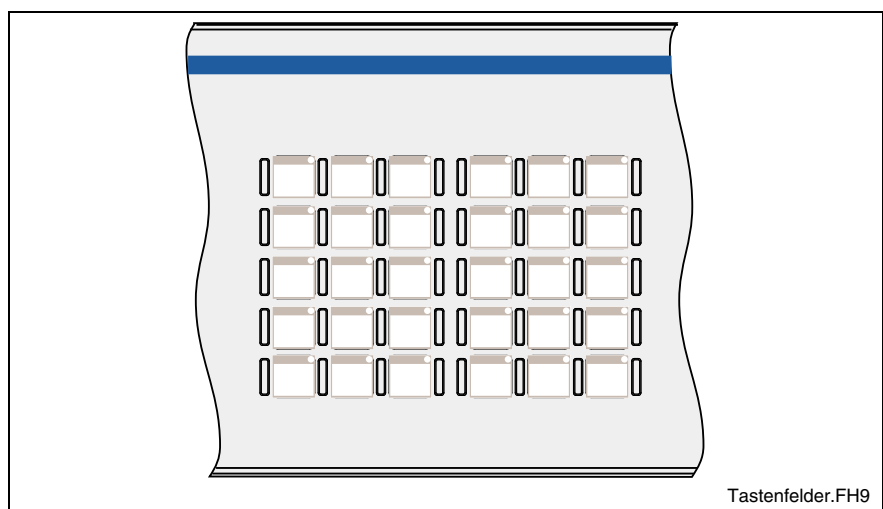

Fig. 6-3: Keypads

Two keypads each provided with 15 keys are available. The keys are short-stroke keys and can be configured and labeled according to the system requirements. The keys are covered by a foil arranged in a matrix containing three columns and five rows for each keypad. Each key is illuminated by a green point LED.

There are separators between the keys preventing the user from accidental key activation, as they separate clearly one key from each other.

The module is connected to the logic board via the internal shift register bus. The states of the pushbuttons are transmitted to the master control via PROFIBUS DP. The LEDs are triggered via PROFIBUS DP by the master control.

---

**Note:** The module configuration as well as the address assignment is described in chapter 8 "Commissioning".

---

## Override Rotary Switch

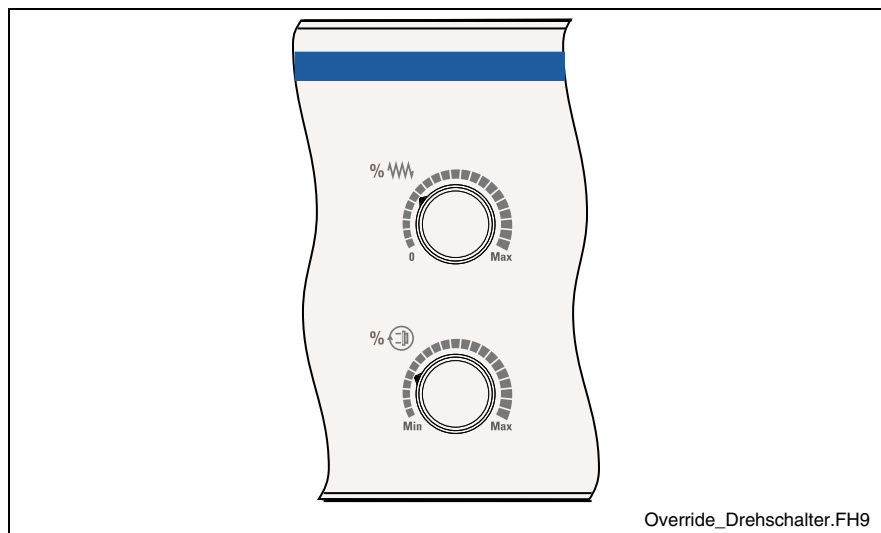

Fig. 6-4: Override rotary switch

This module slot is equipped with two override rotary switches. The feed override has 16 switching positions ranging from "0 to Max", the spindle override has also 16 switching positions ranging from "Min to Max".

The module is connected to the logic board via the internal shift register bus. The switching positions of the pushbuttons are transmitted to the master control via PROFIBUS DP.

---

**Note:** The module configuration as well as the address assignment is described in chapter 8 "Commissioning".

---

## 6.3 Modules

### Quick STOP Module

The machine pushbuttons can be customer-specific wired.

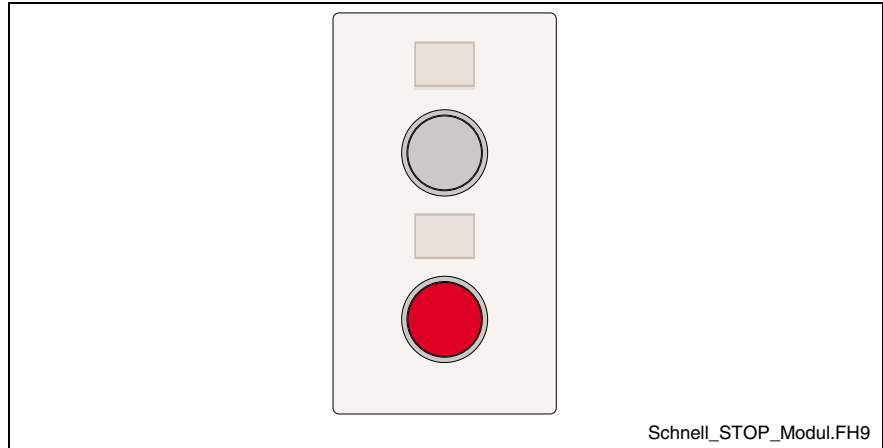

Fig. 6-5: Quick STOP module

The quick STOP module is provided with a white lit and a red unlit machine pushbutton. The two pushbuttons can be user-specific labeled with a labeling strip.

The white lit machine pushbutton has a NC contact (contact designation 1 and 2), a NO contact (contact designation 3 and 4) and a 24 V LED (contact designation X1 and X2).

The unlit red machine pushbutton provides only a NC contact (contact designation 1 and 2) and a NO contact (contact designation 3 and 4).

### Further Modules

In future, e. g. a handwheel module or a blind plate are provided for the fifth module slot.

## 7 Interfaces

### 7.1 Connector Panel



Abb. 7-1: View on the connector panel (VAM 40.1)

### 7.2 Protective Earth Terminal

Ensure that during the wiring of the protective conductor the wire cross-section is sufficient. For this, consider also EN 60204 Part 1 (max. electric resistance and verification of the protective conductor's wiring).

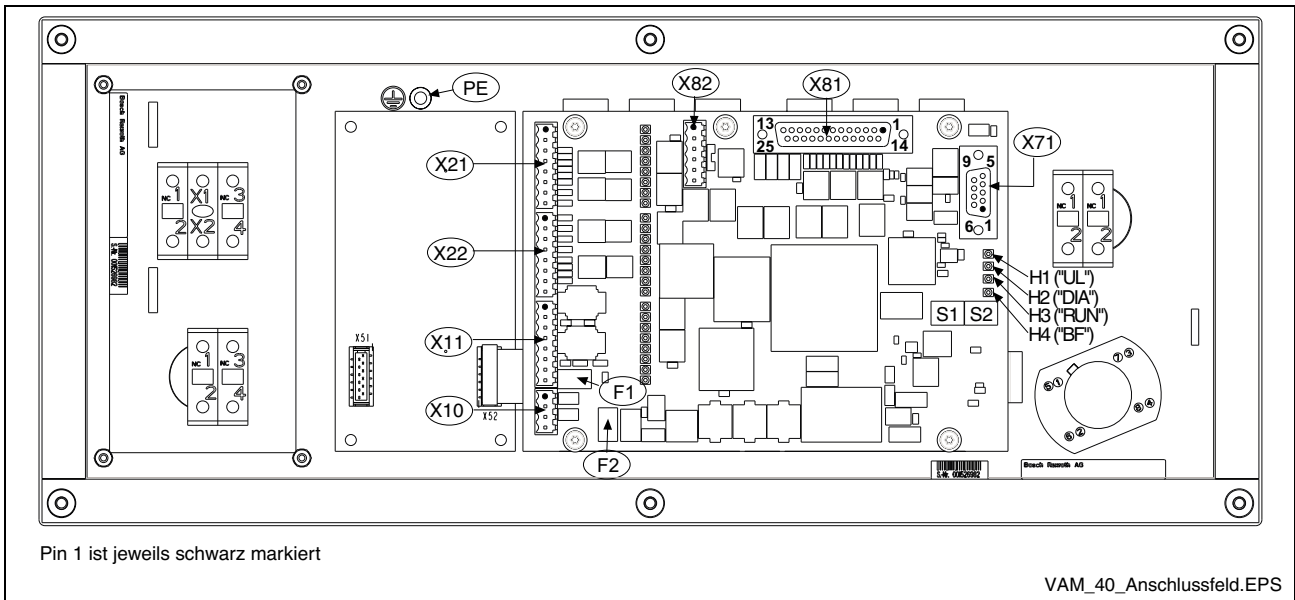

**DANGER**

**Dangerous shock currents caused by insufficient protective conductor connections!**

⇒ Protective conductor connections must not be affected by mechanical, chemical or electrochemical influences. The connection must be durable.

## 7.3 Current and Voltage Supply (X10)

**4-pin Weidmüller Male Connector** A 4-pin Weidmüller male connector (3.5 grid) with the following pin assignment serves to connect the voltage supply:

Connector	Pin	Signal	Meaning
X10	1	U <sub>Q</sub>	+24 V DC Input/Output supply U <sub>Q</sub>
	2	0 V U <sub>Q</sub>	0 V Input/Output supply U <sub>Q</sub>
	3	U <sub>L</sub>	+24 V DC Logic supply U <sub>L</sub>
	4	0 V U <sub>L</sub>	0 V Logic supply U <sub>L</sub>

Fig. 7-2: Pin assignment X10

**Fuses** The supplies at X10 are protected by two SMD fuses F1 and F2.

Supply	Fuse	Fuse drops
U <sub>Q</sub>	F1	<ul style="list-style-type: none"> <li>• Simultaneous short-circuit of several outputs (connector 11) against 0 V</li> <li>• Simultaneous exceeding of I = 200 mA at several outputs (X11)</li> <li>• Hardware defect</li> </ul>
U <sub>L</sub>	F2	<ul style="list-style-type: none"> <li>• Short-circuit of the hand-held terminal's +24 V supply (connector X81, pin 1 or pin 14) against 0 V</li> <li>• Hardware defect</li> </ul>

Vendor:	By Littlefuse
Vendor's designation:	451003. (FF3A)

Fig. 7-3: Fuses

## 7.4 Field Bus Interface PROFIBUS DP (X71)

Connector X71 provides at connection VP 5 V / 100 mA ISO voltage. Do not use any bus terminating resistors, but only a bus load. Thus, the connection of a hand-held terminal or an Optical Link Plug (OLP) [conversion RS485/Opto] is possible. Optical PROFIBUS networks in ring topology can be established with the help of the OLP.

### General Information

Type	RS485
Electrical isolation	Yes
Baud rate	Up to 12 Mbauds
2 BCD rotary switches	Station address 1-99
Connector X71	9-pin female connector strip D-SUB

Fig. 7-4: Field bus interface PROFIBUS DP according to EN 50170, Part 2 (DP)

### Pin Assignment

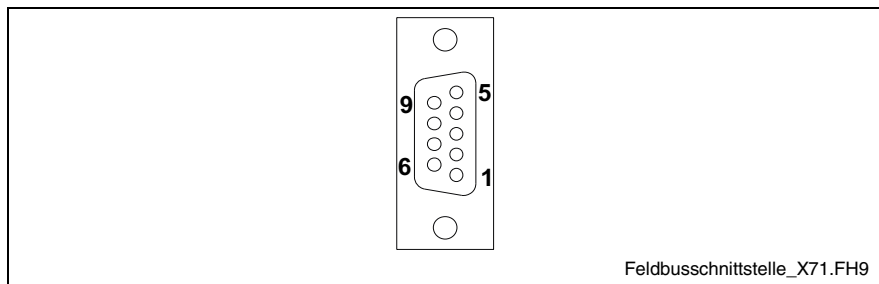

Fig. 7-5: Pin assignment of the PROFIBUS DP interface

Connector	Pin	RS485 reference	Signal	Meaning
X71	1	-	-	-
	2	-	-	-
	3	B/B'	RxD/TxD-P	Receiving/Transmitting data
	4		CNTR_P	Repeater control signal
	5	C/C'	DGND	Data reference potential (M 5 V)
	6		VP	Supply voltage plus (P 5 V)
	7	-	-	-
	8	A/A'	RxD/TxD-N	Receiving/Transmitting data N
	9		DGND	Data reference potential (M 5 V)

Fig. 7-6: Pin assignment of the PROFIBUS DP interface

**Note:** Ensure that potential equalizing currents don't flow over the shield conductor of the interface line. Therefore, provide for a proper potential equalization between the devices to be connected already before the first commissioning.

## 7.5 Digital 24 V Inputs and Outputs (X21, X22, X11)

The VAM 10.1 / VAM 40.1 provide 16 digital 24 V inputs and 8 digital 24 V outputs. The connectors of the inputs and outputs are on the logic board. The states of the I/Os are indicated by the green LED.

The states of the inputs are transmitted to the master control via PROFIBUS DP. The outputs are defined by the master control via PROFIBUS DP.

---

**Note:** The module configuration as well as the address assignment is described in chapter 8 "Commissioning".

---

### Pin Assignment (3 x 8-Pin Weidmüller Connector (3.5 Grid))

Connector	Pin	Signal	Meaning
X21	1	I0	Digital 24 V inputs I 0 – I 7
	2	I1	
	3	I2	
	4	I3	
	5	I4	
	6	I5	
	7	I6	
	8	I7	
X22	1	I8	Digital 24 V inputs I 8 – I 15
	2	I9	
	3	I10	
	4	I11	
	5	I12	
	6	I13	
	7	I14	
	8	I15	
X11	1	Q0	Digital 24 V outputs Q 0 – Q 7
	2	Q1	
	3	Q2	
	4	Q3	
	5	Q4	
	6	Q5	
	7	Q6	
	8	Q7	

Fig. 7-7: Pin assignment X21, X22, X11

---

**Note:** The plug-in connectors for the inputs and the outputs must not be connected or disconnected under load.

---

## Characteristics of Digital Inputs

Input type	Type 1, according to EN 61131-2
Number of inputs	16
Status display by LED	Green
Electrical isolation	Yes (to logic supply)
Reverse voltage protection	Yes
Plug-in grid	3,5 (Weidmüller terminal)

Fig. 7-8: Characteristics of digital inputs

## Characteristics of Digital Outputs

Output type	Semiconductor outputs, non-saving; protected, with automatic restart, current-carrying
Number of outputs	8
Status display by LED	Green
Electrical isolation	Yes (to logic supply)
Reverse voltage protection	Only guaranteed without load connection Defect of the assembly because of <ul style="list-style-type: none"> <li>• Polarity reversal with simultaneous short-circuit of the output lines,</li> <li>• Polarity reversal with simultaneous connection of externally polarized suppressor diodes at the output lines</li> <li>• Applying an external voltage &gt; <math>U_Q</math></li> </ul>
Output voltage, nominal value	24 V
Rated output current nominal value: UL rating:	0,2 A 0,2A General Purpose 5W Tungsten
Simultaneity factor	100 %
Plug-in grid	3,5 (Weidmüller terminal)

Fig. 7-9: Characteristics of digital outputs

## 7.6 Connection for External Hand-Held Terminal (X81)

Besides the inputs for the handwheel of the hand-held terminal (A, /A, B, /B) 12 inputs (IN0 – IN11) for the keys of the hand-held terminal are available. The keys are supplied via the "+24 V" supply via connector X81. The "+24 V" supply is generated by the supply "UL" and may only be used to connect the keys of the hand-held terminal. Connection X81 for the hand-held terminal is located on the logic circuit.

The states of the inputs and the counter value of the handwheel are transmitted to the master control via PROFIBUS DP.

---

**Note:** The module configuration as well as the address assignment is described in chapter 8 "Commissioning".

---

## Pin Assignment (25-Pin Female Connector Strip D-SUB)

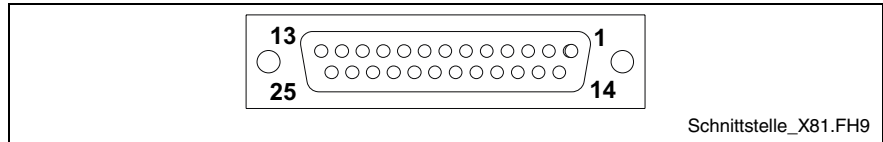

Fig. 7-10: Pin assignment X81

Connector	Pin	Signal	Meaning
X81	1	+24 V	+24 VDC supply for switch of the hand-held terminal
	2	IN 0	24 V input for switch of the hand-held terminal
	3	IN 2	24 V input for switch of the hand-held terminal
	4	IN 4	24 V input for switch of the hand-held terminal
	5	IN 6	24 V input for switch of the hand-held terminal
	6	IN 8	24 V input for switch of the hand-held terminal
	7	IN10	24 V input for switch of the hand-held terminal
	8	N.C.	Free
	9	N.C.	Free
	10	GND	0 V handwheel supply (-)
	11	+5 V	+5 VDC +/-5% handwheel supply (+)
	12	/B	Handwheel channel B inverse
	13	/A	Handwheel channel A inverse
	14	+24 V	+24 VDC supply for switch of the hand-held terminal
	15	IN 1	24 V input for switch of the hand-held terminal
	16	IN 3	24 V input for switch of the hand-held terminal
	17	IN 5	24 V input for switch of the hand-held terminal
	18	IN 7	24 V input for switch of the hand-held terminal
	19	IN 9	24 V input for switch of the hand-held terminal
	20	IN 11	24 V input for switch of the hand-held terminal
	21	N.C.	Free
	22	GND	0 V handwheel supply (-)
	23	+5V	+5 VDC +/-5% handwheel supply (+)
	24	B	Handwheel channel B
	25	A	Handwheel channel A

Fig. 7-11: Pin assignment X81

Handwheel supply	5 V DC +/- 5 %
Current consumption, handwheel	200 mA max.
Max. cable length	Approx. 5 m (depending on the handwheel)
Cable type	Twisted pair, separately shielded
Inputs	24 V input (for switch / pushbutton of the hand-held terminal)
Reference device	HBA 072910, by Euchner 100 pulses / revolution; max. 300/min

Fig. 7-12: Characteristics of the handwheel interface

## 7.7 Connection for Internal Handwheel (X82)

Connection X82 for the internal handwheel is located on the logic circuit. The counter value of the handwheel is transmitted to the master control via PROFIBUS DP.

---

**Note:** The module configuration as well as the address assignment is described in chapter 8 "Commissioning".

---

### Pin Assignment (6-Pin Weidmüller Connector (3.5 Grid))

Connector	Pin	Signal	Meaning
X82	1	+5 V	+5 VDC +/- 5 % handwheel supply (+)
	2	A	Handwheel channel A
	3	B	Handwheel channel B
	4	GND	0 V handwheel supply (-)
	5	/A	Handwheel channel A inverse
	6	/B	Handwheel channel B inverse

Fig. 7-13: Pin assignment X81

Reference device	Incremental handwheel IHE, by Jakob 100 pulses / revolution; max. 300/min power consumption 100 mA
------------------	--



## 8 Commissioning

### 8.1 GSD File

With the devices two GSD files according to EN 50170 Part 2 (DP) are provided. These files contain all data allowing to connect the assemblies VAM 10.1 and VAM 40.1 to any DP master (according to EN 50170 Part 2 (DP)). The master manufacturer delivers or defines a suitable DP configuration tool with its DP master.

**RX010123.GSD** is an universal GSD file describing the operator panels VAM 10.1 / VAM 40.1 (and further VAM operator panels) as modular DP slave. You can select this GSD file in the DP configuration tool via the station name "VAM". The modules must be configured in the DP configuration tool in the right order. The order of the modules is described in chapter 8.6.

**RX020123.GSD** is a GSD file describing the operator panels VAM 10.1 and VAM 40.1 as compact DP slave. This GSD file serves for easy configuration of the VAM 10.1 and as basic device of the VAM 40.1. If you select station name "VAM10,VAM40" in the DP configuration tool, the right configuration of the modules is automatically illustrated.

The GSD files are published via the Internet and can be downloaded under [http://www.boschrexroth.com/BoschRexroth/business\\_units/brc/en/downloads\\_uebersicht\\_de/index.jsp](http://www.boschrexroth.com/BoschRexroth/business_units/brc/en/downloads_uebersicht_de/index.jsp).

## 8.2 PROFIBUS DP Address Settings

The station address is set with 2 BCD rotary switches S1 and S2 (see figure below) for the station addresses 1-99. Thereby, S1 represents the tens digit and S2 the ones digit of the station address.

The address must be set in de-energized status.

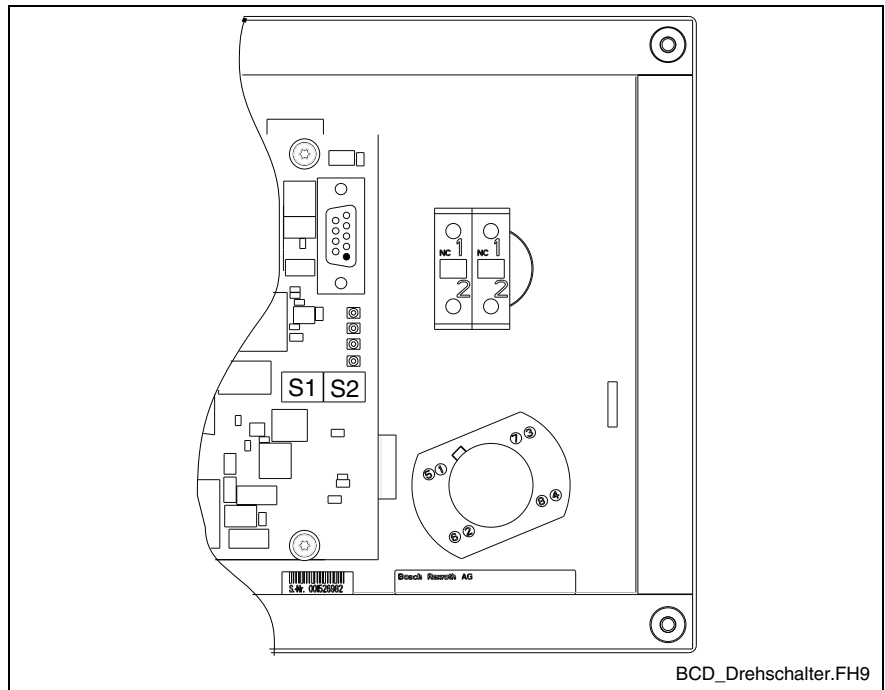

Fig. 8-1: BCD rotary switch S1 and S2

## 8.3 Baud Rate Setting

The machine operator panels VAM 10.1 and VAM 40.1 recognize automatically the baud rate set at the PROFIBUS DP. Supported are baud rates ranging from 9,6 kbauds to 12 Mbauds:

- 9.6 kbauds
- 19.2 kbauds
- 45.45 kbauds
- 93.75 kbauds
- 187.5 kbauds
- 500 kbauds
- 1.5 Mbauds
- 3 Mbauds
- 6 Mbauds
- 12 Mbauds

## 8.4 Status Displays

The following figure shows the four status displays H1-H4:

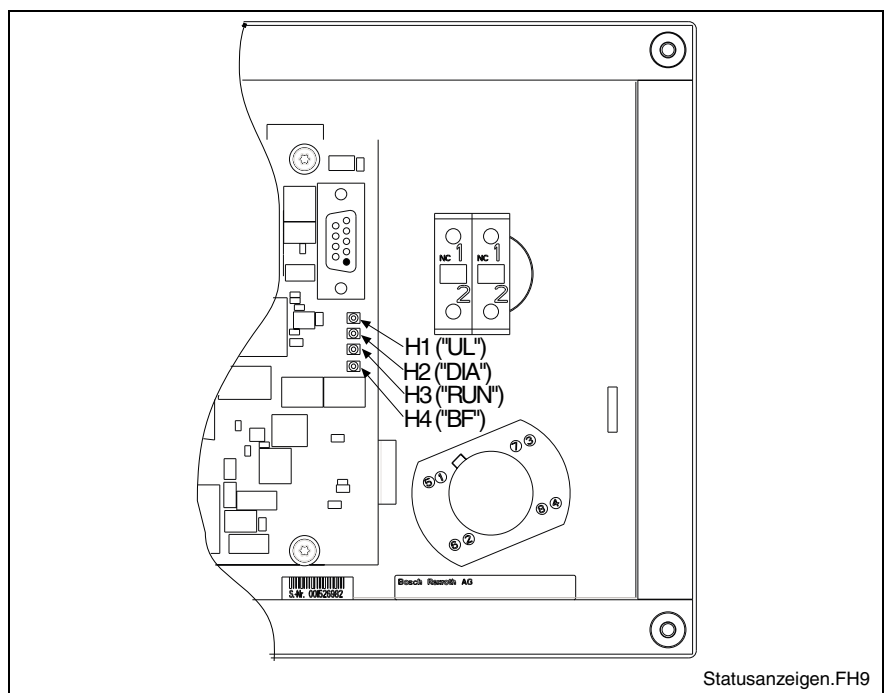

Fig. 8-2: Status displays H1-H4

Pos	Light-emitting diode	Display	Meaning
H1	"UL"	Green Green~ Green~~ Off	<u>24 V supply (connector X10)</u> 24 V supply is available The bus connection is kept in the initialization phase by one or several modules. System stop (see table system stop) No 24 V supply available
H2	"DIA"	Red Red~ Red~~ Off	<u>Diagnostic display</u> One or several modules indicate a diagnosis. System stop (see table system stop) System stop (see table system stop) No diagnosis or system stop
H3	"RUN"	Green Green~ Off	<u>Operating display</u> Cyclic I/O data exchange (normal operation) Configuration error (command/actual assignment is different) The bus connection is not activated by the DP master. Causes: <ul style="list-style-type: none"> <li>• Faulty PROFIBUS DP station address</li> <li>• The PROFIBUS DP station address is assigned several times at the bus.</li> <li>• The response monitoring time is expired.</li> <li>• Error in master parameter set (GSD file); e. g. wrong PNO-ID number, wrong buffer seize (Prm, Cfg, ...)</li> <li>• Incorrect parameterization in User_Prm_Data[1]</li> </ul>
H4	"BF"	Red Red~ Off	<u>Bus error</u> The bus connection is searching the baud rate. Parameterization error (invalid parameterization data) The bus connection has recognized and applied the baud rate.

L:      Green    static display  
          Green~   slow flashing of the display (0,8 s On / 0,2 s Off)  
          Green~~   slow flashing of the display (0.125 s On / 0.125 s Off)

Fig. 8-3: Status displays

## System Stop

The status "System stop" is indicated with the two light-emitting diodes "UL" and "DIA". During a system stop the outputs are set to the safe status ('0') and the bus traffic to the DP master is interrupted. The system stop can only be quit by a restart of the assembly ('Network on').

"UL"	'DIA'	Meaning	Measure
Off / green / green~	Off / red	No system stop	-
Green	Red~	Unknown I/O module	Load new firmware version (service case)
Green~~	Off	Misconfiguration	Verify I/O configuration
Off / green	Red~~	Exceptional error firmware	Service case
Green~~	Red~~	Exceptional error hardware	Service case

Fig. 8-4: Display of status "System stop"

### System Stop Unknown I/O Module

The VAM has recognized a module, that is not supported by the firmware version of the bus connection.

- To operate the I/O module the firmware must be updated.
- If an error occurs with the current firmware version, the module has a hardware error.

### System Stop 'Misconfiguration'

The following I/O configurations lead to a system stop because of a misconfiguration:

- No I/O modules equipped.
- More than 16 I/O modules equipped.
- More than 64 bytes inputs equipped.
- More than 64 bytes outputs equipped.
- The total of the parameterization data of all modules is greater than 64 bytes.
- The total of the parameterization data of all modules is greater than 64 bytes.

### Exceptional Error 'Hardware' (HW)

When booting ('Network on') the bus connection, the hardware components are tested. Furthermore, during the cyclic operation the I/O configuration and the transmission quality to the I/O modules are monitored. If an error occurs, the assembly is set to system stop 'Exceptional error HW'.

## 8.5 Address Assignment

### Keypads

Each key Sx.y (input) is assigned to a green LED Hx.y (output). The keypads are connected to the logic circuit via the internal shift register bus. The inputs (pushbuttons) and outputs (LEDs) of the keypad are mapped at the field bus in module "Keypad TA". For each of the keypads, 1 and 2, in the PROFIBUS configurator a module "Keypad\_TA" must be configured.

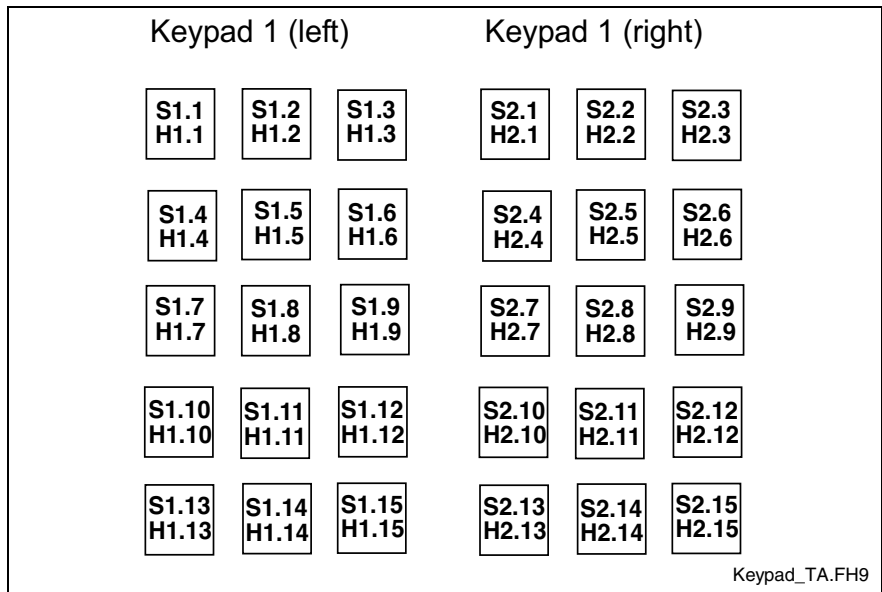

Fig. 8-5: Keypad TA

#### PROFIBUS DP Module for Keypad 1 (GSD File)

Keypad TA	Format	MSB							LSB
LED outputs	BYTE	H1.8	H1.7	H1.6	H1.5	H1.4	H1.3	H1.2	H1.1
	BYTE	-	H1.15	H1.14	H1.13	H1.12	H1.11	H1.10	H1.9
Key inputs	BYTE	S1.8	S1.7	S1.6	S1.5	S1.4	S1.3	S1.2	S1.1
	BYTE	0	S1.15	S1.14	S1.13	S1.12	S1.11	S1.10	S1.9

Fig. 8-6: I/O assignment of module keypad 1

#### PROFIBUS DP Module for Keypad 2 (GSD File)

Keypad TA	Format	MSB							LSB
LED outputs	BYTE	H2.8	H2.7	H2.6	H2.5	H2.4	H2.3	H2.2	H2.1
	BYTE	-	S2.15	S2.14	S2.13	S2.12	S2.11	S2.10	S2.9
Key inputs	BYTE	H2.8	H2.7	H2.6	H2.5	H2.4	H2.3	H2.2	H2.1
	BYTE	0	S2.15	S2.14	S2.13	S2.12	S2.11	S2.10	S2.9

Fig. 8-7: I/O assignment of module keypad 2

## Override Rotary Switch

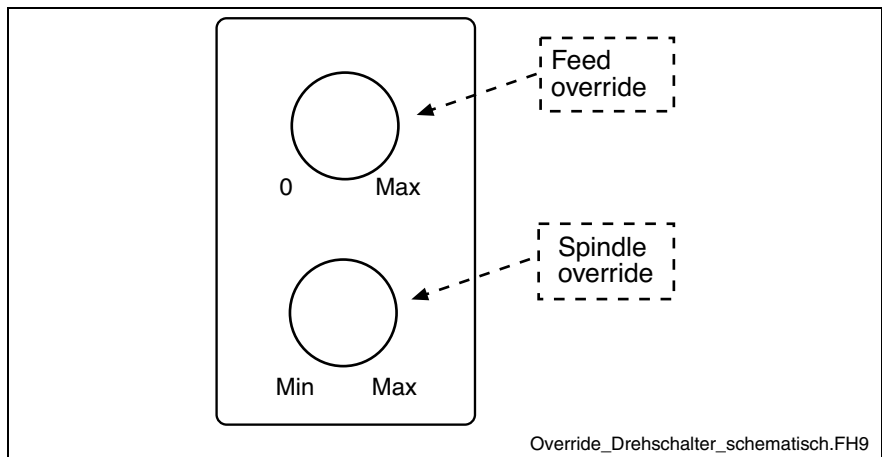

Fig. 8-8: Override rotary switch - schematic

The positions of the rotary switches (inputs) of the override module are mapped at the field bus in module "Override VB".

### Gray Code Table for both Override Rotary Switches

Position	D	C	B	A
0 (min)	0	0	0	0
1	0	0	0	1
2	0	0	1	1
3	0	0	1	0
4	0	1	1	0
5	0	1	1	1
6	0	1	0	1
7	0	1	0	0
8	1	1	0	0
9	1	1	0	1
10	1	1	1	1
11	1	1	1	0
12	1	0	1	0
13	1	0	1	1
14	1	0	0	1
15 (max)	1	0	0	0

Fig. 8-9: Gray code table

### PROFIBUS DP Module (GSD File)

Override VB	Format	MSB								LSB
Feed override	BYTE	0	0	0	0	D	C	B	A	
Spindle override	BYTE	0	0	0	0	D	C	B	A	

Fig. 8-10: Input assignment of module Override VB



## 8.6 Configuration Specification

**Note:** The following tables show how the modules must be configured in the PROFIBUS configurator depending on the type code.

### VAM 10.1-PB-NA-TA-TA-VB-1608-NN

To simplify the configuration, we recommend to use GSD file RX020123.GSD with station name "VAM10,VAM40".

Module no.	Module	Data format	Inputs (in bytes)	Outputs (in bytes)
0	16DI, 8DO	Byte	2	1
1	Manual Control Unit	Word	4	0
2	Handwheel	Word	2	0
3	Keypad TA	Byte	2	2
4	Keypad TA	Byte	2	2
5	Override VB	Byte	2	0

Fig. 8-14: VAM 10.1-PB-NA-TA-TA-VB-1608-NN

### VAM 40.1-PB-NA-TA-TA-VB-1608-NN

To simplify the configuration, we recommend to use GSD file RX020123.GSD with station name "VAM10,VAM40".

Module no.	Module	Data format	Inputs (in bytes)	Outputs (in bytes)
0	16DI, 8DO	Byte	2	1
1	Manual Control Unit	Word	4	0
2	Handwheel	Word	2	0
3	Keypad TA	Byte	2	2
4	Keypad TA	Byte	2	2
5	Override VB	Byte	2	0

Fig. 8-15: VAM 40.1-PB-NA-TA-TA-VB-1608-NN

## 8.7 Exemplary Configuration with IndraLogic

The example below shows the configuration "VAM10,VAM40" (RX020123.GSD) in combination with the configuration tool "IndraLogic".

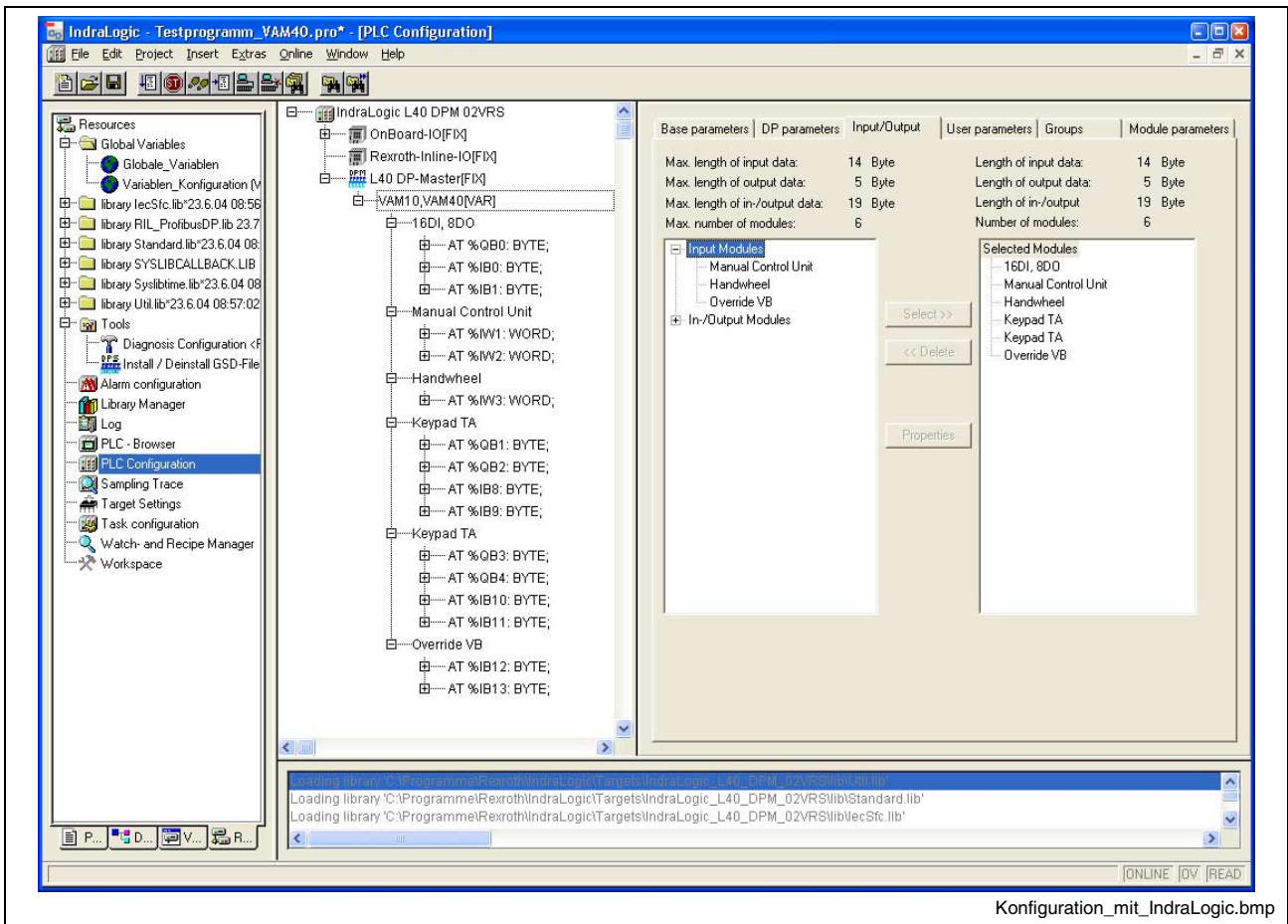



Fig. 8-16: Exemplary configuration with IndraLogic

# 9 Ordering Information

## 9.1 Type Code

Industrial Hydraulics | **Electric Drives and Controls** | Linear Motion and Assembly Technologies | Pneumatics | Service Automation | Mobile Hydraulics



Factory standard  
**VAM10.1**  
 Machine user terminal

**RNC 48121-001**  
 2004-03-01

---

User terminal

Replacement for  
RNC 48121-001 : 2003-07-29

Abbrev. Column	Configuration Module slot																														
	1	2	3	4	5	6	7	8	9	0	1	2	3	4	5	6	7	8	9	0	1	2	3	4	5	6	7	8	9	0	
Example:	V	A	M	.	1	0	.	1	-	P	B	-	N	A	-	T	A	-	T	A	-	V	B	-	1	6	0	8	-	N	N

**1. Product**  
 1.1 VAM. .... = VAM

**2. Line**  
 2.1 10 ..... = 10

**3. Design**  
 3.1 1 ..... = 1

**4. Communication bus**  
 4.1 PROFIBUS-DP ..... = PB

**5. Configuration 1 ①**  
 5.1 NA-TA-TA-VB  
 (Column: 12 to 13 = Module slot 1  
           15 to 16 = Module slot 2  
           18 to 19 = Module slot 3  
           21 to 22 = Module slot 4)

**6. Masterboard**  
 6.1 16 inputs and 8 outputs ..... = 1608

**7. Additional design**  
 7.1 none ..... = NN

**Note:**  
 ① Module slot 1 to 5  
 NA = Emergency-Stop module  
 MA = Quick-Stop module  
 TA = Keyboard, write onto  
 VB = Feed override

© Bosch Rexroth AG 2004

RNC-48121-001\_NOR\_N\_D0\_2004-03-01.fh11

**Bosch Rexroth AG**  
 Bgm.-Dr.-Nebel-Straße 2 • D-97816 Lohr am Main  
 Tel. +49 9352 40-0 • Fax +49 9352 40-4885

revised: BRC/NOR, Gensler  
 proved: BRC/NOR, Weißbeck  
 released: BRC/NOR, Breitenbach

Page 1 / 1  
 Type\_VAM\_10.FH9

Fig. 9-1: Type code VAM 10.1



## 9.2 Accessories

Ordering designation of the prefabricated cables	Mating connector of the unit	Rexroth cable	Design of the cable end
<p><b>IKB0033/000,0</b>                      PN: 291808                      PROFIBUS cable</p>	<p>INS0541/K01</p> 		<p>INS0541/K01</p> 
<p><b>IKB0034/000,0</b>                      PN: 291809</p>	<p>INS0541/K01</p> 		

Fig. 9-3: Cable accessories



## 10 List of Figures

- Fig. 1-1: Front view VAM 10.1 1-1
- Fig. 1-2: Front view VAM 40.1 1-2
- Fig. 3-1: Hazard classification (according to ANSI Z535) 3-1
- Fig. 4-1: General technical data 4-1
- Fig. 4-2: Electrical data 4-1
- Fig. 4-3: Connection method 4-1
- Fig. 4-4: Contact assignment of the key switch 4-2
- Fig. 4-5: Technical data of the key switch 4-2
- Fig. 4-6: Technical data for machine pushbutton and E-STOP 4-3
- Fig. 4-7: Ambient conditions 4-3
- Fig. 4-8: Used standards 4-4
- Fig. 5-1: Housing dimensions VAM 10.1, front, side and top view 5-1
- Fig. 5-2: Housing dimensions VAM 10.1, rear view 5-1
- Fig. 5-3: Housing dimensions VAM 40.1, front, side and top view 5-2
- Fig. 5-4: Housing dimensions VAM 40.1, rear view 5-2
- Fig. 5-5: Mounting dimensions VAM 10.1 5-4
- Fig. 5-6: Mounting dimensions VAM 40.1 5-4
- Fig. 6-1: Basic device 1
- Fig. 6-2: E-STOP and key switch 2
- Fig. 6-3: Keypads 2
- Fig. 6-4: Override rotary switch 3
- Fig. 6-5: Quick STOP module 4
- Abb. 7-1: View on the connector panel (VAM 40.1) 7-1
- Fig. 7-2: Pin assignment X10 7-2
- Fig. 7-3: Fuses 7-2
- Fig. 7-4: Field bus interface PROFIBUS DP according to EN 50170, Part 2 (DP) 7-3
- Fig. 7-5: Pin assignment of the PROFIBUS DP interface 7-3
- Fig. 7-6: Pin assignment of the PROFIBUS DP interface 7-3
- Fig. 7-7: Pin assignment X21, X22, X11 7-4
- Fig. 7-8: Characteristics of digital inputs 7-5
- Fig. 7-9: Characteristics of digital outputs 7-5
- Fig. 7-10: Pin assignment X81 7-6
- Fig. 7-11: Pin assignment X81 7-6
- Fig. 7-12: Characteristics of the handwheel interface 7-7
- Fig. 7-13: Pin assignment X81 7-7
- Fig. 8-1: BCD rotary switch S1 and S2 8-2
- Fig. 8-2: Status displays H1-H4 8-3
- Fig. 8-3: Status displays 8-4
- Fig. 8-4: Display of status "System stop" 8-5
- Fig. 8-5: Keypad TA 8-6
- Fig. 8-6: I/O assignment of module keypad 1 8-6

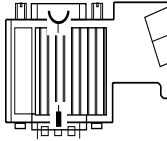
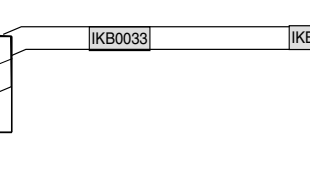
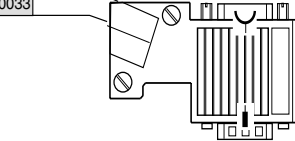
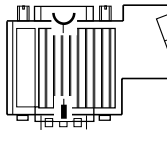
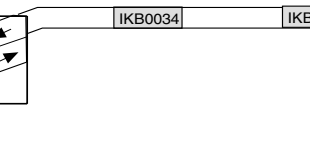
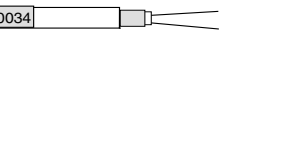
- Fig. 8-7: I/O assignment of module keypad 2 8-6
- Fig. 8-8: Override rotary switch - schematic 8-7
- Fig. 8-9: Gray code table 8-7
- Fig. 8-10: Input assignment of module Override VB 8-7
- Fig. 8-11: I/O assignment of module 16DI, 8DO 8-8
- Fig. 8-12: Input assignment for module "Manual Control Unit" 8-8
- Fig. 8-13: Input assignment for module "Handwheel" 8-8
- Fig. 8-14: VAM 10.1-PB-NA-TA-TA-VB-1608-NN 8-9
- Fig. 8-15: VAM 40.1-PB-NA-TA-TA-VB-1608-NN 8-9
- Fig. 8-16: Exemplary configuration with IndraLogic 8-10
- Fig. 9-1: Type code VAM 10.1 9-1
- Fig. 9-2: Type code VAM 40.1 9-2
- Fig. 9-3: Cable accessories 9-3

# 11 Service & Support

## 11.1 Helpdesk

Unser Kundendienst-Helpdesk im Hauptwerk Lohr am Main steht Ihnen mit Rat und Tat zur Seite. Sie erreichen uns

Our service helpdesk at our headquarters in Lohr am Main, Germany can assist you in all kinds of inquiries. Contact us

- telefonisch - by phone:  
über Service Call Entry Center  
- via Service Call Entry Center **+49 (0) 9352 40 50 60**  
Mo-Fr 07:00-18:00  
Mo-Fr 7:00 am - 6:00 pm
- per Fax - by fax: **+49 (0) 9352 40 49 41**
- per e-Mail - by e-mail: [service.svc@boschrexroth.de](mailto:service.svc@boschrexroth.de)

## 11.2 Service-Hotline

Außerhalb der Helpdesk-Zeiten ist der Service direkt ansprechbar unter

After helpdesk hours, contact our service department directly at

**+49 (0) 171 333 88 26**  
oder - or **+49 (0) 172 660 04 06**

## 11.3 Internet

Unter [www.boschrexroth.com](http://www.boschrexroth.com) finden Sie ergänzende Hinweise zu Service, Reparatur und Training sowie die **aktuellen** Adressen \*) unserer auf den folgenden Seiten aufgeführten Vertriebs- und Servicebüros.

- Verkaufsniederlassungen
- Niederlassungen mit Kundendienst

Außerhalb Deutschlands nehmen Sie bitte zuerst Kontakt mit unserem für Sie nächstgelegenen Ansprechpartner auf.

\*) Die Angaben in der vorliegenden Dokumentation können seit Drucklegung überholt sein.

At [www.boschrexroth.com](http://www.boschrexroth.com) you may find additional notes about service, repairs and training in the Internet, as well as the **actual** addresses \*) of our sales- and service facilities figuring on the following pages.

- sales agencies
- offices providing service

Please contact our sales / service office in your area first.

\*) Data in the present documentation may have become obsolete since printing.

## 11.4 Vor der Kontaktaufnahme... - Before contacting us...

Wir können Ihnen schnell und effizient helfen wenn Sie folgende Informationen bereithalten:

1. detaillierte Beschreibung der Störung und der Umstände.
2. Angaben auf dem Typenschild der betreffenden Produkte, insbesondere Typenschlüssel und Seriennummern.
3. Tel./Faxnummern und e-Mail-Adresse, unter denen Sie für Rückfragen zu erreichen sind.

For quick and efficient help, please have the following information ready:

1. Detailed description of the failure and circumstances.
2. Information on the type plate of the affected products, especially type codes and serial numbers.
3. Your phone/fax numbers and e-mail address, so we can contact you in case of questions.

## 11.5 Kundenbetreuungsstellen - Sales & Service Facilities

### Deutschland – Germany

**vom Ausland:**

(0) nach Landeskennziffer weglassen!

from abroad:

don't dial (0) after country code!

<p>Vertriebsgebiet Mitte Germany Centre</p> <p>Rexroth Indramat GmbH Bgm.-Dr.-Nebel-Str. 2 / Postf. 1357 97816 Lohr am Main / 97803 Lohr</p> <p><b>Kompetenz-Zentrum Europa</b></p> <p>Tel.: +49 (0)9352 40-0 Fax: +49 (0)9352 40-4885</p>	<p><b>SERVICE AUTOMATION</b></p> <p><b>CALL ENTRY CENTER</b> <b>Helpdesk</b> <b>MO – FR</b> von 07:00 - 18:00 Uhr from 7 am – 6 pm</p> <p>Tel. +49 (0) 9352 40 50 60 Fax +49 (0) 9352 40 49 41 <a href="mailto:service.svc@boschrexroth.de">service.svc@boschrexroth.de</a></p>	<p><b>SERVICE AUTOMATION</b></p> <p><b>HOTLINE 24 / 7 / 365</b></p> <p>außerhalb der Helpdesk-Zeit out of helpdesk hours</p> <p>Tel.: +49 (0)172 660 04 06 oder / or Tel.: +49 (0)171 333 88 26</p>	<p><b>SERVICE AUTOMATION</b></p> <p><b>ERSATZTEILE / SPARES</b> verlängerte Ansprechzeit - extended office time -</p> <ul style="list-style-type: none"> <li>◆ nur an Werktagen - only on working days -</li> <li>◆ von 07:00 - 18:00 Uhr - from 7 am - 6 pm -</li> </ul> <p>Tel. +49 (0) 9352 40 42 22</p>
<p>Vertriebsgebiet Süd Germany South</p> <p>Bosch Rexroth AG Landshuter Allee 8-10 80637 München</p> <p>Tel.: +49 (0)89 127 14-0 Fax: +49 (0)89 127 14-490</p>	<p>Vertriebsgebiet West Germany West</p> <p>Bosch Rexroth AG Regionalzentrum West Borsigstrasse 15 40880 Ratingen</p> <p>Tel.: +49 (0)2102 409-0 Fax: +49 (0)2102 409-406 +49 (0)2102 409-430</p>	<p>Gebiet Südwest Germany South-West</p> <p>Bosch Rexroth AG Service-Regionalzentrum Süd-West Siemensstr. 1 70736 Fellbach</p> <p>Tel.: +49 (0)711 51046-0 Fax: +49 (0)711 51046-248</p>	
<p>Vertriebsgebiet Nord Germany North</p> <p>Bosch Rexroth AG Walsroder Str. 93 30853 Langenhagen</p> <p>Tel.: +49 (0) 511 72 66 57-0 Service: +49 (0) 511 72 66 57-256 Fax: +49 (0) 511 72 66 57-93 Service: +49 (0) 511 72 66 57-783</p>	<p>Vertriebsgebiet Mitte Germany Centre</p> <p>Bosch Rexroth AG Regionalzentrum Mitte Waldecker Straße 13 64546 Mörfelden-Walldorf</p> <p>Tel.: +49 (0) 61 05 702-3 Fax: +49 (0) 61 05 702-444</p>	<p>Vertriebsgebiet Ost Germany East</p> <p>Bosch Rexroth AG Beckerstraße 31 09120 Chemnitz</p> <p>Tel.: +49 (0)371 35 55-0 Fax: +49 (0)371 35 55-333</p>	<p>Vertriebsgebiet Ost Germany East</p> <p>Bosch Rexroth AG Regionalzentrum Ost Walter-Köhn-Str. 4d 04356 Leipzig</p> <p>Tel.: +49 (0)341 25 61-0 Fax: +49 (0)341 25 61-111</p>

## Europa (West) - Europe (West)

**vom Ausland:** (0) nach Landeskennziffer weglassen, **Italien:** 0 nach Landeskennziffer mitwählen  
**from abroad:** don't dial (0) after country code, **Italy:** dial 0 after country code

<b>Austria - Österreich</b> Bosch Rexroth GmbH Electric Drives & Controls Stachegasse 13 1120 Wien Tel.: +43 (0)1 985 25 40 Fax: +43 (0)1 985 25 40-93	<b>Austria – Österreich</b> Bosch Rexroth GmbH Electric Drives & Controls Industriepark 18 4061 Pasching Tel.: +43 (0)7221 605-0 Fax: +43 (0)7221 605-21	<b>Belgium - Belgien</b> Bosch Rexroth NV/SA Henri Genessestraat 1 1070 Bruxelles Tel: +32 (0) 2 451 26 08 Fax: +32 (0) 2 451 27 90 <a href="mailto:info@boschrexroth.be">info@boschrexroth.be</a> <a href="mailto:service@boschrexroth.be">service@boschrexroth.be</a>	<b>Denmark - Dänemark</b> BEC A/S Zinkvej 6 8900 Randers Tel.: +45 (0)87 11 90 60 Fax: +45 (0)87 11 90 61
<b>Great Britain – Großbritannien</b> Bosch Rexroth Ltd. Electric Drives & Controls Broadway Lane, South Cerney Cirencester, Glos GL7 5UH Tel.: +44 (0)1285 863000 Fax: +44 (0)1285 863030 <a href="mailto:sales@boschrexroth.co.uk">sales@boschrexroth.co.uk</a> <a href="mailto:service@boschrexroth.co.uk">service@boschrexroth.co.uk</a>	<b>Finnland - Finnland</b> Bosch Rexroth Oy Electric Drives & Controls Ansatie 6 017 40 Vantaa Tel.: +358 (0)9 84 91-11 Fax: +358 (0)9 84 91-13 60	<b>France - Frankreich</b> Bosch Rexroth SAS Electric Drives & Controls Avenue de la Trentaine (BP. 74) 77503 Chelles Cedex Tel.: +33 (0)164 72-63 22 Fax: +33 (0)164 72-63 20 <b>Hotline: +33 (0)608 33 43 28</b>	<b>France - Frankreich</b> Bosch Rexroth SAS Electric Drives & Controls ZI de Thibaud, 20 bd. Thibaud (BP. 1751) 31084 Toulouse Tel.: +33 (0)5 61 43 61 87 Fax: +33 (0)5 61 43 94 12
<b>France – Frankreich</b> Bosch Rexroth SAS Electric Drives & Controls 91, Bd. Irène Joliot-Curie 69634 Vénissieux – Cedex Tel.: +33 (0)4 78 78 53 65 Fax: +33 (0)4 78 78 53 62	<b>Italy - Italien</b> Bosch Rexroth S.p.A. Via G. Di Vittorio, 1 20063 Cernusco S/N.MI <b>Hotline: +39 02 92 365 563</b> Tel.: +39 02 92 365 1 Service: +39 02 92 365 300 Fax: +39 02 92 365 500 Service: +39 02 92 365 516	<b>Italy - Italien</b> Bosch Rexroth S.p.A. Via Paolo Veronesi, 250 10148 Torino Tel.: +39 011 224 88 11 Fax: +39 011 224 88 30	<b>Italy - Italien</b> Bosch Rexroth S.p.A. Via Mascia, 1 80053 Castellamare di Stabia NA Tel.: +39 081 8 71 57 00 Fax: +39 081 8 71 68 85
<b>Italy - Italien</b> Bosch Rexroth S.p.A. Via del Progresso, 16 (Zona Ind.) 35020 Padova Tel.: +39 049 8 70 13 70 Fax: +39 049 8 70 13 77	<b>Italy - Italien</b> Bosch Rexroth S.p.A. Via Isonzo, 61 40033 Casalecchio di Reno (Bo) Tel.: +39 051 29 86 430 Fax: +39 051 29 86 490	<b>Netherlands - Niederlande/Holland</b> Bosch Rexroth Services B.V. Technical Services Kruisbroeksestraat 1 (P.O. Box 32) 5281 RV Boxtel Tel.: +31 (0) 411 65 19 51 Fax: +31 (0) 411 67 78 14 <b>Hotline: +31 (0) 411 65 19 51</b> <a href="mailto:services@boschrexroth.nl">services@boschrexroth.nl</a>	<b>Netherlands – Niederlande/Holland</b> Bosch Rexroth B.V. Kruisbroeksestraat 1 (P.O. Box 32) 5281 RV Boxtel Tel.: +31 (0) 411 65 16 40 Fax: +31 (0) 411 65 14 83 <a href="http://www.boschrexroth.nl">www.boschrexroth.nl</a>
<b>Norway - Norwegen</b> Bosch Rexroth AS Electric Drives & Controls Berghagan 1 or: Box 3007 1405 Ski-Langhus 1402 Ski Tel.: +47 (0) 64 86 41 00 Fax: +47 (0) 64 86 90 62 <b>Hotline: +47 (0)64 86 94 82</b> <a href="mailto:jul.ruud@rexroth.no">jul.ruud@rexroth.no</a>	<b>Spain – Spanien</b> Goimendi Automation Parque Empresarial Zuatzu C/ Francisco Grandmontagne no.2 20018 San Sebastian Tel.: +34 9 43 31 84 21 - service: +34 9 43 31 84 56 Fax: +34 9 43 31 84 27 - service: +34 9 43 31 84 60 <a href="mailto:sat.indramat@goimendi.es">sat.indramat@goimendi.es</a>	<b>Spain - Spanien</b> Bosch Rexroth S.A. Electric Drives & Controls Centro Industrial Santiga Obradors s/n 08130 Santa Perpetua de Mogoda Barcelona Tel.: +34 9 37 47 94 00 Fax: +34 9 37 47 94 01	<b>Spain - Spanien</b> Bosch Rexroth S.A. Electric Drives & Controls c/ Almazara, 9 28760 Tres Cantos (Madrid) Tel.: +34 91 806 24 79 Fax: +34 91 806 24 72 <a href="mailto:fernando.bariego@boschrexroth.es">fernando.bariego@boschrexroth.es</a>
<b>Sweden - Schweden</b> Bosch Rexroth AB Electric Drives & Controls - Varuvägen 7 (Service: Konsumentvägen 4, Älfsjö) 125 81 Stockholm Tel.: +46 (0)8 727 92 00 Fax: +46 (0)8 647 32 77	<b>Sweden - Schweden</b> Bosch Rexroth AB Electric Drives & Controls Ekvändan 7 254 67 Helsingborg Tel.: +46 (0) 42 38 88 -50 Fax: +46 (0) 42 38 88 -74	<b>Switzerland East - Schweiz Ost</b> Bosch Rexroth Schweiz AG Electric Drives & Controls Hemrietstrasse 2 8863 Buttikon Tel. +41 (0) 55 46 46 111 Fax +41 (0) 55 46 46 222	<b>Switzerland West - Schweiz West</b> Bosch Rexroth Suisse SA Av. Général Guisan 26 1800 Vevey 1 Tel.: +41 (0)21 632 84 20 Fax: +41 (0)21 632 84 21

## Europa (Ost) - Europe (East)

**vom Ausland:** (0) nach Landeskenziffer weglassen  
**from abroad:** don't dial (0) after country code

<p>Czech Republic - Tschechien</p> <p>Bosch -Rexroth, spol.s.r.o.  Hviezdoslavova 5  627 00 Brno  Tel.: +420 (0)5 48 126 358  Fax: +420 (0)5 48 126 112</p>	<p>Czech Republic - Tschechien</p> <p>DEL a.s.  Strojírenská 38  591 01 Zdar nad Sázavou  Tel.: +420 566 64 3144  Fax: +420 566 62 1657</p>	<p>Hungary - Ungarn</p> <p>Bosch Rexroth Kft.  Angol utca 34  1149 Budapest  Tel.: +36 (1) 422 3200  Fax: +36 (1) 422 3201</p>	<p>Poland – Polen</p> <p>Bosch Rexroth Sp.zo.o.  ul. Staszica 1  05-800 Pruszków  Tel.: +48 22 738 18 00  – service: +48 22 738 18 46  Fax: +48 22 758 87 35  – service: +48 22 738 18 42</p>
<p>Poland – Polen</p> <p>Bosch Rexroth Sp.zo.o.  Biuro Poznan  ul. Dabrowskiego 81/85  60-529 Poznan  Tel.: +48 061 847 64 62 /-63  Fax: +48 061 847 64 02</p>	<p>Romania - Rumänien</p> <p>East Electric S.R.L.  Bdul Basarabia no.250, sector 3  73429 Bucuresti  Tel./Fax: +40 (0)21 255 35 07  +40 (0)21 255 77 13  Fax: +40 (0)21 725 61 21  <a href="mailto:eastel@rdsnet.ro">eastel@rdsnet.ro</a></p>	<p>Romania - Rumänien</p> <p>Bosch Rexroth Sp.zo.o.  Str. Drobety nr. 4-10, app. 14  70258 Bucuresti, Sector 2  Tel.: +40 (0)1 210 48 25  +40 (0)1 210 29 50  Fax: +40 (0)1 210 29 52</p>	<p>Russia - Russland</p> <p>Bosch Rexroth OOO  Wjatskaja ul. 27/15  127015 Moskau  Tel.: +7-095-785 74 78  +7-095 785 74 79  Fax: +7 095 785 74 77  <a href="mailto:laura.kanina@boschrexroth.ru">laura.kanina@boschrexroth.ru</a></p>
<p>Russia Belarus - Weissrussland</p> <p>ELMIS  10, Internationalnaya  246640 Gomel, Belarus  Tel.: +375/ 232 53 42 70  +375/ 232 53 21 69  Fax: +375/ 232 53 37 69  <a href="mailto:elmis_ltd@yahoo.com">elmis_ltd@yahoo.com</a></p>	<p>Turkey - Türkei</p> <p>Bosch Rexroth Otomasyon  San &amp; Tic. A..S.  Fevzi Cakmak Cad No. 3  34630 Sefaköy Istanbul  Tel.: +90 212 413 34 00  Fax: +90 212 413 34 17  <a href="http://www.boschrexroth.com.tr">www.boschrexroth.com.tr</a></p>	<p>Turkey - Türkei</p> <p>Servo Kontrol Ltd. Sti.  Perpa Ticaret Merkezi B Blok  Kat: 11 No: 1609  80270 Okmeydani-Istanbul  Tel: +90 212 320 30 80  Fax: +90 212 320 30 81  <a href="mailto:remzi.sali@servokontrol.com">remzi.sali@servokontrol.com</a>  <a href="http://www.servokontrol.com">www.servokontrol.com</a></p>	<p>Slowenia - Slowenien</p> <p>DOMEL  Otoki 21  64 228 Zelezniki  Tel.: +386 5 5117 152  Fax: +386 5 5117 225  <a href="mailto:brane.ozebek@domel.si">brane.ozebek@domel.si</a></p>

## Africa, Asia, Australia – incl. Pacific Rim

<p>Australia - Australien</p> <p>AIMS - Australian Industrial Machinery Services Pty. Ltd. 28 Westside Drive Laverton North Vic 3026 Melbourne</p> <p>Tel.: +61 3 93 14 3321 Fax: +61 3 93 14 3329 <b>Hotlines: +61 3 93 14 3321 +61 4 19 369 195</b> <a href="mailto:enquires@aimservices.com.au">enquires@aimservices.com.au</a></p>	<p>Australia - Australien</p> <p>Bosch Rexroth Pty. Ltd. No. 7, Endeavour Way Braeside Victoria, 31 95 Melbourne</p> <p>Tel.: +61 3 95 80 39 33 Fax: +61 3 95 80 17 33 <a href="mailto:mel@rexroth.com.au">mel@rexroth.com.au</a></p>	<p>China</p> <p>Shanghai Bosch Rexroth Hydraulics &amp; Automation Ltd. Waigaoqiao, Free Trade Zone No.122, Fu Te Dong Yi Road Shanghai 200131 - P.R.China</p> <p>Tel.: +86 21 58 66 30 30 Fax: +86 21 58 66 55 23 <a href="mailto:richard.yang_sh@boschrexroth.com.cn">richard.yang_sh@boschrexroth.com.cn</a> <a href="mailto:qf.zhu_sh@boschrexroth.com.cn">qf.zhu_sh@boschrexroth.com.cn</a></p>	<p>China</p> <p>Shanghai Bosch Rexroth Hydraulics &amp; Automation Ltd. 4/f, Marine Tower No.1, Pudong Avenue Shanghai 200120 - P.R.China</p> <p>Tel.: +86 21 68 86 15 88 Fax: +86 21 58 40 65 77</p>
<p>China</p> <p>Bosch Rexroth China Ltd. 15/F China World Trade Center 1, Jianguomenwai Avenue Beijing 100004, P.R.China</p> <p>Tel.: +86 10 65 05 03 80 Fax: +86 10 65 05 03 79</p>	<p>China</p> <p>Bosch Rexroth China Ltd. Guangzhou Repres. Office Room 1014-1016, Metro Plaza, Tian He District, 183 Tian He Bei Rd Guangzhou 510075, P.R.China</p> <p>Tel.: +86 20 8755-0030 +86 20 8755-0011 Fax: +86 20 8755-2387</p>	<p>China</p> <p>Bosch Rexroth (China) Ltd. A-5F., 123 Lian Shan Street Sha He Kou District Dalian 116 023, P.R.China</p> <p>Tel.: +86 411 46 78 930 Fax: +86 411 46 78 932</p>	<p>China</p> <p>Melchers GmbH BRC-SE, Tightening &amp; Press-fit 13 Floor Est Ocean Centre No.588 Yanan Rd. East 65 Yanan Rd. West Shanghai 200001</p> <p>Tel.: +86 21 6352 8848 Fax: +86 21 6351 3138</p>
<p>Hongkong</p> <p>Bosch Rexroth (China) Ltd. 6<sup>th</sup> Floor, Yeung Yiu Chung No.6 Ind Bldg. 19 Cheung Shun Street Cheung Sha Wan, Kowloon, Hongkong</p> <p>Tel.: +852 22 62 51 00 Fax: +852 27 41 33 44 <a href="mailto:alexis.siu@boschrexroth.com.hk">alexis.siu@boschrexroth.com.hk</a></p>	<p>India - Indien</p> <p>Bosch Rexroth (India) Ltd. Electric Drives &amp; Controls Plot. No.96, Phase III Peenya Industrial Area Bangalore – 560058</p> <p>Tel.: +91 80 51 17 0-211...-218 Fax: +91 80 83 94 345 +91 80 83 97 374 <a href="mailto:mohanvelu.t@boschrexroth.co.in">mohanvelu.t@boschrexroth.co.in</a></p>	<p>India - Indien</p> <p>Bosch Rexroth (India) Ltd. Electric Drives &amp; Controls Advance House, II Floor Ark Industrial Compound Narol Naka, Makwana Road Andheri (East), Mumbai - 400 059</p> <p>Tel.: +91 22 28 56 32 90 +91 22 28 56 33 18 Fax: +91 22 28 56 32 93 <a href="mailto:singh.op@boschrexroth.co.in">singh.op@boschrexroth.co.in</a></p>	<p>India - Indien</p> <p>Bosch Rexroth (India) Ltd. S-10, Green Park Extension New Delhi – 110016</p> <p>Tel.: +91 11 26 56 65 25 +91 11 26 56 65 27 Fax: +91 11 26 56 68 87 <a href="mailto:koul.rp@boschrexroth.co.in">koul.rp@boschrexroth.co.in</a></p>
<p>Indonesia - Indonesien</p> <p>PT. Bosch Rexroth Building # 202, Cilandak Commercial Estate Jl. Cilandak KKO, Jakarta 12560</p> <p>Tel.: +62 21 7891169 (5 lines) Fax: +62 21 7891170 - 71 <a href="mailto:rudu.karimun@boschrexroth.co.id">rudu.karimun@boschrexroth.co.id</a></p>	<p>Japan</p> <p>Bosch Rexroth Automation Corp. Service Center Japan Yutakagaoka 1810, Meito-ku, NAGOYA 465-0035, Japan</p> <p>Tel.: +81 52 777 88 41 +81 52 777 88 53 +81 52 777 88 79 Fax: +81 52 777 89 01</p>	<p>Japan</p> <p>Bosch Rexroth Automation Corp. Electric Drives &amp; Controls 2F, I.R. Building Nakamachidai 4-26-44, Tsuzuki-ku YOKOHAMA 224-0041, Japan</p> <p>Tel.: +81 45 942 72 10 Fax: +81 45 942 03 41</p>	<p>Korea</p> <p>Bosch Rexroth-Korea Ltd. Electric Drives and Controls Bongwoo Bldg. 7FL, 31-7, 1Ga Jangchoong-dong, Jung-gu Seoul, 100-391</p> <p>Tel.: +82 234 061 813 Fax: +82 222 641 295</p>
<p>Korea</p> <p>Bosch Rexroth-Korea Ltd. 1515-14 Dadae-Dong, Saha-gu Electric Drives &amp; Controls Pusan Metropolitan City, 604-050</p> <p>Tel.: +82 51 26 00 741 Fax: +82 51 26 00 747 <a href="mailto:eunkyong.kim@boschrexroth.co.kr">eunkyong.kim@boschrexroth.co.kr</a></p>	<p>Malaysia</p> <p>Bosch Rexroth Sdn.Bhd. 11, Jalan U8/82, Seksyen U8 40150 Shah Alam Selangor, Malaysia</p> <p>Tel.: +60 3 78 44 80 00 Fax: +60 3 78 45 48 00 <a href="mailto:hockhwa@hotmail.com">hockhwa@hotmail.com</a> <a href="mailto:rexroth1@tm.net.my">rexroth1@tm.net.my</a></p>	<p>Singapore - Singapur</p> <p>Bosch Rexroth Pte Ltd 15D Tuas Road Singapore 638520</p> <p>Tel.: +65 68 61 87 33 Fax: +65 68 61 18 25 <a href="mailto:sanjay.nemade@boschrexroth.com.sg">sanjay.nemade@boschrexroth.com.sg</a></p>	<p>South Africa - Südafrika</p> <p>TECTRA Automation (Pty) Ltd. 71 Watt Street, Meadowdale Edenvale 1609</p> <p>Tel.: +27 11 971 94 00 Fax: +27 11 971 94 40 <b>Hotline: +27 82 903 29 23</b> <a href="mailto:georgv@tectra.co.za">georgv@tectra.co.za</a></p>
<p>Taiwan</p> <p>Bosch Rexroth Co., Ltd. Taichung Industrial Area No.19, 38 Road Taichung, Taiwan 407, R.O.C.</p> <p>Tel.: +886 - 4 -235 08 383 Fax: +886 - 4 -235 08 586 <a href="mailto:jim.lin@boschrexroth.com.tw">jim.lin@boschrexroth.com.tw</a> <a href="mailto:david.lai@boschrexroth.com.tw">david.lai@boschrexroth.com.tw</a></p>	<p>Taiwan</p> <p>Bosch Rexroth Co., Ltd. Tainan Branch No. 17, Alley 24, Lane 737 Chung Cheng N.Rd. Yung Kang Tainan Hsien, Taiwan, R.O.C.</p> <p>Tel.: +886 - 6 -253 6565 Fax: +886 - 6 -253 4754 <a href="mailto:charlie.chen@boschrexroth.com.tw">charlie.chen@boschrexroth.com.tw</a></p>	<p>Thailand</p> <p>NC Advance Technology Co. Ltd. 59/76 Moo 9 Ramintra road 34 Tharang, Bangkhen, Bangkok 10230</p> <p>Tel.: +66 2 943 70 62 +66 2 943 71 21 Fax: +66 2 509 23 62 Hotline +66 1 984 61 52 <a href="mailto:sonkawin@hotmail.com">sonkawin@hotmail.com</a></p>	

## Nordamerika – North America

<b>USA</b> <b>Headquarters - Hauptniederlassung</b>  Bosch Rexroth Corporation Electric Drives & Controls 5150 Prairie Stone Parkway Hoffman Estates, IL 60192-3707  Tel.: +1 847 6 45 36 00 Fax: +1 847 6 45 62 01 <a href="mailto:servicebrc@boschrexroth-us.com">servicebrc@boschrexroth-us.com</a> <a href="mailto:repairbrc@boschrexroth-us.com">repairbrc@boschrexroth-us.com</a>	<b>USA Central Region - Mitte</b>  Bosch Rexroth Corporation Electric Drives & Controls Central Region Technical Center 1701 Harmon Road Auburn Hills, MI 48326  Tel.: +1 248 3 93 33 30 Fax: +1 248 3 93 29 06	<b>USA Southeast Region - Südwest</b>  Bosch Rexroth Corporation Electric Drives & Controls Southeastern Technical Center 3625 Swiftwater Park Drive Suwanee, Georgia 30124  Tel.: +1 770 9 32 32 00 Fax: +1 770 9 32 19 03	<b>USA SERVICE-HOTLINE</b>  - 7 days x 24hrs -  <b>+1-800-REX-ROTH</b> <b>+1 800 739 7684</b>
<b>USA East Region – Ost</b>  Bosch Rexroth Corporation Electric Drives & Controls Charlotte Regional Sales Office 14001 South Lakes Drive Charlotte, North Carolina 28273  Tel.: +1 704 5 83 97 62 +1 704 5 83 14 86	<b>USA Northeast Region – Nordost</b>  Bosch Rexroth Corporation Electric Drives & Controls Northeastern Technical Center 99 Rainbow Road East Granby, Connecticut 06026  Tel.: +1 860 8 44 83 77 Fax: +1 860 8 44 85 95	<b>USA West Region – West</b>  Bosch Rexroth Corporation 7901 Stoneridge Drive, Suite 220 Pleasant Hill, California 94588  Tel.: +1 925 227 10 84 Fax: +1 925 227 10 81	
<b>Canada East - Kanada Ost</b>  Bosch Rexroth Canada Corporation Burlington Division 3426 Mainway Drive Burlington, Ontario Canada L7M 1A8  Tel.: +1 905 335 5511 Fax: +1 905 335 4184 <b>Hotline: +1 905 335 5511</b> <a href="mailto:michael.moro@boschrexroth.ca">michael.moro@boschrexroth.ca</a>	<b>Canada West - Kanada West</b>  Bosch Rexroth Canada Corporation 5345 Goring St. Burnaby, British Columbia Canada V7J 1R1  Tel.: +1 604 205 5777 Fax: +1 604 205 6944 <b>Hotline: +1 604 205 5777</b> <a href="mailto:david.gunby@boschrexroth.ca">david.gunby@boschrexroth.ca</a>	<b>Mexico</b>  Bosch Rexroth Mexico S.A. de C.V. Calle Neptuno 72 Unidad Ind. Vallejo 07700 Mexico, D.F.  Tel.: +52 55 57 54 17 11 Fax: +52 55 57 54 50 73 <a href="mailto:mariofelipe.hernandez@boschrexroth.com.mx">mariofelipe.hernandez@boschrexroth.com.mx</a>	<b>Mexico</b>  Bosch Rexroth S.A. de C.V. Calle Argentina No 3913 Fracc. las Torres 64930 Monterrey, N.L.  Tel.: +52 81 83 65 22 53 +52 81 83 65 89 11 +52 81 83 49 80 91 Fax: +52 81 83 65 52 80

## Südamerika – South America

<b>Argentina - Argentinien</b>  Bosch Rexroth S.A.I.C. "The Drive & Control Company" Rosario 2302 B1606DLD Carapachay Provincia de Buenos Aires  Tel.: +54 11 4756 01 40 +54 11 4756 02 40 +54 11 4756 03 40 +54 11 4756 04 40 Fax: +54 11 4756 01 36 +54 11 4721 91 53 <a href="mailto:victor.jabif@boschrexroth.com.ar">victor.jabif@boschrexroth.com.ar</a>	<b>Argentina - Argentinien</b>  NAKASE Servicio Tecnico CNC Calle 49, No. 5764/66 B1653AOX Villa Balester Provincia de Buenos Aires  Tel.: +54 11 4768 36 43 Fax: +54 11 4768 24 13 <b>Hotline: +54 11 155 307 6781</b> <a href="mailto:nakase@usa.net">nakase@usa.net</a> <a href="mailto:nakase@nakase.com">nakase@nakase.com</a> <a href="mailto:gerencia@nakase.com">gerencia@nakase.com</a> (Service)	<b>Brazil - Brasilien</b>  Bosch Rexroth Ltda. Av. Tégula, 888 Ponte Alta, Atibaia SP CEP 12942-440  Tel.: +55 11 4414 56 92 +55 11 4414 56 84 Fax sales: +55 11 4414 57 07 Fax serv.: +55 11 4414 56 86 <a href="mailto:alexandre.wittwer@rexroth.com.br">alexandre.wittwer@rexroth.com.br</a>	<b>Brazil - Brasilien</b>  Bosch Rexroth Ltda. R. Dr.Humberto Pinheiro Vieira, 100 Distrito Industrial [Caixa Postal 1273] 89220-390 Joinville - SC  Tel./Fax: +55 47 473 58 33 Mobil: +55 47 9974 6645 <a href="mailto:prochnow@zaz.com.br">prochnow@zaz.com.br</a>
<b>Columbia - Kolumbien</b>  Reflutec de Colombia Ltda. Calle 37 No. 22-31 Santafé de Bogotá, D.C. Colombia  Tel.: +57 1 368 82 67 +57 1 368 02 59 Fax: +57 1 268 97 37 <a href="mailto:reflutec@etb.net.co">reflutec@etb.net.co</a>			



Bosch Rexroth AG  
Electric Drives and Controls  
P.O. Box 13 57  
97803 Lohr, Germany  
Bgm.-Dr.-Nebel-Str. 2  
97816 Lohr, Germany  
Phone +49 (0)93 52-40-50 60  
Fax +49 (0)93 52-40-49 41  
service.svc@boschrexroth.de  
www.boschrexroth.com

