

# Rexroth IndraControl VAU 01.1Z UPS

R911319454  
Edition 01

## Project Planning Manual

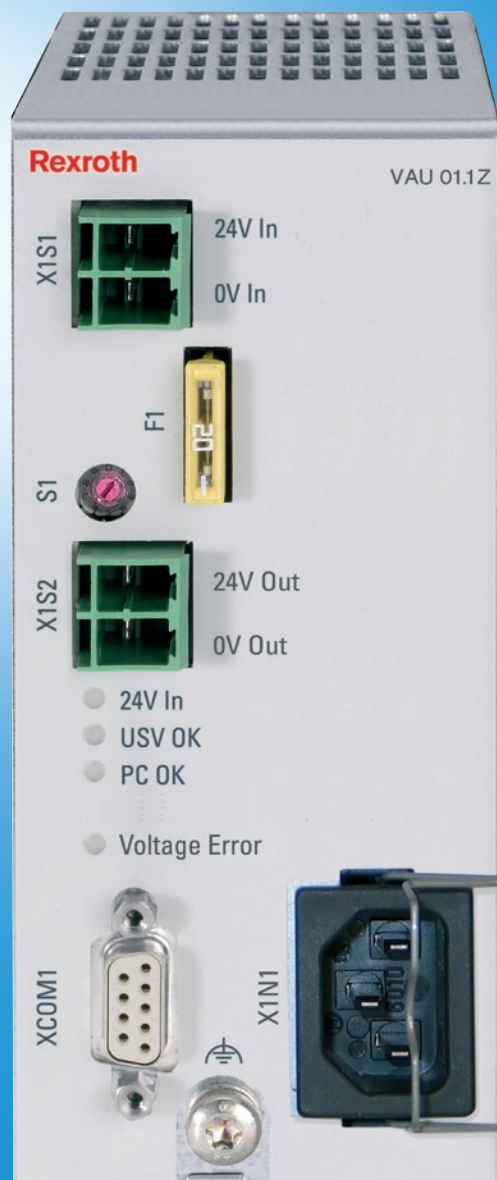

**Title** Rexroth IndraControl VAU 01.1Z  
UPS

**Type of Documentation** Project Planning Manual

**Document Typecode** DOK-SUPPL\*~VAU\*01.1Z\*\*~PR01-EN-P

**Internal File Reference** RS-6a915a0364e53ab60a6846a001bf9072-1-en-US-7

**Record of Revision**

Edition	Release Date	Notes
120-2100-B390-01/EN	04.2009	First edition

**Copyright** © Bosch Rexroth AG, 2009

Copying this document, giving it to others and the use or communication of the contents thereof without express authority, are forbidden. Offenders are liable for the payment of damages. All rights are reserved in the event of the grant of a patent or the registration of a utility model or design (DIN 34-1).

**Validity** The specified data is for product description purposes only and may not be deemed to be guaranteed unless expressly confirmed in the contract. All rights are reserved with respect to the content of this documentation and the availability of the product.

**Published by** Bosch Rexroth AG  
Bgm.-Dr.-Nebel-Str. 2 ■ 97816 Lohr am Main, Germany  
Phone +49 (0)93 52/ 40-0 ■ Fax +49 (0)93 52/ 40-48 85  
<http://www.boschrexroth.com/>  
Dept. DCC/EAY2 (MaKo/CaSp)

**Note** This document has been printed on chlorine-free bleached paper.

# Table of Contents

	Page
<b>1 System Presentation.....</b>	<b>3</b>
1.1 Short Description of the UPS.....	3
1.2 Software.....	4
1.3 Further Documentation.....	4
<b>2 Important Instructions on Use.....</b>	<b>5</b>
2.1 Appropriate Use.....	5
2.1.1 Introduction.....	5
2.1.2 Areas of Use and Application.....	5
2.2 Inappropriate Use.....	5
<b>3 Safety Instructions for Electric Drives and Controls .....</b>	<b>7</b>
3.1 Introduction.....	7
3.2 General Explanations.....	7
3.3 Hazards by Improper Use.....	7
3.4 General.....	8
3.5 Protection Against Contact with Electric Parts.....	9
3.6 Protection Against Electric Shock (PELV) by Protective Extra-Low Voltage.....	11
3.7 Protection Against Dangerous Movements.....	11
3.8 Protection Against Magnetic and Electromagnetic Fields During Operation and Mounting.....	13
3.9 Protection Against Contact with Hot Parts.....	13
3.10 Protection During Handling and Mounting.....	13
3.11 Battery Safety.....	14
3.12 Protection Against Pressurized Systems .....	14
<b>4 Technical Data.....</b>	<b>15</b>
4.1 Degree of Protection and Weight.....	15
4.2 Input and Output Voltage.....	15
4.2.1 +24 V Input Voltage.....	15
4.2.2 115/230 VAC Input Voltage.....	15
4.2.3 Output Voltage.....	15
4.3 Ambient Conditions.....	16
4.4 Standards.....	16
4.4.1 Used Standards.....	16
4.4.2 CE Marking.....	17
Declaration of Conformity .....	17
Note for the Machine Manufacturer.....	17
4.4.3 UL/CSA Certified.....	18
4.5 Compatibility Test.....	18
<b>5 Dimensions.....</b>	<b>19</b>
5.1 Housing Dimensions.....	19
5.2 Installation.....	19

Table of Contents

	Page
5.2.1	Installation Notes..... 19
5.2.2	Mounting..... 19
<b>6</b>	<b>Interfaces, Display and Operating Components..... 21</b>
6.1	Connector panel..... 21
6.1.1	General Information..... 21
6.1.2	Connection Overview..... 22
6.2	Voltage Connection..... 22
6.2.1	General Information..... 22
6.2.2	Wiring the Power Connection..... 23
6.2.3	UPS Wiring, Cable Lengths and Cable Cross-Sections..... 25
6.2.4	Example for a Voltage Supply of Several UPS Integrated in Control Cabinets by a High-performance Main UPS..... 26
6.3	Serial Interface XCOM1..... 26
6.3.1	General Information..... 26
6.3.2	Description of the COM Interface..... 27
6.4	Operating Display and Error Display..... 28
6.5	Fuses..... 29
6.6	Rotary Switch S1..... 29
6.6.1	General Information..... 29
6.6.2	Timing with Regard to the Position of Rotary Switch S1..... 30
<b>7</b>	<b>Maintenance and Installation..... 35</b>
7.1	General Information..... 35
<b>8</b>	<b>Environmental Protection and Disposal ..... 37</b>
8.1	Environmental Protection..... 37
8.2	Disposal..... 37
<b>9</b>	<b>Ordering Information..... 39</b>
9.1	Type Designation Code..... 39
9.2	VAU 01.1S Accessories..... 40
9.3	VAU 01.1U Accessories..... 40
<b>10</b>	<b>Service and Support..... 41</b>
	<b>Index..... 43</b>

# 1 System Presentation

## 1.1 Short Description of the UPS

The UPS (uninterruptible power supply) supplies the connected device for a certain period of time with voltage if the supply voltage (+24 VDC) fails.

This UPS is a DC UPS. That means that the input voltage as well as the output voltage of the UPS is +24 VDC. Instead of an accumulator, an AC power supply unit is installed that is supplied by a main UPS when the 24 V voltage supply fails. Thus, an output voltage of 24 V remains.

The UPS is able to provide the connected device with 24 V and 2.5 A for three minutes max. The communication between UPS and connected device occurs via a serial interface (XCOM1). The UPS consists of the following components:

- Enclosed metal housing.
- Power unit 115/230 VAC on +24 VDC integrated in the device. This power supply unit functions as an accumulator if the +24 V supply voltage for the UPS fails or is switched off.
- Display and operating components are arranged accessibly on the front panel.
- Integrated burst and surge protection for the connected device.

## System Presentation

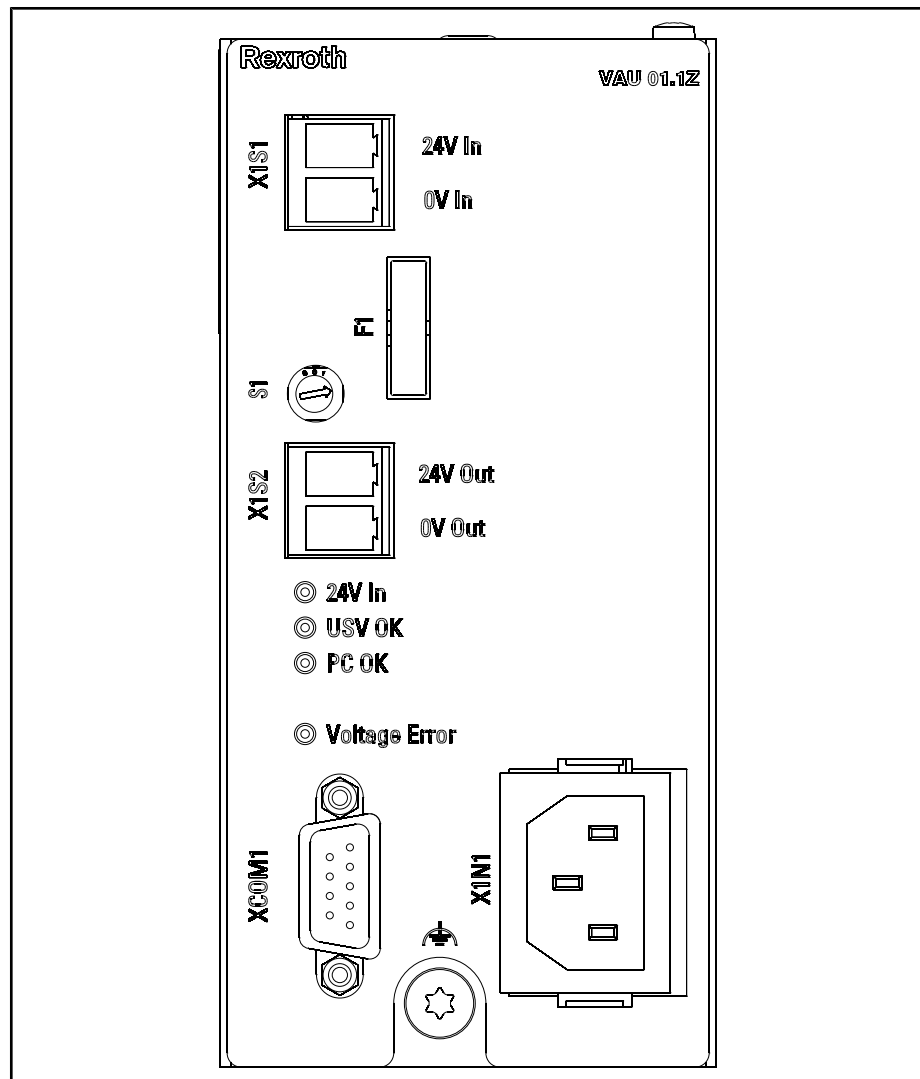

Fig.1-1: View of the UPS

## 1.2 Software

The communication between UPS and connected control cabinet PC occurs via a serial interface (XCOM1). Therefore, the UPS software has to be installed on the connected device. The installation is described in the documentation of the control cabinet PC (see [chapter 1.3 "Further Documentation" on page 4](#)).

## 1.3 Further Documentation

The UPS belongs to the accessories of the VPP 21 devices that are described in the the following documentations:

Rexroth Indra Control VPP 21.1	DOK-SUPPL*-VPP*21.1***-PR03-EN-P
Rexroth Indra Control VPP 21.2	DOK-SUPPL*-VPP*21.2***-PR01-EN-P

Fig.1-2: Further documentation for permitted devices on the VAU 01.1Z

## 2 Important Instructions on Use

### 2.1 Appropriate Use

#### 2.1.1 Introduction

Rexroth products represent state-of-the-art developments and manufacturing. They are tested prior to delivery to ensure operational safety and reliability.

Therefore the products may only be used for the intended purpose. If they are not used as intended, situations causing personal injury as well as material damage can occur.



Bosch Rexroth disclaims as manufacturer any warranty, liability or damages occurring due to inappropriate use of the products. Furthermore, Bosch Rexroth is not paying any compensation. The user is responsible for any risks resulting from inappropriate use of the products.

---

Before using Bosch Rexroth products, the following requirements must be met to ensure appropriate use of the products:

- Anyone handling one of the Rexroth products in any way has to read and understand the respective safety-related guidelines as well as the instructions on appropriate use.
- Hardware products have to remain in their original state, i.e. no modification regarding the design is allowed. Software products must not be decompiled and their source codes must not be modified.
- Damaged or faulty products must not be implemented or put into operation.
- It must be ensured that the products are installed as specified in the documentation.

#### 2.1.2 Areas of Use and Application



The may only be used with the accessories and add-on components specified in this documentation. Components not named expressly mentioned must neither be mounted nor connected. The same applies to cables and conduits.

An operation may only be carried out in the hardware component configurations and combinations specified and with the software and firmware specified in this documentation and in the corresponding functional description.

---

The UPS may only be operated under the assembly and installation conditions, in the position of application and under the ambient conditions (temperature, degree of protection, humidity, EMC, etc.) specified in this documentation.

### 2.2 Inappropriate Use

The application of the UPS that are not within the specified areas of application or under operating conditions deviating from the operating conditions and technical data specified in the documentation is considered as "inappropriate".

The UPS must not be used if

- it is exposed to operating conditions that do not fulfill the ambient conditions specified. For instance, operation under water, in case of extreme

## Important Instructions on Use

variations of temperature or in extreme maximum temperatures is not allowed.

- Bosch Rexroth has not explicitly released the intended applications. It is imperative that you also note the information given in the general notes on safety!

## 3 Safety Instructions for Electric Drives and Controls

### 3.1 Introduction

The following information must be read before the system is used for the first time to avoid physical injury and/or damage to property. This safety information must be observed at all times.

Do not attempt to install or commission the device without first reading all documentation provided with the product. Read and understand these safety instructions and all user documentation prior to working with the device. If you do not have the user documentation for the device, contact your responsible Bosch Rexroth sales representative. Ask for these documents to be sent immediately to the person or persons responsible for the safe operation of the device.

If the device is resold, rented and/or passed on to others in any other form, these safety instructions must be delivered with the device in the official language of the user's country.



**WARNING**

**Improper use of these devices, failure to follow the safety instructions in this document or tampering with the product, including disabling of safety devices, may result in material damage, bodily harm, electric shock or even death!**

### 3.2 General Explanations

The safety instructions describe the following degrees of hazard seriousness. The degree of hazard seriousness informs about the consequences resulting from non-compliance with the safety instructions:

Warning symbol with signal word	Hazard classification according to ANSI Z 535
 <b>DANGER</b>	Death or severe bodily harm will occur.
 <b>WARNING</b>	Death or severe bodily harm may occur.
 <b>CAUTION</b>	Bodily harm or material damage may occur.

Fig.3-1: Hazard classification (according to ANSI Z 535)

### 3.3 Hazards by Improper Use



**DANGER**

**High electric voltage and high working current! Risk of death or severe bodily injury by electric shock!**

## Safety Instructions for Electric Drives and Controls

**DANGER**

**Dangerous movements! Danger to life, severe bodily harm or material damage by unintentional motor movements!**

**WARNING**

**High electric voltage by incorrect connection! Risk of death or bodily injury by electric shock!**

**WARNING**

**Health hazard for persons with heart pacemakers, metal implants and hearing aids in proximity to electrical equipment!**

**CAUTION**

**Hot surfaces on device housing! Danger of injury! Danger of burns!**

**CAUTION**

**Risk of injury by improper handling! Risk of bodily injury by bruising, shearing, cutting, hitting or improper handling of pressurized lines!**

**CAUTION**

**Risk of injury by improper handling of batteries!**

## 3.4 General

- Bosch Rexroth AG is not liable for damages resulting from failure to observe the warnings provided in this documentation.
- Read the operating, maintenance and safety instructions in your language before commissioning the machine. If you find that you cannot completely understand the documentation for your product, please ask your supplier to clarify.
- Proper and correct transport, storage, assembly and installation, as well as care in operation and maintenance, are prerequisites for optimal and safe operation of this device.
- Only assign trained and qualified persons to work with electrical installations:
  - Only persons who are trained and qualified for the use and operation of the device may work on this device or within its proximity. The persons are qualified if they have sufficient knowledge of the assembly, installation and operation of the product, as well as an understanding of all warnings and precautionary measures noted in these instructions.
  - Furthermore, they must be trained, instructed and qualified to switch electrical circuits and devices on and off in accordance with technical safety regulations, to ground them and to mark them according to the

## Safety Instructions for Electric Drives and Controls

requirements of safe work practices. They must have adequate safety equipment and be trained in first aid.

- Only use spare parts and accessories approved by the manufacturer.
- Follow all safety regulations and requirements for the specific application as practiced in the country of use.
- The devices have been designed for installation in industrial machinery.
- The ambient conditions given in the product documentation must be observed.
- Only use safety-relevant applications that are clearly and explicitly approved in the Project Planning Manual. If this is not the case, they are excluded.

The following areas of use and application, for example, include safety features and applications: Construction cranes, elevators used for people and freight, devices and vehicles to transport people, medical applications, refinery plants, transport of hazardous goods, nuclear applications, applications in which electrical devices with vital functions can be electromagnetically disturbed, mining, food processing, control of protection equipment (also in machine).

- The information given in the documentation of the product with regard to the use of the delivered components contains only examples of applications and suggestions.

The machine and installation manufacturer must

- make sure that the delivered components are suited for his individual application and check the information given in this documentation with regard to the use of the components,
- make sure that his application complies with the applicable safety regulations and standards and carry out the required measures, modifications and complements.

Commissioning of the delivered components is only permitted once it is sure that the machine or installation in which they are installed complies with the national regulations, safety specifications and standards of the application.

- Operation is only permitted if the national EMC regulations for the application are met.
- The instructions for installation in accordance with EMC requirements can be found in the documentation "EMV in Drive and Control Systems".

The machine or installation manufacturer is responsible for compliance with the limiting values as prescribed in the national regulations.

- Technical data, connection and installation conditions are specified in the product documentation and must be followed at all times.

## 3.5 Protection Against Contact with Electric Parts



This section only concerns devices and drive components with voltages of more than 50 Volt.

---

Contact with parts conducting voltages above 50 volts can cause personal danger and electric shock. When operating electrical equipment, it is unavoidable that some parts of the units conduct dangerous voltage.

## Safety Instructions for Electric Drives and Controls

**High electrical voltage! Danger to life, electric shock and severe bodily injury!**

- Only those trained and qualified to work with or on electrical equipment are permitted to operate, maintain and repair this equipment.
- Follow general construction and safety regulations when working on electrical power installations.
- Before switching on the device, the equipment grounding conductor must have been permanently connected to all electrical equipment in accordance with the connection diagram.
- Do not operate electrical equipment at any time, even for brief measurements or tests, if the equipment grounding conductor is not permanently connected to the mounting points of the components provided for this purpose.
- Before working with electrical parts with voltage potentials higher than 50 V, the device must be disconnected from the mains voltage or power supply unit. Provide a safeguard to prevent reconnection.
- For electrical drive and filter components, observe the following:  
Wait 30 minutes after switching off power to allow capacitors to discharge before beginning to work. Measure the voltage in the capacitors before beginning work to preclude the risk of danger if the device is touched.
- Never touch the electrical connection points of a component while power is turned on.
- Install the covers and guards provided with the equipment properly before switching the device on. Before switching the equipment on, cover and safeguard live parts safely to prevent contact with those parts.
- A residual-current-operated circuit-breaker or r.c.d. cannot be used for electric drives! Indirect contact must be prevented by other means, for example, by an overcurrent protective device according to the relevant standards.
- Secure built-in devices from direct touching of electrical parts by providing an external housing, for example a control cabinet.

European countries: in accordance with EN 50178/ 1998, Section 5.3.2.3.

USA: See National Electric Code (NEC), National Electric Manufacturers Association (NEMA) and any regional building codes. The user must comply with all the above points at all times.

For electrical drive and filter components, observe the following:

**High housing voltage and high leakage current! Risk of death or bodily injury by electric shock!**

- Before switching on, the housings of all electrical equipment and motors must be connected or grounded with the equipment grounding conductor to the grounding points. This is also applicable before short tests.
- The equipment grounding conductor of the electrical equipment and the devices must be non-detachably and permanently connected to the power supply unit at all times. The leakage current is greater than 3.5 mA.
- Over the total length, use copper wire of a cross section of a minimum of 10 mm<sup>2</sup> for this equipment grounding connection!
- Before commissioning, also in trial runs, always attach the equipment grounding conductor or connect to the ground wire. Otherwise, high voltages may occur at the housing causing electric shock.

## 3.6 Protection Against Electric Shock (PELV) by Protective Extra-Low Voltage

All connections and terminals on Rexroth products with voltages of 5 to 50 volt are protective extra low voltages, made to protect against contact in accordance with the following standards:



**WARNING**

**High electric voltage by incorrect connection! Risk of death or bodily injury by electric shock!**

- Only devices, electrical components and lines with a Protective Extra Low Voltage (PELV) may be connected to any connections or terminals with voltages of 0 to 50 volt.
  - Only connect voltages and circuits that have safe isolation from dangerous voltages. Safe isolation can be achieved, for example, by isolating transformers, safe opto-electronic couplers or mains-free battery operation.
- 

## 3.7 Protection Against Dangerous Movements

Dangerous movements can be caused by faulty control of connected motors. Some common examples are:

- improper or wrong wiring of cable connections
- incorrect operation of the equipment components
- wrong input of parameters before operation
- malfunction of sensors, encoders and monitoring devices
- defective components
- software or firmware errors

These errors can occur immediately after equipment is switched on or even after an unspecified time of trouble-free operation.

The monitoring in the drive components will normally be sufficient to avoid faulty operation in the connected drives. Where personnel safety is concerned, particularly where there is a risk of physical injury and/or damage to property, this fact should not be relied on exclusively. Until the integrated monitoring functions become effective, it must be assumed in any case that faulty drive movements will occur. The extent of faulty drive movements depends upon the type of control and the state of operation.



**Dangerous movements! Danger to life, risk of injury, severe bodily harm or material damage!**

**To avoid accidents, bodily harm and/or material damage:**

- For the above reasons, ensure personal safety by means of qualified and tested higher-level monitoring devices or measures integrated in the installation.

They have to be provided for by the user according to the specific conditions within the installation and a hazard and fault analysis. The safety regulations applicable for the installation have to be taken into consideration. Unintended machine motion or other malfunction is possible if safety devices are disabled, bypassed or not activated.

- Keep free and clear of the machine's range of motion and moving parts. Possible measures to prevent people from accidentally entering the machine's range of motion:
  - use safety fences
  - use safety guards
  - use protective coverings
  - install light curtains or light barriers
- Fences and coverings must be strong enough to resist maximum possible momentum.
- Mount the emergency stop switch in the immediate reach of the operator. Verify that the emergency stop works before commissioning. Do not operate the device if the emergency stop switch is not working.
- Isolate the drive power connection by means of an emergency stop circuit or use a safety related starting lockout to prevent unintentional start.
- Make sure that the drives are brought to a safe standstill before accessing or entering the danger zone.
- Additionally secure vertical axes against falling or dropping after switching off the motor power by, for example:
  - mechanically securing the vertical axes,
  - adding an external braking/arrester/clamping mechanism or
  - ensuring sufficient equilibration of the vertical axes.

The standard equipment motor brake or an external brake controlled by the drive controller are not sufficient to guarantee personal safety!

- Disconnect electrical power to the equipment using a master switch and secure the switch against reconnection for:
  - maintenance and repair work
  - cleaning of equipment
  - long periods of discontinued equipment use
- Prevent the operation of high-frequency, remote control and radio equipment near electronics circuits and supply leads. If the use of such devices cannot be avoided, verify the system and the installation for possible malfunctions in all possible positions of normal use before initial commissioning. If necessary, perform a special electromagnetic compatibility (EMC) test on the installation.

### 3.8 Protection Against Magnetic and Electromagnetic Fields During Operation and Mounting

Magnetic and electromagnetic fields generated by current-carrying conductors and permanent magnets in motors represent a serious personal danger to those with heart pacemakers, metal implants and hearing aids.



WARNING

#### Health hazard for persons with heart pacemakers, metal implants and hearing aids in proximity to electrical equipment!

- Persons with heart pacemakers and metal implants are not permitted to enter following areas:
  - Areas in which electrical equipment and parts are mounted, being operated or commissioned.
  - Areas in which motor parts with permanent magnets are stored, repaired or assembled.
- If it is necessary for somebody with a pacemaker to enter such an area, a doctor must be consulted prior to doing so. The noise immunity of present or future implanted heart pacemakers differs greatly so that no general rules can be given.
- Those with metal implants or metal pieces, as well as with hearing aids, must consult a doctor before they enter the areas described above. Otherwise health hazards may occur.

### 3.9 Protection Against Contact with Hot Parts



CAUTION

#### Hot surfaces on device housing! Danger of injury! Danger of burns!

- Do not touch the surface of housings near sources of heat! Danger of burns!
- Before touching first allow devices to cool for ten minutes after switching off.
- Touching hot equipment parts such as device housings in which heatsinks and resistors are located can lead to burns!

### 3.10 Protection During Handling and Mounting

In unfavorable conditions, handling and mounting certain parts and components in an improper way can cause injuries.



CAUTION

#### Risk of injury by improper handling! Bodily injury by bruising, shearing, cutting, hitting!

- Observe the general construction and safety regulations on handling and mounting.
- Use suitable devices for mounting and transport.
- Avoid jamming and bruising by appropriate measures.
- Always use suitable tools. Use special tools if specified.
- Use lifting equipment and tools in the correct manner.
- If necessary, use suitable protective equipment (for example safety goggles, safety shoes, safety gloves).
- Do not stand under hanging loads.
- Immediately clean up any spilled liquids because of the danger of skidding.

## 3.11 Battery Safety

Batteries consist of active chemicals enclosed in a solid housing. Therefore, improper handling can cause injury or material damage.



### Risk of injury by improper handling!

- Do not attempt to reactivate low batteries by heating or other methods (risk of explosion and cauterization).
- Do not recharge the batteries as this may cause leakage or explosion.
- Do not throw batteries into open flames.
- Do not dismantle batteries.
- Do not damage electrical components installed in the equipment.



Environmental protection and disposal! The batteries contained in the product are considered dangerous goods during land, air, and sea transport (risk of explosion) in the sense of the legal regulations. Dispose of used batteries separate from other waste. Observe the local regulations in the country of assembly.

## 3.12 Protection Against Pressurized Systems

Certain motors and drive controllers, corresponding to the information in the respective Project Planning Manual, must be provided with pressurized media, such as compressed air, hydraulic oil, cooling fluid and cooling lubricant supplied by external systems. Incorrect handling of the supply and connections of pressurized systems can lead to injuries or accidents. Improper handling of the connected supply systems, supply lines or connections can cause injuries or material damage.



### Risk of injury by improper handling of pressurized lines!

- Do not attempt to disconnect, open or cut pressurized lines (risk of explosion).
- Observe the respective manufacturer's operating instructions.
- Before dismounting lines, relieve pressure and empty medium.
- Use suitable protective equipment (for example safety goggles, safety shoes, safety gloves).
- Immediately clean up any spilled liquids from the floor.



Environmental protection and disposal! The agents used to operate the product might not be economically friendly. Dispose of ecologically harmful agents separately from other waste. Observe the local regulations in the country of assembly.

## 4 Technical Data

### 4.1 Degree of Protection and Weight

Degree of protection	IP 20
Weight	1 kg

Fig.4-1: Degree of protection and weight

### 4.2 Input and Output Voltage

#### 4.2.1 +24 V Input Voltage

Nominal input voltage	24 VDC
Input voltage range	24 VDC +20 %, -15 %
Emitted interference and surge immunity	U <sub>max</sub> = 35 V (for t < 100 ms)
Power consumption at U <sub>N</sub>	2.5 A max.
Input fuse	None
Voltage rise of the supply voltage when switching on	Max. 500 ms (0 V to U <sub>N</sub> )
Voltage drop of the supply voltage when switching off	Max. 500 ms (U <sub>N</sub> to 0V)
Switch-on threshold	15.5 V ±5 %
Switch-off threshold	20.2 V ±5 %
Maximum power consumption	60 W <sup>①</sup>

① The UPS requires a maximum of 60 W (24 V, 2.5 A) from the 24 VDC supply.

Fig.4-2: +24V input voltage

#### 4.2.2 115/230 VAC Input Voltage

Nominal input voltage	115/230 VAC
Input voltage range	85 – 264 VAC
Input frequency	47 – 63 Hz
Power consumption at U <sub>N</sub>	115 VAC = 1.00 A typ. 230 VAC = 0.60 A typ.
Recommended protection	5 A

Fig.4-3: 115/230 VAC input voltage

#### 4.2.3 Output Voltage

Nominal output voltage	24 VDC
Output voltage range	24 VDC +20 %, -15 %
Current output at U <sub>N</sub>	2.5 A max.
Switching time	< 1 ms

Technical Data

Bridging time	Maximum 3 minutes
Maximum output power in the buffer mode	60 W

Fig.4-4: Output voltage

### 4.3 Ambient Conditions

	In operation	Storage / Transport
Surrounding air temperature	+5 to +45 °C	-20 °C to +60 °C
Maximum temperature gradient	Temperature change up to 3°C per minute	Temperature change up to 3°C per minute
Relative humidity	Climatic class 3K3 according to EN 60721, condensation not permissible. 80 % humidity max. for 25 °C	Climatic class 3K3 according to EN 60721, condensation not permissible. 80 % humidity max. for 25 °C
Air pressure	Up to 2,000 m above MSL according to DIN 60204	Up to 3000 m above MSL according to DIN 60204
Mechanical strength	Maximum vibration Frequency range: 10 to 150 Hz Excursion: 0.075 mm for 10 to 57 Hz Acceleration: 1 g for 57 to 150 Hz Test duration for each axis: 10 frequency cycles Frequency sweep rate: 1 octave/min According to EN 60068-2-6, test Fc	Maximum shock: 15 g according to EN 60068-2-27, no disturbance of the function
Degree of pollution	2	2

Fig.4-5: Ambient Conditions

### 4.4 Standards

#### 4.4.1 Used Standards

The system components of the VAU 01.1Z correspond to the following standards:

Standard	Meaning
EN 60 61000-6-4	Generic standard, emitted interference (industrial environment)
EN 60 61000-6-2	Generic standard, noise immunity (industrial environment)
EN 60664-1	Overvoltage category II
EN 60950	Clearances and creepage distances office (environment) and power units

Standard	Meaning
EN 60 529	Degrees of protection (including housings and installation compartments)
EN 60 068-2-6	Vibration test
EN 60068-2-27	Shock test
EN 60721-3-3	Classification of ambient conditions
EN 60721-3-2	Classification of ambient conditions
EN 60721-3-1	Classification of ambient conditions
UL 508	Industrial Control Equipment

Fig. 4-6: Used standards

## 4.4.2 CE Marking Declaration of Conformity



The electronic products described in the project planning manual comply with the requirements and goals of the following EC guideline and with the agreed European standards:

EMC guideline 2004/108/EC

The electronic products described in the project planning manual comply with the requirements on the operation within the industrial environment:

Standard	Title	Edition
DIN EN 61000-6-4 (VDE 0839-6-4)	Electromagnetic compatibility (EMC) Volume: 6-4: Generic standards - Immunity for industrial environments (IEC 61000-6-4:2006)	September 2007
DIN EN 61000-6-2 (VDE 0839-6-2)	Electromagnetic compatibility (EMC) Volume: 6-2: Generic standards - emitted interference for industrial environments (IEC 61000-6-2:2005)	March 2006

Fig. 4-7: Electromagnetic compatibility (EMC) standards

### Note for the Machine Manufacturer

The electronic products described in this project planning manual do not fall under the machines listed in the EC guidelines. Therefore, explanations are not required for the 89/392/EMC guideline and do not exist.

89/392/EMC, the EC guideline for machines, specifies the requirements on a machine. In this guideline, a machine is defined as a combination of the components or mechanisms combined with each other. The described products belong to the electrical equipment of a machine. Therefore, they are to be included in the declaration of conformity of the machine manufacturer.

The standard EN 60204-1 (safety of machinery, general requirements on the electrical equipment of the machines) can be used for the electrical equipment of the machines.



The CE marking is only valid for the device in its delivery status (ex works). After modifying the device, e.g. after plugging additional extension cards, CE compliance must be checked.

Technical Data

### 4.4.3 UL/CSA Certified



The devices of the IndraControl VAU 01.1Z family are certificated according to

- **UL508** (Industrial Control Equipment) and
- **C22.2 no. 142-M1987** (CSA)

UL file no. E210730

But there can be combination or extension stages with limited or missing certification. Thus, the registration is to be verified according to the UL marking on the device.



The UL/CSA marking is only valid for the device in its delivery status (ex works). After modifying the device, e.g. after plugging additional extension cards, UL compliance must be checked.

### 4.5 Compatibility Test

All Rexroth controls and drives are developed and tested according to the latest state-of-the-art of technology.

As it is impossible to follow the continuing development of all materials (e. g. lubricants in machine tools) which may interact with our controls and drives, it cannot be completely ruled out that any reactions with the materials used by Bosch Rexroth might occur.

For this reason, before using the respective material a compatibility test has to be carried out for new lubricants, cleaning agents etc. and our housings / our housing materials.

## 5 Dimensions

### 5.1 Housing Dimensions

The UPS has the following dimensions:

Width	70 mm
Height	145 mm
Depth (without plug)	133 mm

*Fig.5-1: Dimensions*

### 5.2 Installation

#### 5.2.1 Installation Notes

- The UPS is provided for top-hat rail mounting.

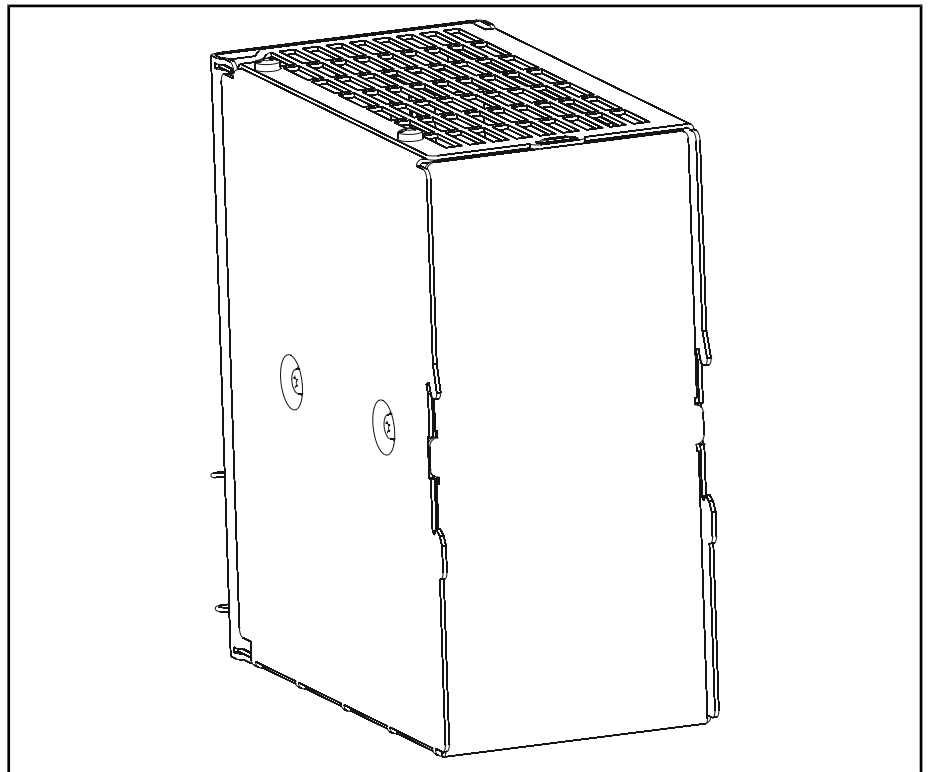

*Fig.5-2: Top-hat rail holders*

- Avoid positions of installation that are exposed to direct sunlight.
- Provide a sufficient minimum clearance of 50 mm to the bottom side and 80 mm to the top side.
- Lay all connecting cables in loops. Provide the cables with strain reliefs.
- Keep as much distance as possible to noise sources, when installing the UPS.

#### 5.2.2 Mounting

Only top-hat rails made of TH35-7.5 and TH35-15 steel according to EN 60715 are permitted.

## Dimensions

Determine the distance of the mounting holes according to EN 60715; appendix B.

On both sides of the UPS end clamps have to be mounted on the top-hat rail to prevent lateral moving of the UPS during vibration.

Unfixed cables are not permitted. An appropriate fixing (e. g. installation in a cable channel) and a strain relief of the cables is required.

## 6 Interfaces, Display and Operating Components

### 6.1 Connector panel

#### 6.1.1 General Information

The terminals for the voltage connection, the voltage output and the serial interface as well as the display and operating components are arranged on the connector panel.

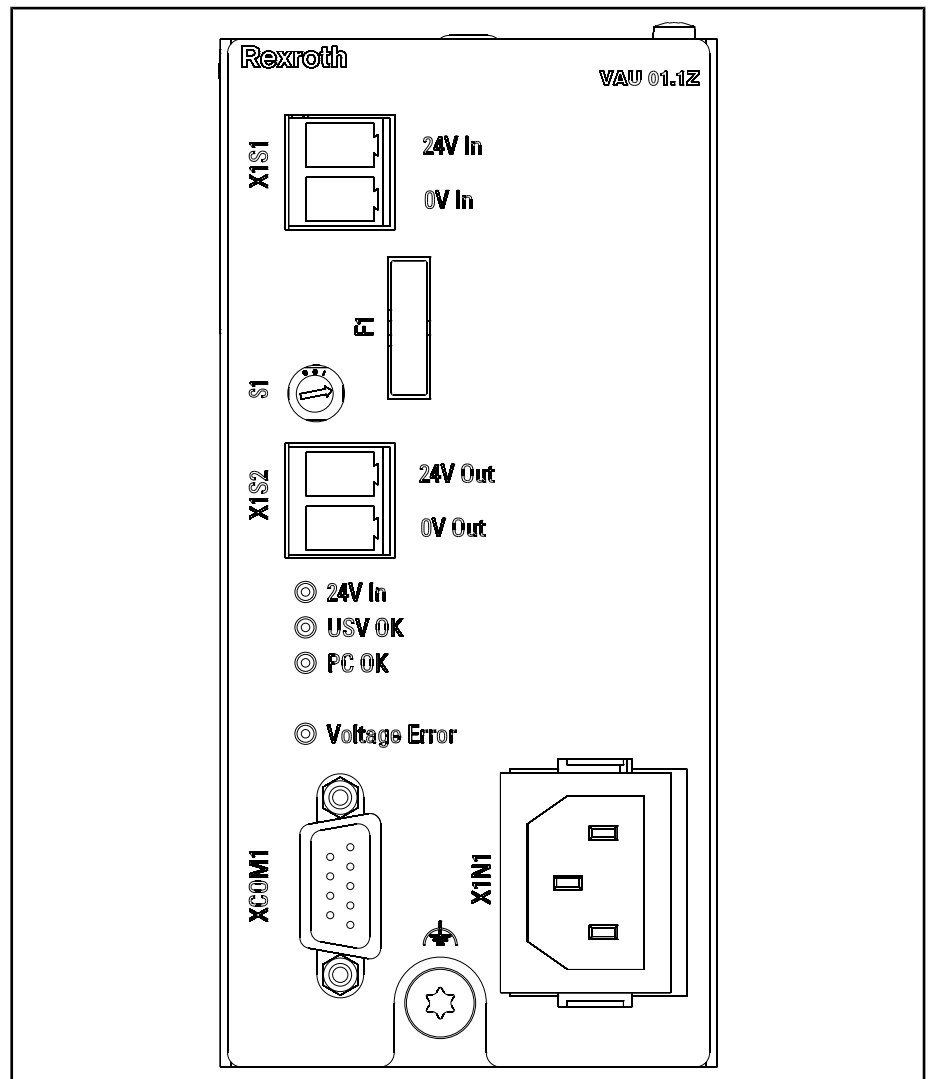

Fig.6-1: Connector panel

Interfaces, Display and Operating Components

## 6.1.2 Connection Overview

Designation at the housing	Connection type	Connector type (integrated)	Mating connector or cable (from outside)
X1S1	24 VDC power supply	Phoenix connector terminal, PC4/2-G-7,62, 2-pin	Phoenix female connector terminal, PC4/2-St-/7.62, 2-pin
X1S2	24 VDC output voltage	Phoenix connector terminal, PC4/2-G-7,62, 2-pin	Phoenix female connector terminal, PC4/2-St-/7.62, 2-pin
XCOM1	Serial interface RS232 (special assignment, see chapter 6.3 "Serial Interface XCOM1" on page 26)	D-Sub female connector, 9-pin	D-Sub male connector, 9-pin
X1N1	115/230 VAC power supply	IEC AC connector	Power line, minimum $3 \times 0.75 \text{ mm}^2$

Fig.6-2: Interfaces



All the mating connectors, apart from the feeder, are included in the scope of delivery.

## 6.2 Voltage Connection

### 6.2.1 General Information

The supply voltage of 24 V is connected to the X1S1 interface, the mains voltage is connected to the X1N1 interface. The output voltage of 24 V is provided at the X1S2 interface.

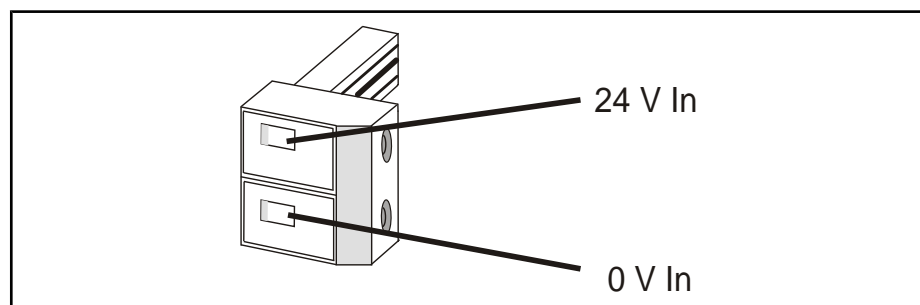

Fig.6-3: Connection of the 24 V voltage supply at the connector



Use only copper wire for connecting these terminals. Tighten the screws of the screw terminal blocks with a tightening torque of 5.5 lb in (0.6 Nm).

### 6.2.2 Wiring the Power Connection

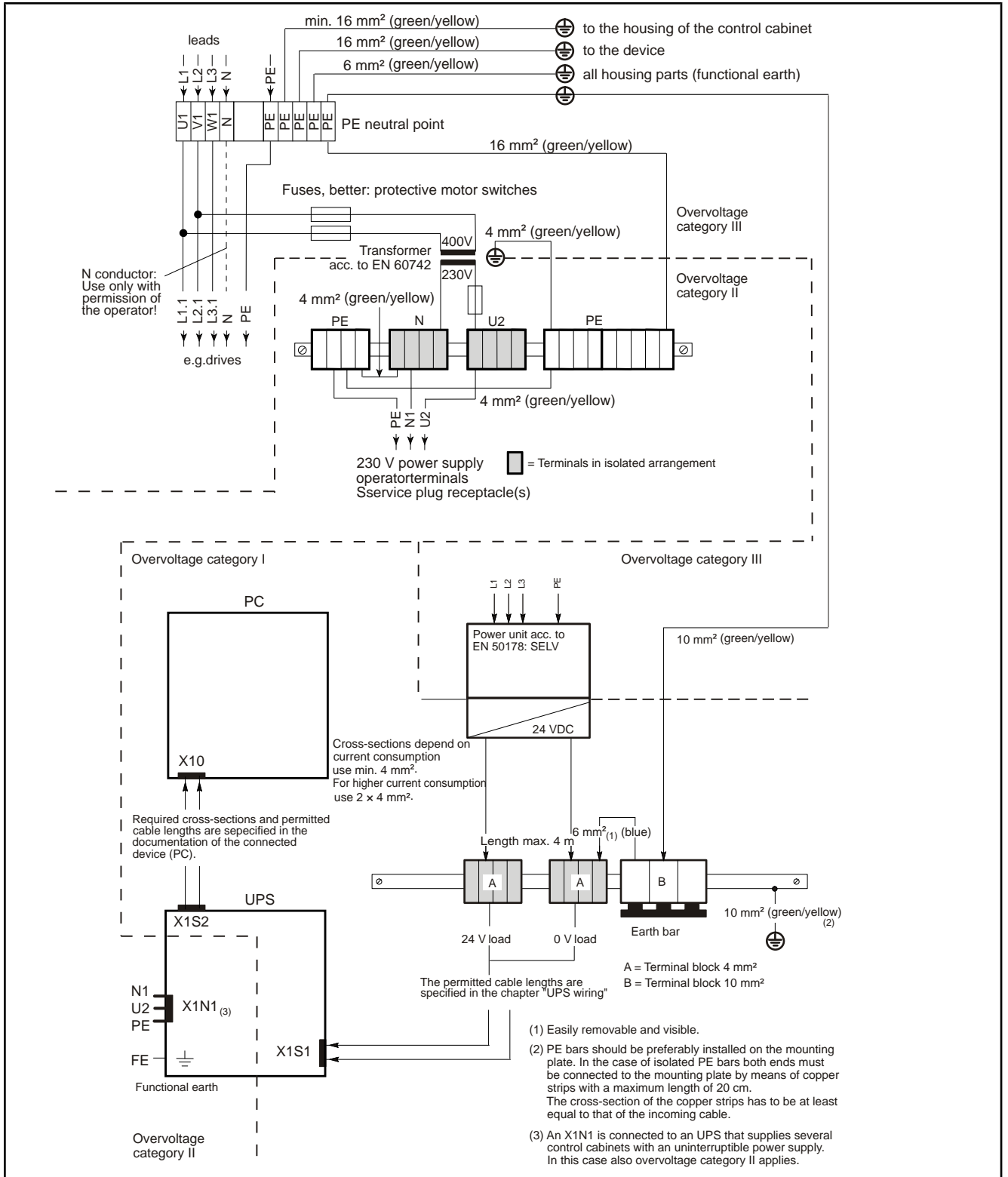

Fig.6-4: Wiring the power connection: 24 VDC to the UPS and 115/230 VAC to the UPS when 400 V supply voltage of the 24 V power supply unit are applied

Interfaces, Display and Operating Components

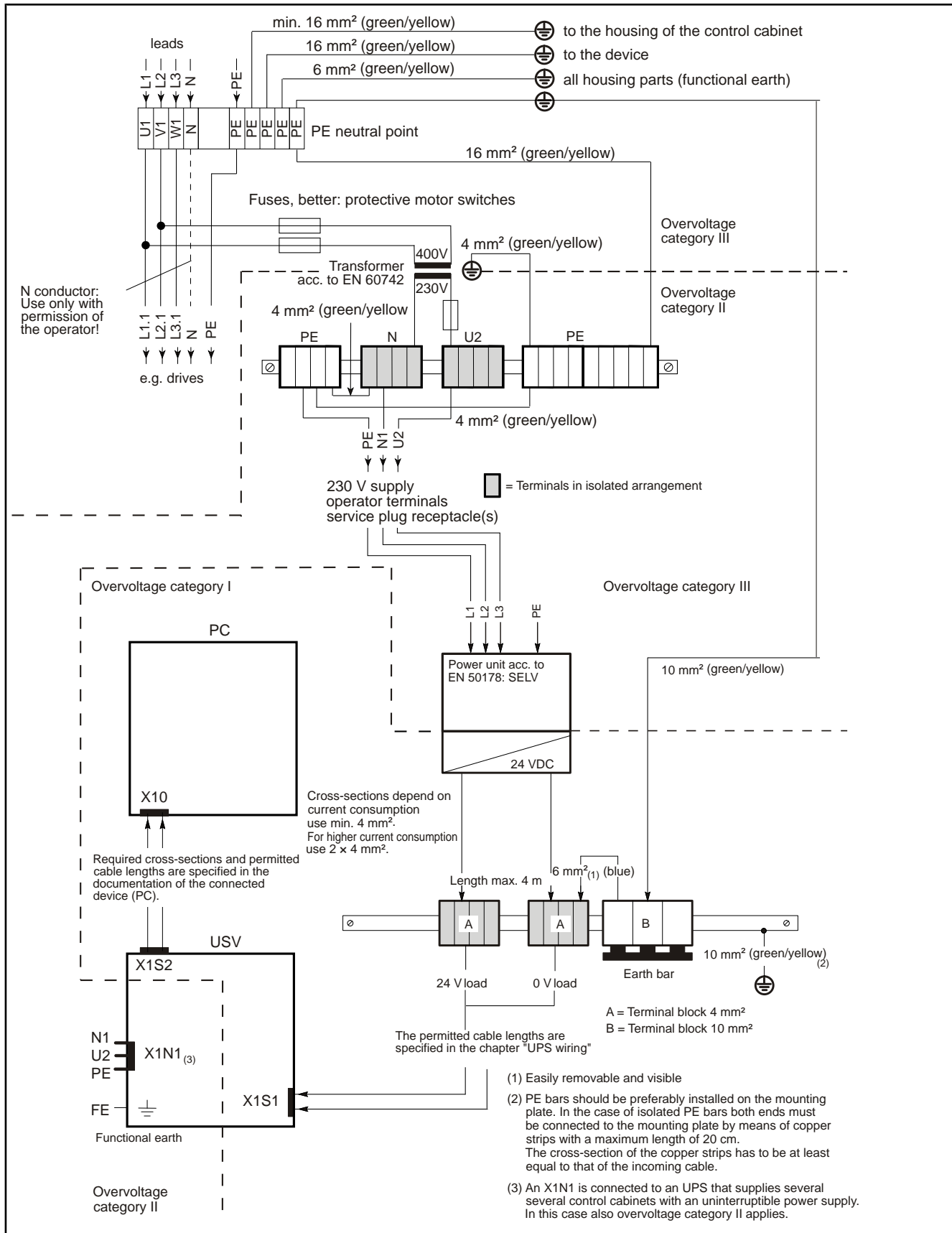

Fig.6-5: Wiring the power connection: 24 VDC to the UPS and 115/230 VAC to the UPS when 230 V supply voltage of the 24 V power supply unit are applied

### 6.2.3 UPS Wiring, Cable Lengths and Cable Cross-Sections

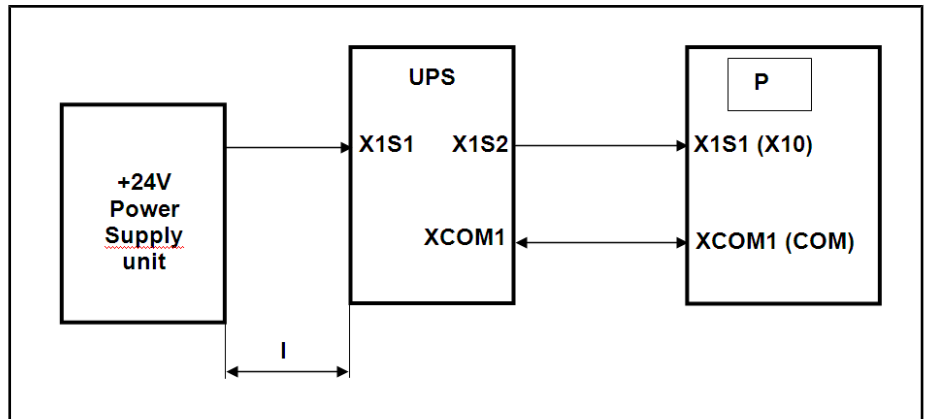

Fig. 6-6: Wiring of the UPS

Cable length l	Cable cross-sections in mm <sup>2</sup> (AWG) if output power 60 W.
1 m – 5 m	1.00 (AWG17)
6 m	1.00 (AWG17)
7 m	1.00 (AWG17)
8 m	1.50 (AWG15)
9 m	1.50 (AWG15)
10 m	2.50 (AWG13)

Fig. 6-7: Required cable cross-sections for the 24 VDC voltage supply in relation to cable length and output power

## 6.2.4 Example for a Voltage Supply of Several UPS Integrated in Control Cabinets by a High-performance Main UPS

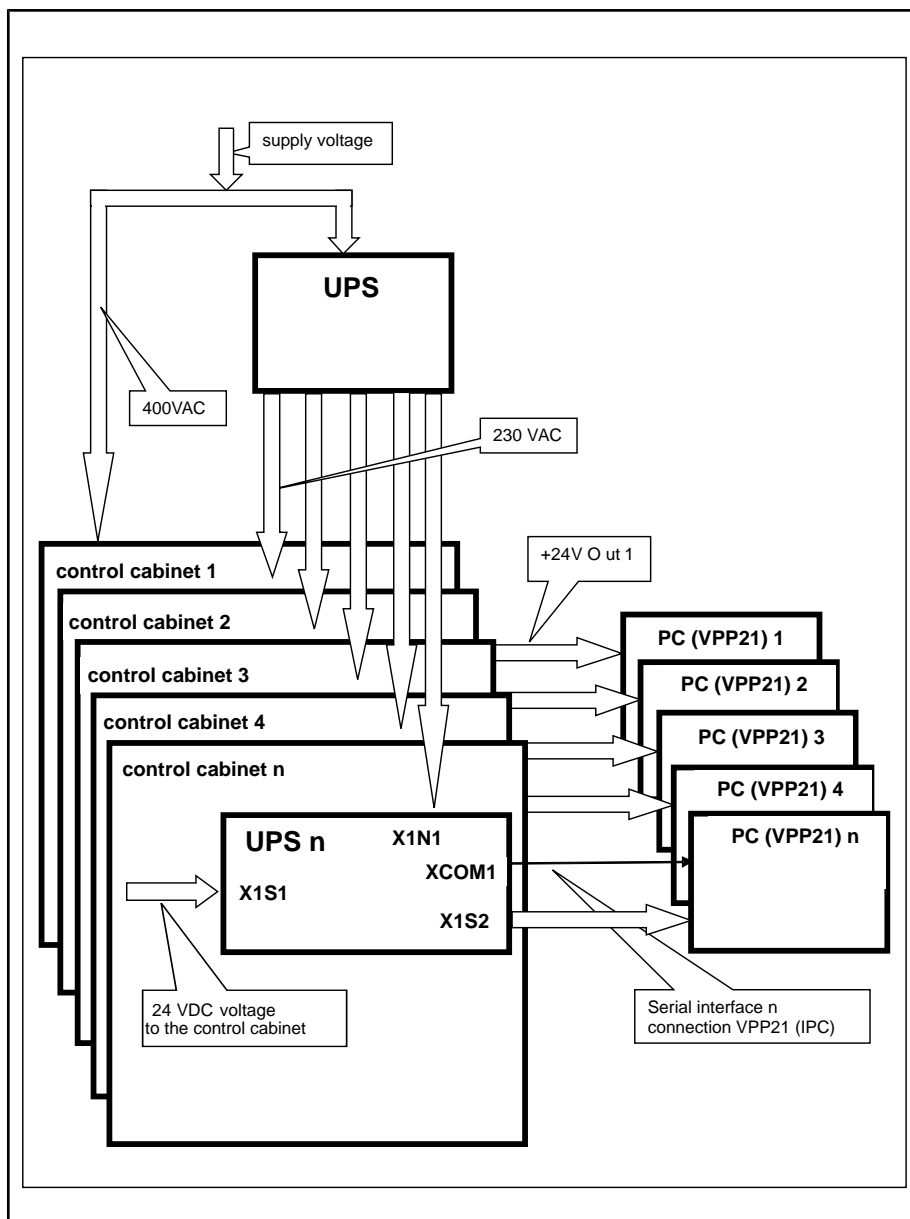

Fig.6-8: Example of a voltage supply of several control cabinets

## 6.3 Serial Interface XCOM1

### 6.3.1 General Information



Malfunctions due to insufficient shielding!

Use only shielded cables and metallic/conductive connector or coupling covers with large-area shield support.

The electrical properties of the XCOM interface correspond to the properties of the standard COM interface. However, the signals have another meaning (see [fig. 6-11 "Pin assignment XCOM1"](#) on page 27 and [chapter 6.3.2 "Description of the COM Interface"](#) on page 27).

Interfaces, Display and Operating Components

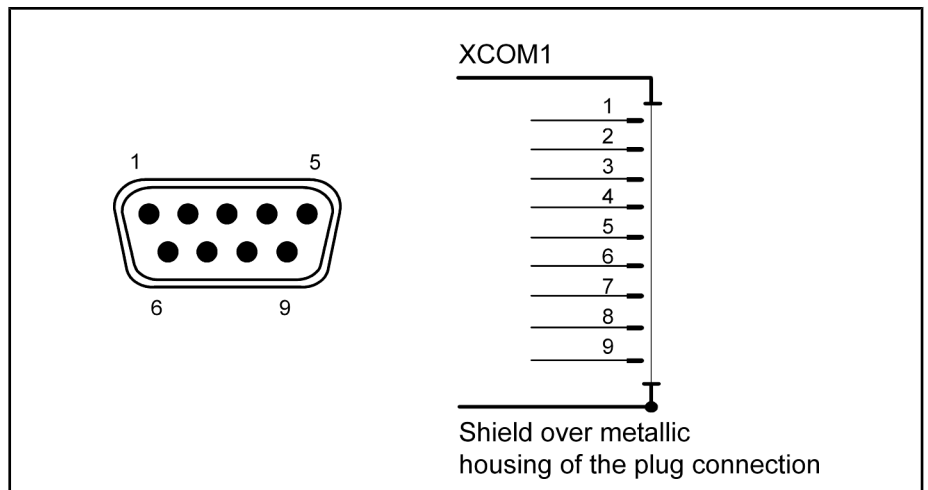

Fig.6-9: Assignment of the serial interface XCOM1

**Serial interface XCOM1** **D-Sub male connector, 9-pin**

<b>Type:</b>	RS232
<b>Cable length:</b>	20 m max.
<b>Cable type:</b>	Shielded, cross-section min. 0.08 mm <sup>2</sup> (AWG28) Stock number: 1070089307 (3m)

Fig.6-10: Serial interface XCOM1

Pin	Name	Function	Remark
4	DTR	Start of the AC power supply unit test	AC power supply test is started
5	GND		Electrically isolated to 24V GND
6	DSR	Monitoring the output voltage AC power supply unit	Signalizing the output voltage of the AC power supply unit
7	RTS	PC OK	Voltage applied to the PC, PC ready for operation
8	CTS	Message UPS operation to the PC	UPS operation initiated

Fig.6-11: Pin assignment XCOM1



The basic function of the UPS is also guaranteed without a connection to a PC. The AC power supply unit test does not belong to the basic functions.

### 6.3.2 Description of the COM Interface

CTS / UPS -> PC	UPS operation initiated	HIGH LEVEL (+5 V)	The CTS signal indicates after a time delay of 5 s that the UPS operation was initiated.
	No UPS operation	LOW LEVEL (-5 V)	Requirement: The input voltage of the UPS is fallen below +20 V. See also description of rotary switch S1.

## Interfaces, Display and Operating Components

DSR / UPS -> PC	AC power supply unit OK	HIGH LEVEL (+5 V)	The DSR signal indicates whether the AC POWER SUPPLY UNIT is ready. If the input voltage is not connected to the AC power supply unit or if the AC power supply unit is defective, the red LED "Voltage Error X1N1" is triggered.
	AC power supply unit is defective or discharged	LOW LEVEL (-5 V)	
RTS / PC ->UPS	PC OK	HIGH LEVEL (+5 V)	The RTS signal indicates to the UPS, if the PC has booted. It is also indicated, if <ul style="list-style-type: none"> <li>the PC is supplied with voltage via the UPS,</li> <li>the COM interface is connected to the PC,</li> <li>if the PC and the UPS software were started</li> </ul>
	PC not OK	LOW LEVEL (-5 V)	
DTR / PC -> UPS	Stop of the AC power supply unit test	HIGH LEVEL (+5 V)	The DTR signal starts the AC power supply unit test. For this, the RTS signal must additionally have HIGH LEVEL. Independent of the signal level of the DTR signal, a timer within the UPS switches off the internal test load of 500 mA after max. 10 seconds if beforehand the AC power supply unit test was started.
	Start of the AC power supply unit test	LOW LEVEL (-5 V)	

Fig.6-12: Description of the COM interface signals

## 6.4 Operating Display and Error Display

To indicate device states four LEDs are arranged at the front panel of the UPS.

Start the measures specified in the following [fig. 6-13 "Description of the LEDs" on page 28](#) if one of the succeeding LEDs displays an error or a note.

LED	Display	Designation	Meaning	Measure
1	24 V IN	LED green	Normal mode	-
		LED off	24 V DC missing	Check the connection cable of the supply voltage applied to the X1S2.
2	UPS OK	LED green	Normal mode	-
		LED off	Internal voltages missing	Check the two SMD fuses (see <a href="#">fig. 6-14 "Position of the two SMD fuses" on page 29</a> ). T2.5 A with UL certification
3	PC OK	LED green	Normal mode	
		LED off	Serial interface cable (UPS – PC ) is not plugged in or defective.	Check interface cable
			Connected PC power supply unit has no supply voltage or has not started	Check the PC cable connected to the X1S2.
	UPS software has not started or is not installed.	Check the connected PC		
4	Voltage error X1N1	LED red	AC power supply unit is defective or not connected.	Check the 115V/230 VAC voltage or the FKS fuse on the front
		LED off	Normal mode.	-

Fig.6-13: Description of the LEDs

## 6.5 Fuses

The UPS is provided with 3 fuses. The FKS fuse (4 A, 32 V) can be reached via the front panel (F1 connection). Both SMD fuses are located on the board. Refer to Fig. 6-12.



Fig. 6-14: Position of the two SMD fuses



**DANGER**

### Risk to damage the UPS due to short-circuits!

Disconnect the UPS from the power supplies, before opening the device to check or change a fuse!

If required, unplug all connectors from the VAU.



**CAUTION**

### Risk to damage the UPS by electrostatic discharges!

Comply with all ESD protection measures when a fuse is changed or checked!  
Avoid electrostatic discharges!

## 6.6 Rotary Switch S1

### 6.6.1 General Information

With the rotary switch different UPS times can be set. By using the switch position from 0 to 3 the UPS time can be changed in steps of one minute. The UPS time is the time period in which the connected device is provided with output voltage of the UPS - after switching off of the input voltage.

Interfaces, Display and Operating Components

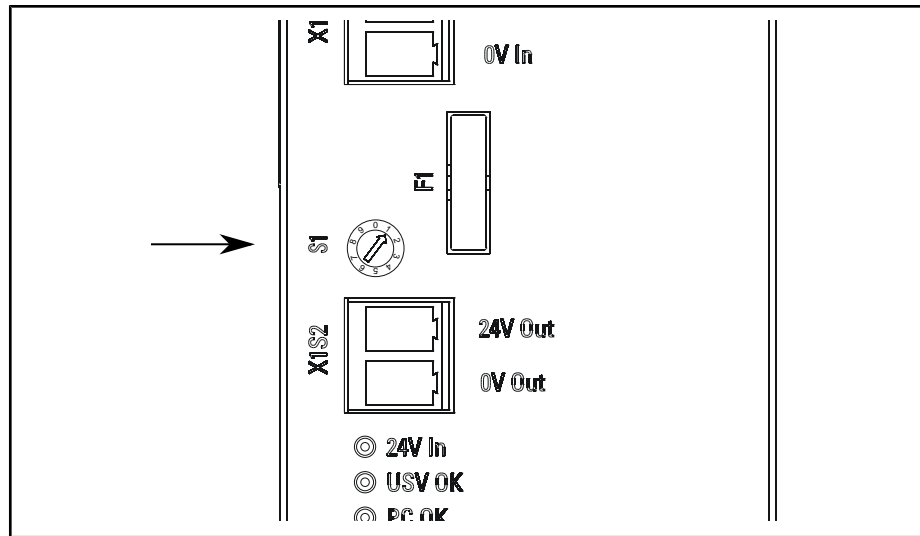

Fig.6-15: Position of rotary switch S1

Switch position	UPS operation for	Remark
0	5 seconds	①
1	1 minute	①
2	2 minutes	①
3	3 minutes	①
4	5 seconds	②
5	1 minute	②
6	2 minutes	②
7	3 minutes	②

- ① Additionally, the UPS is provided with a timer preventing that the UPS operation is signaled to the connected PC and initiated during the first 120 seconds after switching on the UPS. The output voltage of the UPS is buffered by an integrated accumulator and thus remains available for the connected PC. The UPS becomes active after 120 s. When a voltage breakdown occurs, the set time of the UPS applies (switch position 0 to 3). Thus, it is ensured that a voltage breakdown of the supply voltage does not effect the initialization phase of the connected PC in any way.
- ② The time delay of 120 seconds is switched off by using the switch positions 4 to 7. Thus, unnecessary waiting times, e.g. during commissioning, are avoided. After commissioning, it is to be reset to the switch positions 0 to 3.

Fig.6-16: Switch position

### 6.6.2 Timing with Regard to the Position of Rotary Switch S1

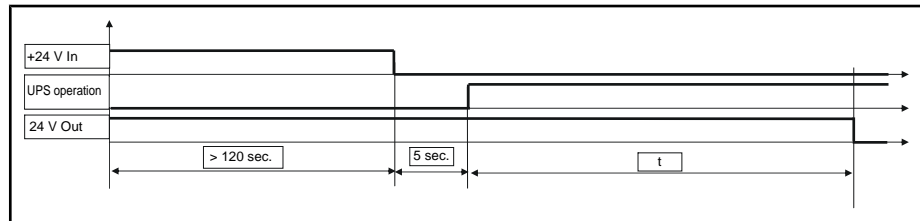

Fig.6-17: Timing

Interfaces, Display and Operating Components

Switch position S1	Time t
0	5 seconds
1	1 minute
2	2 minutes
3	3 minutes
4	5 seconds
5	1 minute
6	2 minutes
7	3 minutes

Fig. 6-18: Switching off the UPS after a starting time > 120 seconds

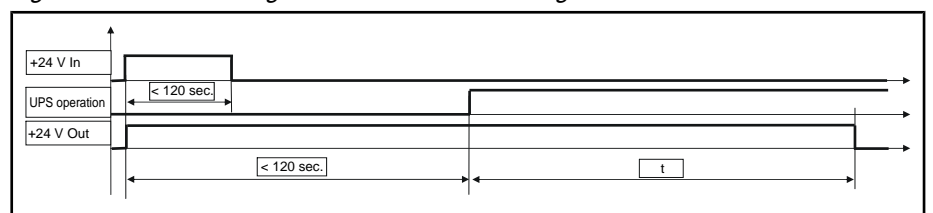

Fig. 6-19: Timing

Switch position S1	Time t
0	5 seconds
1	1 minutes
2	2 minutes
3	3 minutes

Fig. 6-20: Switching off the UPS after a starting time < 120 seconds for switch positions 0 to 3

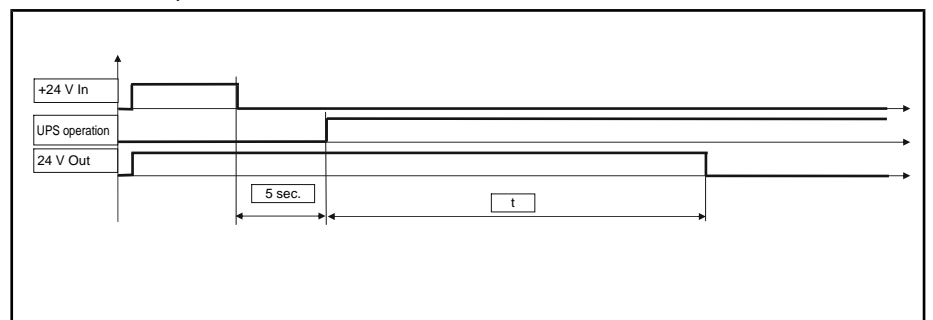

Fig. 6-21: Timing

Switch position S1	Time t
4	5 seconds
5	1 minute
6	2 minutes
7	3 minutes

Fig. 6-22: Switching off the UPS after a starting time < 120 seconds for switch positions 4 to 7

Interfaces, Display and Operating Components

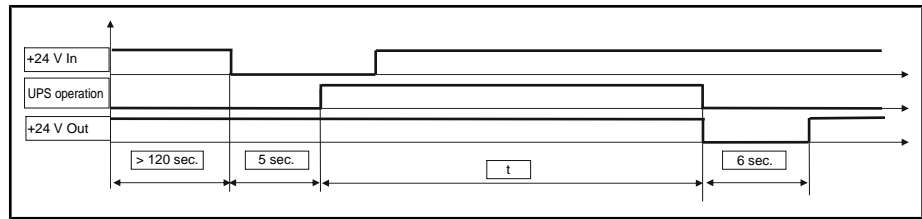

Fig. 6-23: Timing

Switch position S1	Time t
0	5 seconds
1	1 minute
2	2 minutes
3	3 minutes
4	5 seconds
5	1 minute
6	2 minutes
7	3 minutes

Fig. 6-24: Activation of the supply voltage during UPS operation

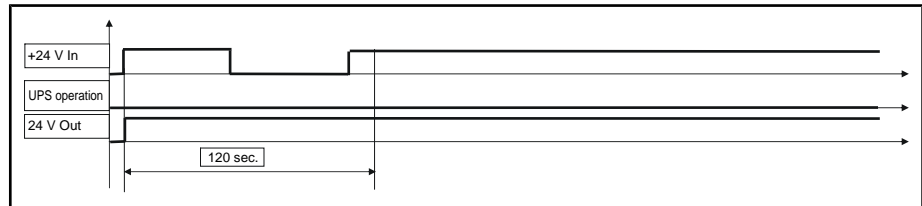

Fig. 6-25: Timing

Switch position S1	Time t
0	5 seconds
1	1 minutes
2	2 minutes
3	3 minutes

Fig. 6-26: Switching on, switching off and and switching on again for switch positions 0 to 3

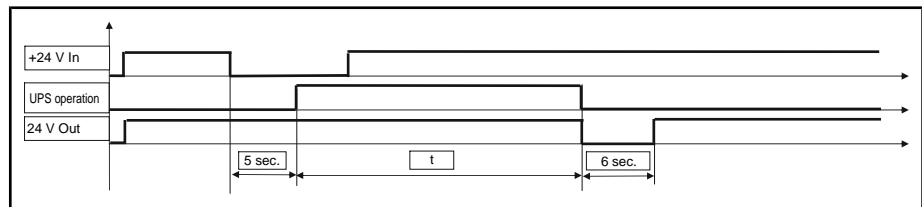

Fig. 6-27: Timing

Switch position S1	Time t
4	5 seconds
5	1 minute

## Interfaces, Display and Operating Components

Switch position S1	Time t
6	2 minutes
7	3 minutes

*Fig. 6-28: Switching on, switching off and switching on again for switch positions 4 to 7*



## 7 Maintenance and Installation

### 7.1 General Information

The UPS is maintenance-free.



**CAUTION**

---

#### **Maintenance work in the device is only permissible by skilled staff!**

If hardware or software components are to be exchanged, please contact the Bosch Rexroth Service or ensure that only skilled staff exchanges the respective components.

---

#### **Maintenance**

Include the following measure in your maintenance schedule:

- At least once a year, all plug and terminal connections of the components are to be checked regarding proper tightness and possible damage. Verify that lines and cables are not broken or squeezed. Damaged parts must be replaced immediately.



Function compatibility for spare parts is ensured for at least five years.

---



## 8 Environmental Protection and Disposal

### 8.1 Environmental Protection

<b>Production Processes</b>	The products are made with energy- and resource-optimized production processes which allow re-using and recycling the resulting waste. We regularly try to replace pollutant-loaded raw materials and supplies by more environment-friendly alternatives.	
<b>Prohibited Substances</b>	We guarantee that our products include no substances according to the chemicals-ban-decree. We furthermore declare that our products are free of mercury, asbestos, PCB and chlorinated hydrocarbons.	
<b>No Release of Hazardous Substances</b>	Our products do not contain any hazardous substances which may be released in the case of appropriate use. Normally, our products will not have any negative influences on the environment.	
<b>Significant Components</b>	Basically, our products contain the following components:	
	<b>Electronic devices</b> <ul style="list-style-type: none"> <li>• steel</li> <li>• aluminium</li> <li>• copper</li> <li>• synthetic materials</li> <li>• electronic components and modules</li> </ul>	<b>Motors</b> <ul style="list-style-type: none"> <li>• steel</li> <li>• aluminium</li> <li>• copper</li> <li>• brass</li> <li>• magnetic materials</li> <li>• electronic components and modules</li> </ul>

### 8.2 Disposal

<b>Return of Products</b>	<p>Our products can be returned to our premises free of charge for disposal. It is a precondition, however, that the products are free of oil, grease or other dirt. Furthermore, the products returned for disposal must not contain any undue foreign material or foreign components.</p> <p>Send the products "free domicile" to the following address:</p> <p style="text-align: center;">Bosch Rexroth AG Electric Drives and Controls Buergermeister-Dr.-Nebel-Strasse 2 97816 Lohr am Main, Germany</p>
<b>Packaging</b>	<p>The packaging materials consist of cardboard, wood and polystyrene. These materials can be recycled anywhere without any problem.</p> <p>For ecological reasons, please refrain from returning the empty packages to us.</p>
<b>Recycling</b>	<p>Most of the products can be recycled due to their high content of metal. In order to recycle the metal in the best possible way, the products must be disassembled into individual modules.</p> <p>Metals contained in electric and electronic modules can also be recycled by means of special separation processes. The synthetic materials remaining after these processes can be thermally recycled.</p> <p>If the products contain batteries or accumulators, these have to be removed before recycling and disposed of.</p>



# 9 Ordering Information

## 9.1 Type Designation Code

The UPS has the following features according to the type code illustrated below.

Abbrev. Column	1	2	3	4	5	6	7	8	9	1	2	3	4	5	6	7	8	9	2	1	2	3	4	5	6	
Example:	V	A	U	0	1	.	1	S	-	0	2	4	-	0	2	4	-	2	4	0	-	N	N			
<b>Product</b>	UPS for IndraControl V = VAU																									
<b>Line</b>	01..... = 01																									
<b>Design</b>	1..... = 1																									
<b>Type of construction</b> ①	Standard ..... = S				Standard with USB interface . . . = U				Control for central UPS. . . . . = Z																	
<b>Input voltage</b> ①	DC 24 V ..... = 024				AC 230 V +-10%, 50/60 Hz. . . . . = 230				DC 24 V + AC 100...240 V, 50/60 Hz = Z24																	
<b>Output voltage</b> ①	DC 24 V ..... = 024				AC 230 V +-10%, 50/60 Hz. . . . . = 230																					
<b>Maximum power</b> ①	e.g. 240 W. . . . . = 240																									
<b>Other design</b>	none . . . . . = NN																									
<b>Note</b>	<p><b>Available configurations</b></p> <p>VAU01.1S-024-024-240-NN</p> <p>VAU01.1S-230-230-300-NN</p> <p>VAU01.1U-024-024-240-NN</p> <p>VAU01.1Z-Z24-024-060-NN</p>																									

Fig.9-1: Type code for the UPS



This documentation describes only the 24 V variant of the UPS. The 230 V variant is described in the documentation of the control cabinet PC for which the 230 V UPS is offered.

Ordering Information

## 9.2 VAU 01.1S Accessories

Ordering designation	Parts number	Description
AKKU 24V/2,5Ah	1070923287	Battery
KABEL 9POL USV 3m	1070089307	RS232 cable, 3 m

Fig.9-2: Parts number - VAU 01.1S accessories

## 9.3 VAU 01.1U Accessories

Ordering designation	Parts number	Description
AKKU 24V/2,5Ah	1070923287	Battery
RKB0019/000,5	R911171165	USBA/USBB cable 0.5 m
RKB0019/001,0	R911171166	USBA/USBB cable 1 m
RKB0019/003,0	R911171166	USBA/USBB cable 3m
USB_A/B_EMV_3M	R911171414	EMC USB cable

Fig.9-3: Parts numbers - VAU 01.1U accessories

## 10 Service and Support

Our service helpdesk at our headquarters in Lohr, Germany, will assist you with all kinds of enquiries. Out of helpdesk hours please contact our German service department directly.

	Helpdesk	Service Hotline Germany	Service Hotline Worldwide
<b>Time</b> <sup>1)</sup>	Mo-Fr 7:00 am - 6:00 pm CET	Mo-Fr 6:00 pm - 7:00 am CET Sa-Su 0:00 am - 12:00 pm CET	Outwith Germany please contact our sales/service office in your area first.  For hotline numbers refer to the sales office addresses on the Internet.
<b>Phone</b>	+49 (0) 9352 40 50 60	+49 (0) 171 333 88 26 or +49 (0) 172 660 04 06	
<b>Fax</b>	+49 (0) 9352 40 49 41	–	
<b>e-mail</b>	<a href="mailto:service.svc@boschrexroth.de">service.svc@boschrexroth.de</a>	–	
<b>Internet</b>	<a href="http://www.boschrexroth.com">http://www.boschrexroth.com</a>		
	You will also find additional notes regarding service, maintenance (e.g. delivery addresses) and training.		

1) Central European Time (CET)

### Preparing Information

For quick and efficient help please have the following information ready:

- detailed description of the fault and the circumstances
- information on the type plate of the affected products, especially type codes and serial numbers
- your phone, fax numbers and e-mail address so we can contact you in case of questions.



# Index

## A

Air pressure.....	16
Appropriate use	
Introduction .....	5
Appropriate Use	
Areas of use and application .....	5

## C

CE marking.....	17
Contained substances	
see "significant components" .....	37

## D

Declaration of conformity.....	17
Dimensions.....	19
Installation .....	19
Display and operating components.....	21
Documentation.....	4

## H

Hazardous substances.....	37
---------------------------	----

## I

Inappropriate use.....	5
Consequences, exclusion of liability .....	5
Input voltage.....	15
Installation	
Installation notes .....	19
Interfaces.....	21

## M

Maintenance	
General information .....	35
Max. shock.....	16
Max. temperature gradient.....	16
Max. vibration.....	16

## O

Operating display and error display.....	28
--	----

## O

Output voltage.....	15
---------------------	----

## P

Packaging.....	37
Production processes.....	37
Prohibited substances.....	37

## R

Relative humidity.....	16
Return of Products.....	37
Rotary switch.....	29

## S

safety instructions for electric drives and controls	7
Serial interface XCOM1.....	26
Service Hotline.....	41
Significant components.....	37
Support	
see Service Hotline .....	41
Surrounding air temperature.....	16
System presentation	
VAU .....	3

## T

Technical data.....	15
Ambient conditions .....	16
Degree of protection .....	15
Used standards .....	16
Voltages .....	15
Weight .....	15

## U

UL/CSA certified.....	18
Use.....	5

## V

Voltage	
Input voltage .....	15
Output voltage .....	15



# Notes

Bosch Rexroth AG  
Electric Drives and Controls  
P.O. Box 13 57  
97803 Lohr, Germany  
Bgm.-Dr.-Nebel-Str. 2  
97816 Lohr, Germany  
Tel. +49 (0)93 52-40-0  
Fax +49 (0)93 52-48 85  
[www.boschrexroth.com](http://www.boschrexroth.com)

