

Rexroth IndraControl S67 Digital Module

8 Outputs – 2.0 A (8×M8)

Application Description
R911329562

Edition 04



Title Rexroth IndraControl S67
 Digital Module
 8 Outputs – 2.0 A (8×M8)

Type of Documentation Application Description

Document Typecode DOK-CONTRL-S67DO8M82A*-AP04-EN-P

Internal File Reference RS-7389bb73b1e601bb0a6846a001bea96b-4-en-US-3

Change Record

Edition	Release Date	Notes
Edition 01	2010-04	First edition
Edition 02	2012-11	Modifications, corrections
Edition 03	2014-07	Revision
Edition 05	2014-12	Corrections, supplements

Copyright © Bosch Rexroth AG 2014

This document, as well as the data, specifications and other information set forth in it, are the exclusive property of Bosch Rexroth AG. It may not be reproduced or given to third parties without its consent.

Liability The specified data is intended for product description purposes only and shall not be deemed to be a guaranteed characteristic unless expressly stipulated in the contract. All rights are reserved with respect to the content of this documentation and the availability of the product.

Editorial Department Compact Control KS (KaWa/MePe)

Table of Contents

	Page
1 About this Documentation.....	5
1.1 General information.....	5
1.2 Scope.....	5
1.3 Validity of the Documentation.....	6
1.4 Structuring the Documentation.....	7
1.5 Terms and Abbreviations.....	8
1.6 Customer feedback.....	8
2 Important Instructions on Use.....	9
2.1 Intended Use.....	9
2.1.1 Introduction.....	9
2.1.2 Use and Application Cases.....	9
2.2 Safety Devices.....	10
2.3 Information on the Operation.....	10
2.4 Unintended Use.....	10
3 Using safety instructions.....	11
3.1 Safety instructions – Structure.....	11
3.2 Explaining signal words and safety alert symbol.....	11
3.3 Symbols used.....	12
4 Device Description.....	13
4.1 General information.....	13
4.2 Connections.....	13
4.3 Labeling Options and Mounting.....	14
4.4 Display Elements.....	15
4.5 Labeling and Symbols at Rear Side.....	16
4.6 Type Plate.....	16
4.7 Schematic Diagram	17
4.8 Dimensions.....	18
4.9 Technical Data.....	18
4.9.1 Device Data.....	18
4.9.2 Module Supply.....	18
4.9.3 Communication.....	19
4.9.4 Digital Outputs.....	19
4.9.5 Actuator Selection Specifications.....	19
4.9.6 Effect of Operating States to Output.....	20
4.9.7 Electrical Isolation.....	20
4.9.8 Parameterizable Functions.....	20
4.9.9 Diagnostics I/O.....	20
4.9.10 Process Image.....	21
4.9.11 Displays.....	21
4.9.12 Standards and Approvals.....	21

Table of Contents

	Page
5 Mounting Module	23
5.1 General Information.....	23
5.2 Mounting Notes.....	23
5.3 Required Tools and Accessories for Mounting.....	23
5.4 Direct Mounting to System.....	24
5.5 Mounting on Mounting Rail (only with Bosch Rexroth Accessories).....	24
5.5.1 Fastening Mounting Rail Adapter at Module.....	24
5.5.2 Fastening Module with Mounting Rail Adapter to Mounting Rail.....	25
5.6 Mounting on Profile Rail (only with Bosch Rexroth Accessories).....	26
5.6.1 Fastening Profile Adapter on Module.....	26
5.6.2 Fastening Module with Profile Adapter to Profile Rail.....	27
5.7 Replacing Labeling Fields.....	27
5.8 Mounting Spacer in Case of Compact Arrangement.....	28
6 Connecting Data and Supply Cables	31
6.1 Notes.....	31
6.2 Required Accessories.....	32
6.3 Connecting S-BUS.....	32
6.4 Connecting Supply Cables.....	33
6.5 Connecting Actuator Cables.....	35
7 Commissioning	37
7.1 General Information.....	37
8 Process Images	39
8.1 General Information.....	39
8.2 Output Data.....	39
8.3 Input Data.....	40
9 Parameterization	43
9.1 General Information.....	43
9.2 Diagnostic Overview.....	43
9.3 Output Parameters.....	44
9.4 Global Settings for Field Supply.....	45
9.5 Automatic Storage of System Parameters.....	45
9.6 Firmware Update.....	45
10 Diagnostics via LED Signals	47
10.1 General Information.....	47
10.2 Operating Messages of the Module.....	47
11 Maintenance and Service	51
11.1 General Information.....	51
11.2 Replacing Module.....	51

Table of Contents

	Page
11.2.1	General Information..... 51
11.2.2	Disconnecting Wiring..... 51
11.2.3	Removing Module from System..... 51
11.2.4	Removing Module from Mounting Rail..... 51
11.2.5	Removing Module from Profile Adapter..... 52
11.2.6	Connecting Module..... 52
11.3	Disposal..... 52
12	Using Feedback-Free Module in Safety Applications..... 53
12.1	General Information..... 53
12.2	Important Information..... 53
12.3	General Measures and Requirements for the Module Supply Concept..... 54
12.4	Measures and Requirements for Shielded Module Voltage Supply..... 55
12.5	Measures and Requirements for Unshielded Module Voltage Supply..... 56
12.6	Connecting Module to Safety Control Devices..... 56
12.6.1	General Structure of a Potential Group..... 56
12.6.2	Connection Examples..... 57
13	Accessories..... 59
13.1	General information..... 59
13.2	Assembled S-BUS Cables..... 59
13.3	Ready-Made Supply Cables..... 61
13.4	Carrier Rail Adapter, Profile Adapter and Spacer..... 62
13.5	End Clamp..... 62
13.6	Protective caps..... 63
13.7	Module Labeling Strips..... 63
14	Appendix..... 65
14.1	Diagnostic Information..... 65
15	Service and support..... 67
	Index..... 69

1 About this Documentation

1.1 General information

Read this chapter thoroughly before using the application description.

1.2 Scope

The present documentation applies to the digital output module S67-DO8-M8-2A of the IndraControl S67 series.

For other components of the IndraControl S67 series, the following documentations are available:

Document	Title	Parts number
Module-comprehensive		
Application Description	Rexroth IndraControl S67	R911329572
Application Description	Rexroth IndraControl S67 DTM Input and Output Modules	R911340954
Field bus coupler		
Application Description	Rexroth IndraControl S67 Ethernet/IP Coupler 8 Digital Inputs (M8)	R911329564
Application Description	Rexroth IndraControl S67 Profibus Coupler 8 Digital Inputs (M8)	R911329566
Application Description	Rexroth IndraControl S67 Profinet Coupler 8 Digital Inputs (M8)	R911329568
Application Description	Rexroth IndraControl S67 Sercos Coupler 8 Digital Inputs (M8)	R911338401
Modules		
Application Description	Rexroth IndraControl S67 Digital Module 8 Outputs – 0.5 A (8×M8)	R911329560
Application Description	Rexroth IndraControl S67 Digital Module 8 Outputs – 0.5 A (4×M12)	R911329556
Application Description	Rexroth IndraControl S67 Digital Module 8 Outputs – 2.0 A (4×M12)	R911329558
Application Description	Rexroth IndraControl S67 Digital Module High Speed 8 Outputs – 0.1 A (4×M12)	R911342200
Application Description	Rexroth IndraControl S67 Digital Module 8 Outputs – 0.5 A (8×M12)	R911342196
Application Description	Rexroth IndraControl S67 Digital Module 8 Inputs (8×M8)	R911329552
Application Description	Rexroth IndraControl S67 Digital Module 8 Inputs (4×M12)	R911329500
Application Description	Rexroth IndraControl S67 Digital Module High Speed 8 Inputs (4×M12)	R911342198

About this Documentation

Document	Title	Parts number
Application Description	Rexroth IndraControl S67 Digital Module 8 Inputs (8×M12)	R911342194
Application Description	Rexroth IndraControl S67 Digital Module 8 Inputs/Outputs – 0.5 A (8×M8)	R911338695
Application Description	Rexroth IndraControl S67 Digital Module 8 Inputs/Outputs – 0.5 A (8×M12)	R911338697
Application Description	Rexroth IndraControl S67 Digital Module High Speed 4 Inputs/Outputs – 0.2 A (4×M12)	R911342202
Application Description	Rexroth IndraControl S67 Analog Module – 4 Inputs Voltage/Current (4×M12)	R911329544
Application Description	Rexroth IndraControl S67 Analog Module – 4 Inputs for the RTD (4×M12)	R911329542
Application Description	Rexroth IndraControl S67 Analog Module – 4 Inputs TC Temperature Sensors (4×M12)	R911338699
Application Description	Rexroth IndraControl S67 Analog Module – 4 Outputs Voltage/Current (4×M12)	R911329546
Application Description	Rexroth IndraControl S67 Universal Interface Module - 4 Inputs/Outputs – 0.5 A (M12)	R911339361
Application Description	Rexroth IndraControl S67 HTL Encoder, Counter Module 4 Digital Inputs/Outputs (4×M12)	R911342204
Application Description	Rexroth IndraControl S67 TTL, SSI Encoder Module 4 Digital Inputs/Outputs (4×M12)	R911342206
Application Description	Rexroth IndraControl S67 Power Distributor (6×M12)	R911329570

Tab. 1-1: Overview on the IndraControl S67 manuals

1.3 Validity of the Documentation

Overview on target groups and product phases

In the following illustration, the framed activities, product phases and target groups refer to the present documentation.

Example: In the product phase "Mounting (assembly/installation)", the target group "Mechanic/electrician" can execute the activity "Unpack, Mount and Install" using this documentation.

About this Documentation

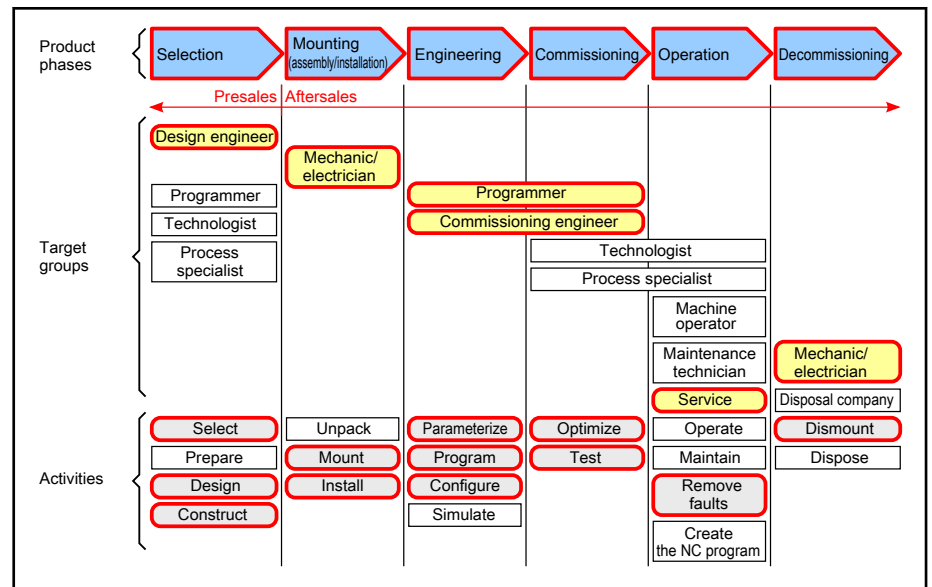

Fig. 1-1: Assigning this documentation to the target groups, product phases and target group activities

Purpose This documentation is intended for users commissioning a decentralized digital output module of type S67-DO8-M8-2A. This documentation contains general information on the output module. Mounting and cabling of the output module are also described. The basic commissioning steps and the configuration of the IndraControl S67 station are then explained.

1.4 Structuring the Documentation

The first part of the documentation contains important information on the intended use as well as information on the safety instructions ([chapter 2 "Important Instructions on Use" on page 9](#) and [chapter 3 "Using safety instructions" on page 11](#)).

For a short overview on the structure and the functions of the digital output module, refer to [chapter 4 "Device Description" on page 13](#).

For the mounting description of the module, refer to [chapter 5 "Mounting Module" on page 23](#).

For information on data and supply cables, refer to [chapter 6 "Connecting Data and Supply Cables" on page 31](#).

For the commissioning of the module, refer to [chapter 7 "Commissioning" on page 37](#).

For information on the process images of the digital output module, refer to [chapter 8 "Process Images" on page 39](#).

For the parameterization of the module, refer to [chapter 9 "Parameterization" on page 43](#).

For the diagnostic options regarding the digital output module, refer to [chapter 10 "Diagnostics via LED Signals" on page 47](#).

For information on the module exchange, refer to [chapter 11 "Maintenance and Service" on page 51](#).

For information on the module usage in safety applications, refer to [chapter 12 "Using Feedback-Free Module in Safety Applications" on page 53](#).

For information on the accessories for the digital output module, refer to [chapter 13 "Accessories" on page 59](#).

About this Documentation

For diagnostic information, refer to [chapter 14 "Appendix" on page 65](#).

For information on the customer service help desk of Bosch Rexroth, refer to [chapter 15 "Service and support" on page 67](#).

1.5 Terms and Abbreviations

Term	Explanation
CE	The CE marking (Conformité Européenne) is used by the manufacturer or EU importer according to the EU regulation 765/2008 and "indicates that the product complies with the applicable requirements specified in the Community harmonization legislation provided for its affixing"
UL	Underwriters Laboratories Inc., US organization for electrotechnical product certification
CSA	Canadian Standards Association. The CSA develops and maintains more than 3000 standards and regulations related to safety, design or performance
NEMA	National Electrical Manufacturers. The NEMA constitutes the representation of interests as well as the professional organization of the electrotechnical industry of North America
IndraWorks	Configuration and commissioning tool developed by Bosch Rexroth
VPE	Packaging unit

Tab. 1-2: Terms and abbreviations

1.6 Customer feedback

Customer requests, comments or suggestions for improvement are of great importance to us. Please email your feedback on the documentations to Feedback.Documentation@boschrexroth.de. Directly insert comments in the electronic PDF document and send the PDF file to Bosch Rexroth.

2 Important Instructions on Use

2.1 Intended Use

2.1.1 Introduction

The Rexroth products represent state-of-the-art developments and manufacturing. The products are tested prior to delivery to ensure operating safety and reliability.

The products may only be used as intended. If the products are not used as intended, situations causing personal injury as well as material damage can occur.



Rexroth shall not be liable for damages resulting from unintended use. In such cases, the guarantee and the right to payment of damages resulting from unintended use are forfeited. The user alone carries all responsibility of the risks.

Before using Bosch Rexroth products, the following requirements must be met to ensure intended use of the products:

- Personnel who in any way, shape, form or use one of our products must first read and understand the relevant safety instructions and be familiar with the intended use of the products
- If the product takes the form of hardware, they must remain in the original state, in other words, no structural changes are permitted. The de-Compilation of software products or the alteration of source codes is not permitted
- Do not install or operate damaged or faulty products
- Ensure that the products have been installed as described in the relevant documentation

2.1.2 Use and Application Cases

The S67-DO8-M8-2A module outputs digital signals specified by a parent control (e.g., programmable coupler).

The S67-DO8-M8-2A module cannot be used to control safety purpose functions, i.e., the S67-DO8-M8-2A module cannot be a functional component of a safety function.

The digital outputs of the S67-DO8-M8-2A module are feedback-free and thus not affected by internal groups of potentials. The module can only be used in a safety circuit together with a safety control device (with diagnostic function) or with other feedback-free modules. The module is not a safety-oriented component. Refer to [chapter 12 "Using Feedback-Free Module in Safety Applications" on page 53](#).

The S67-DO8-M8-2A module shall only be used in combination with a field bus coupler and I/O modules of the IndraControl S67 series.

The S67-DO8-M8-2A module was developed for applications requiring the degree of protection IP 67 (NEMA type 6, 6P).

Important Instructions on Use



The S67-DO8-M8-2A module may only be used with the accessories and mounting parts listed in this documentation. Components that are not expressly mentioned must neither be attached nor connected. The same applies to cables and lines.

Operation may only be carried out with the hardware component configurations and combinations that are expressly specified and with the software and firmware indicated and specified in the respective documentation and functional descriptions.

In case of non-compliance, the guarantee and warranty claims shall automatically expire.

The S67-DO8-M8-2A module may only be operated under the mounting and installation conditions, the position, and the ambient conditions (temperature, degree of protection, humidity, EMC, etc.) specified in the related documentation.

2.2 Safety Devices

All products of the IndraControl S67 series are designed to meet the requirements acc. to IP 67. This includes complete protection against accidental contact with electrical voltage and currents – even when wet.

2.3 Information on the Operation

To integrate the IndraControl S67 components into your machine or system, the following valid and applicable standards, guidelines and provisions have to be complied with: e.g., BGV A 3, "Electrical Systems and Equipment", DIN EN 418, EN 60204. The E-Stop devices shall remain effective in all operation modes of the system and machine.

To protect against electromagnetic interferences:

- Connect your system to protective earth (PE)
- Ensure that the cable routing and the installation of the field bus, S-BUS and supply cables as well as sensor and actuator cables are correctly connected

The following measures have to be available for a 24 V supply:

- Outer lightning protection on buildings
- Inner lightning protection of supply and signal lines
- Safe electrical separation of extra-low voltage 24 V DC through PELV (protective extra-low voltage) or SELV (safety extra-low voltage) voltage sources.

2.4 Unintended Use

Using the S67-DO8-M8-2A module in areas of applications other than the modules specified or described in the documentation and the technical specifications is considered as "unintended".

The S67-DO8-M8-2A module must not be used in case of

- operating conditions which do not meet the specified ambient conditions. Operation under water, extreme temperature fluctuations or extreme maximum temperatures is prohibited
- Use in household devices or devices belonging to the categories 1 to 7 and 10 specified in Appendix IA of the Directive 2002/96/EC ("WEEE")

3 Using safety instructions

3.1 Safety instructions – Structure

The safety instructions are structured as follows:

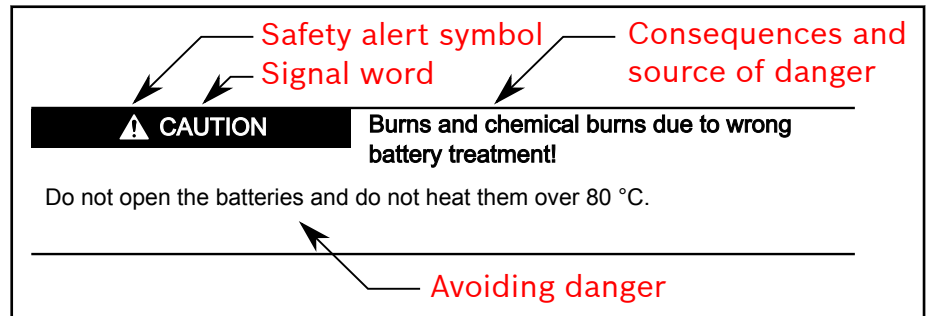

Fig. 3-1: Safety instructions – structure

3.2 Explaining signal words and safety alert symbol

The safety instructions in this documentation contain specific signal words (danger, warning, caution, notice) and, if necessary, a safety alert symbol (according to ANSI Z535.6-2006).

The signal word is used to draw attention to the safety instruction and also provides information on the severity of the hazard.

The safety alert symbol (a triangle with an exclamation point), which precedes the signal words danger, warning and caution is used to alert the reader to personal injury hazards.

⚠ DANGER

In the event of non-compliance with this safety instruction, death or serious injury **will** occur.

⚠ WARNING

In the event of non-compliance with this safety instruction, death or serious injury **will** occur.

⚠ CAUTION

In the event of non-compliance with this safety instruction, minor or moderate injury can occur.

NOTICE

In the event of non-compliance with this safety instruction, material damage can occur.

Using safety instructions

3.3 Symbols used

Pointers are displayed as follows:



This is a note.

Tips are displayed as follows:



This is a tip.

4 Device Description

4.1 General information

The positive-switching S67-DO8-M8-2A module controls magnetic valves, contactors, encoders, relays and other electric loads. The module is provided with multiple parameterization options for a fine adjustment of its function. It is parameterized via a field bus coupler. Furthermore, the S67-DO8-M8-2A module has a module-related diagnostics.



For detailed information on the module parameterization using the field bus, refer to the corresponding documentation (e.g. "Rexroth IndraControl S67 Profibus Coupler 8 Digital Inputs (M8)").



For detailed information on the S67-DO8-M8-2A module properties, refer to [chapter 4.9 "Technical Data" on page 18](#).

4.2 Connections

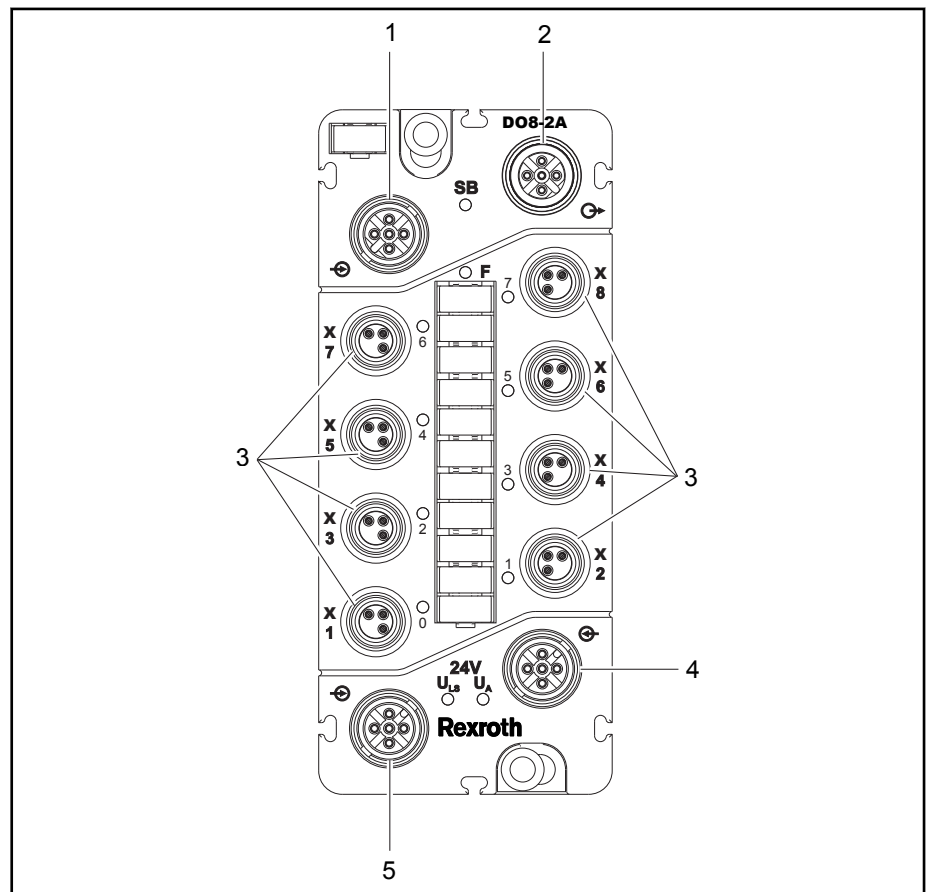

Fig. 4-1: ID of the module connections

Device Description

Position	Description	Function
1	S-BUS input M12 plug, B-coded	To transmit data of the previous IndraControl S67 component
2	S-BUS output M12 socket, B-coded	Forwarding the S-BUS to the next IndraControl S67 component or to the termination of the S-BUS
3	Digital outputs 1 – 8 M8 socket	To connect digital actuators (e.g., magnetic valves or contactors)
4	Supply input M12 plug, A-coded	To provide logic, sensor and/or actuator supply for the following I/O module
5	Supply input M12 plug, A-coded	Feeding U_{LS} (logic and sensor voltage) and U_A (actuator voltage)

Tab. 4-1: ID of the module connections

4.3 Labeling Options and Mounting

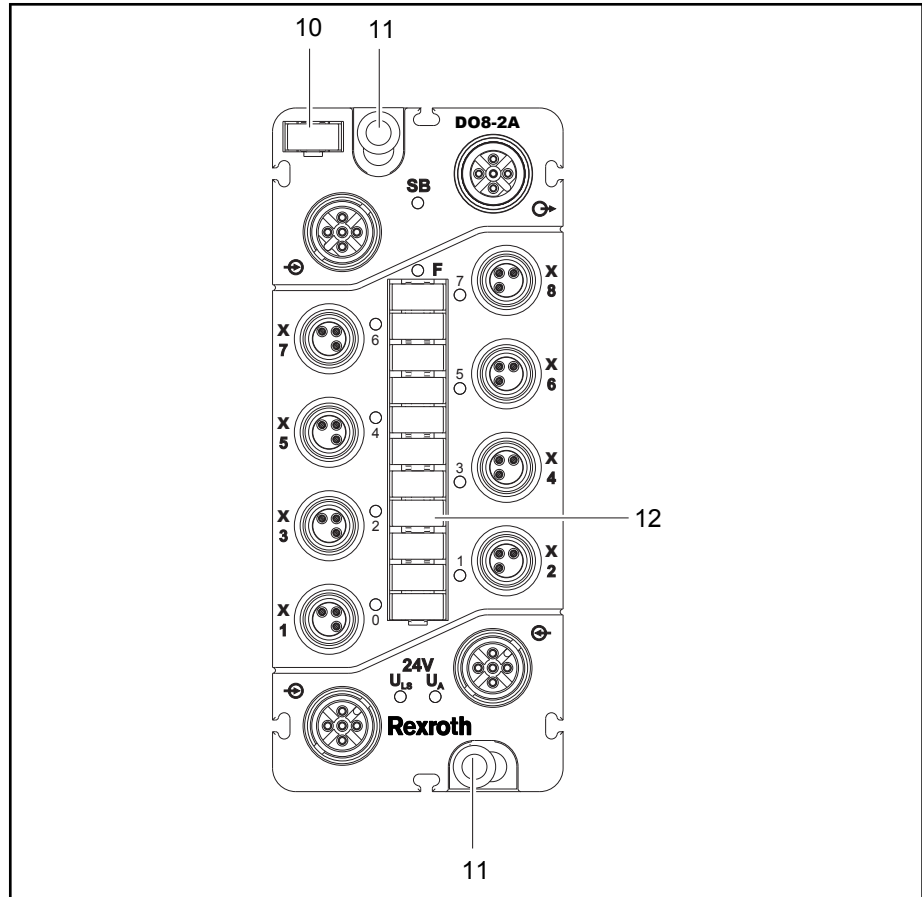

Fig. 4-2: Identifying options for labeling and mounting

Position	Description	Function
10	Module labeling plate	To identify the module in a field bus node
11	Mounting holes	Mounting and grounding the module using M4 screws
12	Labeling strips	To identify connections

Tab. 4-2: Identifying options for labeling and mounting

4.4 Display Elements

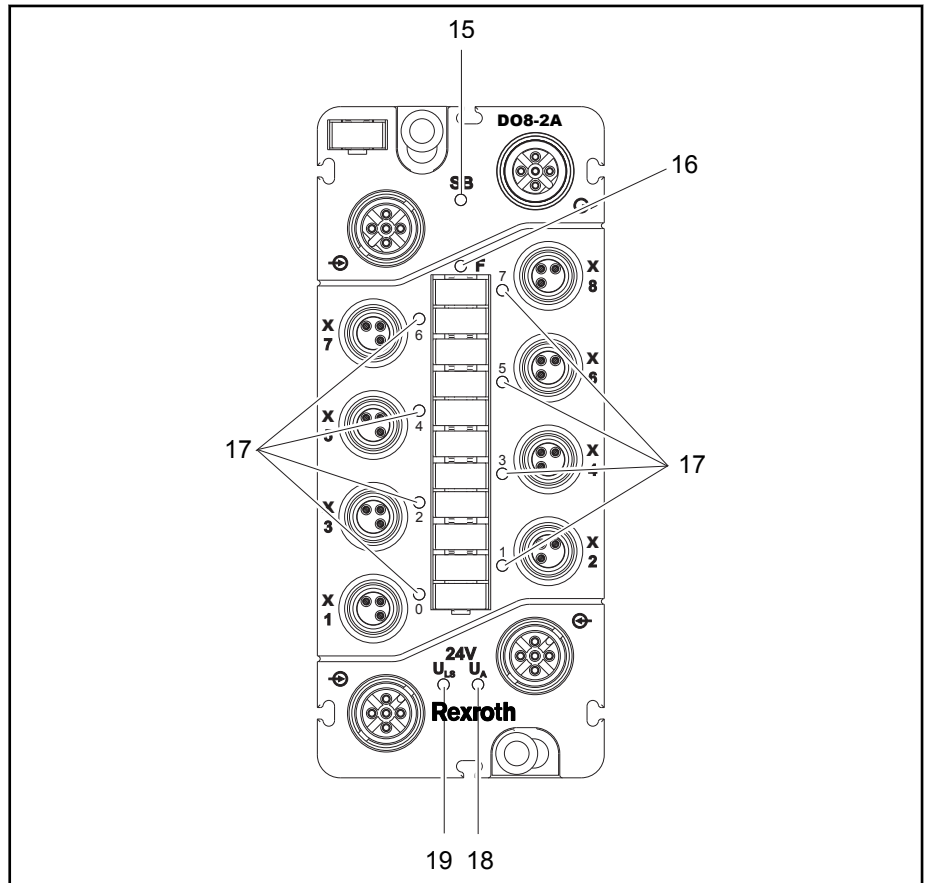

Fig. 4-3: Identifying module LEDs

Position	LED	Color	Meaning
15	SB	Green/red/orange	S-BUS status
16	F	Red	Diagnostic information
17	0 to 7	Yellow/red	Signal status of the outputs
18	U _A	Green	Actuator supply present
19	U _{LS}	Green	Logic supply present

Tab. 4-3: Identifying module LEDs

For detailed information, refer to [chapter 10.2 "Operating Messages of the Module"](#) on page 47.

Device Description

4.5 Labeling and Symbols at Rear Side

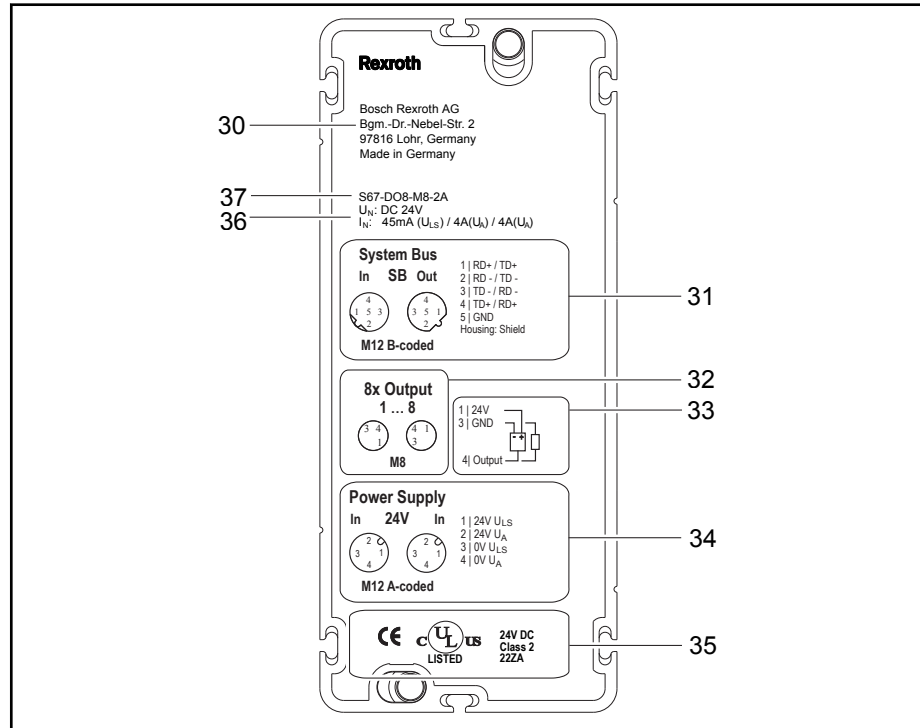

Fig. 4-4: Labeling and symbols

Position	Description
30	Manufacturer address
31	S-BUS pin assignment
32	Digital output pin assignment
33	Pin example
34	Pin assignment of supply input and output
35	Information on approval and CE mark
36	Power consumption and voltage specifications
37	Module name

Tab. 4-4: Labeling and symbols

4.6 Type Plate

A label is attached to the side of the module. This label contains important information used for tracing in case of claims or complaints:

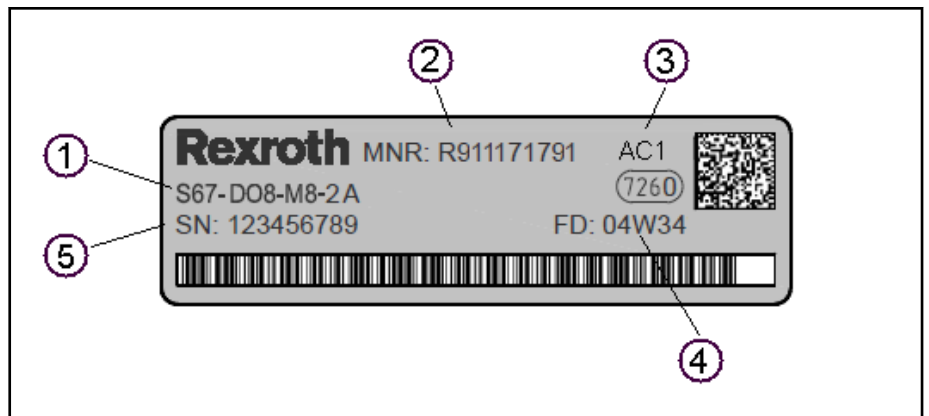

- ① Type code
 - ② Parts number
 - ③ Technical index
 - ④ Date of manufacture
 - ⑤ Serial number
- Fig. 4-5: Type plate

4.7 Schematic Diagram

The following schematic diagram provides an overview on the power supply and the mode of operation of power supply connections as well as the digital module outputs (see also [chapter 6.4 "Connecting Supply Cables" on page 33](#) and [chapter 6.5 "Connecting Actuator Cables" on page 35](#)).

Note that the common field supply of the actuators is distributed to all module connections (X1 – X8, pin 1).

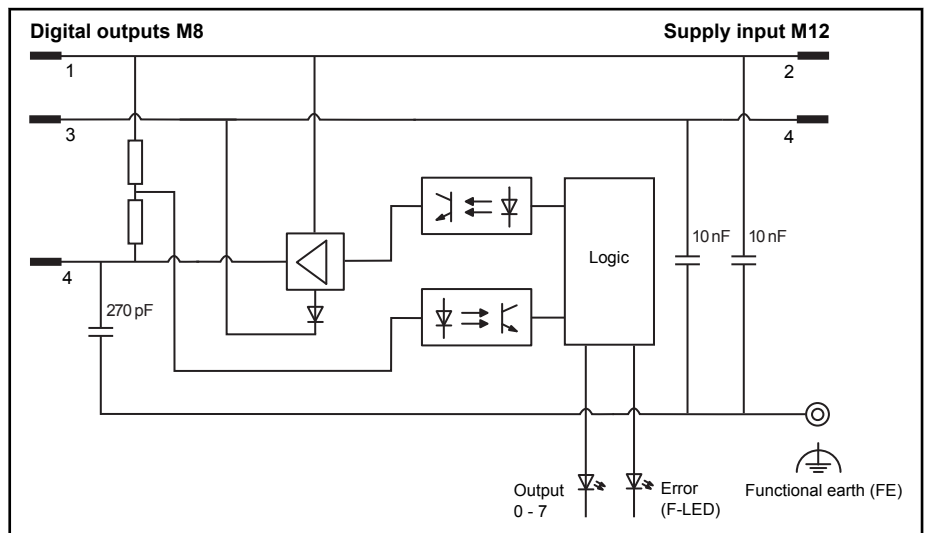

Fig. 4-6: Schematic diagram

Device Description

4.8 Dimensions

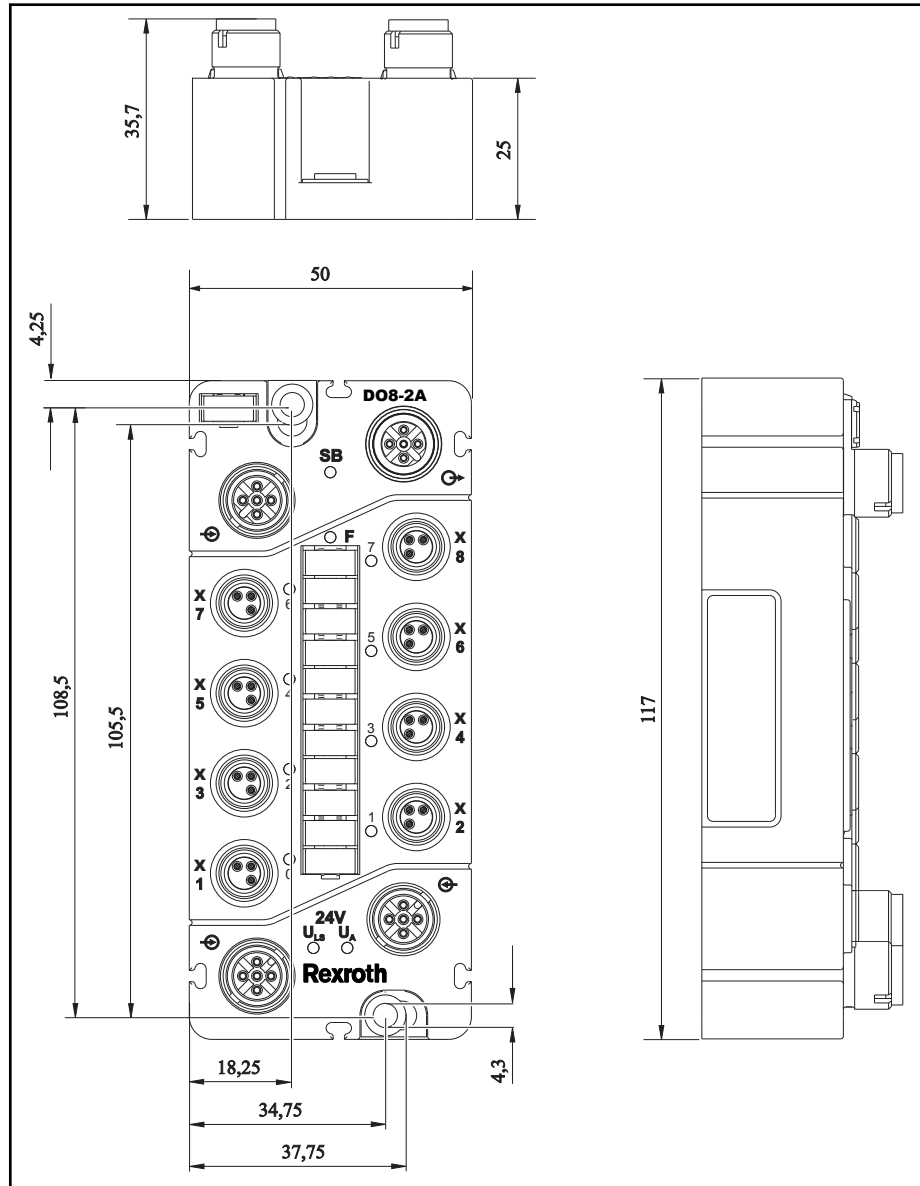

Fig. 4-7: Module dimensions in millimeters

4.9 Technical Data

4.9.1 Device Data

Dimensions (mm) W × H × D	50 × 117 × 35,7
Weight	Ca. 277 g

Tab. 4-5: Device data

4.9.2 Module Supply

Connection type	M12 male connector, A-coded, 4-pin [Ⓞ]
Current-carrying capacity of supply connections	Maximum: 8 A (U _{LS} : 4 A, U _A : 4 A)

Device Description

Supply voltage	
Logic and sensor voltage U_{LS}	DC 24 V (-25 % ... +30 %)
Actuator voltage U_A	DC 24 V (-25 % ... +30 %)
Supply current	
Logic and sensor current I_{LS}	Typically 45 mA (logic component only)
Actuator current I_A	Typically 55 mA + actuator
Protection function	Reverse polarity protection for $U_{LS} + U_A$

⊕ Derating has to be complied with

Tab. 4-6: *Module supply*

4.9.3 Communication

S-BUS connection	Shielded M12 male connector, B-coded, 5-pin
------------------	---

Tab. 4-7: *Communication*

4.9.4 Digital Outputs

Number of outputs	8
Connection type	M8 male connectors, 3-pin
Termination technique	2- to 3-wire
Output voltage	$\leq U_A$
Output current (per channel)	2.0 A (max. 2.4 A), Short-circuit/overload proof (thermal shutdown)
Voltage drop against U_A at 2.0 A	Maximum 0.2 V DC
Output current (module)	Maximum 8 A
Leakage current when switched off	Typically 780 μ A
Output circuit	High-side switching

Tab. 4-8: *Digital outputs*

4.9.5 Actuator Selection Specifications

Delay time HW	
From 0 to 1 (0 – 90 %)	Typically 75 μ s (ohmic load)
From 1 to 0 (0 – 90 %)	Typically 265 μ s (ohmic load)
Rise time	
From 0 to 1	Typically 30 μ s (ohmic load)
Drop-out time	
From 1 to 0	Typically 50 μ s (ohmic load)
Cable length, unshielded	≤ 30 m
Strength against reverse voltages	≤ 2 A
Load type	Inductive, ohmic loads and lamps

Device Description

Switching frequency	Inductive load, approx. 20 Hz Ohmic load, approx. 500 Hz Lamp load, approx. 500 Hz
Recommended minimum load	50 mA*
Parallel switching of 2 outputs	For power increase For redundant load actuation
Type of protective circuit	External protection (e.g. free-wheeling diodes)
Output resistance	Maximum 0.4 Ω

* Incorrect diagnostics can be caused by high switching frequencies with low load

Tab. 4-9: Information on the actuator selection

4.9.6 Effect of Operating States to Output

CPU stop of PLC	Acc. to substitute value strategy
Supply voltage under rated voltage tolerance	0 V status
Disconnection of supply voltage	0 V status
Working method of the output	Non-storing
Response in case of overload	Automatic restart

Tab. 4-10: Effect of operating states on output

4.9.7 Electrical Isolation

Channel - Channel	No
U_{LS} , U_A , S-BUS	DC 500 V each

Tab. 4-11: Electrical isolation

4.9.8 Parameterizable Functions

Substitute value strategy (per channel)	Switch substitute value/maintain last value
Substitute value (per channel)	0/1
Diagnostics (per channel/per module)	Lock/unlock

Tab. 4-12: Parameterizable functions

4.9.9 Diagnostics I/O

Per channel	Short circuit/actuator overload
Per channel	Wire breakage of actuator
Per channel	Overtemperature
Per module	Undervoltage (U_{LS} + U_A)

Tab. 4-13: Diagnostics I/O

4.9.10 Process Image

Process data width	1 byte data + status
--------------------	----------------------



Tab. 4-14: Process image

4.9.11 Displays

0 ... 7: Signal status of the outputs	LED (yellow/red)
F: Error status	LED (red)
U _{LS} + U _A : Supply status	LED (green)
SB: S-BUS status	LED (green/red/orange)
Displays	Non-storing

Tab. 4-15: Displays

4.9.12 Standards and Approvals

UL/CSA 	UL 508 (Industrial Control Equipment)
	C22.2 No. 14-95 (CSA)
	UL file no. E210730
Conformity marking 	CE

Tab. 4-16: Standards and approvals

5 Mounting Module

5.1 General Information

The S67-DO8-M8-2A module can be fastened directly to the system using screws. It can also be mounted on a mounting rail using an adapter or fastened to a profile rail using a mounting profile.

To mount on a flat surface, Bosch Rexroth provides spacers as mounting aid. The spacers can be inserted between the IndraControl S67 components. This provides sufficient mounting distance for compact direct mounting and prevents gaps where dirt can accumulate. A cable tie can be fastened through each of two eyes in the spacer, which together serve as strain relieve of the actuator cables.

5.2 Mounting Notes

Always follow the subsequent instructions:

- Disconnect the power supply from the system before mounting.
- The maximum drilling hole diameter for the fastening holes of module must not exceed 4 mm. Otherwise, there may be no full contact with the PE socket of the S67-DO8-M8-2A module and correct shielding is not possible.
- To protect the S67-DO8-M8-2A module from tensile forces, do not bridge spaces with that module
- Screw the S67-DO8-M8-2A module only on flat contact surfaces to protect it from warping
- Ensure that the connectors are not soiled during mounting. Dirt damages the contacts. Corrosion can be caused
- In order not to damage the S67-DO8-M8-2A module, do not mount it in shear areas of moving system components
- Provide sufficient potential equalization in the system
- Use all fastening holes to mount the S67-DO8-M8-2A module to the system so that all FE connections are on a ground potential.

5.3 Required Tools and Accessories for Mounting

Depending on the mounting type, the following tools are required:

- Screwdriver for M4 fastening screws
- Drilling machine to pre-drill the fastening holes to mount on the system for the S67-DO8-M8-2A module and, if applicable, for the imperforated mounting rails
- M4 thread cutter (tap or tap set)

The Bosch Rexroth accessory components listed below are required for mounting. The corresponding ordering numbers are listed in [chapter 13 "Accessories" on page 59](#).

- Mounting rail adapters including fastening screws and perforated or non-perforated mounting rails (TS 35 x 7.5 rail) acc. to EN 60715
or
- Profile adapters including fastening screws
- Spacer (optional)

Mounting Module

Two M4x12 screws are required to directly mount the S67-DO8-M8-2A module. Select the length of the screw shaft with regard to the fastening type.

Drilling dimensions

When fastening the IndraControl S67 component without a threaded hole, the clearance hole must not be wider than 4 mm to ensure a safe contact of the FE connections.

5.4 Direct Mounting to System

Mount the S67-DO8-M8-2A module directly on a flat system surface without using Bosch Rexroth accessories. To directly mount the module, proceed as follows:

1. Disconnect the power supply from those devices on which the S67-DO8-M8-2A module is to be mounted.
2. Mark the drilling holes. Use the drilling template printed on the packaging. Alternatively, position the S67-DO8-M8-2A module as desired and mark the drill holes. Ensure that there is sufficient space around the IndraControl S67 series component to connect all cables without problems.



We recommend the use of Bosch Rexroth spacers for compact direct mounting. If these spacers are used, the additional distance from the second IndraControl S67 component onwards is to be observed (see [chapter 5.8 "Mounting Spacer in Case of Compact Arrangement" on page 28](#)).

3. Fasten the S67-DO8-M8-2A module with the M4x12 screws via the two fastening holes.

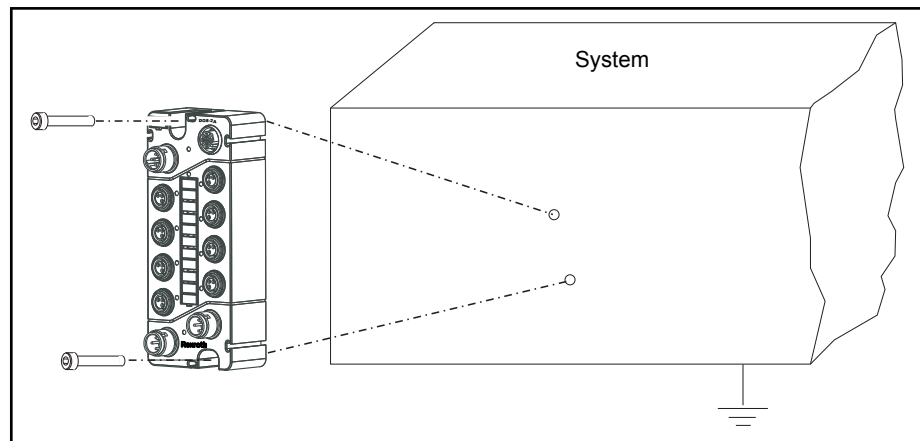

Fig. 5-1: Mount the module at a grounded frame of the system or another earth connection point

5.5 Mounting on Mounting Rail (only with Bosch Rexroth Accessories)

5.5.1 Fastening Mounting Rail Adapter at Module

A mounting rail adapter is required to mount the S67-DO8-M8-2A module on mounting rails.

Screw the S67-DO8-M8-2A module with the mounting rail adapter using the M4 threaded screws provided as shown in the figure below.

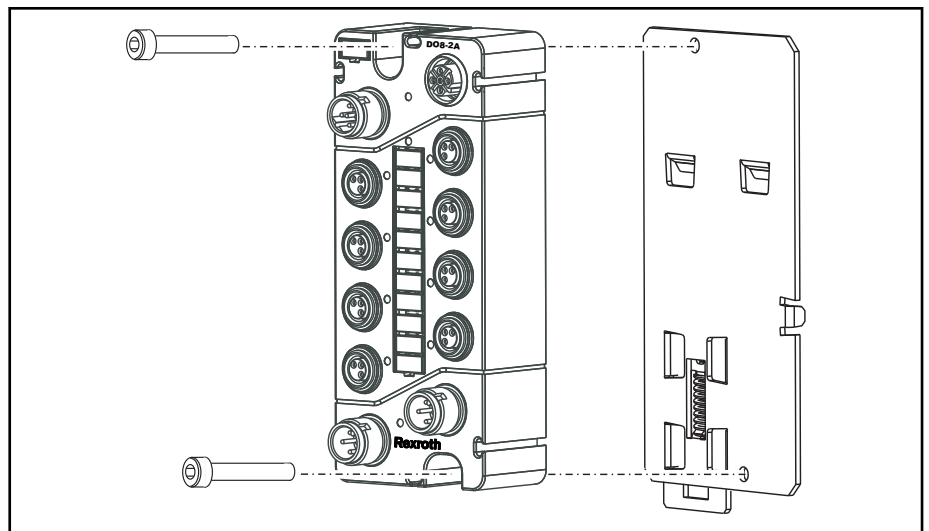

Fig. 5-2: Mounting on the mounting rail adapter

5.5.2 Fastening Module with Mounting Rail Adapter to Mounting Rail

For a clear figure, the mounting rail adapter in the figure below is shown without the S67-DO8-M8-2A module.

When mounting the S67-DO8-M8-2A module to a mounting rail (35 x 7.5 rail) using a mounting rail adapter, proceed as follows:

1. Disconnect the power supply from those devices on which the S67-DO8-M8-2A module is to be mounted.
2. Position the S67-DO8-M8-2A module to the edge of the mounting rail (51) with the two notches (50).
3. Press the lower side against the lower mounting rail edge until the latch (52) is engaged.



For vertical mounting of the mounting rail or when vibrations or shock occur, use the end clamps "SUP-M01" or "SUP-M01 AL" for stabilization (see [chapter 13.5 "End Clamp" on page 62](#)).

Mounting Module

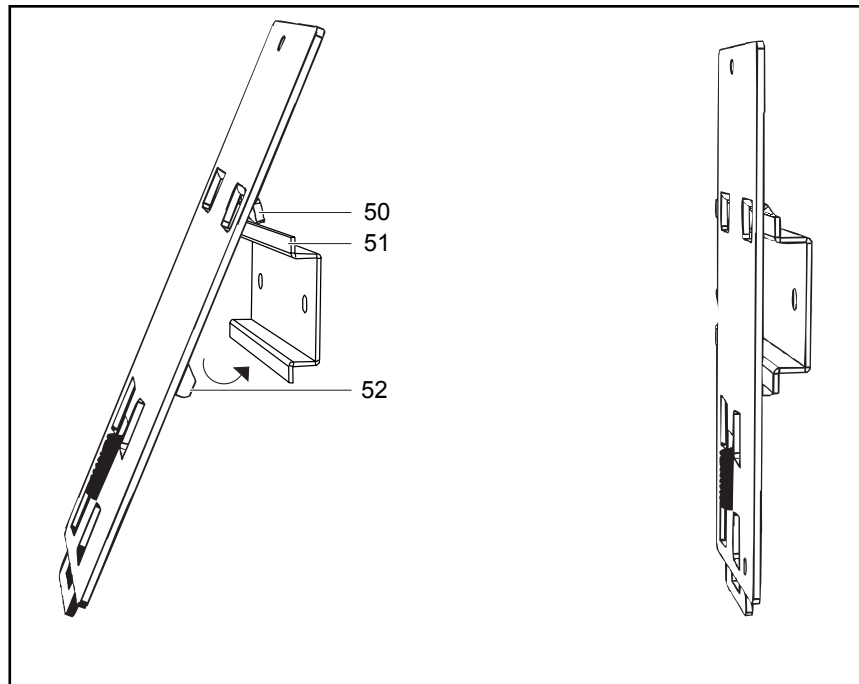

Fig. 5-3: Mounting the mounting rail adapter

5.6 Mounting on Profile Rail (only with Bosch Rexroth Accessories)

5.6.1 Fastening Profile Adapter on Module

In addition to the fastening using a mounting rail adapter, the S67-DO8-M8-2A module can be fastened to a profile rail using a profile adapter and slot nuts. The system has to support this fastening type. The slot nuts are not included in the scope of delivery.

Screw the S67-DO8-M8-2A module with the profile adapter using the M4 threaded screws provided as shown in the figure below.

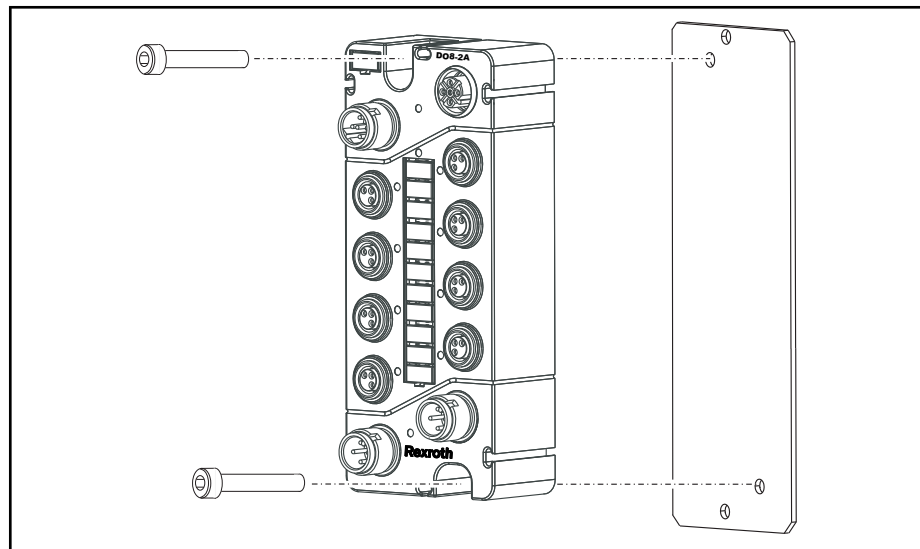

Fig. 5-4: Fastening a profile adapter

5.6.2 Fastening Module with Profile Adapter to Profile Rail

To fasten the S67-DO8-M8-2A module to a profile rail of the system, two slot nuts are required with one screw each (thread length has to match the profile).

1. Disconnect the power supply from those devices on which the S67-DO8-M8-2A module is to be mounted.
2. Insert the two screws into the holes above and beneath the fastened S67-DO8-M8-2A module on the profile adapter.
3. Fasten an appropriate slot nut on each of these screws.
4. Insert the profile adapter with the attached S67-DO8-M8-2A module into the profile rail of the system. Position the profile adapter and tighten the screws.

5.7 Replacing Labeling Fields

The module labeling plate and the labeling strip are provided upon delivery. Remove the protective cover when labeling the labeling strip. Proceed as follows:

1. Press the slot screwdriver (maximum slot width: 3 mm) into the small opening under the labeling strip cover (12) and lever it up.
2. Remove the labeling strip cover.
3. Label the labeling strip with a waterproof pen.
4. Insert the labeling strip cover again and press it firmly in place.

If the module labeling card (10) is to be replaced, proceed the steps previously described. New module labeling cards are available from Bosch Rexroth as accessories.

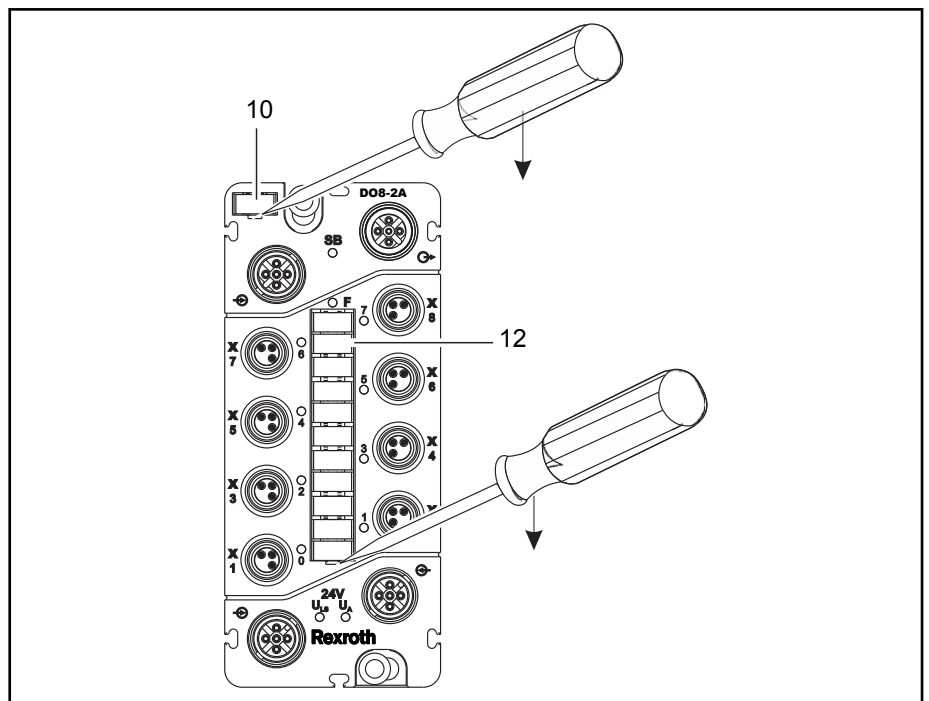

Fig. 5-5: Replacing labeling fields

Mounting Module

5.8 Mounting Spacer in Case of Compact Arrangement

Using the spacer, a sufficient mounting distance can be achieved when directly mounting the IndraControl S67 components. Gaps where dirt can accumulate are thus prevented. In addition, it is possible to optimize the cable routing of the actuators. Thus, two fastening lugs each for cable ties are located on the spacer.

1. Disconnect the power supply from those devices on which the S67-DO8-M8-2A module is to be mounted.
2. To prevent the IndraControl S67 components from falling out when mounted overhead, the spacer can only be moved to the intended openings of the S67-DO8-M8-2A module from below. To connect both components, place the S67-DO8-M8-2A module on the spacer or push the spacer from the bottom into the S67-DO8-M8-2A module.
3. Fasten the attached components on a flat surface by fastening the S67-DO8-M8-2A module to the grounded system frame or to another grounding point via the mounting holes using two M4 screws.

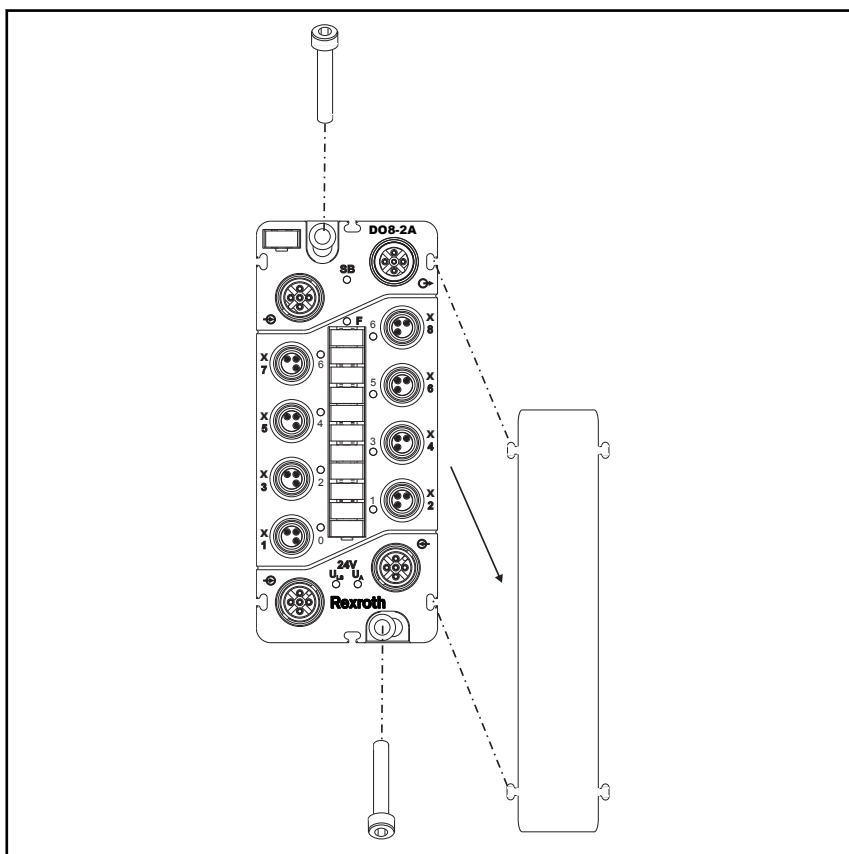

Fig. 5-6: Attaching spacer at module

4. When attaching further IndraControl S67 components, only one IndraControl S67 component connected with a spacer can be attached and screwed to the preceding component due to the mounting direction. The last IndraControl S67 component is fastened without a spacer.

Mounting Module

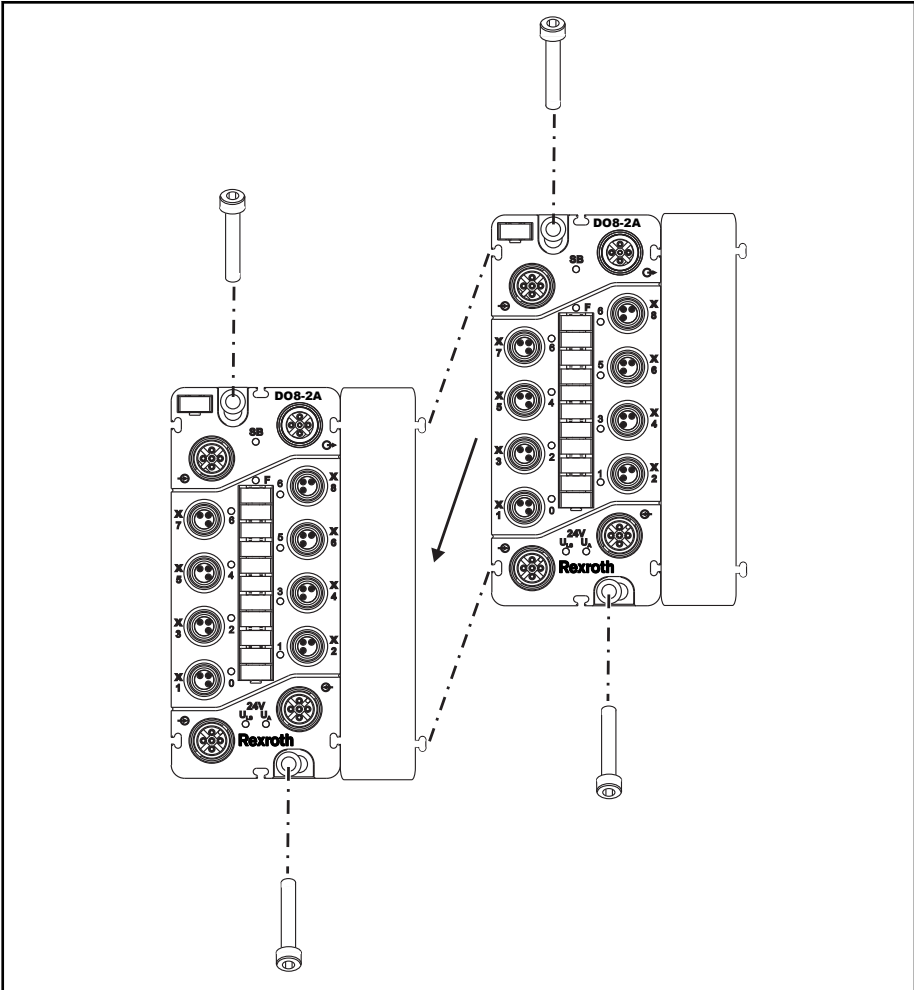

Fig. 5-7: Attaching another module with spacer

6 Connecting Data and Supply Cables

6.1 Notes

⚠ WARNING**Voltage!**

Operate IndraControl S67 components exclusively with DC 24 V PELV (protective extra-low voltage) or SELV (safety extra-low voltage) voltage sources. Non-compliance can result in electric shock.

NOTICE**Highest current carrying capacity of supply contacts is 4 A!**

Observe the maximum current carrying capacity per supply line (U_{LS} , U_A) as well as the total current consumption for all IndraControl S67 components. Both values must not exceed 4 A, as an increase in current causes the contacts to overheat and damages the IndraControl S67 components.

NOTICE**Open connections!**

If connections are not closed with protective caps, liquid or dirt can enter and thus destroy the S67-DO8-M8-2A module. Protect all connections that are not required with protective caps to comply with the degree of protection IP 67.

- The male connectors must be disconnected from the power supply before screws are tightened.
- Tighten the male connectors only by hand. Using mechanical tools can cause the threads to strip. In this case, the S67-DO8-M8-2A module has to be replaced

Tightening torques for male connectors are:

- Actuator connectors, M8: 0.4 – 0.5 Nm
- S-BUS and supply connections, M12: 0.6 Nm
- Check the exact positioning (coding) between plug and socket
- Use only ready-made Bosch Rexroth system cables to transmit the power supply and for the S-BUS. This achieves the specified characteristic values of technical data.
- Keep sufficient distance between all cables and electromagnetic interference sources to achieve a high noise immunity of the IndraControl S67 system against electromagnetic emissions.
- Note the minimum bending radius of Bosch Rexroth system cables (see [chapter 13 "Accessories" on page 59](#))
- When laying the cables, ensure not to lay cables in shear areas of moving machine parts
- Ensure the correct layout of the potential equalization
- Do not use drop stubs, as increased line reflections and signal distortions are caused! This worsens the transmission properties significantly.

Connecting Data and Supply Cables

6.2 Required Accessories

The Bosch Rexroth accessory components listed below are required to connect data and supply cables. The corresponding ordering numbers are listed in [chapter 13 "Accessories" on page 59](#).

- S-BUS terminator M12, degree of protection IP 67
- S-BUS and supply cables ready-made at both ends, IP 67
- Protective caps

6.3 Connecting S-BUS

The S-BUS is used for communication between a field bus coupler and the connected IndraControl S67 components.

Prerequisite:

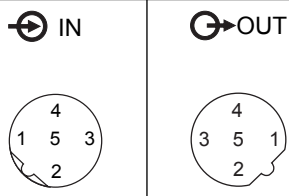
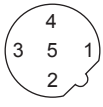

- A Bosch Rexroth S-BUS cable ready-made at both ends is available. It is required for an optimum signal transmission
- The S-BUS terminator is available. It is necessary for communication

The following table outlines the assignment of the S-BUS connections:

Connection		Contact	Description	
			IN	OUT
		1	RD+	TD+
		2	RD-	TD-
		3	TD-	RD-
		4	TD+	RD+
		5	0 V DC	
Connection thread	Shielded			

Tab. 6-1: S-BUS: Pin assignment

To connect the S-BUS cable to the field bus coupler and to the modules, proceed as follows:

1. Disconnect the power supply from those devices the S67-DO8-M8-2A module is mounted to.
2. Connect the S-BUS cable (S1) to the OUT connections  (3) of the field bus coupler and the IN connections  (1) of the S67-DO8-M8-2A module. For example, if two modules are connected to the field bus coupler, connect the S-BUS cables (S1, S2) to the associated IN and OUT connections as shown in the following figure.
3. Tighten the plugs and sockets using the knurled-head screws.
4. Attach the S-BUS terminator (T) to the last module and tighten the S-BUS terminator (as shown in the figure).

Connecting Data and Supply Cables

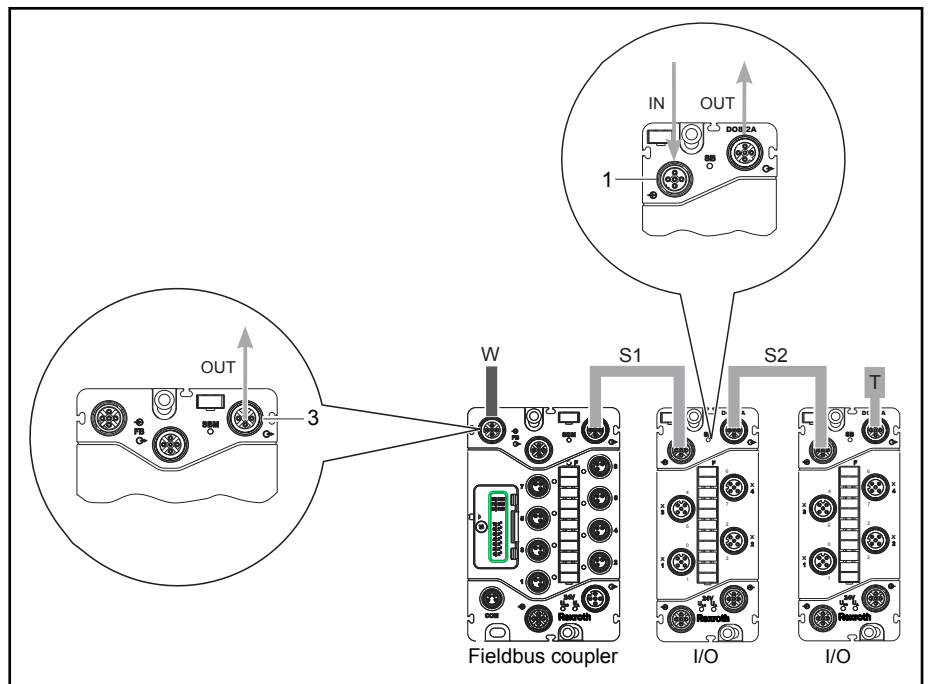

Fig. 6-1: S-BUS connected to field bus coupler and I/O modules

6.4 Connecting Supply Cables

The supply cable supplies the S67-DO8-M8-2A module.



Power supply cannot be transmitted!

The S67-DO8-M8-2A module with its increased output current of 2 A per channel does not allow any transmission of supply voltage, as it obtains two IN connections due to the increased power requirement. For other I/O modules, the supply voltage has to be fed in again.

Prerequisite:

A Bosch Rexroth supply cable ready-made at both ends is available (K2 and K3 in [fig. 6-3 "Supply cable connected to field bus coupler and I/O modules" on page 35](#)).

The following table outlines the assignment of the supply connections:

Connection		Contact	Description
		1	24 V DC U_{LS}
		2	24 V DC U_A
		3	0 V U_{LS}
		4	0 V U_A

Tab. 6-2: Supply connection: Pin assignment

Contact assignment of the supply cable ready-made on one end (view on socket):

Connecting Data and Supply Cables

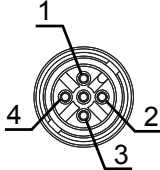
Connection	Contact	Description	Cable strand color
	1	24 V DC U_{LS}	Brown
	2	24 V DC U_A	White
	3	0 V U_{LS}	Blue
	4	0 V U_A	Black

Tab. 6-3: Supply cable ready-made on one end: Contact assignment

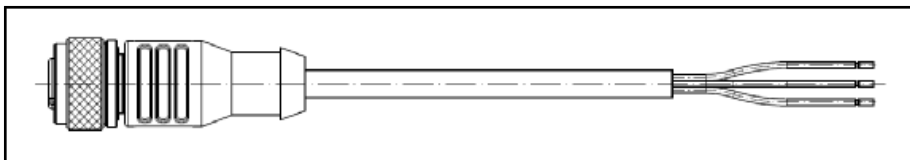

Fig. 6-2: Supply cable ready-made on one end

NOTICE

Highest current carrying capacity of supply contacts is 4 A!

Observe the maximum current carrying capacity per supply line (U_{LS} , U_A) as well as the total current consumption for all IndraControl S67 components. Both values must not exceed 4 A, as an increase in current causes the contacts to overheat and damages the IndraControl S67 components.

To connect the supply cable to the field bus coupler and to the modules, proceed as follows:

1. Disconnect the power supply from those devices the S67-DO8-M8-2A module is mounted to.
2. For example, if one I/O module and the S67-DO8-M8-2A module are connected to the field bus coupler, connect the cable K1 with the associate IN and OUT connections to the I/O module for the supply voltage transmission as shown in the following figure.
3. For the S67-DO8-M8-2A module, feed in the supply voltages again using the two IN connections (K2, K3) as shown in the following figure.
4. Tighten the plugs and sockets using the knurled-head screws.
5. Screw a protective cap on all unused connections to comply with the degree of protection IP 67.

For information on the supply voltage cable connection (K0) to the IN input  (6) of a field bus coupler, refer to the corresponding application descriptions of the field bus couplers.

Connecting Data and Supply Cables

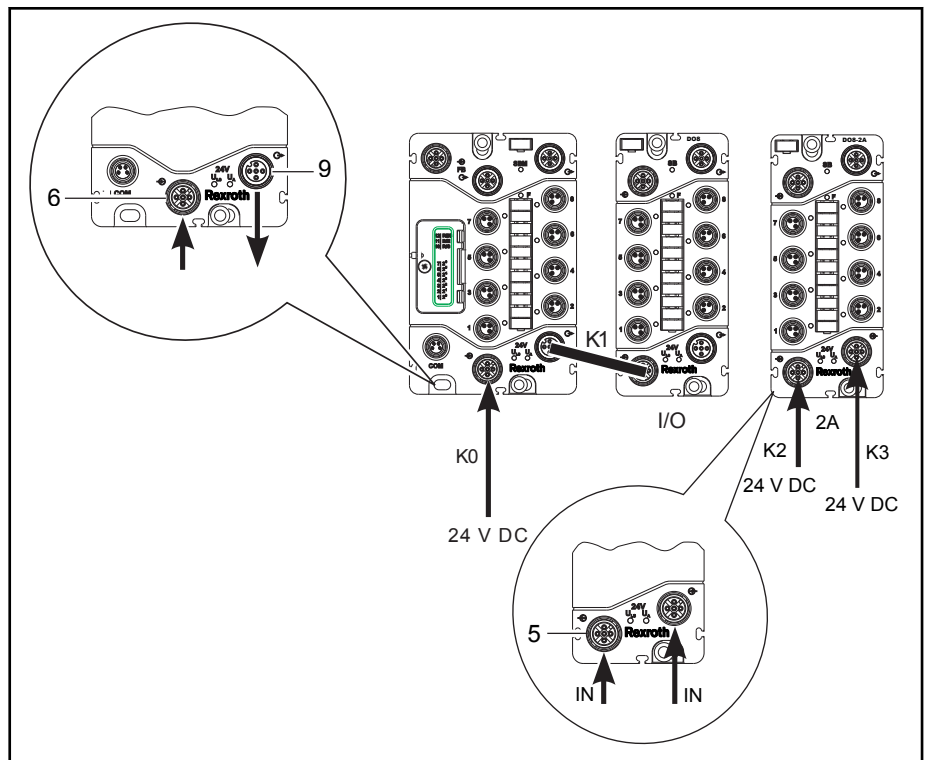

Fig. 6-3: Supply cable connected to field bus coupler and I/O modules

6.5 Connecting Actuator Cables

The actuator cables supply the connected actuators and transfer the actuator signals.

If ready-made cables are not used, ensure that an M8 connector with the degree of protection IP 67 is connected to the cables. The following table outlines the assignment of the actuator connections:

Connection		Contact assignment
IN X1, X3, X5, X7	IN X2, X4, X6, X8	1: 24 V U_A 3: 0 V U_A 4: Output

Tab. 6-4: Digital outputs: Pin assignment

NOTICE

Highest current carrying capacity of supply contacts is 4 A!

Ensure that the actuators are supplied from the U_A supply line. The current consumption of the actuator has to be considered when determining the current power demand for the V_A supply line.

To connect the actuators to the digital outputs (X1 – X8), proceed as follows:

1. Disconnect the power supply from those devices the S67-DO8-M8-2A module is mounted to.

Connecting Data and Supply Cables

2. Connect the plug of the actuator cable with the socket of a digital output (3) of the S67-DO8-M8-2A module and tighten the plug using a knurled-head screw.
3. Screw a protective cap on all unused connections to comply with the degree of protection IP 67.

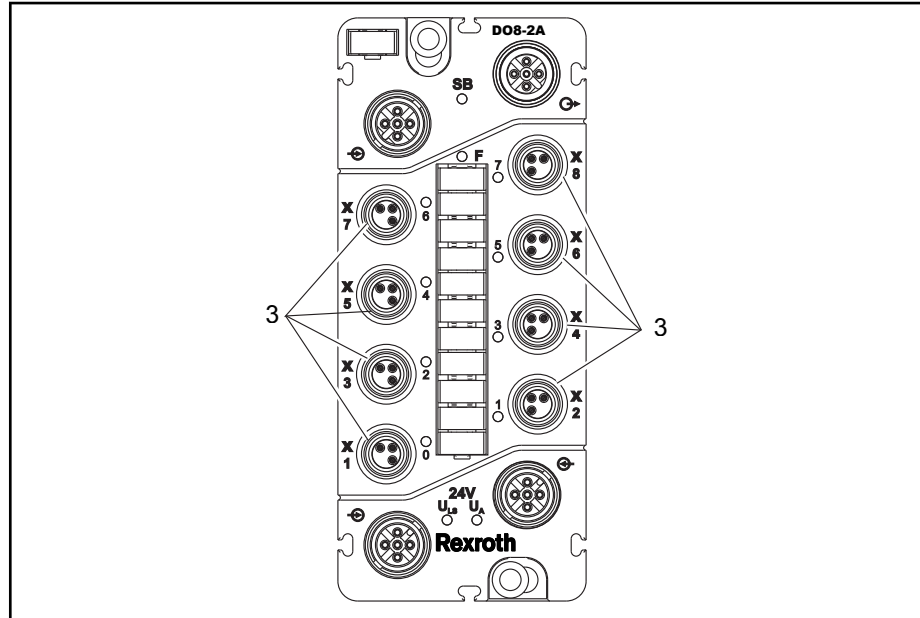

Fig. 6-4: Digital outputs

7 Commissioning

7.1 General Information

NOTICE**Open connections!**

If connections are not closed with protective caps, liquid or dirt can enter and thus destroy the S67-DO8-M8-2A module. Protect all connections that are not required with protective caps to comply with protection class IP 67.

Before commissioning the IndraControl 767 station, check the following:

- a field bus coupler of the IndraControl S67 series¹⁾ and the S67-DO8-M8-2A module are mounted properly
- all required supply, sensor or actuator and S-BUS cables as well as the S-BUS connection are screwed tightly at the provided connections (see [chapter 6 "Connecting Data and Supply Cables" on page 31](#))
- an appropriate potential equalization was executed at the system
- the shielding was executed correctly

¹⁾ Refer to the application descriptions of the field bus couplers (IndraControl S67)

8 Process Images

8.1 General Information

The process images of the module provided in the following chapters describe the data position on the S-BUS. For information on how S-BUS process images are realized on the respective field bus process images, refer to the application descriptions of the field bus couplers.

The process image is divided into two sections: One section for output data and one section for input data. The process image can include process data with or without diagnostic information depending on whether the transmission of the synchronous¹⁾ diagnostic information is enabled. This is only possible with a field bus coupler supporting the synchronous diagnostic function (e.g. S67-PB-BK-DI8-M8). For detailed information on the activation of diagnostic information transfer, refer to the chapter "Device Description File" in the application description of the field bus couplers.



Synchronous diagnostics is disabled in the module in its delivery state.

For detailed information, refer to [chapter 9 "Parameterization" on page 43](#).



The diagnostics of the outputs "Short-circuit/overload actuator" and "disconnection" (wire breakage) depend on the switching state of the outputs. If the output is active, short-circuit or overload can be diagnosed, but no disconnection. If the output is inactive, only a disconnection can be diagnosed.

8.2 Output Data

Output data is sent from the field bus coupler to the S67-DO8-M8-2A module. The process image of the S67-DO8-M8-2A module can include process data with or without diagnostic acknowledgement. If a synchronous diagnostic acknowledgement is parameterized, the process image size is 5 bytes. Otherwise, only process data of 1 byte exists.

Process data and diagnostic acknowledgement are structured as follows:

¹⁾ *Synchronous diagnostic information specifies the cyclic diagnostic information transfer in the process image. By default, the cyclic diagnostic information transfer is disabled in the module.*

Process Images

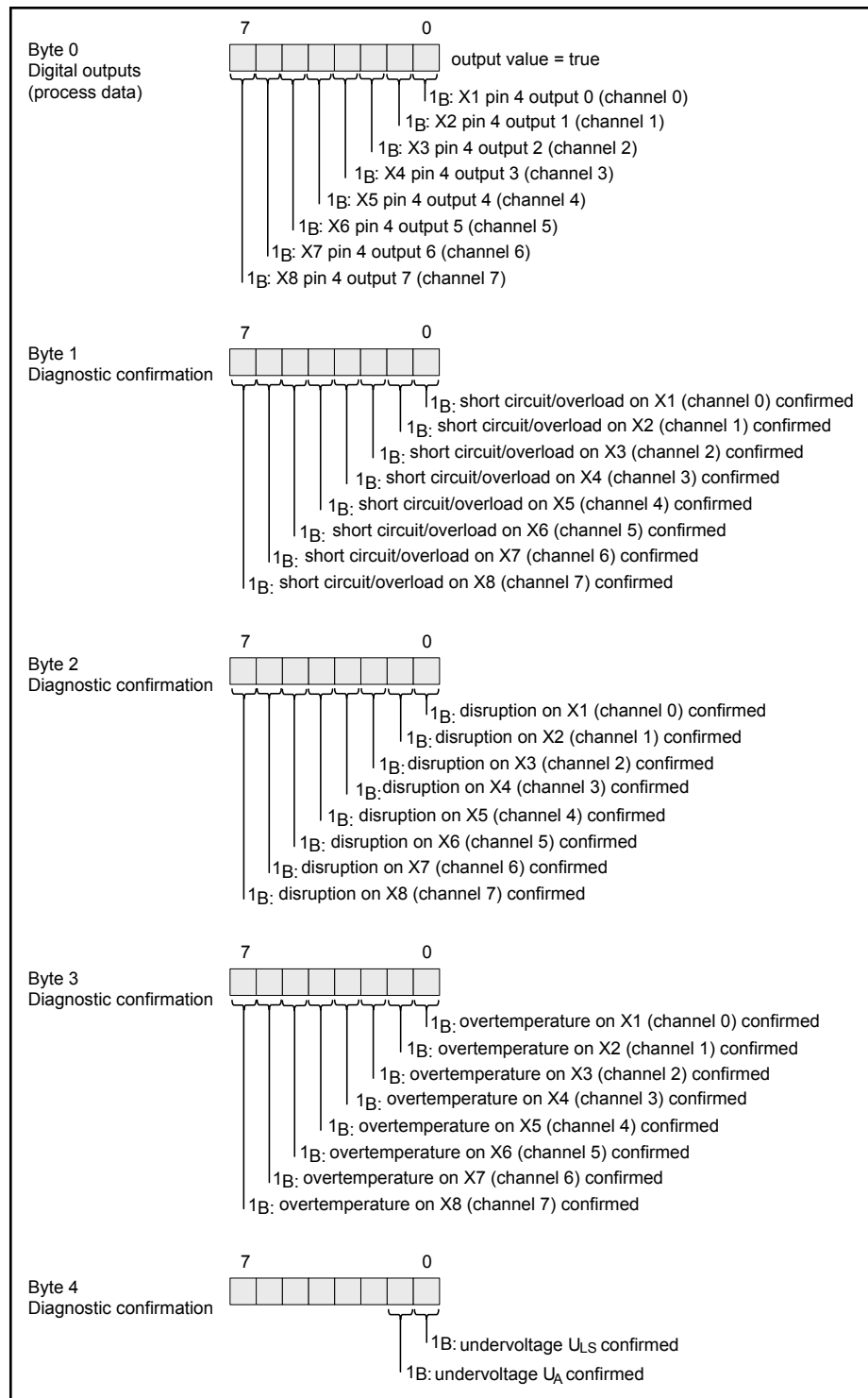

Fig. 8-1: Process image of output data

8.3 Input Data

The process image size for the input data (diagnostic messages) sent from the S67-DO8-M8-2A module to the field bus coupler, is 4 bytes if a synchronous diagnostics is parameterized. Otherwise, this input data does not exist.

The bytes are structured as follows:

Process Images

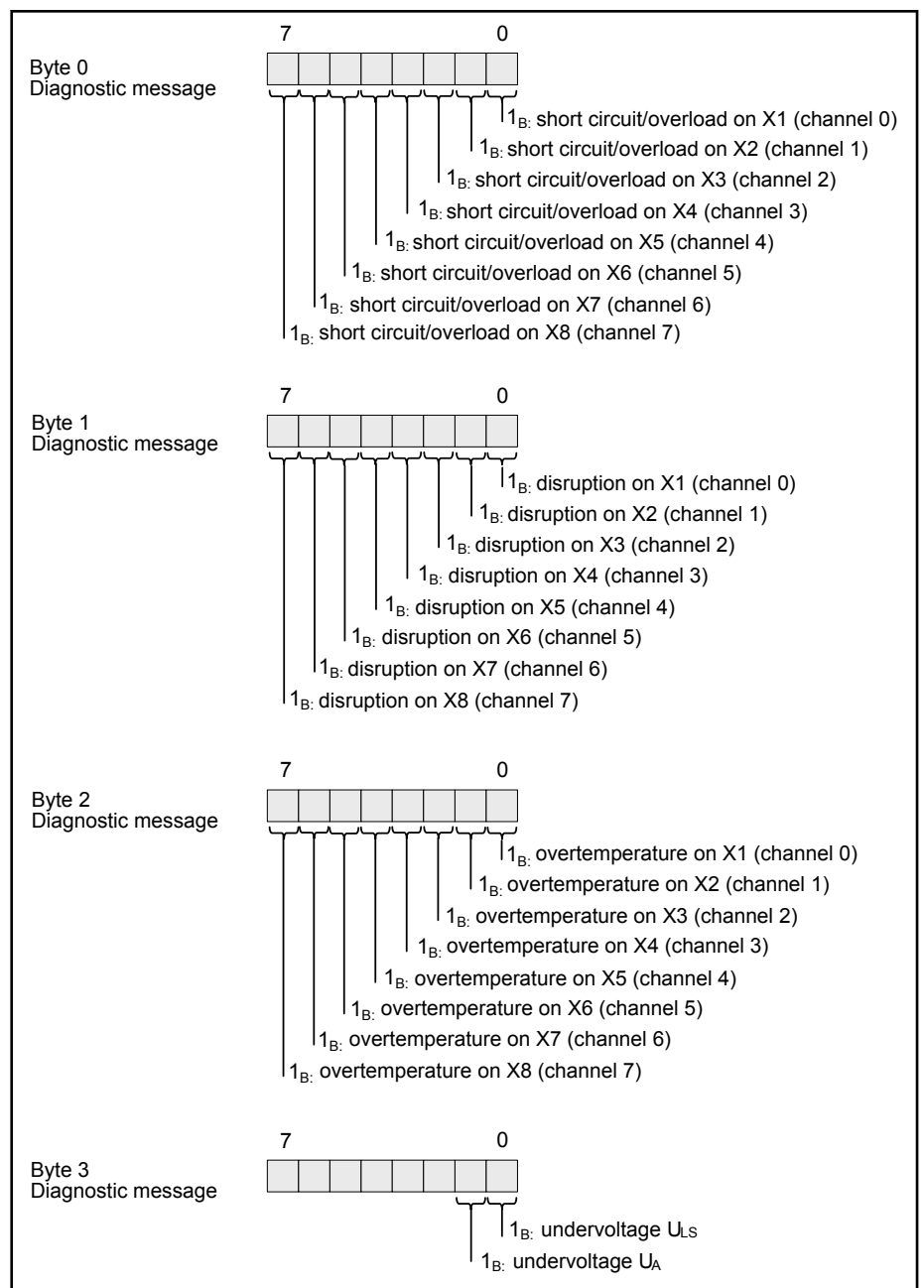

Fig. 8-2: Process image of input data



Generally, both diagnostic messages "Short circuit/Overload" and "Excess temperature" are reported simultaneously!

9 Parameterization

9.1 General Information

According to the field bus type, only certain parameters are available for parameterization. For further information, refer to respective field bus coupler manuals.

⚠ WARNING

Changing parameters!

When parameters are changed incorrectly, machine components can be in a dangerous state and endanger personnel and machines. Before changing the parameters, ensure that the machine components are in a safe and defined state and switch off the parent control. Ensure before commissioning that no personnel is in the danger zone of the machine components.

When parameterizing with IndraWorks, set the operating settings of the S67-DO8-M8-2A module, e.g. the response in case of error and the release of diagnostic messages.

The operating settings are transmitted via parameter telegram to the S67-DO8-M8-2A module operated at the S-BUS.

The S67-DO8-M8-2A module is parameterized in IndraWorks. Double-click on the S67-DO8-M8-2A module in the Project Explorer to open the parameterization interface in the workspace. The S67-DO8-M8-2A module is parameterized offline. The offline mode enables the parameterization of a not yet existing S67-DO8-M8-2A module. The set parameters are first saved in the project. The parameter data is applied during the PLC program download.

9.2 Diagnostic Overview

The S67-DO8-M8-2A module supports module-comprehensive (global) and channel-related diagnostics. The transmission of diagnostics can be enabled and disabled. If a diagnostics is disabled, the display response of the LED(s) signaling the respective diagnostics, changes. For further information, refer to [chapter 10 "Diagnostics via LED Signals" on page 47](#).

The diagnostic messages of the S67-DO8-M8-2A module are specified according to the following tables:

Parameterization

Global diagnostics	Description
Undervoltage U_{LS}	<p>⚠ WARNING</p> <p>Disabling the outputs. In case of an undervoltage of U_A and/or U_{LS}, the module outputs are disabled. Machine components can be set to a dangerous state and endanger personnel as well as machine.</p> <p>If there is an undervoltage at the module of the logic and sensor supply ($U_{LS} < 18\text{ V}$), the outputs are disabled and a diagnostics is sent to the field bus coupler. The F-LED of the module is lit</p>
Undervoltage U_A	<p>⚠ WARNING</p> <p>Disabling the outputs. In case of an undervoltage of U_A and/or U_{LS}, the module outputs are disabled. Machine components can be set to a dangerous state and endanger personnel as well as machine.</p> <p>If there is an undervoltage of the actuator supply ($U_A < 18\text{ V}$) at the module, the outputs are disabled and a diagnostics is sent to the field bus coupler. The F-LED of the module is lit</p>

Tab. 9-1: Global diagnostics of the module

Channel diagnostics	Description
Short circuit/actuator overload	The module detected a short circuit or overload at the corresponding channel (1 – 8) (only active in case of an active actuator output)
Actuator interruption	The module detected an interruption or overload at the corresponding channel (1 – 8) (only active in case of an active actuator output)
Overtemperature	The module detected overtemperature at the corresponding channel (1 – 8) (only active in case of an active actuator output)

Tab. 9-2: Channel diagnostics of the module



If the S-BUS is interrupted, the S67-DO8-M8-2A module automatically goes into the STOP state. The module outputs are disabled.

9.3 Output Parameters

An overview on the parameters to be set for the digital outputs is given in the following table.



Bold parameters are default values.

Parameter	Description
Diagnostics	The channel-related diagnostics can be enabled/disabled (for more information, refer to tab. 9-2 "Channel diagnostics of the module" on page 44): <ul style="list-style-type: none"> - Lock^① - Unlock
Substitute value strategy	The substitute value strategy outputs the substitute value or the last output value (e.g. a field bus is interrupted). The following options are available: <ul style="list-style-type: none"> - Add substitute value^① - Retain last value^②
Substitute value	Enter the substitute value used in case of error. In case of error (e.g. field bus interruption), this value is used for the substitute value strategy "Add substitute value". <ul style="list-style-type: none"> - 0^① - 1

① Delivery state

② The last value is a value reported at the contact before the interference. This can be a process value for example

Tab. 9-3: Overview on adjustable parameters for the digital outputs

9.4 Global Settings for Field Supply

In case of a short circuit, the field supply is switched off for 1,000 ms. The field supply is subsequently switched on again. If the short circuit remains, the procedure is repeated.

9.5 Automatic Storage of System Parameters

Some field bus couplers provide the "System Parameter Handling" function. This function detects configuration changes at the IndraControl S67 node and is used for the automatic module parameterization. If a module is to be replaced due to a defect, the new module does not have to be parameterized. The stored parameters are automatically applied to the replaced module.

9.6 Firmware Update

During a firmware update of the S67-DO8-M8-2A module, the stored module parameters can be overwritten. Thus, check the parameterization after a firmware update.



The firmware can only be updated by the Bosch Rexroth Service.

10 Diagnostics via LED Signals

10.1 General Information

For on-site diagnostics, the S67-DO8-M8-2A module has different LEDs indicating the operating states of module and S-BUS.

10.2 Operating Messages of the Module

The following table lists the operating messages indicated via LEDs. Information on remedies of certain causes is also provided.

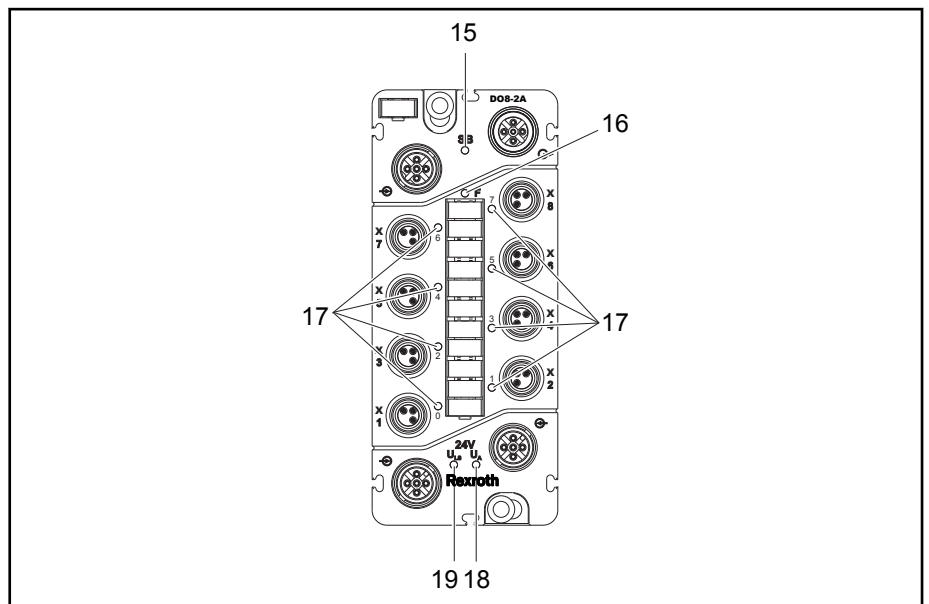

Fig. 10-1: LEDs indicating operating messages

Diagnostics via LED Signals

Position	LED	Color/status	Cause	Remedy/information
15	SB	Off	Undervoltage U_{LS} not present	Check supply voltage
		Red, flashing, 4 Hz	S-BUS error at module	Check whether the S-BUS cable is connected. Check the S-BUS cable for damages. Check whether the firmware of the field bus coupler and the module are compatible
		Red, flashing, 1 or 2 Hz	The module is reset via the field bus coupler	If the flashing frequency is 1 Hz, contact the Bosch Rexroth service
		Green	Data is exchanged. Process data values are valid. The module is in RUN state	–
		Green and orange, flashing, 1 Hz	The set substitute value is applied to the module	Can be set by the field bus coupler if field bus is missing. Check the field bus connection as well as the status of the parent control
		Orange, flashing, 2 Hz	Module detected S-BUS	–
		Orange and green, flashing, 4 Hz	Detection of last module in IndraControl S67 node is executed	Check S-BUS terminator or wiring
		Orange, flashing, 1 Hz	Field bus coupler addresses module in IndraControl S67 node	–
		Orange and green, flashing, 2 Hz	S-BUS parameters applied by field bus coupler	–
		Orange	Firmware update	All IndraControl S67 components are updated by the field bus coupler within the node
15	SB	Green, flashing 1 Hz	Module in HOLD state	Initiated by field bus coupler. Last values output at module are retained
		Green, flashing 2 Hz	The module is in STOP state	Initiated by field bus coupler. "0" returned as output value

Tab. 10-1: Operating messages 1

Diagnostics via LED Signals

Position	LED	Color/status	Cause	Remedy/information
16	F	Red	At least one global diagnostic message occurred at module	Check supply voltages U_{LS} and U_A of upstream IndraControl S67 components
17	I/O	Yellow	Output signal present	–
		Red	Error at output	Check actuator connection for short circuit, overload and wire breakage. If the output is active, short-circuit or overload can be diagnosed, but no disconnection. If the output is inactive, only a disconnection can be diagnosed (wire breakage)

Tab. 10-2: Operating messages 2

Position	LED	Color/status	Cause	Remedy/information
18	U_A	Green	Actuator supply U_A present	–
		Off	Actuator supply U_A not present	Connect supply voltage and check voltage level if required
19	U_{LS}	Green	Logic and sensor supply U_{LS} present	–
		Off	Logic and sensor supply U_{LS} not present	Connect supply voltage and check voltage level if required

Tab. 10-3: Operating messages 3

11 Maintenance and Service

11.1 General Information

This chapter provides information on maintenance and service.

11.2 Replacing Module

11.2.1 General Information

To replace a S67-DO8-M8-2A module if a version changes for example, proceed as described in the following chapters.

11.2.2 Disconnecting Wiring

Before removing the male connectors, clean the S67-DO8-M8-2A module to ensure that no dirt comes in contact with the connections. Otherwise, the contacts can be damaged.

To unplug the cables, proceed as follows:

1. Disconnect the power supply from those devices the S67-DO8-M8-2A module is mounted to.

⚠ CAUTION

Hot connector sockets!

Even when taking derating into account, high surface temperatures on the metallic connector sockets and at the housing can arise during operation. If the IndraControl S67 component was in operation, allow it to cool off before touching it.

2. Unscrew all connections and remove the cables.

11.2.3 Removing Module from System

To remove the S67-DO8-M8-2A module from the system, proceed as follows:

1. Disconnect the power supply from those devices the S67-DO8-M8-2A module is mounted to.
2. Release the S67-DO8-M8-2A module from the system by unscrewing the M4 screws.

11.2.4 Removing Module from Mounting Rail

For a clear figure, the mounting rail adapter in the figure below (B, C) is shown without the S67-DO8-M8-2A module.

If the S67-DO8-M8-2A module is mounted on a mounting rail, proceed with the removal as follows:

1. Disconnect the power supply from those devices the S67-DO8-M8-2A module is mounted to.
2. To remove the S67-DO8-M8-2A module, press down the release lug of the mounting rail adapter using a slotted screwdriver (B) and remove the mounting rail adapter from the rail (C).

Maintenance and Service

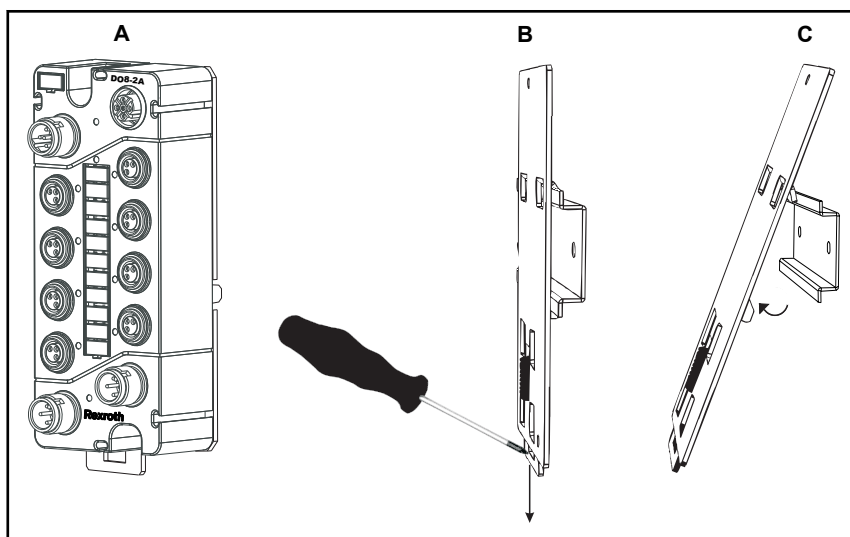

Fig. 11-1: Removing module with mounting rail adapter from mounting rail

11.2.5 Removing Module from Profile Adapter

If the S67-DO8-M8-2A module is mounted on a profile adapter, proceed with the removal as follows:

1. Disconnect the power supply from the device the S67-DO8-M8-2A module is mounted to before removal.
2. Unscrew the screws the nuts are fastened on and remove the S67-DO8-M8-2A module from the profile rail of the system.
3. Unscrew the screws that connect the S67-DO8-M8-2A module with the profile adapter.

11.2.6 Connecting Module

To connect the new S67-DO8-M8-2A module, proceed as described in the following chapters:

- [chapter 5 "Mounting Module" on page 23](#)
- [chapter 6 "Connecting Data and Supply Cables" on page 31](#)
- [chapter 7 "Commissioning" on page 37](#)

Depending on the type of field bus coupler used, the parameters of the previous S67-DO8-M8-2A module are transferred to the new module if necessary (see also [chapter 9.5 "Automatic Storage of System Parameters" on page 45](#)).

11.3 Disposal

Do not dispose the IndraControl S67 components with the household waste. Comply with the regulations. You can also contact a certified waste disposal company.

12 Using Feedback-Free Module in Safety Applications

12.1 General Information

Due to its feedback-free feature, this module is suitable for passive use in safety circuits.

If the field-sided supply is switched off via a safety control device, the safety function of the module responds passively to the safety function. If the feedback-free module is used correctly in a safety application, the "SIL" or the "Performance Level" reached due to the switching as well as the category are not affected. Refer to the following information and connection diagrams.

The absence of feedback of the digital output modules is supported starting from the following technical module index:

Parts number	Type code	Technical index
R911171789	S67-DO8-M8	AC
R911171790	S67-DO8-M12	AD
R911171791	S67-DO8-M8-2A	AC
R911171792	S67-DO8-M12-2A	AC
R911173105	S67-DO8-M12×8	AA
R911172409	S67-DIO8-M8	AA
R911172900	S67-DIO8-M12×8	AA

Tab. 12-1: Technical index from which the digital output modules support the absence of feedback

The technical index is specified on the module type plate (refer to the chapter "Device Description", subchapter "Type Plate").

12.2 Important Information

NOTICE

Only for SELV/PELV power supply units!

Only a power supply unit specified for an "Extra-low-voltage with safe electrical separation" (SELV/PELV) can be used for the 24 V supply voltage provision.

NOTICE

Prevent short circuits to external voltages at digital outputs!

The short circuit from a digital output to external voltages (e.g. 24 V field supply voltages) results in a reverse feeding in of the field supply and thus the loss of the safety function. To eliminate potential errors, connection lines between the outputs of feedback-free modules and actuators are wired with protection acc. to EN 60204-1 or EN ISO 13849-2.

Using Feedback-Free Module in Safety Applications

NOTICE**Short circuits between two digital outputs!**

A short circuit between two digital outputs of feedback-free modules is not detected by the safety control device. The two-channel switch-off of feedback-free modules is not a safety function. It merely serves to functionally switch off the actuators.

12.3 General Measures and Requirements for the Module Supply Concept

NOTICE**Prevent conductive dirt!**

Prevent conductive dirt in the sockets of the supply voltage connections for the voltages U_A and U_{LS} by appropriate measures. Before establishing a connection, verify that the contact areas are free from dirt and foreign particles. Only use clean tools and materials when handling modules.

NOTICE**Tighten connectors with torque!**

Tighten the connectors with a torque of 0.6 Nm to reach the degree of protection IP 67. Otherwise, safe switching-off of the I/O module by a safety control device cannot be ensured in case of penetrating dirt.

NOTICE**Comply with the specification of the connection lines!**

The values in the specification of the connection lines regarding the environmental properties and the mechanical load must never be exceeded.

⚠ WARNING**Use a safety control device with diagnostic functions!**

The safety control device has to be able to detect if an external voltage is fed in (e.g. due to a line short circuit) causing the loss of the safety function.

NOTICE**Prevent fanning out of strands when connecting wire ends to connectors!**

If no ready-made Bosch Rexroth cables are used, fanning out strands when connecting wire ends to connectors has to be prevented. Sporadically, a short circuit in the connectors can result in the loss of the safety function. If required, check the wire insulation, e.g. by using a high voltage test.

Using Feedback-Free Module in Safety Applications

NOTICE Protect the supply voltages with an external fuse!

The supply voltages U_A and U_{LS} have to be protected by a suitable external fuse to ensure that the current flow is interrupted if an error occurs. U_A and U_{LS} can be protected with a fuse cut-out each acc. to EN 60127-2 or with an electronic fuse each. Fuse cut-outs have to comply with the following technical specifications acc. to EN 60127-2:

- G-fuse link
- Rated current 4 A
- Slow-blow
- Current pulse insensitive
- Large or increased switch-off capacity
- Rated voltage $\geq 60V$ DC
- Time-current characteristics: 275 % of the nominal current, corresponding to 11 A, maximum 80 s

12.4 Measures and Requirements for Shielded Module Voltage Supply

NOTICE Shielded version of U_A and $0V U_A$ in connection lines required in case of unprotected wiring!

To exclude a short circuit of the voltage supply U_A with an external voltage, the wires U_A and $0V U_A$ in the connection lines have to be shielded acc. to EN 60204-1 or EN ISO 13849-2. The shield requires a coverage of 85 % and has to be defined and reliably connected to the male connector.

NOTICE Apply ground shield or use insulation monitoring!

Connect the ground shield of the connection lines to the functional earth connection FE of the feedback-free modules to the $0V U_{LS}$ and $0V U_A$ lines. An insulation monitoring can also be used acc. to EN 61557. Refer to the following figures:

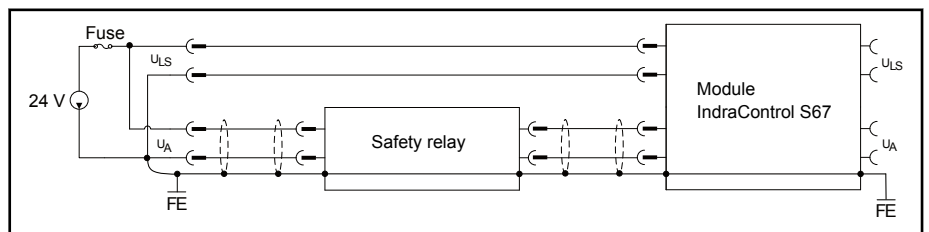

Fig. 12-1: Connection diagram for common voltage supply

Using Feedback-Free Module in Safety Applications

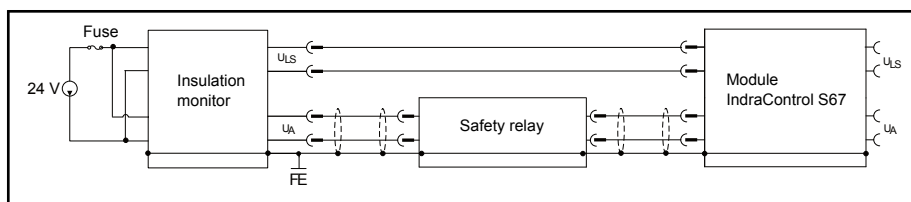

Fig. 12-2: Connection diagram for common voltage supply with insulation monitoring

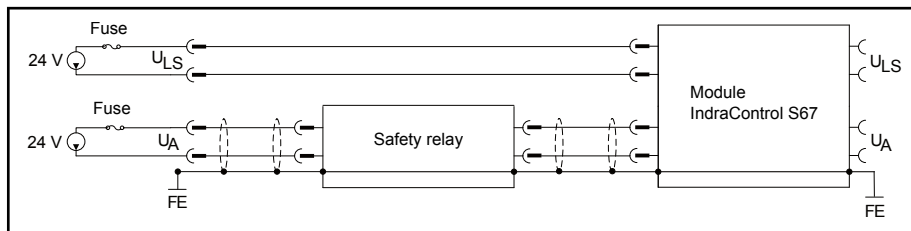

Fig. 12-3: Connection diagram for isolated voltage supply

12.5 Measures and Requirements for Unshielded Module Voltage Supply

NOTICE

Measures when using connection lines without shielding!

When using unshielded connection lines for the supply of feedback-free modules, it is required to wire the connection lines in a cable channel, an armored conduit or a protected installation space acc. to EN 60204-1 or EN ISO 13849-2. The measures have to ensure that no errors (short circuit between any conductors) can occur acc. to EN 60204-1 or EN ISO 13849-2. The error exclusion has to apply to the voltage supplies U_A and the external voltages (e.g. U_{LS}). Also check the wiring in the exit area of the protection measure (e.g. exit area of the armored conduit/cable channel).

12.6 Connecting Module to Safety Control Devices

12.6.1 General Structure of a Potential Group

When using feedback-free modules in safety applications, the feedback-free modules of the safety control device have to be grouped in a potential group. The voltage supply U_A of the feedback-free module can only be connected to the digital output of an appropriate safety control device (24 V).

Using Feedback-Free Module in Safety Applications

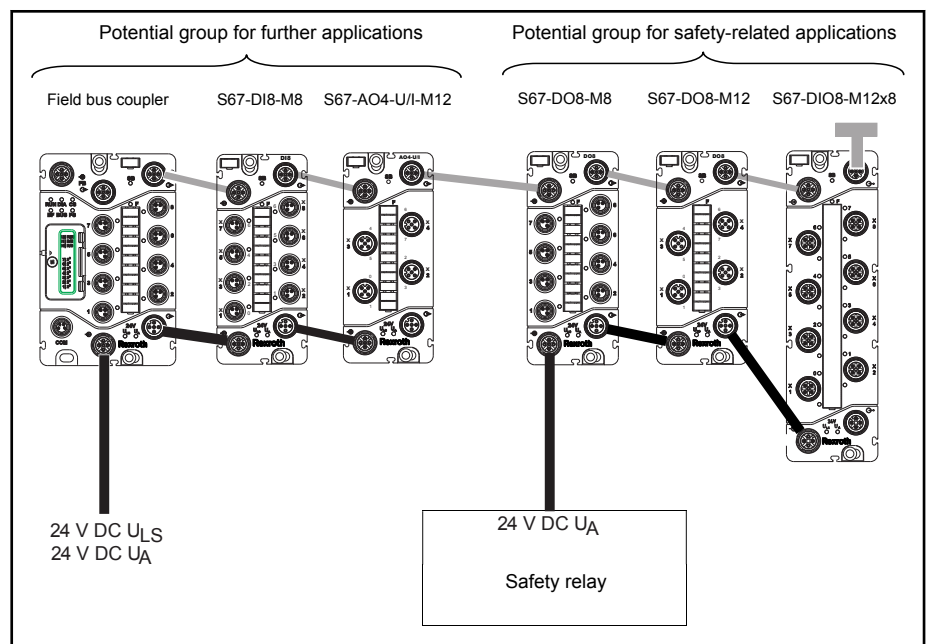

Fig. 12-4: Exemplary structure of potential groups

12.6.2 Connection Examples

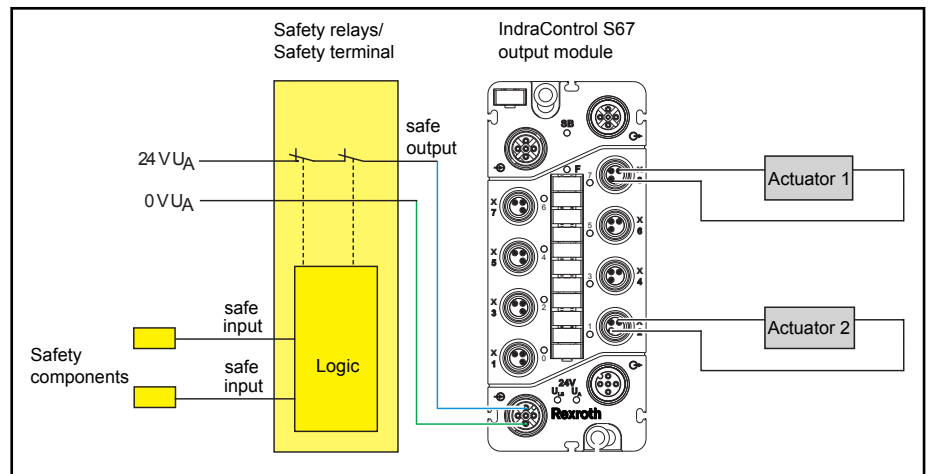

Fig. 12-5: Single-pole switch-off of the voltage supply of all digital outputs

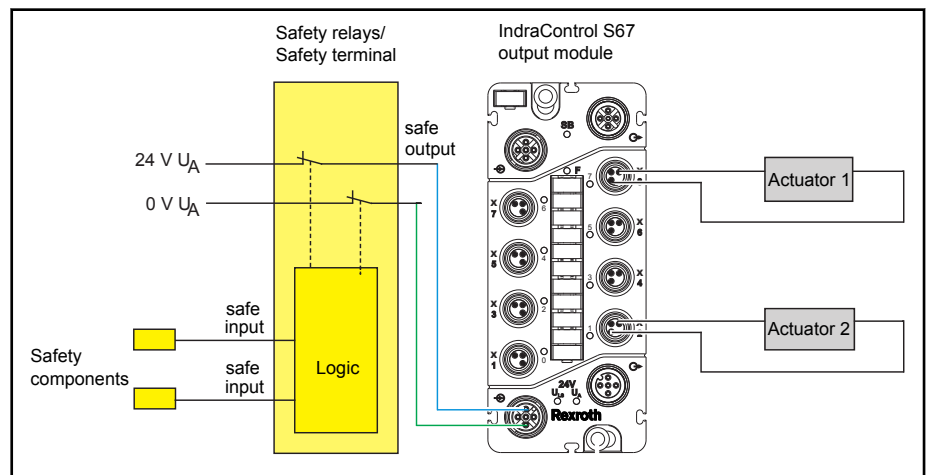

Fig. 12-6: Two-pole switch-off of the voltage supply of all digital outputs

13 Accessories

13.1 General information

The most important IndraControl S67 accessory components to commission the IndraControl S67-DO8-M8-2A module are listed.

13.2 Assembled S-BUS Cables

Cable carrier compatibility:

- RKB0041: No cable carrier compatibility specified
- RKB0049: Cable carrier-compatible

Bending radii and bending cycles:

RKB0041:

- Smallest bending radius, fix installation: At least 5 x cable diameter
- Number of bending cycles: 3 millions

RKB0049:

- Smallest bending radius, fix installation: At least 5 x cable diameter
- Smallest bending radius, flexible use: At least 5 x cable diameter
- Number of bending cycles: 3 millions

Tensile load:

- Cable, tensile load: 60 N
- Connector, tensile load: 60 N

Temperature ranges:

RKB0041:

- Continuous operation temperature, idle state: -20 °C ... +60 °C
- Storage/transport: 0 °C ... +50 °C
- Mounting: 0 °C ... +50 °C

RKB0049:

- Continuous operation temperature, idle state: -30 °C ... +85 °C
- Continuous operation temperature, moving state: 0 °C ... +50 °C
- Storage/transport: 0 °C ... +50 °C
- Mounting: 0 °C ... +50 °C



For the connector assignment of the S-BUS connection as well as the notes on the S-BUS cable connection, refer to the chapter "Connecting Data and Supply Cables".

System bus cable, M12 axial socket, M12 axial socket

Ordering code	Parts number	Length
RKB0049/000,2	R911347534	0.2 m
RKB0049/000,5	R911347535	0.5 m
RKB0049/001,0	R911347474	1.0 m
RKB0049/002,0	R911347537	2.0 m
RKB0049/003,0	R911347475	3.0 m

Accessories

Ordering code	Parts number	Length
RKB0049/004,0	R911347538	4.0 m
RKB0049/004,5	R911347539	4.5 m
RKB0049/005,0	R911347476	5.0 m
RKB0049/005,5	R911347540	5.5 m
RKB0049/006,0	R911347541	6.0 m
RKB0049/006,5	R911347542	6.5 m
RKB0049/007,0	R911347543	7.0 m
RKB0049/007,5	R911347477	7.5 m
RKB0049/010,0	R911347478	10.0 m
RKB0049/010,5	R911347544	10.5 m
RKB0049/012,0	R911347545	12.0 m
RKB0049/014,0	R911347546	14.0 m
RKB0049/015,0	R911347479	15.0 m
RKB0049/016,5	R911347547	16.5 m
RKB0049/017,0	R911347548	17.0 m
RKB0049/018,0	R911347549	18.0 m
RKB0049/019,0	R911347550	19.0 m
RKB0049/020,0	R911347480	20.0 m
RKB0049/020,5	R911347551	20.5 m
RKB0049/021,0	R911347552	21.0 m
RKB0049/023,0	R911347553	23.0 m
RKB0049/025,0	R911347481	25.0 m
RKB0046/000,0	R911172581	Variable length

Tab. 13-1: S-BUS cable, ready-made on both sides

Ordering code	Parts number	Length
RKB0041/000,2	R911171990	0.2 m
RKB0041/000,3	R911171991	0.3 m
RKB0041/000,5	R911171992	0.5 m
RKB0041/001,0	R911171993	1.0 m
RKB0041/002,0	R911171994	2.0 m
RKB0041/005,0	R911171995	5.0 m
RKB0041/010,0	R911171996	10.0 m
RKB0041/000,0	R911172579	Variable length

Tab. 13-2: S-BUS cable, ready-made on both sides

S-BUS terminator, axial plug

Ordering code	Parts number
RBS0020/CNN	R911171998

Tab. 13-3: S-BUS terminator

13.3 Ready-Made Supply Cables

Cable carrier compatibility:

- RKB0046: Cable carrier-compatible
- RKB0047: Cable carrier-compatible

Bending radii and bending cycles:

RKB0046:

- Smallest bending radius, flexible use: At least 10 x cable diameter
- Number of bending cycles: 5 millions

RKB0047:

- Smallest bending radius, flexible use: At least 10 x cable diameter
- Number of bending cycles: 3 millions

Tensile load:

- Cable, tensile load: 45 N
- Connector, tensile load: 45 N

Temperature ranges:

RKB0046:

- Continuous operation temperature, idle state: -30 °C ... +80 °C
- Continuous operation temperature, moving state: -30 °C ... +80 °C
- Storage/transport: -5 °C ... +80 °C
- Mounting: -5 °C ... +80 °C

RKB0047:

- Continuous operation temperature, idle state: -30 °C ... +80 °C
- Continuous operation temperature, moving state: -30 °C ... +80 °C
- Storage/transport: -30 °C ... +80 °C
- Mounting: -30 °C ... +80 °C



The pin assignment of the supply connection is described in the chapter "Connecting Data and Supply Cables".

Voltage cable, unshielded, 4-pin, 0.75 mm², PUR M12 connector, straight, A-coded - M12 female connector, straight, A-coded

Ordering code	Parts number	Length
RKB0046/000,2	R911172102	0.2 m
RKB0046/000,3	R911172103	0.3 m
RKB0046/000,5	R911172104	0.5 m
RKB0046/001,0	R911172105	1.0 m
RKB0046/002,0	R911172106	2.0 m

Accessories

Ordering code	Parts number	Length
RKB0046/005,0	R911172107	5.0 m
RKB0046/010,0	R911172108	10.0 m
RKB0046/000,0	R911172580	Variable length

Tab. 13-4: Supply cable, A-coded - Male and female connector

Voltage cable, unshielded, 4-pin, 0.75 mm², PUR M12 female connector, straight, A-coded - Open end

Ordering code	Parts number	Length
RKB0047/005,0	R911172100	5.0 m
RKB0047/010,0	R911172101	10.0 m

Tab. 13-5: Supply cable, A-coded - Female connector, open end

13.4 Carrier Rail Adapter, Profile Adapter and Spacer

Ordering code	Parts number	Brief description
SUP-M01-S67-0001	R911172119	Carrier rail adapter for field bus coupler
SUP-M01-S67-0002	R911172120	Carrier rail adapter for I/O modules and power distributor
SUP-M01-S67-0003	R911172121	Profile adapter for field bus coupler
SUP-M01-S67-0004	R911172122	Profile adapter for I/O modules and power distributor
SUP-M01-S67-0005	R911172123	Spacer

Tab. 13-6: Carrier rail adapter, profile adapter and spacer

13.5 End Clamp

Ordering code	Parts number	Brief description
SUP-M01-ENDHALTER	R911170685	Rapid assembly end clamp for 35 mm NS 35/7,5 or NS 35/15 carrier rail, width: 9.5 mm
SUP-M01-ENDHALTER/AL	R911171035	End clamp for 35 mm NS 35/7,5 or NS 35/15 carrier rail, model: Aluminum, 2 screws used for fixing, width: 10 mm
SUP-M01-ENDHALTER/PA	R911172352	End clamp for 35 mm carrier rail, model: Polyamide, width: 9.5 mm

Tab. 13-7: End clamp

13.6 Protective caps

Protective caps for female and male connectors that are not assigned (M8, M12)

Ordering code	Parts number	Brief description
RF-PROT-M8	R911170895	Protective cap M8 (external thread)
RF-PROT-M12-M	R911171999	Protective cap M12 (internal thread)
SUP-M01-SM*12.1	R911277260	Protective cap M12 (external thread)

Tab. 13-8: Protective caps

13.7 Module Labeling Strips

Ordering code	Parts number	Brief description
SUP-M01-S67-0006	R911172124	Labeling strips 8×M8 (for coupler / I/O modules) VPE=10

Tab. 13-9: Module labeling strips

14 Appendix

14.1 Diagnostic Information

Some field bus couplers display the error code as attribute path (CIA). The diagnostics can thus be clearly assigned. Other field bus couplers (e.g. Profinet I/O or Profibus DP) convert the attribute path into the respecting field bus-specific message.

The following diagnostic codes can be generated by the S67-DO8-M8-2A module:

Diagnostic message	Attribute path			Classification
	C	I	A	
Undervoltage U_{LS} (Sensor supply)	50	1	128	Diagnostic alarm
Undervoltage U_A (Actuator supply)	50	1	129	Diagnostic alarm

Tab. 14-1: Module diagnostics

Diagnostic message	Attribute path			Classification
	C	I	A	
Short circuit/actuator overload This function is only active if the actuator output is switched on	9	Channel (1-8)	128	Diagnostic alarm
Actuator interruption (wire breakage) This function is only active if the actuator output is switched off	9	Channel (1-8)	129	Diagnostic alarm
Overtemperature This function is only active if the actuator output is switched on	9	Channel (1-8)	130	Diagnostic alarm

Tab. 14-2: Diagnostics of individual model channels

15 Service and support

Our worldwide service network provides an optimized and efficient support. Our experts offer you advice and assistance should you have any queries. You can contact us **24/7**.

Service Germany Our technology-oriented Competence Center in Lohr, Germany, is responsible for all your service-related queries for electric drive and controls.

Contact the **Service Hotline** and **Service Helpdesk** under:

Phone: **+49 9352 40 5060**
Fax: **+49 9352 18 4941**
E-mail: service.svc@boschrexroth.de
Internet: <http://www.boschrexroth.com/>

Additional information on service, repair (e.g. delivery addresses) and training can be found on our internet sites.

Service worldwide Outside Germany, please contact your local service office first. For hotline numbers, refer to the sales office addresses on the internet.

Preparing information To be able to help you more quickly and efficiently, please have the following information ready:

- Detailed description of malfunction and circumstances
- Type plate specifications of the affected products, in particular type codes and serial numbers
- Your contact data (phone and fax number as well as your e-mail address)

Index

A

Abbreviations.....	8
About this documentation	
Validity of the documentation.....	6
Accessories.....	59
Assembled S-BUS cables.....	59
Carrier rail adapter, profile adapter and spacer.....	62
End clamp.....	62
Module labeling strips.....	63
Protective caps.....	63
Ready-made supply cables.....	61
ANSI Z535.6-2006.....	11
Appendix.....	65
Diagnostic information.....	65

C

Commissioning.....	37
Complaints.....	8
Connect data and supply cables.....	31
Connect actuator cables.....	35
Connect S-BUS.....	32
Connect supply cables.....	33
Notes.....	31
Required accessories.....	32
Connect module.....	52
Criticism.....	8
Customer Feedback.....	8

D

Device description.....	13
Connections.....	13
Dimensions.....	18
Display elements.....	15
Labeling and symbols at rear side.....	16
Labeling options and mounting.....	14
Schematic diagram.....	17
Technical data.....	18
Type plate.....	16
Diagnostics via LED signals.....	47
Operating messages of the module.....	47
Display elements.....	15
Displays.....	21
Disposal.....	52

F

Feedback.....	8
---------------	---

H

Hazard warnings.....	11
Helpdesk.....	67
Hotline.....	67

I

Intended use	
Application cases.....	9
Information on the operation.....	10
Introduction.....	9
Safety devices.....	10
Use cases.....	9

M

Maintenance and service.....	51
Connect module.....	52
Replace module.....	51
Replace module, disconnect wiring.....	51
Replace module, remove module from mounting rail.....	51
Replace module, remove module from profile adapter.....	52
Maintenance and Service	
Replace module, remove module from system.....	51
Manufacturing date.....	16
Mount module.....	23
Direct mounting to system.....	24
Mount on mounting rail.....	24
Mount on mounting rail, fasten module with mounting rail adapter on mounting rail... ..	25
Mount on mounting rail, fasten mounting rail adapter at module.....	24
Mount on profile rail.....	26
Mount on profile rail, fasten module with profile adapter on profile rail.....	27
Mount on profile rail, fasten profile adapter on module.....	26
Mounting notes.....	23
Mounting spacer in case of compact arrangement.....	28
Required tools and accessories for mounting	23
Mount modules	
Replace labeling fields.....	27

P

Parameterization.....	43
Automatic storage of system parameters.....	45
Diagnostic overview.....	43
Firmware update.....	45
Global settings for field supply.....	45
Output parameters.....	44
Parts number.....	16
Process images.....	39
Input data.....	40
Output data.....	39
Product phases.....	6

S

Safety alert symbol.....	11
--------------------------	----

Index

Safety instructions.....	11
Schematic diagram.....	17
Scope.....	5
Serial number.....	16
Service hotline.....	67
Signal words.....	11
Structure documentation.....	7
Suggestions.....	8
Support.....	67
Symbols.....	12

T

Target groups.....	6
Technical data.....	18
Communication.....	19
Diagnostics I/O.....	20
Digital outputs.....	19
Displays.....	21
Effect of operating states to output.....	20
Electrical isolation.....	20
Module supply.....	18
Parameterizable functions.....	20
Process image.....	21
Specifications, actuator selection.....	19
Standards and approvals.....	21
Technical data.....	18
Technical index.....	16
Terms.....	8
Terms and abbreviations.....	8
Type code	16
Type plate.....	16

U

Unintended use.....	10
Consequences, exclusion of liability.....	9
Use feedback-free module in safety applica- tions.....	53
Important information.....	53
Use feedback-free modules in safety applications	
Connect module to safety control devices.....	56
Connect module to safety control devi- ces, connection examples.....	57
Connect module to safety control devi- ces, General structure of a potential group....	56
Measures and requirements for shielded module voltage supply.....	55
Measures and requirements for unshiel- ded module voltage supply.....	56
Use feedback-free modules in safety ap- plications for the module supply concept.....	54

W

Warnings.....	11
---------------	----

Notes

Notes

Notes

Bosch Rexroth AG

Electric Drives and Controls

P.O. Box 13 57

97803 Lohr, Germany

Bgm.-Dr.-Nebel-Str. 2

97816 Lohr, Germany

Tel. +49 9352 18 0

Fax +49 9352 18 8400

www.boschrexroth.com/electrics



R911329562