

Change Record

Edition	Release Date	Notes
Edition 01	2011-12	First edition
Edition 02	2012-01	Supplements
Edition 03	2013-08	Supplements
Edition 04	03/2014	Supplements
Edition 05	2016-06	Supplementations, corrections

Copyright

© Bosch Rexroth AG 2016

This document, as well as the data, specifications and other information set forth in it, are the exclusive property of Bosch Rexroth AG. It may not be reproduced or given to third parties without its consent.

Liability

The specified data is intended for product description purposes only and shall not be deemed to be a guaranteed characteristic unless expressly stipulated in the contract. All rights are reserved with respect to the content of this documentation and the availability of the product.

Editorial Department

Development Automation Systems Control Platform HB (KaWa/MePe)

Table of Contents

	Page
1	About this documentation..... 1
2	Product identification and scope of delivery..... 2
2.1	Product identification..... 2
2.2	Scope of delivery..... 3
3	Use of the safety instructions..... 3
3.1	Structure of the safety instructions..... 3
3.2	Explaining signal words and safety alert symbol..... 3
3.3	Symbols used..... 4
3.4	Signal graphic explanation on the device..... 4
4	Intended Use..... 4
5	Spare parts, accessories and wear parts..... 5
5.1	Y-repeater..... 5
5.2	External 24 V power supply unit..... 5
5.3	Uninterruptible power supply (UPS)..... 6
5.4	Connecting cables for the CDI interface..... 6
5.5	USB connecting cable..... 6
5.6	USB connecting cable with increased noise immunity..... 7
5.7	Wear parts..... 7
6	Ambient conditions..... 8
7	Technical data..... 10
8	Standards..... 11
8.1	Standards used..... 11
8.2	CE marking..... 12
8.2.1	Declaration of conformity..... 12
8.3	UL/CSA certified..... 13
9	Interfaces..... 14
9.1	General information..... 14
9.2	Overview..... 14
9.3	PC voltage supply X10..... 15

	Page
9.4	USB interfaces XUSB1 to XUSB6..... 16
9.5	Ethernet interfaces XETH1 and XETH2..... 17
9.6	DVI interface XDVI..... 17
9.7	CDI interfaces XVID and XSER..... 18
9.8	Extension cards..... 19
10	Mounting, demounting and electric installation..... 20
10.1	Installation notes..... 20
10.1.1	Cables routing..... 20
10.1.2	Housing distances for maintenance tasks..... 20
10.1.3	Installing extension cards..... 21
10.1.4	BIOS settings..... 24
10.2	Housing dimensions..... 24
10.3	Electric connection..... 33
10.3.1	Connecting 24 V supply to the control cabinet PC..... 33
10.3.2	Connecting a UPS..... 33
10.3.3	Recommendation for the mounting of CDI cables with long lengths in an interference-prone environment..... 36
11	Commissioning..... 39
12	Device description..... 41
12.1	General information..... 41
12.2	Operating and error displays..... 42
13	Error causes and troubleshooting..... 43
14	Maintenance..... 44
14.1	General information..... 44
14.2	Hard disk(s)..... 45
14.3	Fan..... 46
14.4	CMOS battery..... 48
15	Ordering information..... 49
16	Disposal..... 51
16.1	Return..... 51
16.2	Packaging..... 51
16.3	Batteries and accumulators..... 51

	Page
17 Service and support	51
Index	53

1 About this documentation

Overview on target groups and product phases

In the following illustration, the framed activities, product phases and target groups refer to the present documentation.

Example: In the product phase "Mounting (assembly/installation)", the "mechanic/electrician" can execute the activity "install" using this documentation.

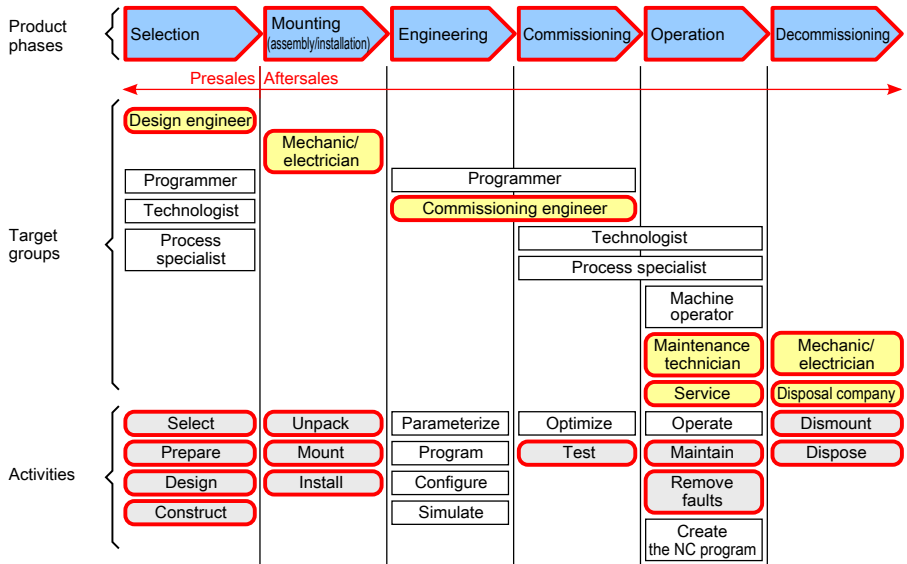

Fig. 1-1: Assigning the present documentation to the target groups, product phases and activities of the target group

Purpose

This document instructs the technical staff of the machine manufacturer on how to perform the mechanical and electrical installation safely and on how to commission the device.

Required qualifications: Individual who is able to assess the tasks assigned and identify possible safety risks owing to qualification in the subject, knowledge and experience. The individual should also be familiar with the standards and regulations.

Scope

This operating instructions applies to all variants whose type code starts with "VPBxx.3...".

The type code specifications are located on the type plate of the device. Also refer to [chapter 2 "Product identification and scope of delivery"](#) on page 2.

Related documents

Title	Part number and document type
IndraControl VAU 01.1	R911336867
UPS with Communication Interface	Operating Instructions
IndraControl VAP 01	R911339613
Power Supply Unit	Operating Instructions
IndraControl VDP 16.3, VDP 40.3, VDP 60.3	R911336378
Operator Display	Operating Instructions
IndraControl V-Devices	R911343901
Operating Systems	Project Planning Manual

Tab. 1-1: Related documents

Customer Feedback

Customer requests, comments or suggestions for improvement are of great importance to us. Please email your feedback on the documentations to Feedback.Documentation@boschrexroth.de. Directly insert comments in the electronic PDF document and send the PDF file to Bosch Rexroth.

2 Product identification and scope of delivery

2.1 Product identification

The type plate is located on the rear side or at the side of the device.

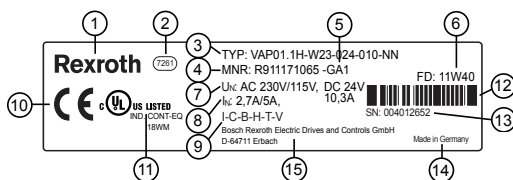
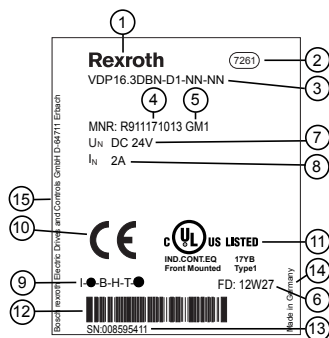

- 1 Word mark
- 2 Division or plant number
- 3 Type name (type code)
- 4 Part number
- 5 State of revision
- 6 Date of manufacture (yyWww)
- 7 Nominal voltage
- 8 Nominal current

- 9 Test marking
- 10 CE mark
- 11 Underwriters Laboratories Inc. mark
- 12 Serial number as barcode
- 13 Serial number
- 14 Name of origin

15 Company address

Fig. 2-1: Exemplary type plates

2.2 Scope of delivery

- Control cabinet PC
- Safety instructions
- 24 V female connector strip

3 Use of the safety instructions

3.1 Structure of the safety instructions

The safety instructions are structured as follows:

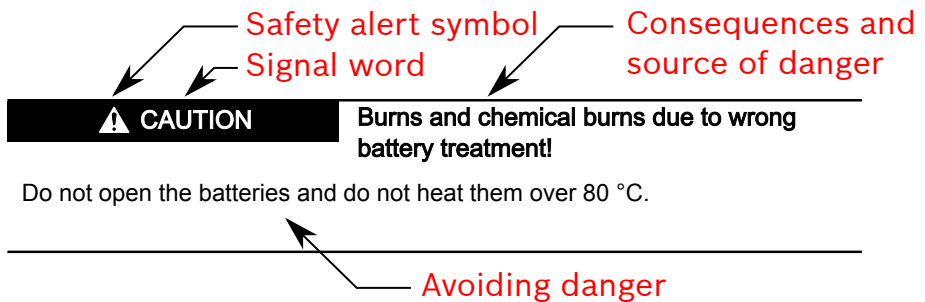

Fig. 3-1: Structure of the safety instructions

3.2 Explaining signal words and safety alert symbol

The safety instructions in this documentation contain specific signal words (danger, warning, caution, notice) and, if necessary, a safety alert symbol (according to ANSI Z535.6-2006).

The signal word is used to draw attention to the safety instruction and also provides information on the severity of the hazard.

The safety alert symbol (a triangle with an exclamation point), which precedes the signal words danger, warning and caution is used to alert the reader to personal injury hazards.

! DANGER

In case of non-compliance with this safety instruction, death or serious injury will occur.

⚠ WARNING

In case of non-compliance with this safety instruction, death or serious injury can occur.

⚠ CAUTION

In case of non-compliance with this safety instruction, minor or moderate injury can occur.

NOTICE

In case of non-compliance with this safety instruction, material damage can occur.

3.3 Symbols used

Hints are represented as follows:



This is an information.

Tips are represented as follows:



This is a tip.

3.4 Signal graphic explanation on the device



Prior to the installation and commissioning of the device, refer to the device documentation.

4 Intended Use

The control cabinet PC IndraControl VPB 40.3 forms a PC-based operator terminal when combined with a operator display (e.g. IndraControl VDP xx.3). Depending on the application or configuration, the operator terminal can also fulfil the control functionalities.

NOTICE

Danger of destruction of the device if not expressly stated accessories, mounting parts and other components, cables, lines, software and firmware are used.

The IndraControl VPB 40.3 device may be used only as intended and with the accessories, mounting parts and other components specified in this documentation. Components that are not expressly mentioned must neither be attached nor connected. The same applies to cables and lines.

Operation must only be carried out with the hardware component configurations and combinations that are expressly specified and with the software and firmware indicated and specified in the respective documentation and functional descriptions.

Typical areas of application of the control cabinet PC IndraControl VPB 40.3:

- Handling systems and assembly systems
- Food processing machinery and packaging machines
- Printing machines and paper converting machines
- Machine tools
- Wood working machines

The IndraControl VPB 40.3 device may only be operated under the assembly and installation conditions, in the position of application and under the ambient conditions (temperature, degree of protection, humidity, EMC, etc.) specified in this documentation.

5 Spare parts, accessories and wear parts

5.1 Y-repeater

Connecting unit to connect two operator displays featuring the same resolution and the same version to one control cabinet PC.

Ordering code	Part number	Description
VAC01.1S-YD1-NNNN	R911171187	Y-repeater for CDI interface

5.2 External 24 V power supply unit

External 24 V power supply unit for IndraControl V-devices.

Ordering code	Part number	Description
VAP01.1H-W23-024-010-NN	R911171065	External 24 V power supply unit for IndraControl V-devices

5.3 Uninterruptible power supply (UPS)

Ordering code	Part number	Description
VAU01.1U-024-024-240-NN	R911171024	Uninterruptible power supply DC 24 V, 240 watts with USB interface

5.4 Connecting cables for the CDI interface

Connecting cable to connect the control cabinet PC to the operator display.

Ordering code	Part number	Description
RKB0008/000,5 (*****_*****_*****)	R911171484	Length 0.5 m
RKB0008/001,0 (*****_*****_*****)	R911171485	Length 1 m
RKB0008/002,5 (*****_*****_*****)	R911170151	Length 2.5 m
RKB0008/005,0 (*****_*****_*****)	R911170152	Length 5 m
RKB0008/007,5 (*****_*****_*****)	R911172971	Length 7.5 m
RKB0008/010,0 (*****_*****_*****)	R911170153	Length 10 m
RKB0008/015,0 (*****_*****_*****)	R911171183	Length 15 m
RKB0008/020,0 (*****_*****_*****)	R911171184	Length 20 m
RKB0008/025,0 (*****_*****_*****)	R911170154	Length 25 m
RKB0008/030,0 (*****_*****_*****)	R911171381	Length 30 m
RKB0008/035,0 (*****_*****_*****)	R911171369	Length 35 m
RKB0008/040,0 (*****_*****_*****)	R911171382	Length 40 m
RKB0008/050,0 (*****_*****_*****)	R911171383	Length 50 m

Further cable lengths are available on request.



Two cables are always required to establish a connection between the VPB and the VDP.

5.5 USB connecting cable

Ordering code	Part number	Description
RKB0019/000,5 (*****_*****_*****)	R911171165	USB connecting cable, length 0.5 m
RKB0019/001,0 (*****_*****_*****)	R911171166	USB connecting cable, length 1 m
RKB0019/003,0 (*****_*****_*****)	R911171167	USB connecting cable, length 3 m

5.6 USB connecting cable with increased noise immunity



In noisy environments, use USB cables with increased noise immunity to connect the control cabinet PC to the uninterruptible power supply with communication interface.

Ordering code	Part number	Description
RKB0023/001,0 (*****_*****_*****)	R911171627	USB connecting cable with increased noise immunity, Length 1 m
RKB0023/003,0 (*****_*****_*****)	R911171414	USB connecting cable with increased noise immunity, Length 3 m

5.7 Wear parts

Wear parts are not subject to any warranty.

CMOS battery

The guaranteed service life of the CMOS battery is 5 to 7 years.

Mechanical hard disk

The hard disk is an electromechanical wear part that is subject to wear during the operating time. The service life depends on the operating hours, the number of accesses to the hard disk as well as on vibration and shocks.

Solid State Drive

The SSD (Solid State Drive) shock resistance and temperature resistance is higher than of an ordinary hard disk. The hard disk is only subject to electrical and not to mechanical wear.

NOTICE

The SSD wears faster in case of defragmentation

Defragmentation is not necessary, as an SSD is an electronic storage medium.

Fans

Fans are mechanical wear components. Their service life is extremely temperature-dependent. The service life of the fan integrated into the housing, is as follows:

Ambient temperature	Service life
40 °C	60,000 hours
70 °C	30,000 hours

6 Ambient conditions

	In operation	Transport	Storage
Max. ambient temperature	+5 °C to +45 °C	-20 °C to +60 °C	-20 °C to +60 °C
Max. temperature gradient	Temporal temperature changes up to 3 K per minute	Temporal temperature changes up to 3 K per minute	Temporal temperature changes up to 3 K per minute
Humidity	Min. rel. humidity 5 %	Min. rel. humidity 5 %	Min. rel. humidity 5 %
	Max. rel. humidity 85 %	Max. rel. humidity 85 %	Max. rel. humidity 85 %
	Min. absolute humidity 1 g/m ³	Min. absolute humidity 1 g/m ³	Min. absolute humidity 1 g/m ³
	Max. absolute humidity 25 g/m ³	Max. absolute humidity 25 g/m ³	Max. absolute humidity 25 g/m ³
	Condensation not allowed	Condensation not allowed	Condensation not allowed
	Corresponds to climatic class 3K3 acc. to EN 60721-3-3	Corresponds to climatic class 2K2 acc. to EN 60721-3-2	Corresponds to climatic class 1K2 acc. to EN 60721-3-1
Air pressure	Up to 3,000 m above sea level acc. to EN 61131-2	Up to 3,000 m above sea level acc. to EN 61131-2	Up to 3,000 m above sea level acc. to EN 61131-2
Mechanical strength	Max. vibration:	Max. shock:	Max. shock:
	Frequency range: 10 Hz to 150 Hz	15 g 11 ms	15 g 11 ms
	Excursion: 0.75 mm at 10 Hz to 57 Hz	Acc. to EN 60068-2-27	Acc. to EN 60068-2-27
	Acceleration: 1 g at 57 Hz to 150 Hz		
	Acc. to EN 60068-2-6		
Contamination level acc. to EN 60664-1	2	2	2
Overvoltage category acc. to EN 60664-1	2	-	-

Tab. 6-1: Ambient conditions

NOTICE**Defective product due to gases jeopardizing functions**

Due to the risk of corrosion, avoid sulphurous gases (e.g. sulphur dioxide (SO₂) and hydrogen sulphide (H₂S)). The product is not resistant against these gases.



The device is not resistant to gas jeopardizing the function [sulphur dioxide (SO₂), hydrogen sulphide (H₂S)].

NOTICE**Failure of the product due to contaminated air**

- The ambient air must not contain acids, alkaline solutions, corrosive agents, salts, metal vapors and other electrically conductive contaminants in high concentrations
- Housing and installation compartments must at least comply with the degree of protection IP 54 according to DIN EN 60529



This is a product that corresponds to the limit values of the emitted interference of class A (industrial environments), but not of class B (residential area and small enterprises).

When using the product in residential areas or small enterprises, the operator has to take actions to prevent radio interferences (also refer to DIN EN 55022).

7 Technical data

PC box	Type K	Type L	Type M	Type N	Type Q
Processor	The following processors are available for all types depending on the configuration: Intel® Core™ Duo L2400 1.66 GHz Intel® Core2™ Duo T7400 2.16 GHz Intel® Core™ i7-620M, 2.66 GHz Intel® Core™ i5-520M, 2.4 GHz Intel® Core™ i7-3612QE 2.1 GHz ¹⁾ Intel® Celeron® Dual-Core P4500, 1.86 GHz				
Chip set	The following chip sets are used depending on the processor: For Intel® Core™ Duo L2400 and Intel® Core2™ Duo T7400: Graphics and memory controller hub (GMHC) Intel® 82945GME Intel® I/O controller hub 82801GHM (ICH7M-DH) For Intel® Core™ i7-620M and i5-520M: Intel® QM57 Express chip set (in devices with RAID) Intel® HM55 Express chip set (in devices without RAID) For Intel® Core™ i7-3612QE: Mobile Intel® 7 Series Chipset: Intel® QM77 For Intel® Celeron P4500: HM55 Express chip set				
RAM	1 GB (4 GB max.)				
Hard disk	<ul style="list-style-type: none"> ● At least 80 GB or ● 2 × 80 GB (RAID1) or ● 32 GB SSD 				
Optional drives	–	DVD burner	DVD burner	–	DVD burner
Interfaces	<ul style="list-style-type: none"> ● 2 × RJ 45 CDI interface (Compact Display Interface) ● 1 × DVI (including analog signals) ● 6 × USB port (type A) ● 2 x Ethernet port (RJ 45, 10/100/1000 Base-T) ● 1 × voltage connection (3-pin) 				
Slots	1 × PCI	2 × PCI	4 × PCI	1 × PCI 1 × PCIe	2 × PCI 2 × PCIe
PCI card length	Max. 175 mm				
PCIe card length	Max. 175 mm				

PC box	Type K	Type L	Type M	Type N	Type Q
Degree of protection	IP 20				
Voltage supply	24 V DC (use a 24 V power supply unit acc. to DIN EN 60742, classification VDE 0551, for example the power supply unit VAP01.1H-W23-024-010-NN, part number R911171065)				
Max. power consumption (for processor type L2400)	80 W	80 W	160 W	80 W	160 W
Max. power consumption (for all processor types except for L2400)	80 W	160 W	160 W	160 W	160 W
Weight	Approx. 2.5 kg	Approx. 2.6 kg	Approx. 3.3 kg	Approx. 2.6 kg	Approx. 3.3 kg

1) When using Intel® Core™ i7-3612QE, switch on the power supply of the device twice following a battery replacement to boot the device

Tab. 7-1: Technical data of the PC box

The specified maximum power consumption is including the power consumption of the extension cards, refer to "[Power drain of the extension cards](#)" on page 19.

8 Standards

8.1 Standards used

EN Standards

The system components of the control cabinet PC VPB 40.3 correspond to the following standards:

Standard	Title
IEC 60204-1	Safety of machinery – Electrical equipment of machines – Part 1: General requirements
IEC 61558-2-6	Safety of transformers, reactors, power supply units and similar products for supply voltages up to 1100 V – Part 2-6: Particular requirements and tests for safety isolating transformers and power supply units incorporating safety isolating transformers
IEC 60664-1	Insulation coordination for equipment within low-voltage systems – Part 1: Principles, requirements and tests

Standard	Title
IEC 61131-2	Programmable controllers – Part 2: Equipment requirements and tests
ISO 13850	Safety of machinery – Emergency stop – Principles for design
IEC 60529	Degrees of protection provided by enclosures (IP code)
IEC 60068-2-6	Environmental testing – Part 2-6: Tests – Test Fc: Vibration (sinusoidal)
IEC 60068-2-27	Environmental testing – Part 2-27: Tests – Test Ea and guidance: Shock
IEC 60721-3-1	Classification of environmental conditions Part 3: Classification of groups of environmental parameters and their severities Section 1: Storage
IEC 60721-3-2	Classification of environmental conditions Part 3: Classification of groups of environmental parameters and their severities Section 2: Transportation
IEC 60721-3-3	Classification of environmental conditions Part 3: Classification of groups of environmental parameters and their severities Section 3: Stationary use at weather-protected locations

Tab. 8-1: Standards used

8.2 CE marking

8.2.1 Declaration of conformity



The electronic products described in the present operating instructions comply with the requirements and the target of the following EU directive and with the following harmonized European standards:

EMC directive 2014/30/EC

The electronic products described in the present operating instructions are intended for use in industrial environments and comply with the following requirements:

Standard	Title
IEC 61000-6-2	Electromagnetic compatibility (EMC) – Part 6-2: Generic standards – Immunity for industrial environments
IEC 61000-6-4	Electromagnetic compatibility (EMC) – Part 6-4: Generic standards – Emission standard for industrial environments

Tab. 8-2: Standards for electromagnetic compatibility (EMC)



Loss of CE conformity due to modifications at the device

CE marking applies only to the device upon delivery. After modifying the device, verify CE conformity.

8.3 UL/CSA certified



The devices are certified acc. to

- **UL508** (Industrial Control Equipment)
- **C22.2 no. 142-M1987** (CSA)

UL file no. E210730

However, there can be combinations or extension stages with a limited or missing certification. Thus, verify the registration according to the UL marking on the device.



Loss of UL/CSA conformity due to modifications at the device

UL and CSA marking applies only to the device upon delivery. After modifying the device, verify UL and CSA conformity.

9 Interfaces

9.1 General information

NOTICE

Material damages to electronics due to missing functional earth!

Ensure that the functional earth is connected, as otherwise the electronics can be destroyed by a potential difference between the operator display and the control cabinet PC if the voltage supply is interrupted to only one device and established again. A direct connection of the functional earth between operator display and control cabinet PC is optimal. If the functional earth is connected to a neutral point, the control cabinet PC and the operator display have to be connected to this neutral point.



To avoid malfunctions, use only shielded cables and metallic or conductive connector/coupling housings with large-area shield support.

9.2 Overview

The following connections are available at the control cabinet PC:

Labeling at the housing	Connection type	Connector type (at the device)	Mating connector or cable (from outside)
X10	PC voltage supply: DC 24 V	Male connector terminal PC4/3-G7.62	Socket terminal PC4/3-G7.62
XDVI	DVI monitor or analog monitor (via adapter)	DVI(A) socket (24-pin and 5-pin)	DVI connector
XSER	CDI interface, data	RJ45 socket, 8-pin	RJ45 plug (Twisted pair, 8-wire)
XVID	CDI interface, image	RJ45 socket, 8-pin	RJ45 plug (Twisted pair, 8-wire)
XETH1, XETH2	Ethernet interfaces 10/100/1000 Base-T	RJ45 socket, 8-pin	RJ45 plug (Twisted pair, 8-wire)
XUSB1 to XUSB6	USB interfaces	USB socket, 4-pin, type A	USB plug, 4-pin

Internal connections for extension cards

1, 2 slots or 4 slots (see " Available slots per PC box type " on page 19)	PCI/PCIe	PCI/PCIe card
--	----------	---------------

9.3 PC voltage supply X10

The 24 V DC voltage supply for the control cabinet PC is connected via the "X10" connection.

All voltages internally required are generated without any electrical isolation via a DC/DC converter. The connection is designed as spring terminal, SPC 5/3-ST-7,62, 3-pin, grid 7.62 mm. Connect cables with the conductor cross-sections listed in tab. "The following conductor cross-sections are permitted for the spring terminal at X10:" on page 16 to it.

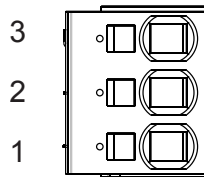

Fig. 9-1: 24 V DC connection, X10, pin assignment

Pin	Labeling	Function
1	+	Supply voltage 24 V
2	-	0 V supply voltage
3	U	Supply voltage in front of UPS available (see chapter "UPS without USB interface" on page 36)

NOTICE

Destruction of the control cabinet PC (fire hazard) due to polarity reversal of the connection at the X10 plug without additional external protection

Ensure that the polarity at the X10 plug and the dimensioning of the fuse are correct.



WARNING

Danger without safe separation!

The 24 V DC input voltage must comply with the requirements of the "safe separation"!

Plug and remove the plug connection only if there is no voltage!

The following conductor cross-sections are permitted for the spring terminal at X10:

Conductor	Cross-section
Conductor cross-section inflexible, max.	10 mm ²
Conductor cross-section inflexible, recommended	2.5 mm ²
Conductor cross-section flexible, max.	6 mm ²
Conductor cross-section flexible, recommended	2.5 mm ²
Conductor cross-section flexible with core end sleeves without plastic sleeve, max.	6 mm ²
Conductor cross-section flexible with core end sleeves without plastic sleeve, recommended	2.5 mm ²
Conductor cross-section flexible with core end sleeves with plastic sleeve, max.	4 mm ²
Conductor cross-section flexible with core end sleeves with plastic sleeve, recommended	2.5 mm ²
Conductor cross-section AWG/kcmil, max.	8
Conductor cross-section AWG/kcmil, recommended	13

9.4 USB interfaces XUSB1 to XUSB6

The devices are provided with six USB interfaces on the connector panel (XUSB1/2 XUSB3/4 and XUSB5/6).

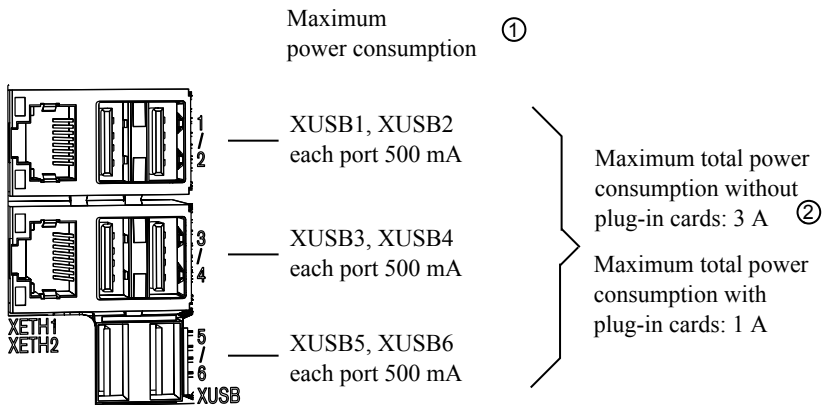

Fig. 9-2: Current carrying capacity of the six USB connections



①: The USB ports are monitored in pairs. If, e. g. XUSB1 switches off, as the power consumption has been exceeded (> 500 mA), XUSB2 switches off as well.



②: The specified 3 A are applied for the operation without further 5 V consumers (e. g. PCI plug-in cards). Limit the operation with further 5 V consumers to a total power consumption of 1 A to avoid that the internal power supply unit switches off accidentally.



If the maximum power consumption has been exceeded, a message is displayed that the USB devices are disabled. The USB devices operate again as soon as less than 500 mA current is consumed from a USB socket. Additionally, the USB error message in the taskbar has to be acknowledged manually.



Connect only USB devices which comply with the noise immunity according to the EMC directive (industrial environments). This avoids an unintended switch-off of the control cabinet PC.

9.5 Ethernet interfaces XETH1 and XETH2

The control cabinet PC can be connected to an Ethernet network via the Ethernet interfaces XETH1 and EXTH2.

The LAN assignment under Windows to the XLAN connections at the device is set as follows by default:

Labeling under Windows	Labeling at the device
Local Area Connection	XETH1
Local Area Connection 2	XETH2

RJ45, socket, 8-pin

Type:	Ethernet 10 Base-T, 100 Base-T, 1000 Base-T
Cable length:	100 m max.
Transmission rate:	10, 100 or 1000 MBit/s

9.6 DVI interface XDVI

At the DVI connection (XDVI), an external monitor with DVI interface or an analog monitor (via adapter) can be connected.

DVI socket, 24 + 5-pin

Cable length:	1.5 m max.
Cable type:	Shielded, cross-section min. 0.14 mm ²
Max. resolution:	2048 × 1536 (QXGA) @ 70 Hz, max. 4294 mill. colors

The resolution and number of the colors are set in the control panel of the operating system.

NOTICE

Wrong settings of resolution and color may destroy the monitor!

Observe the technical data of the monitor and adapt the operating system settings accordingly.



The BIOS is configured and thus ensures that all connected output devices can be controlled while booting.

Exception: An operator display and a DVI monitor are connected. In this case, the image is only output on the DVI monitor while booting.

If the operator display does not output an image, set the image output manually. There are two options:

1. Click on the icon of the graphics driver and select "Graphic properties". Select and confirm "Intel Dual Display Clone" under "Multiple displays".



Fig. 9-3: Graphics driver icon in the task bar

2. Under Windows, use the shortcuts <Ctrl>+<Alt>+<F4> to switch between the DVI monitor and the VDP operator display. To start the image output on an analog monitor, press <Ctrl><Alt><F1>.

The graphics driver stores the last output device. After a restart, the images are only output on the last saved output device.

9.7 CDI interfaces XVID and XSER

The CDI interface is assigned to the two RJ45 sockets XSER and XVID. Connect the operator display to these sockets. The corresponding cables are available as accessories, see [chapter 5.4 "Connecting cables for the CDI interface" on page 6](#).

The CDI interface includes the data interface (XSER) as well as the image interface (XVID).

The USB signals and the digital data (touch, M-keys, LEDs and control signals) are transferred via the data interface.

The DVI signals are transferred via the display interface.



To avoid malfunctions, use only cables listed in [chapter 5.4 "Connecting cables for the CDI interface" on page 6](#).

The CDI interfaces are color-coded on the device:

CDI interface, data (XSER)	Violet
CDI interface, image (XVID)	Black

9.8 Extension cards

To plug extension cards, up to four slots for PCI and PCIe cards are available. The number of slots available depends on the PC box type (refer to the following table). The maximum length allowed for the cards is 175 mm.

Available slots per PC box type

PC box type	Slot A1	Slot A2	Slot A3	Slot A4
Type K	PCI	–	–	–
Type L	PCI	PCI	–	–
Type M	PCI	PCI	PCI	PCI
Type N	PCI	PCIe	–	–
Type Q	PCI	PCI	PCIe	PCIe

Power drain of the extension cards

The total power allowed to be drained from the slots depends on the processor used (refer to the following table).

Slots	Intel Core™ Duo L2400 1.66 GHz processor	Intel Core2™ Duo T7400 2.16 GHz processor Intel® Core™ i7-620M, 2.66 GHz Intel® Core™ i5-520M, 2.4 GHz Intel® Core™ i7-3612QE 2.1 GHz Intel® Celeron® Dual-Core P4500, 1.86 GHz
1 slot	25 W	23 W
2 slots	40 W	50 W
4 slots	100 W	95 W
at an ambient temperature of up to 35 °C		
4 slots	100 W	50 W
at an ambient temperature between 35 and 45 °C		

Tab. 9-1: Maximum power consumption of the extension cards in total

10 Mounting, demounting and electric installation

10.1 Installation notes

10.1.1 Cables routing

- Lay all connecting cables in loops and use strain reliefs for all cables
- Keep the maximum distance possible from interference sources
- Do not lay the CDI cables in parallel to motor cables or to other noise sources, as the CDI connection can be disturbed

10.1.2 Housing distances for maintenance tasks

Provide a minimum space of 50 mm (exception above: 120 mm) on all sides for sufficient cooling and for cable routing

Comply with the following housing distances to execute maintenance tasks directly at the device in the control cabinet:

- To maintain the fan and exchange the battery, go up by 120 mm
- For the DVD drive and exchange of the hard disk, go forward by 150 mm

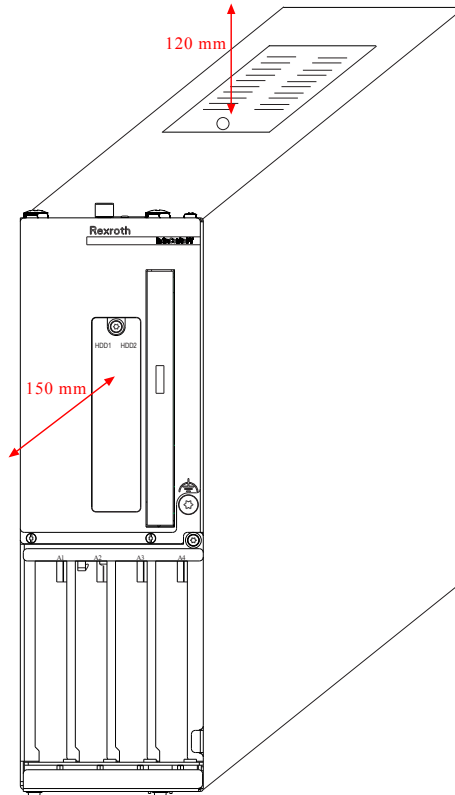

Fig. 10-1: Housing distances for maintenance tasks

10.1.3 Installing extension cards

NOTICE

Damages to the device due to electrostatic discharges!

Comply with all ESD protective measures while working with modules and components! Avoid electrostatic discharges!

NOTICE

Risk of damage to the IndraControl VPB 40.3 or corruption of application software due to the use of non-released extension cards!

- Install only released extension cards
- The extension cards may only be installed by authorized personnel

Steps 1 - 3 are omitted if the control cabinet PC is not yet installed in the control cabinet.

1. Switch off the supply voltage.
2. If operated with a UPS, wait until the control cabinet PC switches off automatically. The UPS LED on the connector panel of the control cabinet PC is red until the UPS switches off the power supply unit.
3. Remove all plugs from the control cabinet PC.
4. **For control cabinet PCs with one or two slots:**

Remove the fastening screws (internal hexagon T10) of the housing cover, see ① in the following table.

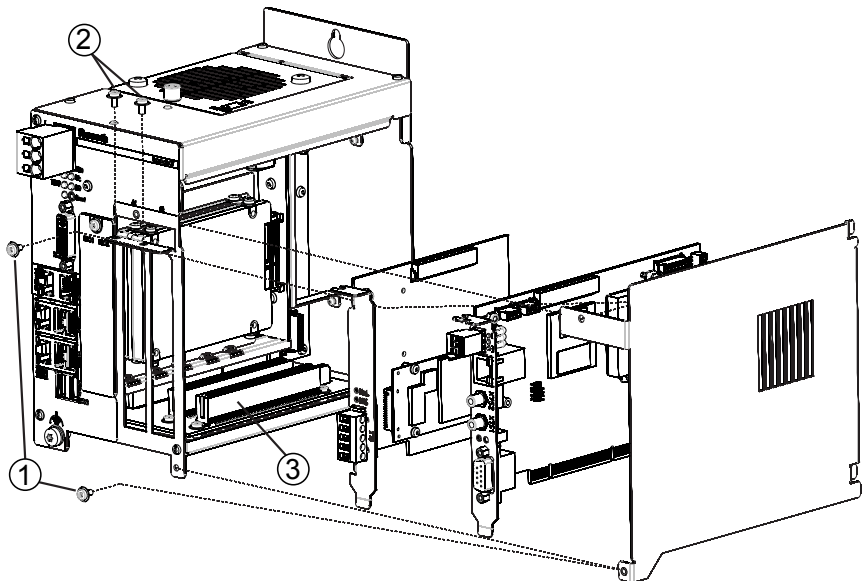

- | | |
|--|--|
| ① Fastening screw of the housing cover (internal hexagon T10) | ③ 1 PCI or 2 PCI/PCIe slots (depends on the PC box type) |
| ② Fastening screw(s) of the slot cover(s) (internal hexagon T10) | |

Fig. 10-2: Position of the housing cover and of the fastening screw(s) for control cabinet PCs with one or two slots

For control cabinet PCs with four slots:

Remove the fastening screws (internal hexagon T10) of the housing cover, see ① in the following table.

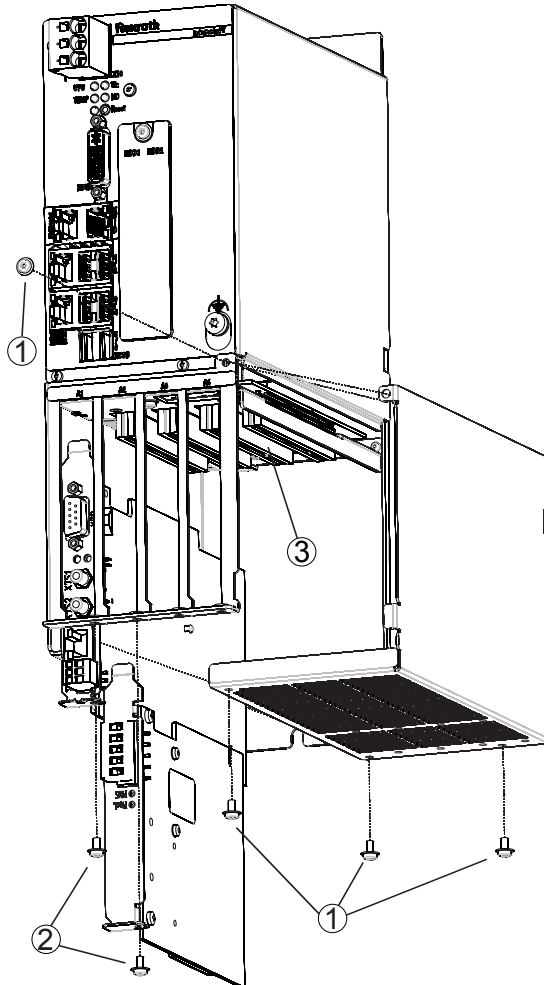

- | | |
|--|---|
| ① Fastening screws of the housing cover (internal hexagon T10) | ③ 4 PCI/PCle slots (depends on the PC box type) |
| ② Fastening screws of the slot cover (internal hexagon T10) | |

Fig. 10-3: Position of the housing cover and of the fastening screws for control cabinet PCs with four slots

5. Remove the housing cover.

6. Remove the fastening screw (internal hexagon T10) of the slot cover and the slot cover.
7. Insert the extension card and fix it using a fastening screw.
8. Mount the housing cover.

If the card is equipped with a Plug-and-Play (PnP) function, the card is automatically detected by the operating system and integrated in the system, provided that there are no hardware conflicts (IRQ etc.) with other extension cards or connected devices.

There are the following causes that the functions of the new card are not available after the system boot:

- The card is not correctly positioned in the slot
- The driver software of the card is not or incorrectly installed
- IRQ (Interrupt) conflict with other hardware components of the control cabinet PC
- The software of the card is not installed

10.1.4 BIOS settings

No further settings have to be made in the BIOS setup. The corresponding settings have already been set for the normal operation.

If the interrupts have to be changed for specific plug-in cards, call the BIOS setup with while booting.

Interrupts

Free interrupts are available on the slots A1, A2 and A4 for the following processor types:

- Intel Core™ Duo L2400 1.66 GHz
- Intel Core2™ Duo T7400 2.16 GHz

Free interrupts are available on the slots A1 and A2 for the following processor types:

- Intel® Core™ i7-620M, 2.66 GHz
- Intel® Core™ i5-520M, 2.4 GHz
- Intel® Celeron® Dual-Core P4500, 1.86 GHz

For Intel® Core™ i7-3612QE 2.1 GHz processors, free interrupts are provided on the slots A3 and A4.

10.2 Housing dimensions

The control cabinet PC can be mounted using mounting holes. For the corresponding dimensions, please refer to the following figures:



Fix the devices with M5 screws.

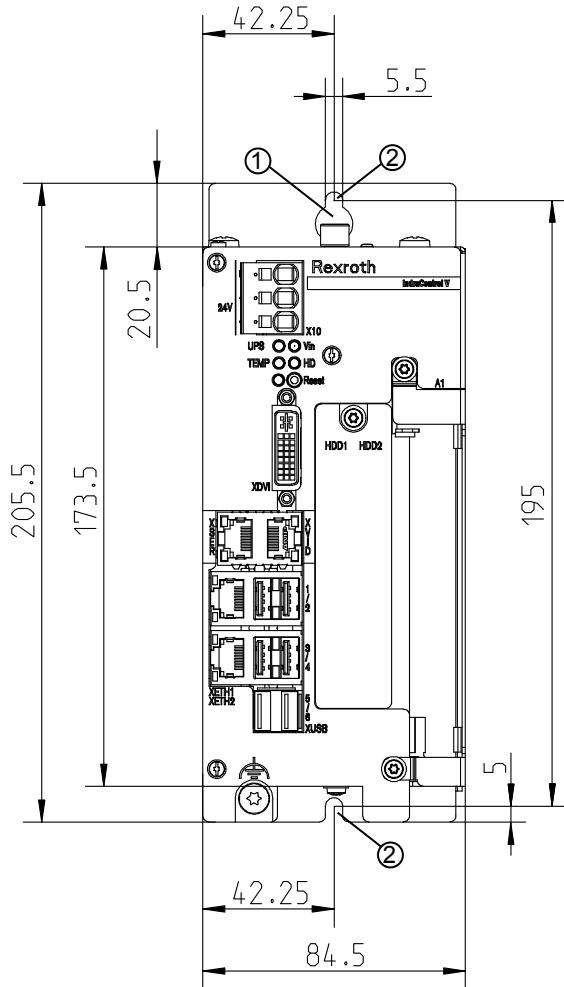

- ① Keyhole for vertical mounting
- ② Slots to hang in the device

Fig. 10-4: Housing dimensions for devices with one slot, vertical mounting

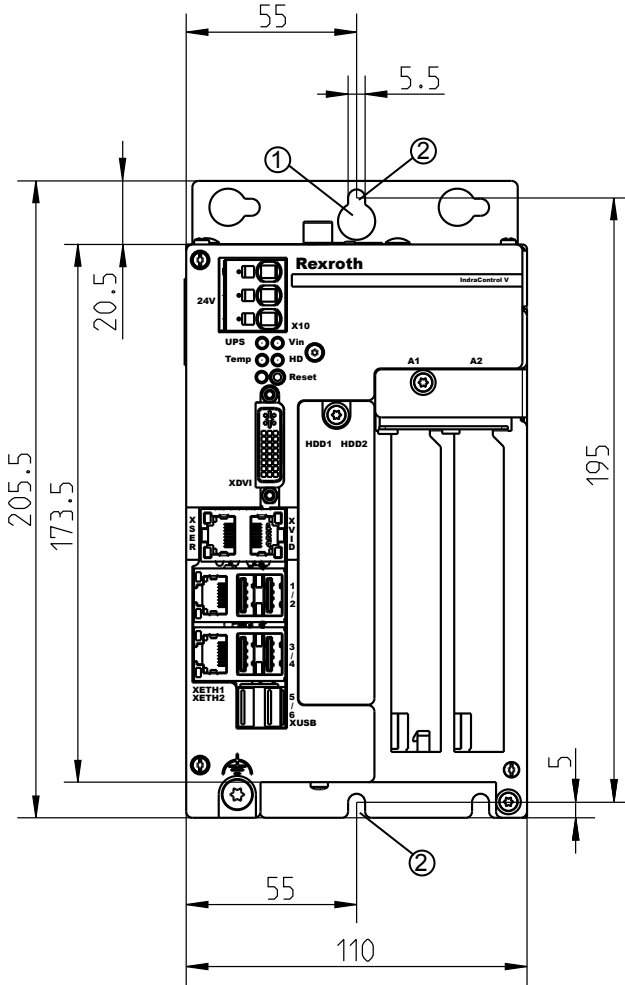

- ① Keyhole for vertical mounting
- ② Slots to hang in the device

Fig. 10-5: Housing dimensions for devices with two slots, vertical mounting

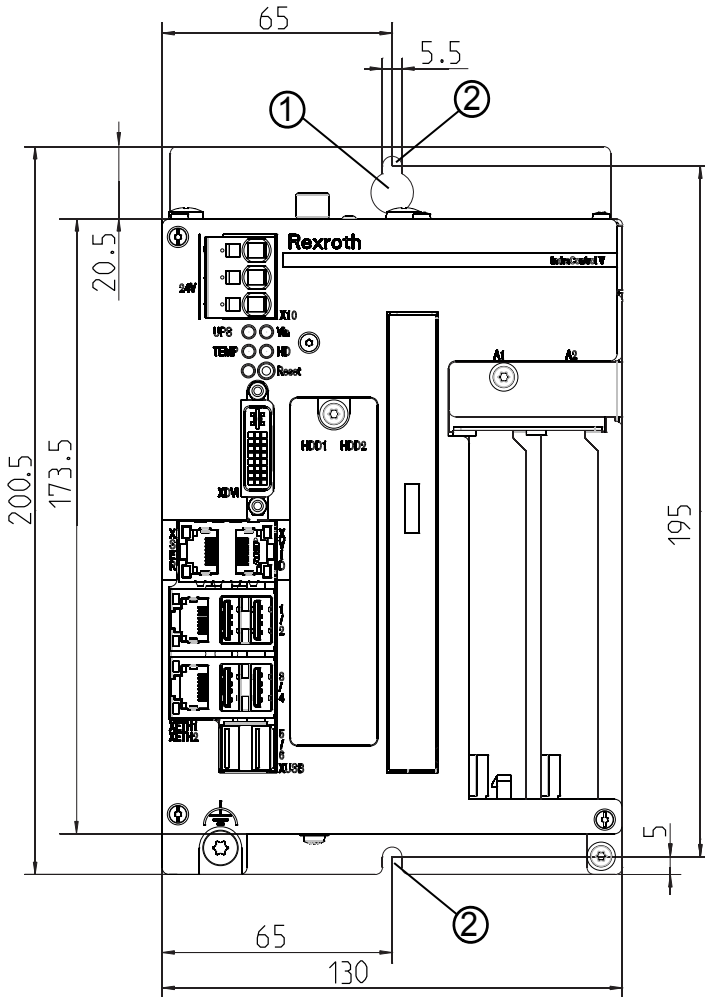

- ① Keyhole for vertical mounting
- ② Slots to hang in the device

Fig. 10-6: Housing dimensions, devices with two slots and DVD drive, vertical mounting

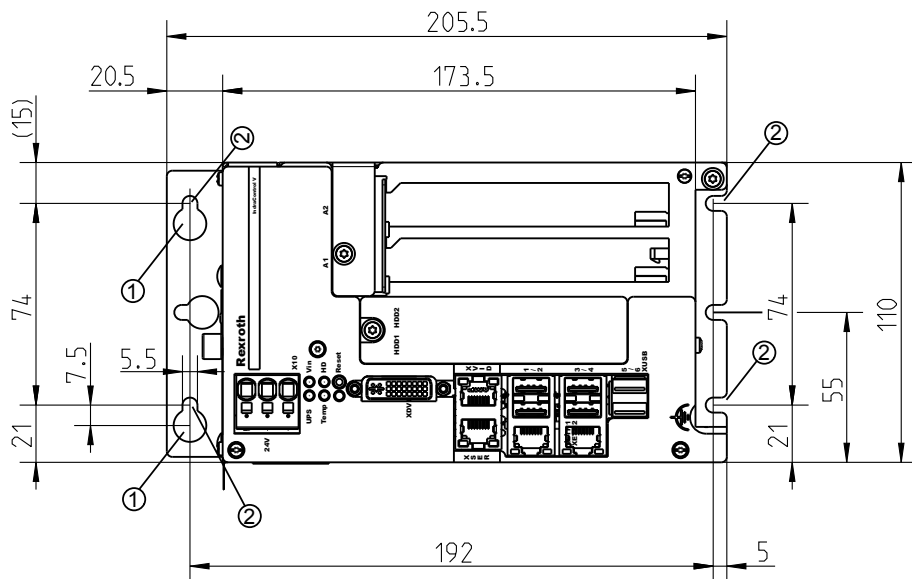

- ① Key holes for horizontal mounting
- ② Slots to hang in the device

Fig. 10-7: Housing dimensions for devices with two slots, horizontal mounting

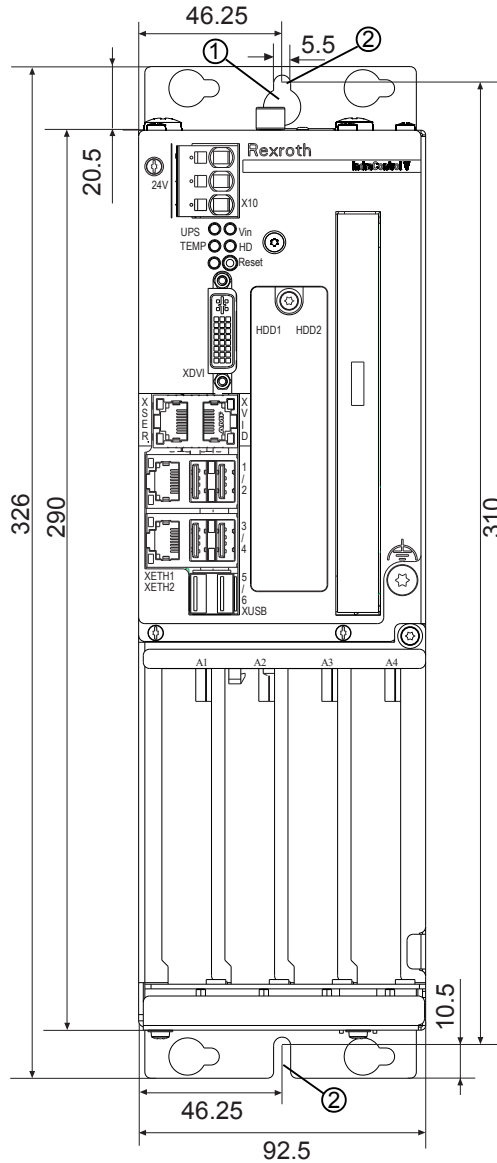

- ① Keyhole for vertical mounting
- ② Slots to hang in the device

Fig. 10-8: Housing dimensions for devices with four slots and optional DVD drive, vertical mounting

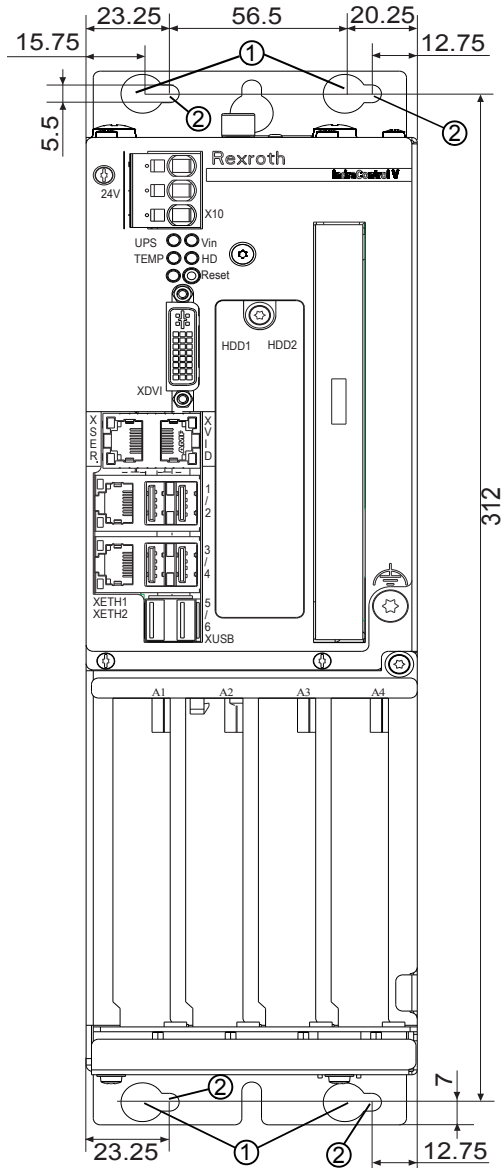

- ① Key holes for horizontal mounting
- ② Slots to hang in the device

Fig. 10-9: Housing dimensions, devices with four slots and optional DVD drive, horizontal mounting

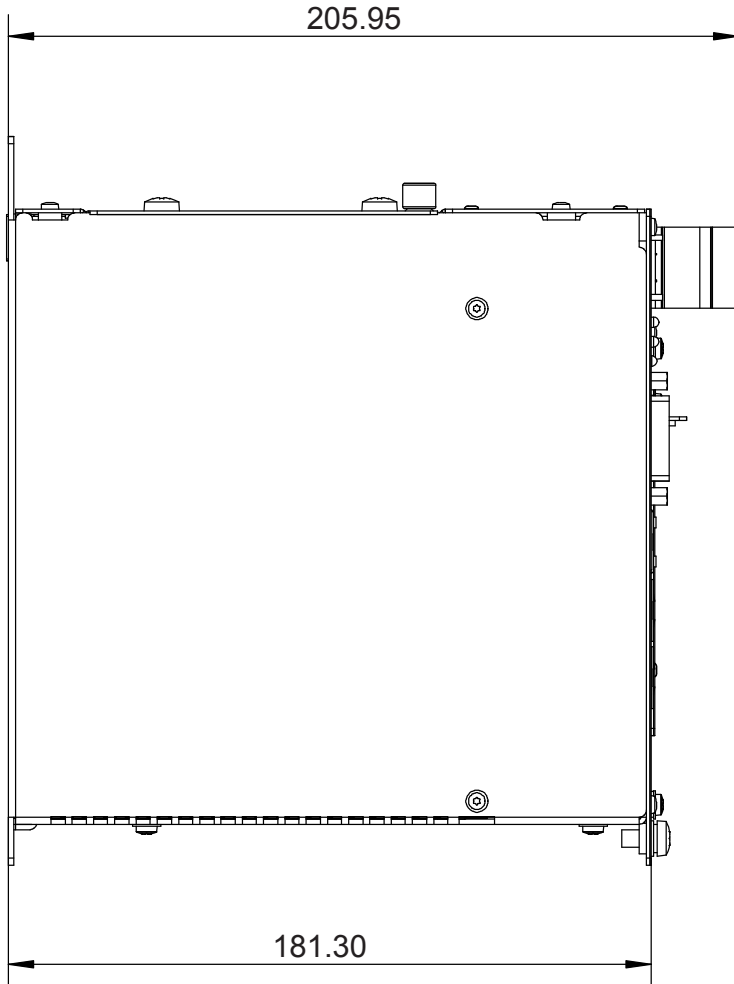

Fig. 10-10: Housing dimensions for devices with one or two slots, side view

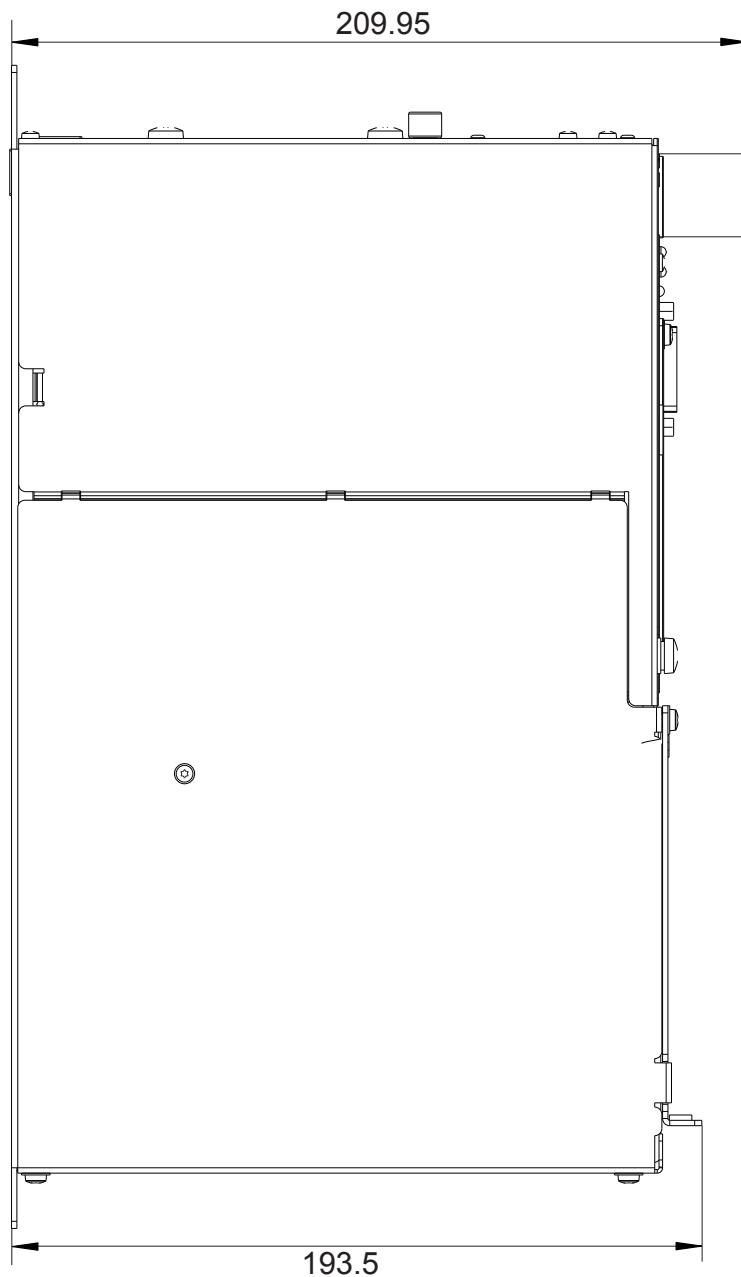

Fig. 10-11: Housing dimensions, devices with four slots, side view

10.3 Electric connection

10.3.1 Connecting 24 V supply to the control cabinet PC

1. Connect the functional earth.



2. Connect the "X10" interface for the 24 V voltage supply to the industrial power supply unit or to the UPS (if available).

For details on how to connect to a UPS, refer to [chapter 10.3.2 "Connecting a UPS" on page 33](#).

NOTICE

Material damages to electronics due to missing functional earth!

Ensure that the functional earth is connected, as otherwise the electronics can be destroyed by a potential difference between the operator display and the control cabinet PC if the voltage supply is interrupted to only one device and established again. A direct connection of the functional earth between operator display and control cabinet PC is optimal. If the functional earth is connected to a neutral point, the control cabinet PC and the operator display have to be connected to this neutral point.

For the voltage supply, use a 24 V industrial power supply unit acc. to DIN EN 60742, classification VDE 0551, for example "VAP01.1H-W23-024-010-NN" (part number R911171065).

10.3.2 Connecting a UPS

General information



Please note that the maximum power consumption of the control cabinet PC does not exceed the maximum output power of the UPS.

Connection diagram

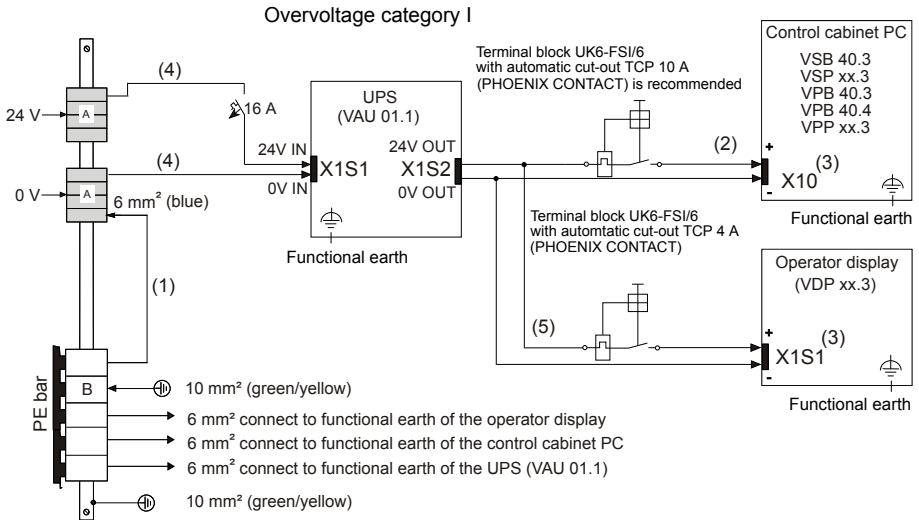

- A** Terminal block 4 mm²
- B** Serial terminal 10 mm²
- ① Easy to remove and visible
- ② Cable length between the UPS and the control cabinet PC is max. 2 m at a cross-section of min. 2.5 mm²
- ③ Polarity reversal of the XS1 and X10 connectors can sporadically result in destruction of the device (fire hazard) if no additional external protection is provided. The reason is a simultaneous grounding of the 0 V of the device and of the 0 V (PELV) (1)
- ④ Cable length between +24 V power supply unit and UPS: 1 m to 7 m, 2.5. mm² cross-section, 8 m to 10 m, 4.0 mm² cross-section (refer to the documentation of the UPS VAU01.1)
- ⑤ Cable length between +24 V power supply unit and operator display is max. 30 m at a cross-section of min. 1.5 mm². Above 30 m, a separate power supply unit is required

Fig. 10-12: Control cabinet PC and operator display connected to a UPS

UPS with USB interface

When connecting a UPS to a USB interface at the control cabinet PC, the information on the availability and the state of the UPS are communicated to the control cabinet PC.

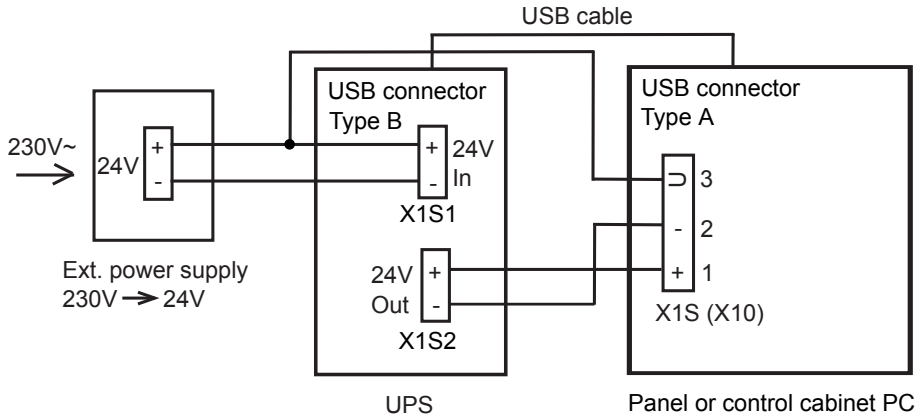

Fig. 10-13: Preferred wiring: Connection scheme with power supply unit, UPS and panel PC or control cabinet PC for normal mode with fallback and simple mode

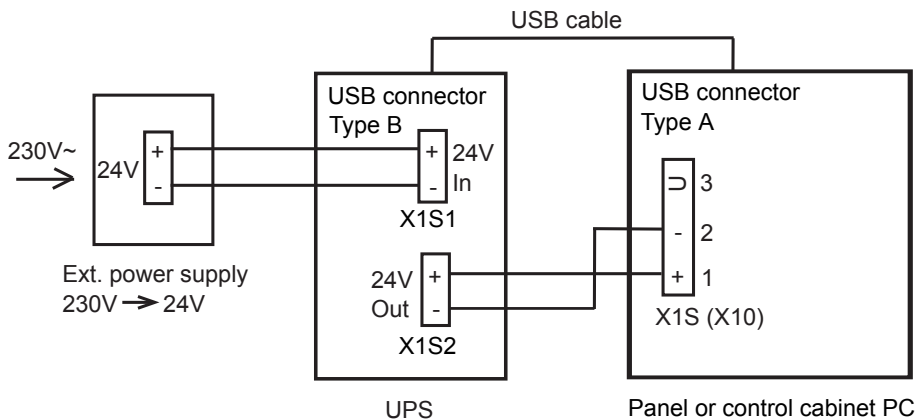

Fig. 10-14: Connection scheme with power supply unit, UPS and panel PC or control cabinet PC without fallback and simple mode

The communication is established via a virtual COM interface. This virtual COM interface is provided by the USB interface.



The driver is installed after the first connection of the UPS via the USB cable. A virtual COMn (e.g. COM3) interface is created in the operating system.

UPS without USB interface

To identify the connection of this UPS using the power pack electronics in the control cabinet PC, the 24 V voltage (24 V In), which is applied to the UPS input, is to be connected to pin 3 of the X10 (U).

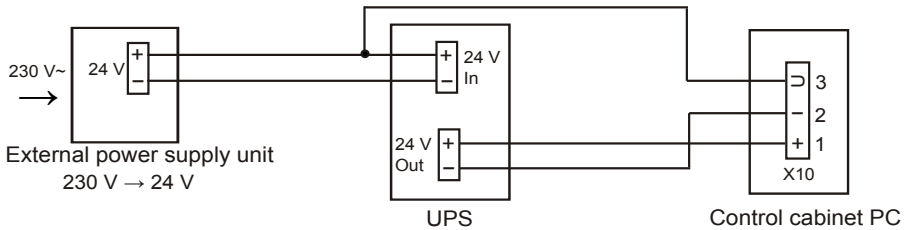

Fig. 10-15: Connecting an external UPS without communication to the control cabinet PC

NOTICE

Wrong initialization of the CDI interface and no image output at the connected display VDP xx.3 if the input voltage has been switched on too early

If the control cabinet PC is shut down under Windows and the 24 V input voltage is switched off, the input voltage can only be switched on again when the V_{IN} LED is off.

10.3.3 Recommendation for the mounting of CDI cables with long lengths in an interference-prone environment

General information

The CDI cable is a connection cable with RJ45 plug to connect the CDI interface of the control cabinet PC to the remote operator display or the Y-repeater.

The mounting recommendations described in the following facilitate an optimized signal transmission. In particular in case of great cable lengths and distances between the control cabinet PC and the remote operator display, ensure that the cable is routed correctly and that the shield is connected correctly.

Cables routing

Observe the following when laying the cables:

- Keep the maximum possible distance to interference-prone cables and lines
- Limit parallel routing with other lines
- Keep the maximum possible distance to sources of interference such as drives and frequency converters
- Mechanical protection against tensile load and compressive load on the cables

- Comply with the permissible bending and torsional stress of the cable

Potential equalization

Ensure that no compensating current flows via the cable shield of the CDI cables between device parts and machine parts during the establishment of the equipotential bonding.

Shielding

The shielding is an important part of the CDI cable. The shielding is used to shield the data wires in the cable against electrical interferences from the environment.

The shielding has to be connected to the potential equalization of the devices to shield the data wires. In most cases, a connection via the RJ45 connectors is sufficient.

Avoid collection of dirt at the RJ45 plug which can occur while drawing in the cables in the system.

Remove any collection of dirt from the shield surfaces of the RJ45 plug before plugging it in.



Fig. 10-16: RJ45 plug shielding areas

Additional shielding connection in case of strong electrical interferences and long cables

In case of strong electrical interferences and long cable lengths, it can be required to additionally connect the shielding to the earthing potential.

Mount suitable EMC shielding clamp close to the control cabinet PC, the remote operator display or the Y-repeater.

Ensure that the CDI cable is not crimped when connecting the shielding to the equipotential bonding. Avoid mechanical stress (tensile, compressive) on the plug. Use an EMC shielding clamp suitable for the cable diameter. Crimping the cable impairs the electrical properties of the CDI cable.

Observe the following when mounting the shielding connection:

1. Only remove the CDI cable jacket on the length required for the connection.



The CDI cable is sensitive to mechanical load where the jacket was removed. Ensure that the CDI cable shielding is not damaged when removing the cable jacket.



Fig. 10-17: CDI cable with RJ45 plug



Fig. 10-18: CDI cable with partially removed jacket

2. Remove the foil shield.



CDI cables are equipped with an additional foil shield. The foil shield must not be used for the connection. For an improved stability, the foil shield is usually plastic-coated on one side. The plastic coating is insulating.



Fig. 10-19: Foil shield of the CDI cable



Fig. 10-20: Foil shield removed

3. Fastening the cable with EMC shielding clamp.



Ensure that the CDI cable is not crimped when connecting the shielding to the equipotential bonding. Use an EMC shielding clamp suitable for the cable diameter. Crimping the cable impairs the electrical properties of the CDI cable. Avoid mechanical stress (tensile, compressive) on the plug.

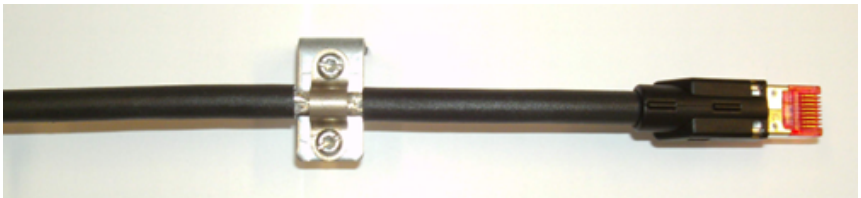

Fig. 10-21: Example: Attached shielding clamp

More shielding clamps:



- ① Company Ikotec
- ② Company Phoenix Contact

Fig. 10-22: Shielding clamps

11 Commissioning

The product can be used directly. No configuration is required.

For software descriptions, refer to the project planning manual "IndraControl V-Devices Operating Systems" (see [tab. 1-1 "Related documents" on page 2](#)). The following functions are described in this project planning manual:

- Windows XP Multilingual User Interface (MUI)
- Settings for dual monitor operation
- Data backup using the "Acronis" backup and recovery software
- Software for UPS monitoring
- Software for touch calibration and SMART analysis
- Simulation of the right mouse key
- Hardware event monitoring with response trigger
- Auto login
- M-key UpperClass filter for downwards compatibility of the M-key codes
- RAID system for higher data security and fast data access

12 Device description

12.1 General information

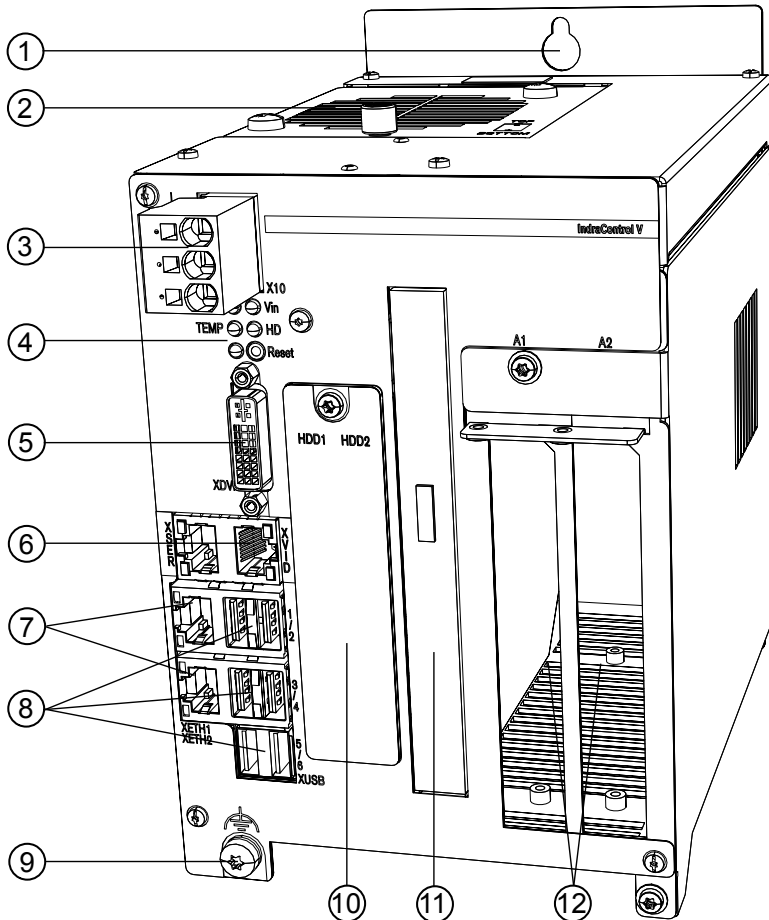

- | | |
|--|-------------------------------------|
| ① Keyhole for vertical mounting | ⑦ Ethernet interfaces |
| ② Fan | ⑧ USB interfaces |
| ③ Plug for voltage supply | ⑨ Grounding screw (hexalobular T25) |
| ④ Status LEDs and Reset button | ⑩ Hard disk(s) |
| ⑤ DVI connection | ⑪ DVD drive |
| ⑥ CDI interface (data interface and image interface) | ⑫ Features for extension cards |

Fig. 12-1: Front view of a VPB 40.3 control cabinet PC, type L

NOTICE

Data loss caused by incorrect switch-off without UPS

In case of a missing UPS, switch off the control cabinet PC via the software of the operating system only and not by interrupting the current supply. **This applies particularly for RAID systems.**

12.2 Operating and error displays

There are four LEDs on the connector panel of the IndraControl VPB 40.3 to display the device states and errors. Apply the specified measure if one of the following LEDs indicates either an error or a note, see [tab. 12-1 "LEDs for operating and error display on the connector panel"](#) on page 42.



Some LEDs, e.g. the CPU temperature monitoring, are only active if the service software has been configured accordingly.

LED	Display	Meaning	Action
V _{in}	LED green	Normal operation	–
	LED off	No supply voltage (24 V DC)	Check the supply voltage at the power supply unit!
TEMP	LED off	Normal operation	–
	LED is flashing red (flashing frequency approx. 2 Hz)	Fan is not rotating or is rotating too slowly	Check fan on the control cabinet PC!
	LED red	Overtemperature	Reduce the ambient temperature!
UPS	LED off	Normal operation	–
	LED red	The control cabinet PC is currently operating in battery mode, i. e. no supply voltage is available!	Restore the power supply and initiate a controlled restart!

LED	Display	Meaning	Action
HDD	LED flashing green	Hard disk access	–
	LED is flashing green (with a flashing frequency of approx. 2 Hz) ¹⁾	Warning: SMART analysis is identifying errors. Observe that this warning message is not displayed if RAID is used	Exchange hard disk
Reset	LED red	Monitoring LED for the “Reset” button. The LED is on as long as the “Reset” button is pressed	–

Tab. 12-1: LEDs for operating and error display on the connector panel

NOTICE

Wrong initialization of the CDI interface and no screen outputs at the connected display VDP xx.3 if the input voltage has been switched too early.

If the control cabinet PC is shut down under Windows and the 24 V input voltage is switched off, the input voltage can only be switched on again when the V_{IN} LED is off.

13 Error causes and troubleshooting

For information on the error display on the front panel, refer to [chapter 12.2 "Operating and error displays"](#) on page 42.

Errors	Troubleshooting
Wrong display resolution	<ul style="list-style-type: none"> ● Set the correct display resolution in the graphics driver ● Restart the control cabinet PC
The device switches off unintendedly	Check the max. current consumption of the connected USB devices

1) Provided that the IPC Service program (IPCSvc) is installed

Errors	Troubleshooting
No image output	<ul style="list-style-type: none"> ● Check that both CDI cables (XSER and XVID) are connected ● Check that the CDI cables (XSER and XVID) are not interchanged
No or incorrect network data transmission if the data transmission rate is set manually	The network card of the remote station has to be able to process the same data transmission rate as the control cabinet PC. If necessary, change the data transmission rate in Control Panel ► Network Card

Tab. 13-1: Error causes and troubleshooting



Repairs at the device by the customer are not permitted. Exceptions are maintenance works listed in the chapter "Maintenance".

For further information in the event of repair, please contact the Bosch Rexroth Service.

14 Maintenance

14.1 General information



Only the maintenance works at the device listed in this chapter are permitted.

For further information in the event of repair, please contact the Bosch Rexroth Service.

NOTICE

Dissolving the labeling at the device by solvents!

- Do not use any solvents (e. g. diluents) for cleaning!

NOTICE

Destruction of screw terminals, insufficient contact and loss of UL certification if no copper wire is used or due to wrong tightening torque.

Use only copper wire for wiring the connection terminals. Tighten the screws of the screw terminals with the following torque:

Thread	Tightening torque
M2,5	0.4 Nm
M3	0.7 Nm

Thread	Tightening torque
M4	1.4 Nm
M5	2.8 Nm

Tab. 14-1: Tightening torques



Ensure that the IP degree of protection of the device is kept during maintenance.

Include the following tasks into the maintenance schedule:

- Check all plug and terminal connections of the components for proper tightness and possible damage at least once a year. Check that cables are not broken or crushed. Replace damaged parts immediately
- Check the fan regarding soiling and increased running noise at least once a year



Function compatibility for spare parts is ensured for at least five years.

14.2 Hard disk(s)

The hard disk(s) is/are mounted on a carrier plate that can be pulled out from the housing. The hard disk(s) can be replaced, including the installation frame.

NOTICE

Damages to the device due to electrostatic discharges!

Comply with all ESD protective measures while working with modules and components! Avoid electrostatic discharges!



To avoid data loss and new installations of the operating system and application programs, backup hard disk data regularly.



The new hard disk(s), including the installation frame, is/are provided upon delivery. The new hard disk(s) is/are always installed with the installation frame.

To exchange the hard disk(s), proceed as follows:

1. Store all required user data as well as the operating system settings of your system either on an external storage medium or via the network connection!
2. Switch off the supply voltage.

3. If operated with a UPS, wait until the control cabinet PC switches off automatically. The UPS LED on the connector panel of the control cabinet PC is red until the UPS switches off the internal power supply unit.
4. Remove all connectors.
5. Remove the safety screw of the hard disk carrier on the front panel of the control cabinet PC. Now the hard disk carrier including the hard disk(s) can be pulled out from the housing.

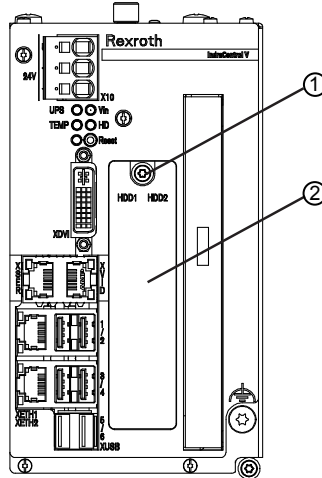

- ① Safety screw
- ② Hard disk carrier

Fig. 14-1: Position of the hard disk carrier and the fastening screw

6. The new hard disk parameters are identified automatically by the system. If the operating system does not boot automatically after switching on, do interrupt the power supply for at least ten seconds and restart.
7. After booting the control cabinet PC, restore the user data and the operating system settings for the normal operation.



If an SSD (Solid State Drive) is used, avoid defragmentation. Thus, the wear of the SSD reduces.

14.3 Fan

The fan is located on the top in the PC box.

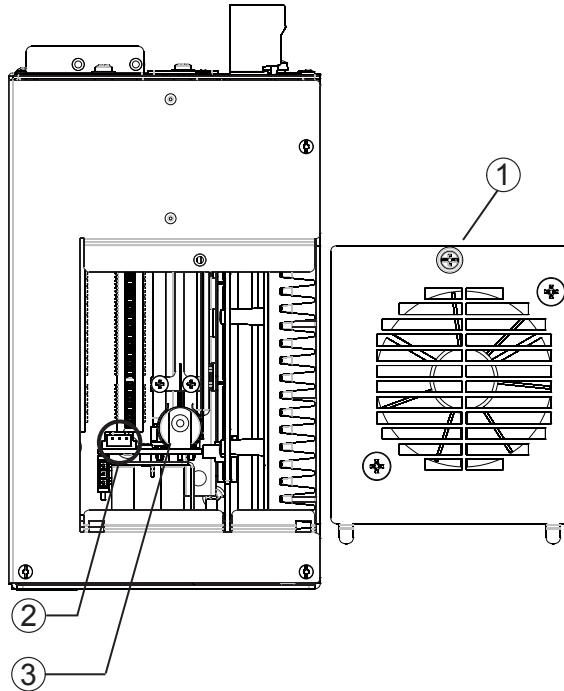

- ① Knurled screw of the fan tray
② Fan plug connection

- ③ CMOS battery

Fig. 14-2: Fan tray

⚠ CAUTION

Risk of injury by rotating fan impeller!

Do not touch the fan impeller with your hands and ensure that it does not come into contact with other objects.

Exchanging the fan

1. Disconnect the control cabinet PC.
2. Loosen the knurled screw.
3. Carefully remove the fan (including the fan cover).
4. Remove the supply cable of the fan from the board of the control cabinet PC.
5. Connect the supply cable of the new fan to the board of the control cabinet PC.
6. Install the new fan.

7. Tighten the knurled screw.



The connecting cable of the fan is connected to a PCB via a plug connection.

The cable may not be attached to anything and must **not be crimped**. The connecting cable of the fan has to be installed in an "upward-directed" loop while mounting the fan!

14.4 CMOS battery

The battery used to buffer remanent data (clock etc.) has a limited service life (see "[CMOS battery](#)" on page 7).

For the position of the lithium battery in the control cabinet PC, refer to [fig. 14-2 "Fan tray"](#) on page 47.



When using Intel® Core™ i7-3612QE, switch on the power supply of the device twice following a battery replacement to boot the device.

WARNING

Batteries can cause fire, explosions or chemical burn.

Do not load, remove, destroy, burn or heat batteries over 100 °C. Dispose old batteries immediately and properly. Keep away from children!

Battery exchange

1. Disconnect the control cabinet PC.
2. Loosen the knurled screw of the fan module, see [fig. 14-2 "Fan tray"](#) on page 47.
3. Carefully remove the fan (including the fan cover).
4. Remove the empty battery.
5. Insert the new battery, positive terminal to the bottom (observe the label on the battery!).
6. Insert the fan again.
7. Tighten the knurled screw.



The connecting cable of the fan is connected to a PCB via a plug connection.

The cable may not be attached to anything and must **not be crimped**. The connecting cable of the fan has to be installed in an "upward-directed" loop while mounting the fan!

15 Ordering information

For ordering information on accessories and spare parts, please refer to [chapter 5 "Spare parts, accessories and wear parts"](#) on page 5.

The control cabinet PC IndraControl VPB 40.3 is available in different variants according to the following type code.

Abbrev. column	1	2	3	4	5	6	7	8	9	10	1	2	3	4	5	6	7	8	9	20	1	2	3	4	5	6	7	8	9	30	1	2	3	4					
Example:	V	P	B	4	0	.	3	D	1	K	-	2	G	0	N	N	-	D	4	D	-	D	N	-	N	N	-	F	W										
Product	VPB..... = VPB																																						
Line	40..... = 40																																						
Series	3..... = 3																																						
Control panel interface	CDI..... = D1																																						
PC-Box¹⁾	1 slot, 1 x PCI..... = K																																						
	2 slots, 2 x PCI..... = L																																						
	4 slots, 4 x PCI..... = M																																						
	2 slots, 1 x PCI + 1 x PCIe..... = N																																						
	4 slots, 2 x PCI + 2 x PCIe..... = Q																																						
	4 slots, 4 x PCIe..... = R																																						
Memory capacity (RAM)^{2) 6)}	1024 MB..... = 1G0																																						
	2048 MB..... = 2G0																																						
	4096 MB..... = 4G0																																						
	8192 MB..... = 8G0																																						
Interface	Without special interface..... = NN																																						
System configuration⁵⁾	Celeron P4500, 1.86 GHz, 2 MB L2 Cache..... = C3																																						
	Core Duo L2400, 1.66 GHz, 2 MB Cache..... = D1																																						
	Core 2 Duo T7400, 2.16 GHz, 4 MB Cache..... = D2																																						
	Core i5-520M, 2.4 GHz, 3 MB L2 Cache..... = D4																																						
	Core i7-620M, 2.66 GHz, 4 MB L2 Cache..... = D5																																						
	Core i7-3612 QE, 2.1 GHz, 6 MB L2 Cache..... = D6																																						
Supply voltage	DC 24 V..... = D																																						
Hard disk (HD)³⁾	2.5", min. 160 GB..... = D																																						
	2.5", min. 160 GB (2 x HDD in Raid 1)..... = E																																						
	2.5", min. 32 GB, Solid State Disk (SSD)..... = F																																						
	2.5", min. 100 GB, Solid State Disk (SSD)..... = H																																						
	2.5", min. 500 GB..... = J																																						
	2.5", min. 192 GB (2 x SSD in Raid 1)..... = K																																						
Drive⁴⁾	Without..... = N																																						
	DVD±RW..... = E																																						
Other design	Without..... = NN																																						
Firmware and software	Denotes that firmware and software must be ordered as separate substitution..... = FW																																						

Note:

- 1) PC-Box "K" and "N" is only available with drive "N"
- 2) Memory capacity "1G0" is only available with system configuration "D1"
Memory capacity "2G0" is only available with system configuration "C3", "D2" and "D4"
Memory capacity "4G0" is only available with system configuration "D2", "D4" and "D5"
Memory capacity "8G0" is only available with system configuration "D6"
- 3) Hard disk 2E" is only available with system configuration "D1", "D2", "D4" or "D5"
Hard disk "K" is only available with system configuration "D4" and "D5"
- 4) Drive "E" is only available with PC-Box "L", "M", "Q" and "R"
- 5) System configuration "D4" is possible with memory capacity "2G0" and "4G0"
- 6) By the Memory capacity it is a minimum disclosure

Fig. 15-1: Type code of the control cabinet PC IndraControl VPB 40.3

16 Disposal

16.1 Return

For disposal, our products can be returned free of charge. However, the products must be free of remains like oil and grease or other impurities.

Furthermore, the products returned for disposal must not contain any undue foreign substances or components.

Send the products free of charge to the following address:

Bosch Rexroth AG
Electric Drives and Controls
Bürgermeister-Dr.-Nebel-Straße 2
97816 Lohr am Main, Germany

16.2 Packaging

The packaging material consists of cardboard, plastics, wood or styrofoam. Packaging material can be recycled anywhere.

For ecological reasons, please do not return empty packages.

16.3 Batteries and accumulators

Batteries and accumulators can be labelled with this symbol.



The symbol indicating "separate collection" for all batteries and accumulators is the crossed-out wheeled bin.

The end user within the EU is legally obligated to return used batteries. Outside the validity of the EU Directive 2006/66/EC keep the stipulated directives.

Used batteries can contain hazardous substances, which can harm the environment or the people's health when they are improperly stored or disposed of.

After use, the batteries or accumulators contained in Rexroth products have to be disposed of according to the country-specific collection system.

17 Service and support

Our worldwide service network provides an optimized and efficient support. Our experts offer you advice and assistance should you have any queries. You can contact us **24/7**.

Service Germany

Our technology-oriented Competence Center in Lohr, Germany, is responsible for all your service-related queries for electric drive and controls.

Contact the **Service Hotline** and **Service Helpdesk** under:

Phone: **+49 9352 40 5060**
Fax: **+49 9352 18 4941**
E-mail: service.svc@boschrexroth.de
Internet: <http://www.boschrexroth.com/>

Additional information on service, repair (e.g. delivery addresses) and training can be found on our internet sites.

Service worldwide

Outside Germany, please contact your local service office first. For hotline numbers, refer to the sales office addresses on the internet.

Preparing information

To be able to help you more quickly and efficiently, please have the following information ready:

- Detailed description of malfunction and circumstances
- Type plate specifications of the affected products, in particular type codes and serial numbers
- Your contact data (phone and fax number as well as your e-mail address)

Index

A

Accessories.....	5
Accumulators.....	51
Ambient conditions.....	8
ANSI Z535.6-2006.....	3

B

Batteries.....	51
BIOS settings.....	24
Buffer battery.....	48

C

Cables routing.....	20
CDI interfaces.....	18
CE marking.....	12
CMOS battery.....	7, 48
Commission.....	39
Complaints.....	2
Conductor cross-sections.....	16
Connecting 24 V supply to the control cabinet PC.....	33
Connecting cables for the CDI interface.....	6
Criticism.....	2
Customer Feedback.....	2

D

Declaration of conformity.....	12
Defragmentation.....	7
Device description.....	41
Dimensions	
Installation notes.....	20
Disposal.....	51
Documents, related.....	2

E

Electric connection.....	33
Error causes.....	43
Ethernet connection.....	17
Extension cards.....	19
External 24 V power supply unit....	5

F

Fan.....	46
Fans, service life.....	7

Feedback.....	2
---------------	---

H

Hard disk exchange.....	45
Hard disks, operating conditions....	7
Hazard warning.....	3
Helpdesk.....	51
Hotline.....	51
Housing dimensions.....	24
Housing distances for maintenance tasks.....	20

I

Installation notes.....	20
Installing extension cards.....	21
Intended use.....	4
Interfaces.....	14
CDI interfaces.....	18
DVI interface.....	17
Ethernet.....	17
USB interfaces.....	16

K

Keys.....	41
-----------	----

L

LAN assignment.....	17
LEDs	
Operating and error displays...	42

M

Maintenance	
CMOS battery.....	48
Extension cards.....	19
Fan.....	46
General information.....	44
Hard disk(s).....	45
Mounting.....	20

N

24 V power supply unit.....	5
-----------------------------	---

O

Operating and error displays.....	42
-----------------------------------	----

P		
PC voltage supply.....	15	
Product identification.....	2	
Purpose.....	1	
R		
RAID.....	42	
Recommendation for the mounting of CDI cables with long lengths in an interfer- ence-prone environment.....	36	
S		
24 V voltage supply.....	15	
Safety alert symbol.....	3	
Safety instructions.....	3	
Scope.....	1	
Scope of delivery.....	3	
Service hotline.....	51	
Signal words.....	3	
Solid State Drive Service life.....	7	
Spare parts.....	5	
SSD.....	7	
Standards.....	11	
Suggestions.....	2	
Support.....	51	
Symbols used.....	4	
T		
Target groups.....	1	
Technical data.....	10	
Standards used.....	11	
Tightening torques.....	45	
Troubleshooting.....	43	
Type plate.....	2	
U		
UL/CSA certified.....	13	
Uninterruptible power supply... 6, 33		
UPS.....	6, 33	
UPS with USB interface.....	34	
UPS without USB interface.....	36	
USB connecting cable.....	6	
USB connecting cable with in- creased noise immunity.....	7	
USB interfaces.....	16	
Use, intended.....	4	
W		
Warnings.....	3	
Wear parts.....	5, 7	
X		
X10.....	15	
XDVI interface.....	17	
XETH1.....	17	
XETH2.....	17	
XSER.....	18	
XUSB.....	16	
XVID.....	18	
Y		
Y-repeater.....	5	

Notes

Bosch Rexroth AG

Electric Drives and Controls

P.O. Box 13 57

97803 Lohr, Germany

Bgm.-Dr.-Nebel-Str. 2

97816 Lohr, Germany

Phone +49 9352 18 0

Fax +49 9352 18 8400

www.boschrexroth.com/electrics



R911336750