

Rexroth IndraControl S67 Digital Module

8 Inputs (8×M12)

Application Description
R911342194

Edition 03



Title Rexroth IndraControl S67
 Digital Module
 8 Inputs (8×M12)

Type of Documentation Application Description

Document Typecode DOK-CONTRL-S67DI8M12*8-AP03-EN-P

Internal File Reference RS-45e7daf8ceaad9bf0a6846a5004825c9-3-en-US-3

Change Record

Edition	Release Date	Notes
Edition 01	2013-10	First edition
Edition 02	2014-07	Supplements
Edition 03	2014-12	Corrections, supplements

Copyright

© Bosch Rexroth AG 2014
 This document, as well as the data, specifications and other information set forth in it, are the exclusive property of Bosch Rexroth AG. It may not be reproduced or given to third parties without its consent.

Liability

The specified data is intended for product description purposes only and shall not be deemed to be a guaranteed characteristic unless expressly stipulated in the contract. All rights are reserved with respect to the content of this documentation and the availability of the product.

Editorial Department

Compact Control KS (KaWa/MePe)

Table of Contents

	Page
1 About this Documentation.....	5
1.1 General information.....	5
1.2 Scope.....	5
1.3 Validity of the Documentation.....	6
1.4 Structuring the Documentation.....	7
1.5 Terms and Abbreviations.....	8
1.6 Customer feedback.....	8
2 Important Instructions on Use.....	9
2.1 Intended Use.....	9
2.1.1 Introduction.....	9
2.1.2 Use and Application Cases.....	9
2.2 Unintended Use.....	10
3 Using safety instructions.....	11
3.1 Safety instructions – Structure.....	11
3.2 Explaining signal words and safety alert symbol.....	11
3.3 Symbols used.....	12
4 Device Description.....	13
4.1 General information.....	13
4.2 Connections.....	13
4.3 Labeling Options and Mounting.....	14
4.4 Display Elements.....	15
4.5 Labeling and Symbols at Rear Side.....	16
4.6 Type Plate.....	17
4.7 Schematic Diagram	17
4.8 Dimensions.....	19
4.9 Technical Data.....	19
4.9.1 Device Data.....	19
4.9.2 Module Supply.....	20
4.9.3 Communication.....	20
4.9.4 Digital Inputs.....	20
4.9.5 Input Characteristic Curve.....	21
4.9.6 Electrical Isolation.....	21
4.9.7 Parameterizable Functions.....	21
4.9.8 Diagnostics I/O.....	21
4.9.9 Process Image.....	21
4.9.10 Displays.....	21
4.9.11 Standards and Approvals.....	22
5 Mounting the Module.....	23
5.1 General Information.....	23

Table of Contents

	Page
5.2	Mounting Notes..... 23
5.3	Required Tools and Accessories for Mounting..... 23
5.4	Direct Mounting to the System..... 24
5.5	Mounting on Carrier Rail (only with Bosch Rexroth Accessories)..... 24
5.5.1	Fastening Carrier Rail Adapter at the Module..... 24
5.5.2	Fastening the Module with Mounting Rail Adapter to a Mounting Rail..... 25
5.6	Mounting on Profile Rail (only with Bosch Rexroth Accessories)..... 26
5.6.1	Fastening the Profile Rail at the Module..... 26
5.6.2	Fastening the Module with Profile Adapter on Profile Rail..... 27
5.7	Replacing the Labeling Fields..... 27
5.8	Mounting the Spacer in Case of Compact Arrangement..... 28
6	Connecting Data and Supply Cables..... 31
6.1	Notes..... 31
6.2	Required Accessories..... 32
6.3	Connecting S-BUS..... 32
6.4	Connecting Supply Cables..... 33
6.5	Connecting Sensor Cables..... 35
7	Commissioning..... 37
7.1	General Information..... 37
8	Process Images..... 39
8.1	General Information..... 39
8.2	Input Data..... 39
8.3	Output Data..... 40
9	Parameterization..... 41
9.1	General Information..... 41
9.2	Diagnostic Overview..... 41
9.3	Input Parameters..... 41
9.4	Automatic Storage of System Parameters..... 42
9.5	Firmware Update..... 42
10	Diagnostics via LED Signals..... 43
10.1	General information..... 43
10.2	Operating Messages of the Module..... 43
11	Maintenance and Service..... 47
11.1	General Information..... 47
11.2	Replacing the Module..... 47
11.2.1	General Information..... 47
11.2.2	Disconnecting the Wiring..... 47
11.2.3	Removing the Field Bus Coupler from the System..... 47

Table of Contents

	Page
11.2.4 Removing the Field Bus Coupler from the Carrier Plate.....	47
11.2.5 Removing the Field Bus Coupler from the Profile Adapter.....	48
11.2.6 Connecting the Module.....	48
11.3 Disposal.....	48
12 Accessories.....	49
12.1 General information.....	49
12.2 Assembled S-BUS Cables.....	49
12.3 Ready-Made Supply Cables.....	51
12.4 Carrier Rail Adapter, Profile Adapter and Spacer.....	52
12.5 End Clamp.....	53
12.6 Protective caps.....	53
12.7 Module Labeling Strips.....	53
13 Appendix.....	55
13.1 Diagnostic Information.....	55
14 Service and support.....	57
Index.....	59

1 About this Documentation

1.1 General information

Read this chapter thoroughly before using the application description.

1.2 Scope

The present documentation applies to the digital input module S67-DI8-M12×8 of the IndraControl S67 series.

For other components of the IndraControl S67 series, the following documentations are available:

Document	Title	Parts number
Module-comprehensive		
Application Description	Rexroth IndraControl S67	R911329572
Application Description	Rexroth IndraControl S67 DTM Input and Output Modules	R911340954
Field bus coupler		
Application Description	Rexroth IndraControl S67 Ethernet/IP Coupler 8 Digital Inputs (M8)	R911329564
Application Description	Rexroth IndraControl S67 Profibus Coupler 8 Digital Inputs (M8)	R911329566
Application Description	Rexroth IndraControl S67 Profinet Coupler 8 Digital Inputs (M8)	R911329568
Application Description	Rexroth IndraControl S67 Sercos Coupler 8 Digital Inputs (M8)	R911338401
Modules		
Application Description	Rexroth IndraControl S67 Digital Module 8 Outputs – 0.5 A (8×M8)	R911329560
Application Description	Rexroth IndraControl S67 Digital Module 8 Outputs – 2.0 A (8×M8)	R911329562
Application Description	Rexroth IndraControl S67 Digital Module 8 Outputs – 0.5 A (4×M12)	R911329556
Application Description	Rexroth IndraControl S67 Digital Module 8 Outputs – 2.0 A (4×M12)	R911329558
Application Description	Rexroth IndraControl S67 Digital Module High Speed 8 Outputs – 0.1 A (4×M12)	R911342200
Application Description	Rexroth IndraControl S67 Digital Module 8 Outputs – 0.5 A (8×M12)	R911342196
Application Description	Rexroth IndraControl S67 Digital Module 8 Inputs (8×M8)	R911329552
Application Description	Rexroth IndraControl S67 Digital Module 8 Inputs (4×M12)	R911329550

About this Documentation

Document	Title	Parts number
Application Description	Rexroth IndraControl S67 Digital Module High Speed 8 Inputs (4×M12)	R911342198
Application Description	Rexroth IndraControl S67 Digital Module 8 Inputs/Outputs – 0.5 A (8×M8)	R911338695
Application Description	Rexroth IndraControl S67 Digital Module 8 Inputs/Outputs – 0.5 A (8×M12)	R911338697
Application Description	Rexroth IndraControl S67 Digital Module High Speed 4 Inputs/Outputs – 0.2 A (4×M12)	R911342202
Application Description	Rexroth IndraControl S67 Analog Module – 4 Inputs Voltage/Current (4×M12)	R911329544
Application Description	Rexroth IndraControl S67 Analog Module – 4 Inputs for the RTD (4×M12)	R911329542
Application Description	Rexroth IndraControl S67 Analog Module – 4 Inputs TC Temperature Sensors (4×M12)	R911338699
Application Description	Rexroth IndraControl S67 Analog Module – 4 Outputs Voltage/Current (4×M12)	R911329546
Application Description	Rexroth IndraControl S67 Universal Interface Module - 4 Inputs/Outputs – 0.5 A (M12)	R911339361
Application Description	Rexroth IndraControl S67 HTL Encoder, Counter Module 4 Digital Inputs/Outputs (4×M12)	R911342204
Application Description	Rexroth IndraControl S67 TTL, SSI Encoder Module 4 Digital Inputs/Outputs (4×M12)	R911342206
Application Description	Rexroth IndraControl S67 Power Distributor (6×M12)	R911329570

Tab. 1-1: Overview on the IndraControl S67 manuals

1.3 Validity of the Documentation

Overview on target groups and product phases

In the following illustration, the framed activities, product phases and target groups refer to the present documentation.

Example: In the product phase "Mounting (assembly/installation)", the target group "Mechanic/electrician" can execute the activity "Unpack, Mount and Install" using this documentation.

About this Documentation

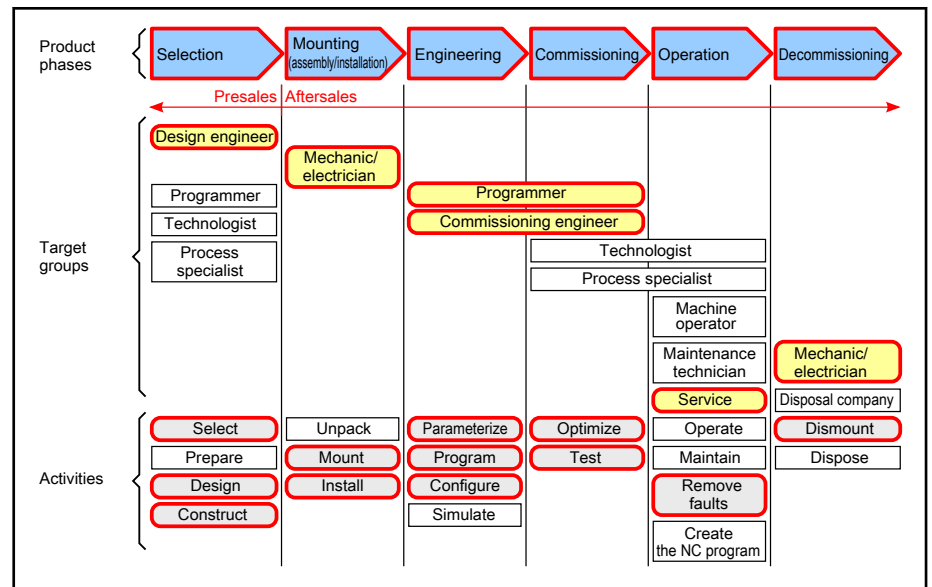

Fig. 1-1: Assigning this documentation to the target groups, product phases and target group activities

Purpose This documentation is intended for users commissioning a digital input module of type S67-DI8-M12×8. This documentation contains general information on the input module. Mounting and cabling of the input module are also described. The basic commissioning steps and the configuration of the IndraControl S67 station are then explained.

1.4 Structuring the Documentation

The first part of the documentation contains important information on the intended use as well as information on the safety instructions ([chapter 2 "Important Instructions on Use" on page 9](#) and [chapter 3 "Using safety instructions" on page 11](#)).

For a short overview on the structure and the functions of the digital input module, refer to [chapter 4 "Device Description" on page 13](#).

For information on mounting, refer to [chapter 5 "Mounting the Module" on page 23](#).

For information on data and supply cables, refer to [chapter 6 "Connecting Data and Supply Cables" on page 31](#).

For information on the commissioning, refer to [chapter 7 "Commissioning" on page 37](#).

For information on the process images of the digital input module, refer to [chapter 8 "Process Images" on page 39](#).

For the parameterization, refer to [chapter 9 "Parameterization" on page 41](#).

For the diagnostic options regarding the digital input module, refer to [chapter 10 "Diagnostics via LED Signals" on page 43](#).

For information on the module exchange, refer to [chapter 11 "Maintenance and Service" on page 47](#).

For information on the accessories for the digital input module, refer to [chapter 12 "Accessories" on page 49](#).

For diagnostic information, refer to [chapter 13 "Appendix" on page 55](#).

For information on the customer service help desk of Bosch Rexroth, refer to [chapter 14 "Service and support" on page 57](#).

About this Documentation

1.5 Terms and Abbreviations

Term	Explanation
CE	The CE marking (Conformité Européenne) is used by the manufacturer or EU importer according to the EU regulation 765/2008 and "indicates that the product complies with the applicable requirements specified in the Community harmonization legislation provided for its affixing"
UL	Underwriters Laboratories Inc., US organization for electrotechnical product certification
CSA	Canadian Standards Association. The CSA develops and maintains more than 3000 standards and regulations related to safety, design or performance
NEMA	National Electrical Manufacturers. The NEMA constitutes the representation of interests as well as the professional organization of the electrotechnical industry of North America
IndraWorks	Configuration and commissioning tool developed by Bosch Rexroth
EDS	Electronic Data Sheet (electronic data sheets to describe devices in the automation technology)
GSD	Device master data (contains characteristic communication features of a Profibus device as electronic device data sheet)
VPE	Packaging unit

Tab. 1-2: Terms and abbreviations

1.6 Customer feedback

Customer requests, comments or suggestions for improvement are of great importance to us. Please email your feedback on the documentations to Feedback.Documentation@boschrexroth.de. Directly insert comments in the electronic PDF document and send the PDF file to Bosch Rexroth.

2 Important Instructions on Use

2.1 Intended Use

2.1.1 Introduction

The Rexroth products represent state-of-the-art developments and manufacturing. The products are tested prior to delivery to ensure operating safety and reliability.

The products may only be used for the intended purpose. If the products are not used as intended, situations causing personal injury as well as material damage can occur.



Rexroth shall not be liable for damages resulting from unintended use. In such cases, the guarantee and the right to payment of damages resulting from unintended use are forfeited. The user alone carries all responsibility of the risks.

Before using Bosch Rexroth products, the following requirements must be met to ensure intended use of the products:

- Personnel who in any way, shape, form or use one of our products must first read and understand the relevant safety instructions and be familiar with the intended use of the products
- If the product takes the form of hardware, the products must remain in the original state, in other words, no structural changes are permitted. The decompilation of software products or the alteration of source codes is not permitted
- Do not install or operate damaged or faulty products
- Ensure that the products have been installed in the manner described in the relevant documentation

2.1.2 Use and Application Cases

The S67-DI8-M12×8 module is used to record digital field signals, e.g., from sensors, that are transmitted to a higher-level control (e.g. programmable coupler).

The S67-DI8-M12×8 module must not be used to control safety-related functions, e.g. EMERGENCY STOP mechanisms must not be operated with the S67-DI8-M12×8 module.

The S67-DI8-M12×8 module shall only be used in combination with a field bus coupler and I/O module of the IndraControl S67 series.

The S67-DI8-M12×8 module was developed for applications requiring IP 67 (NEMA type 6, 6P) degree of protection.



The S67-DI8-M12×8 module may only be used with the accessories and mounting parts listed in this documentation. Components that are not expressly mentioned must neither be attached nor connected. The same is valid for cables and lines.

Operation may only be carried out with the hardware component configurations and combinations that are expressly specified and with the software and firmware indicated and specified in the respective documentation and functional descriptions.

In case of non-compliance, the guarantee and warranty claims shall automatically expire.

Important Instructions on Use

The S67-DI8-M12×8 may only be operated under the mounting and installation conditions, the position, and the ambient conditions (temperature, degree of protection, humidity, EMC, etc.) specified in the related documentation.

2.2 Unintended Use

The use of the S67-DI8-M12×8 module in applications other than the modules specified or described in the documentation and the technical specifications is considered as "unintended".

The S67-DI8-M12×8 module must not be used if

- operation conditions which do not correspond to the specified ambient conditions Operation under water, extreme temperature fluctuations or extreme maximum temperatures is prohibited
- they are used in household devices or devices belonging to categories 1 to 7 and 10 specified in Appendix IA of the Directive 2002/96/EC ("WEEE")

3 Using safety instructions

3.1 Safety instructions – Structure

The safety instructions are structured as follows:

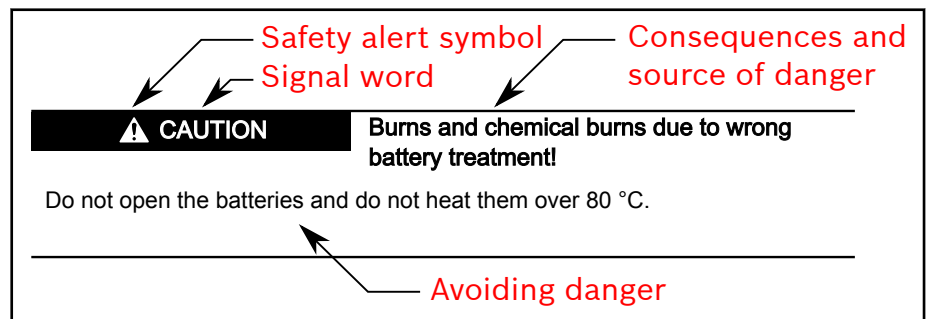

Fig. 3-1: Safety instructions – structure

3.2 Explaining signal words and safety alert symbol

The safety instructions in this documentation contain specific signal words (danger, warning, caution, notice) and, if necessary, a safety alert symbol (according to ANSI Z535.6-2006).

The signal word is used to draw attention to the safety instruction and also provides information on the severity of the hazard.

The safety alert symbol (a triangle with an exclamation point), which precedes the signal words danger, warning and caution is used to alert the reader to personal injury hazards.

⚠ DANGER

In the event of non-compliance with this safety instruction, death or serious injury **will** occur.

⚠ WARNING

In the event of non-compliance with this safety instruction, death or serious injury **will** occur.

⚠ CAUTION

In the event of non-compliance with this safety instruction, minor or moderate injury can occur.

NOTICE

In the event of non-compliance with this safety instruction, material damage can occur.

Using safety instructions

3.3 Symbols used

Pointers are displayed as follows:



This is a note.

Tips are displayed as follows:



This is a tip.

4 Device Description

4.1 General information

The positive-switching module S67-DI8-M12×8 analyzes sensors, encoders, switches and proximity switches. The module is provided with comprehensive parameterization options for the complete module. Module settings can be either made field bus-dependent via the device description file (e.g. GSD, GSDML) of a field bus or field bus-independent via an FDT/DTM frame application (e.g. IndraWorks).



For detailed information on the module parameterization using the field bus, refer to the corresponding documentation (e.g. "Rexroth IndraControl S67 Profibus Coupler 8 Digital Inputs (M8)").



For detailed information on the S67-DI8-M12×8 module properties, refer to [chapter 4.9 "Technical Data" on page 19](#).

4.2 Connections

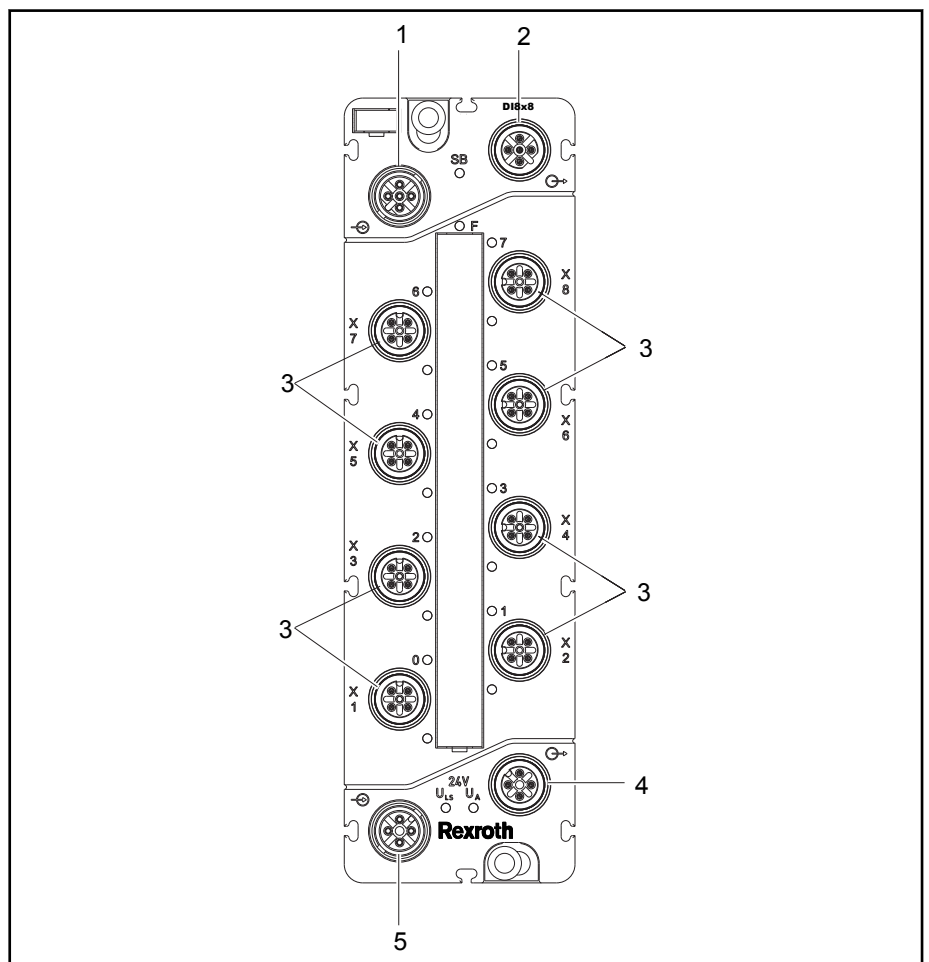

Fig. 4-1: ID of the module connections

Device Description

Position	Description	Function
1	S-BUS input M12 plug, B-coded	To transmit data of the previous IndraControl S67 component
2	S-BUS output M12 socket, B-coded	Forwarding the S-BUS to the next IndraControl S67 component or to the termination of the S-BUS
3	Digital inputs X1 – X8 M12 socket, A-coded	To connect digital sensor technology (e.g. initiators or limit switches)
4	Supply output M12 socket, A-coded	To provide logic, sensor and/or actuator supply for the following I/O module
5	Supply input M12 plug, A-coded	Feeding U_{LS} (logic and sensor voltage) and U_A (actuator supply)

Tab. 4-1: ID of the module connections

4.3 Labeling Options and Mounting

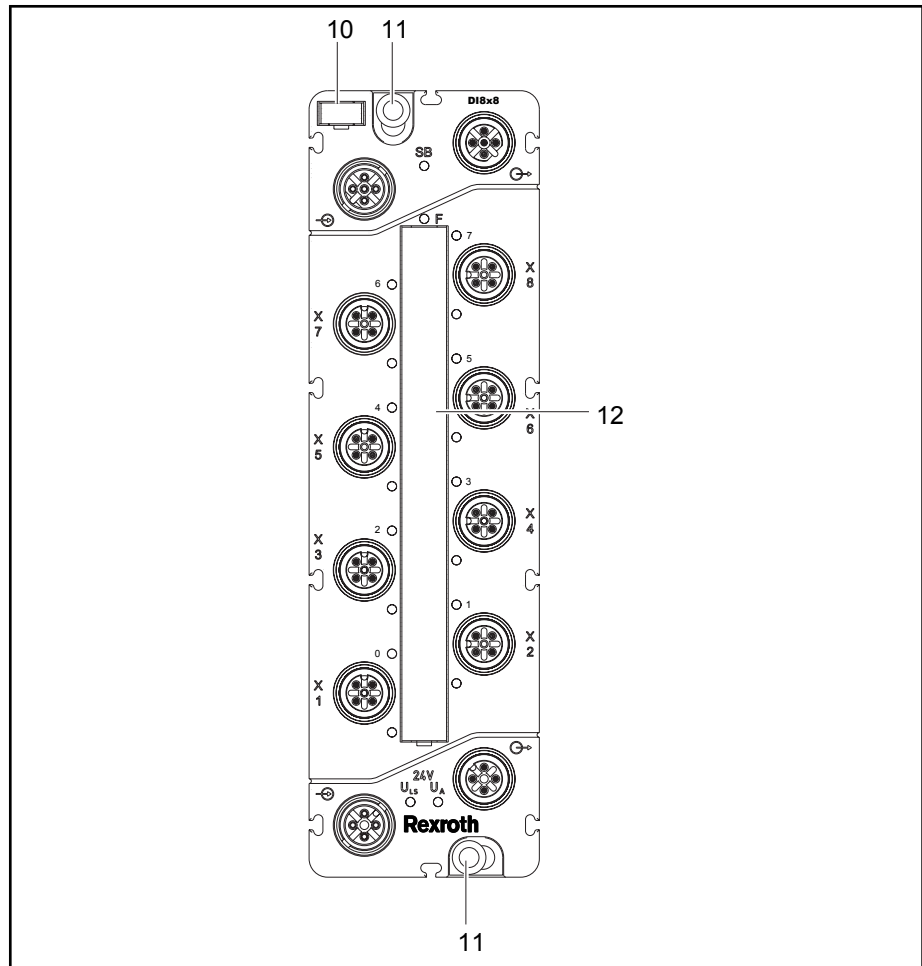

Fig. 4-2: Identifying options for labeling and mounting

Position	Description	Function
10	Module labeling plate	To identify the module in a field bus node
11	Mounting holes	Mounting and grounding the module using M4 screws
12	Labeling strips	To identify connections

Tab. 4-2: Identifying options for labeling and mounting

4.4 Display Elements

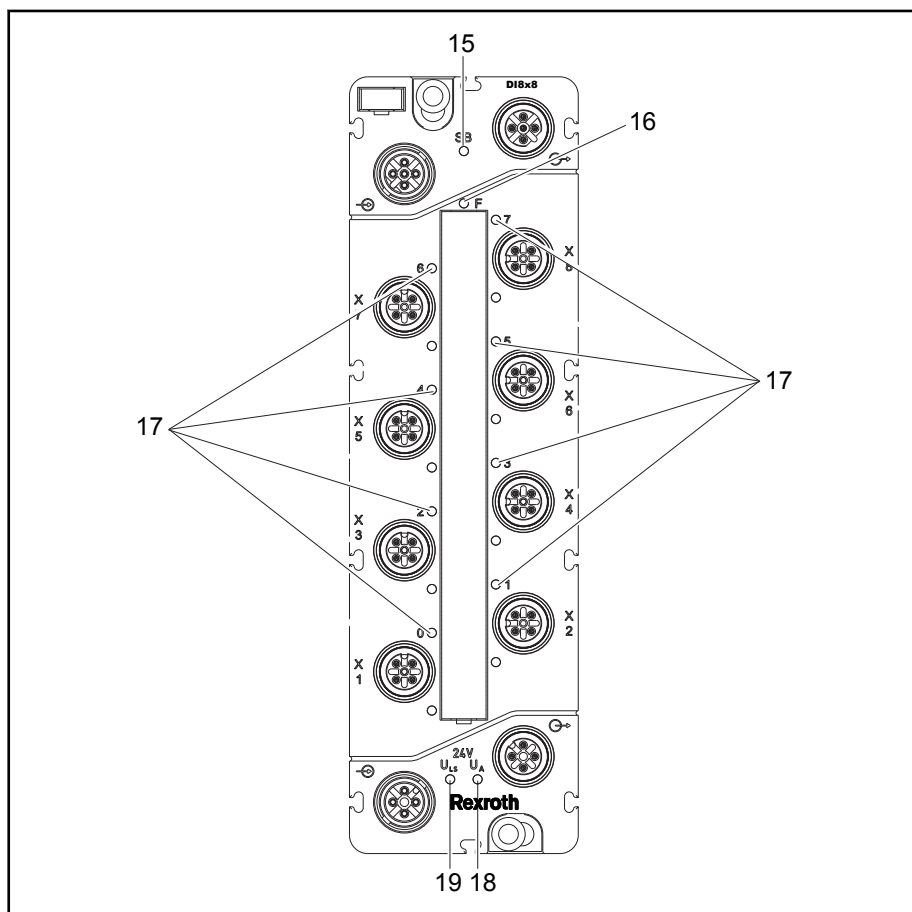

Fig. 4-3: Identifying module LEDs

Position	LED	Color	Meaning
15	SB	Green/red/ orange	S-BUS status
16	F	Red	Diagnostic information
17	0 to 7	Yellow	Input signal present
18	U _A	Green	Actuator supply present
19	U _{LS}	Green	Logic and sensor supply present

Tab. 4-3: Identifying module LEDs

For detailed information, refer to [chapter 10.2 "Operating Messages of the Module"](#) on page 43.

Device Description

4.5 Labeling and Symbols at Rear Side

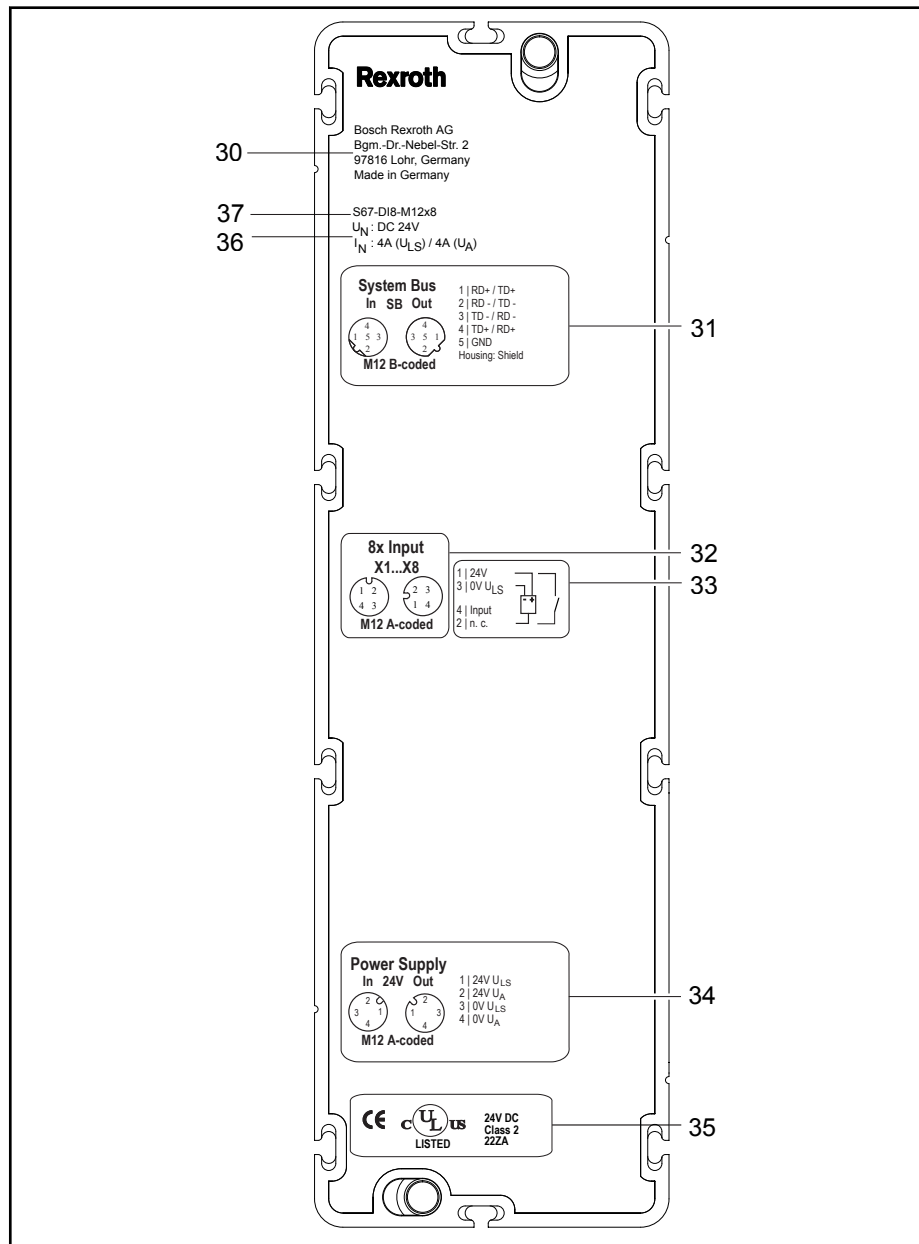

Fig. 4-4: Labeling and symbols

Position	Description
30	Manufacturer address
31	S-BUS pin assignment
32	Digital input pin assignment
33	Pin example
34	Pin assignment of supply input and output
35	Information on approval and CE mark

Position	Description
36	Power consumption and voltage specifications
37	Module name

Tab. 4-4: Labeling and symbols

4.6 Type Plate

A type plate is located on the side of the module. This type plate contains important information used for tracing in case of claims or complaints:

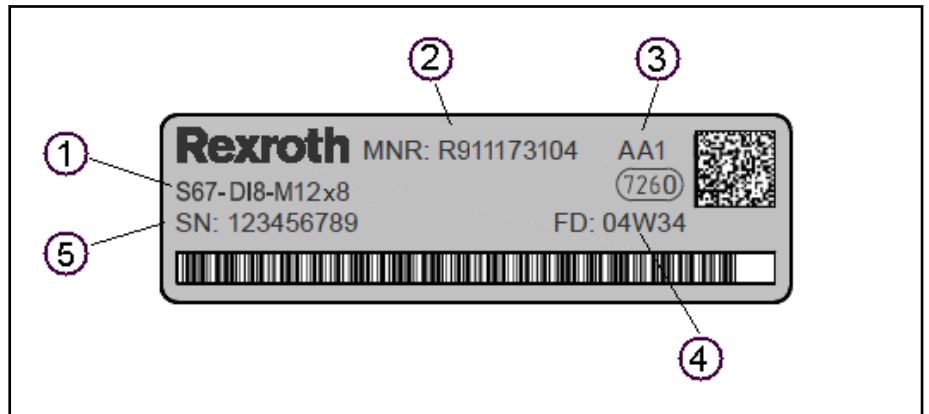

- ① Type code
- ② Parts number
- ③ Technical index
- ④ Date of manufacture
- ⑤ Serial number

Fig. 4-5: Type plate

4.7 Schematic Diagram

The following schematic diagram provides an overview on the power supply and the mode of operation of power supply connections as well as the digital module inputs (see also [chapter 6.4 "Connecting Supply Cables" on page 33](#) and [chapter 6.5 "Connecting Sensor Cables" on page 35](#)).

Note that the common field supply of the sensors is distributed to all module connections (pin 1 each).

Device Description

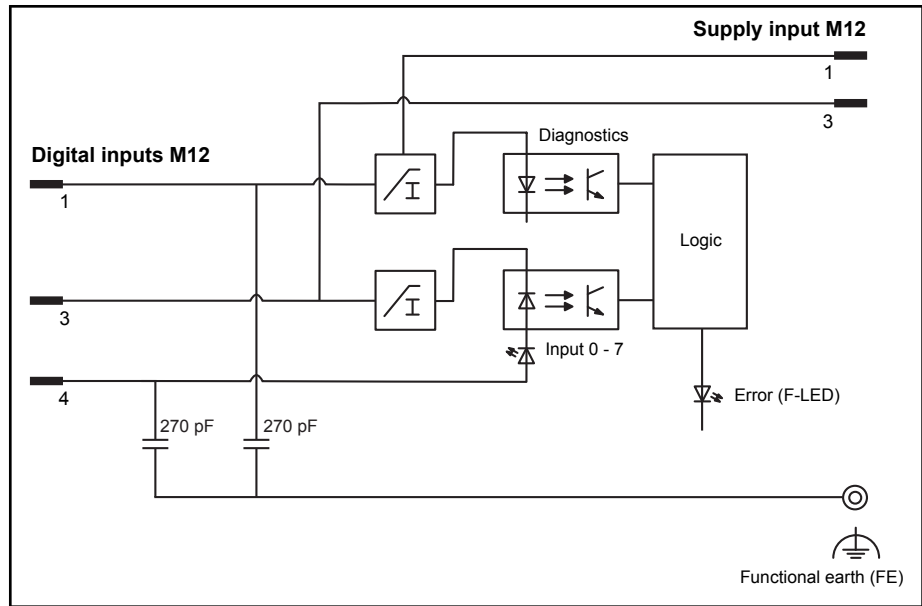

Fig. 4-6: Schematic diagram

4.8 Dimensions

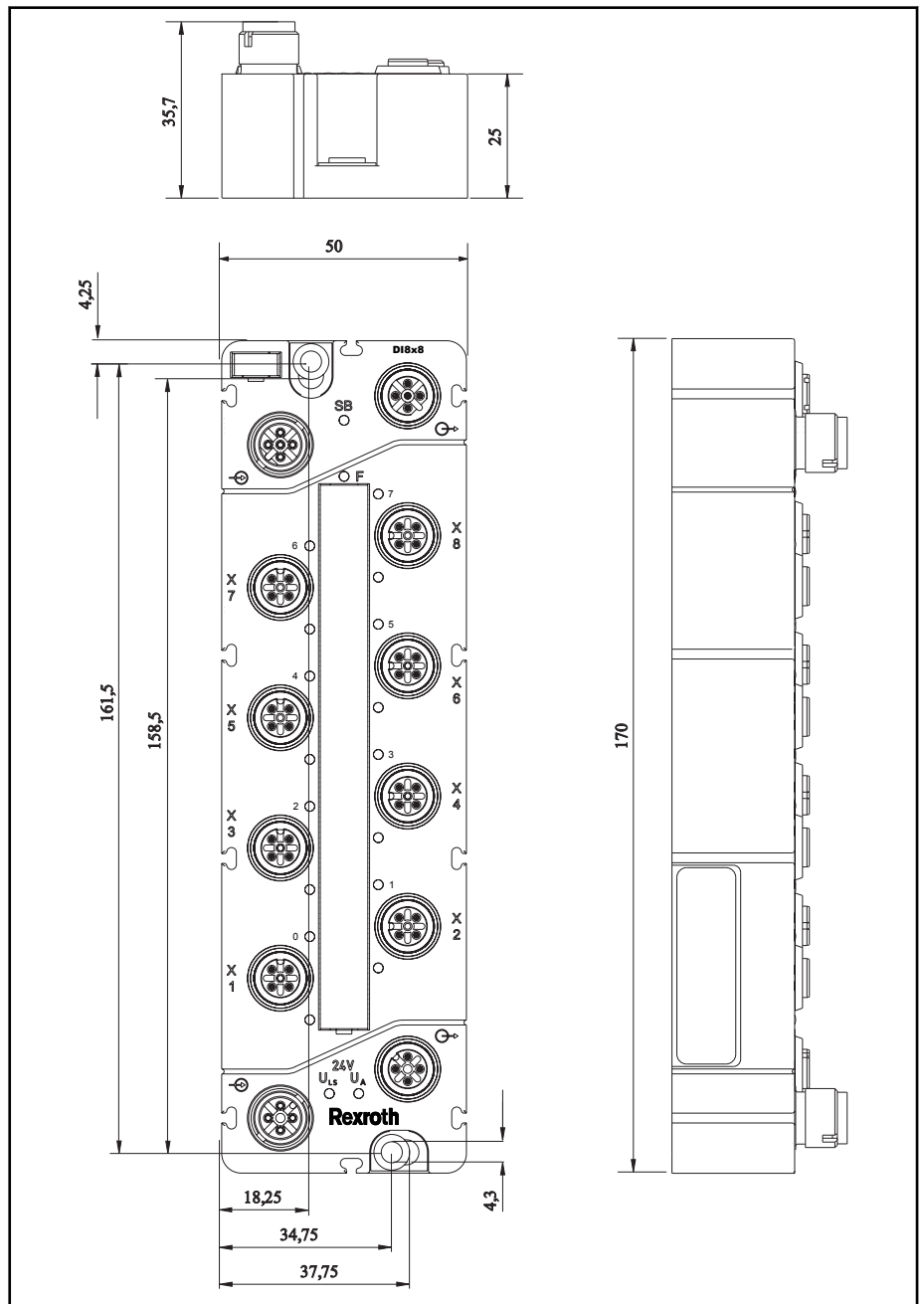

Fig. 4-7: Module dimensions in millimeters

4.9 Technical Data

4.9.1 Device Data

Dimensions (mm) W × H × D	50 × 170 × 35,7
Weight	Ca. 387 g

Tab. 4-5: Device data

Device Description

4.9.2 Module Supply

Connection type	M12 male connector, A-coded, 4-pin ^①
Current-carrying capacity of supply connections	Maximum: 8 A (U_{LS} : 4 A, U_A : 4 A)
Supply voltage	
Logic and sensor voltage U_{LS}	DC 24 V (-25 % ... +30 %)
Actuator voltage U_A ^②	DC 24 V (-25 % ... +30 %)
Supply current	
Logic and sensor current I_{LS}	Typically 40 mA + sensor technology (max. 400 mA)
Actuator current I_A	5 mA
	Reverse polarity protection for $U_{LS} + U_A$
Protection function	Reverse polarity protection for $U_{LS} + U_A$ Short-circuit protection of sensor supply

① Derating has to be complied with

② Also required to conduct supply voltage

Tab. 4-6: Module supply

4.9.3 Communication

S-BUS connection	Shielded M12 male connector, B-coded, 5-pin
------------------	---

Tab. 4-7: Communication

4.9.4 Digital Inputs

Number of inputs	8
Connection type	M12 male connector, A-coded, 4-pin
Termination technique	2- to 3-wire
Input filter	HW: $\leq 80 \mu\text{s}$ SW: Parameterizable
Input characteristic curve	Type 2, acc. to IEC 61131-2
Signal voltage (0)	-3 V ... +5 V DC
Signal voltage (1)	+11 V ... +30 V DC
Input circuit	High-side switching
Input voltage	24 V DC ($-3 \text{ V DC} < U_{IN} < +30 \text{ V DC}$)
Input current	Typically 7.3 mA
Connection of 2-wire BEROs	Maximum of 1.5 mA permissible quiescent current
Cable length, unshielded	$\leq 30 \text{ m}$
Incorrect connection of inputs	No effect

Tab. 4-8: Digital inputs

4.9.5 Input Characteristic Curve

Input voltage U_N	Typical input current
0 V	0 mA
5 V	2.4 mA
11 V	6.4 mA
24 V	7.3 mA
30 V	7.4 mA

Tab. 4-9: Input characteristic curve

4.9.6 Electrical Isolation

Channel - Channel	No
U_{LS} , U_A , S-BUS	DC 500 V each

Tab. 4-10: Electrical isolation

4.9.7 Parameterizable Functions

Input filter (per channel)	0.1/0.5/3/15/20 ms/filter off
(per module)	Diagnostics

Tab. 4-11: Parameterizable functions

4.9.8 Diagnostics I/O

Per module	Short circuit/overload field supply
Per module	Undervoltage (U_{LS} + U_A)

Tab. 4-12: Diagnostics I/O

4.9.9 Process Image

Process data width	1 byte data + status
--------------------	----------------------

Tab. 4-13: Process image



4.9.10 Displays

0 ... 7: Input signal status	LED (yellow)
F: Input error status	LED (red)
U_{LS} + U_A : Supply status	LED (green)
SB: S-BUS status	LED (green/red/orange)
Displays	Non-storing

Tab. 4-14: Displays

Device Description

4.9.11 Standards and Approvals

UL/CSA 	UL 508 (Industrial Control Equipment)
	C22.2 No. 14-95 (CSA)
	UL file no. E210730
Conformity marking 	CE

Tab. 4-15: Standards and approvals

5 Mounting the Module

5.1 General Information

The S67-DI8-M12×8 module can be fastened directly to the system using screws. It can also be mounted on a mounting rail using an adapter or fastened to a profile rail using a mounting profile.

For mounting on a flat surface, Bosch Rexroth offers spacers as mounting aid; the spacers can be inserted between the IndraControl S67 components. This helps by providing sufficient mounting distance for compact direct mounting, as well as eliminating gaps where dirt could accumulate. A cable tie can be fastened through each of two eyebolts in the spacer, which together serve as strain relieve from the sensor cables.

5.2 Mounting Notes

The following information shall always be observed:

- Disconnect the power supply from the system before starting the installation.
- The maximum drilling hole diameter for the fastening holes of the field bus coupler must not exceed 4 mm. Otherwise, there may be no full contact with the PE socket of the S67-DI8-M12×8 module and correct shielding is not possible.
- To protect the module from tensile forces that may arise, do not bridge spaces with the S67-DI8-M12×8 module
- Screw the S67-DI8-M12×8 module down only on flat contact surfaces to protect it from warping
- Ensure that the connectors are not soiled during mounting. Dirt damages the contacts, which can cause corrosion in these areas
- To avoid damaging the S67-DI8-M12×8 module, do not mount it in shear areas of moving devices.
- Provide sufficient potential equalization in the system
- Use all fastening holes to mount the S67-DI8-M12×8 module to the system so that all FE connections lie on a ground potential

5.3 Required Tools and Accessories for Mounting

Depending on the mounting type, the following tools are required for installation:

- A screwdriver for M4 fastening screws
- Drilling machine to pre-drill the fastening holes for mounting on the system for the S67-DI8-M12×8 module and, if required for the imperforated mounting rails
- M4 thread cutter (bottoming tap or hand tap set)

The Bosch Rexroth accessories listed below are required for mounting. The associated order numbers are listed in [chapter 12 "Accessories" on page 49](#).

- Mounting rail adapter including fastening screws and perforated or non-perforated mounting rails (TS 35 x 7.5 rail) according to EN 60715
or
- Profile adapter, including fastening screws

Mounting the Module

- Spacer (optional)

Two M4×12 screws are required for direct mounting of the S67-DI8-M12×8 module. The length of the screw shaft is to be selected according to the fastening type.

Bore dimensions

When fastening the IndraControl S67 component without a threaded hole, the clearance hole must not be wider than 4 mm to ensure a safe contact of the FE (functional earth ground) connections.

5.4 Direct Mounting to the System

Mount the S67-DI8-M12×8 module without using Bosch Rexroth accessories directly on a flat surface of the system. For direct mounting of the module proceed as follows:

1. Disconnect the power supply from those devices on which you wish to mount the S67-DI8-M12×8 module.
2. Mark the drilling holes. For this, use the drilling template printed on the packaging. Alternatively, hold the S67-DI8-M12×8 module in the desired position and mark the drill holes. Ensure that there is sufficient space around the IndraControl S67 series component so that all cables can be connected without problems.



We recommend the use of Bosch Rexroth spacers for compact direct mounting. If these spacers are used, the additional distance from the second IndraControl S67 component must be complied with (see [chapter 5.8 "Mounting the Spacer in Case of Compact Arrangement"](#) on page 28).

3. Fasten the S67-DI8-M12×8 module with the M4×12 screws via the two fastening holes.

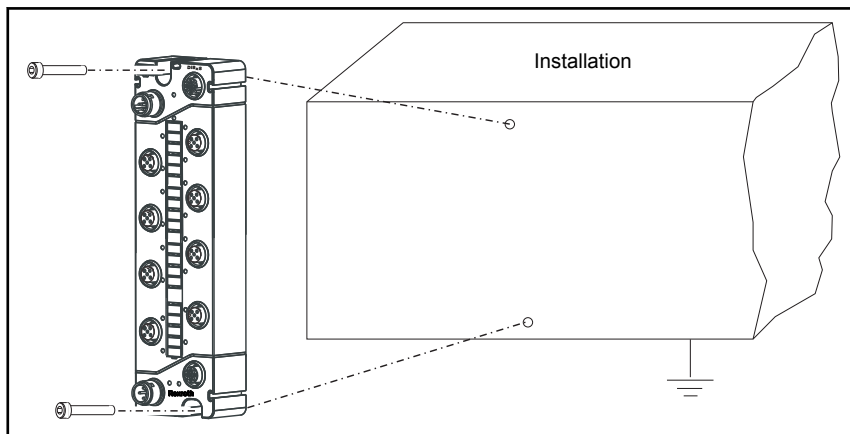

Fig. 5-1: Mounting the module at a grounded frame of the system or another earth connection point

5.5 Mounting on Carrier Rail (only with Bosch Rexroth Accessories)

5.5.1 Fastening Carrier Rail Adapter at the Module

A mounting rail adapter is required to mount the S67-DI8-M12×8 module on mounting rails.

Mounting the Module

Screw together the S67-DI8-M12×8 module and the mounting rail adapter using the M4 threaded screws provided, as shown in the figure below.

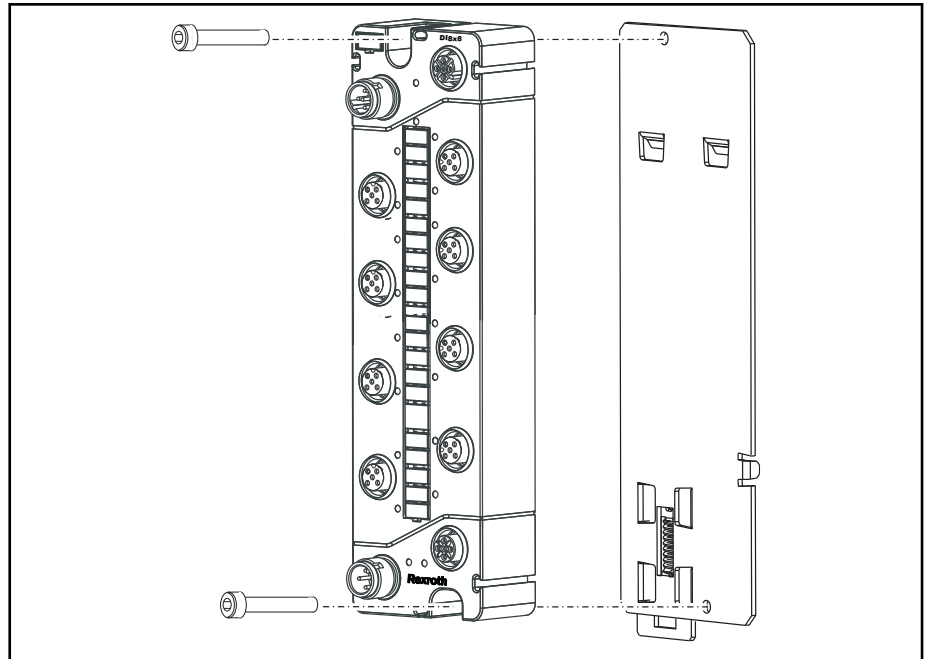

Fig. 5-2: Mounting on the mounting rail adapter

5.5.2 Fastening the Module with Mounting Rail Adapter to a Mounting Rail

In order to keep a clear representation, the mounting rail adapter in the figure below is shown without the S67-DI8-M12×8 module.

When mounting the S67-DI8-M12×8 module to a mounting rail (35 × 7.5 rail) using a mounting rail adapter, proceed as follows:

1. Disconnect the power supply from those devices on which you wish to mount the S67-DI8-M12×8 module.
2. Position the S67-DI8-M12×8 module onto the edge of the mounting rail (51) with the two notches (50).
3. Press the bottom side against the lower mounting rail edge until the latch (52) locks in place.



For vertical mounting of the mounting rail or when vibrations or shock occur, the end clamp SUP-M01 or SUP-M01-AL are to be used for stabilization (see [chapter 12.5 "End Clamp" on page 53](#)).

Mounting the Module

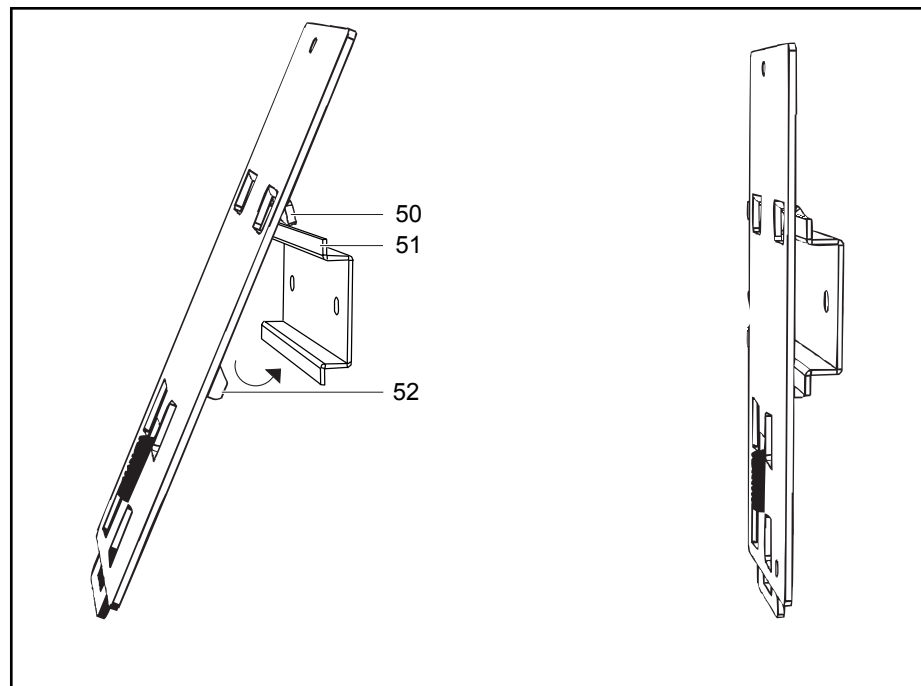

Fig. 5-3: Mounting the mounting rail adapter

5.6 Mounting on Profile Rail (only with Bosch Rexroth Accessories)

5.6.1 Fastening the Profile Rail at the Module

In addition to the attachment using a mounting rail adapter, the S67-DI8-M12×8 module can be fastened to a profile rail using a profile adapter and nuts. It is required that the system supports this attachment type. The nuts are not included in the scope of delivery.

Screw together the S67-DI8-M12×8 module and the profile adapter using the M4 threaded screws provided, as shown in the figure below.

Mounting the Module

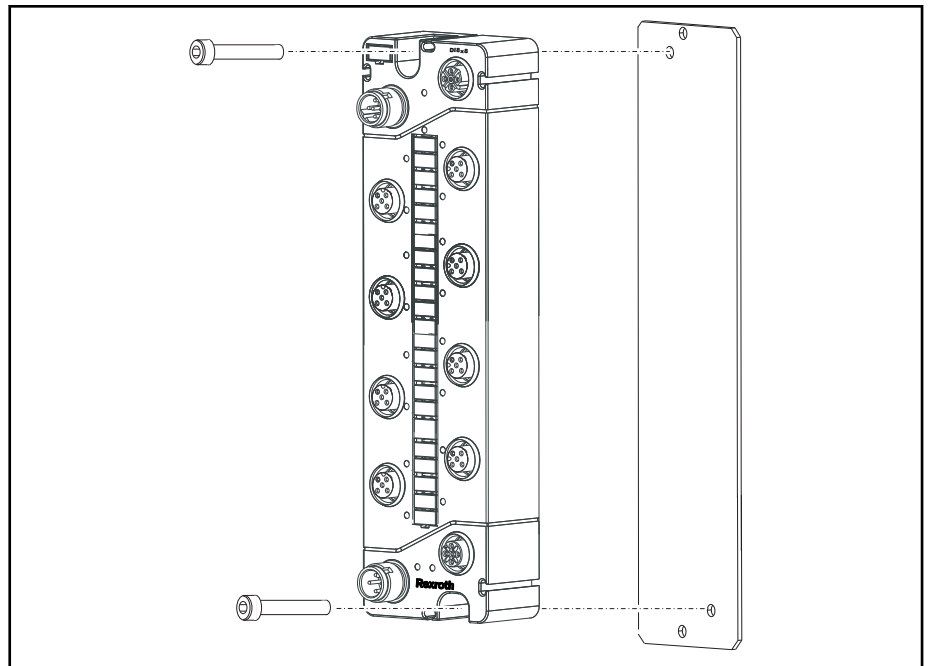

Fig. 5-4: Attaching to a profile adapter

5.6.2 Fastening the Module with Profile Adapter on Profile Rail

To fasten the S67-DI8-M12×8 module to a profile rail of the system, two nuts are required with one screw each (length of screw threads must be compatible with the system).

1. Disconnect the power supply from those devices on which you wish to mount the S67-DI8-M12×8 module.
2. Insert the two screws into the holes above and beneath the fastened S67-DI8-M12×8 module on the profile adapter.
3. Fasten an appropriate nut on each of these screws.
4. Insert the profile adapter with the attached S67-DI8-M12×8 module into the profile rail of the system. Position the profile adapter and tighten the screws.

5.7 Replacing the Labeling Fields

The module labeling card and labeling strip are attached ex works. The protective cover is to be removed when labeling the labeling strip. Proceed as follows:

1. Press the slot screwdriver (maximum slot width: 3 mm) into the small opening under the labeling strip cover (12) and lever the cover up.
2. Remove the labeling strip cover.
3. Label the labeling strip with a waterproof pen.
4. Reinsert the labeling strip cover and press it firmly in place.

If the module labeling card (10) is to be replaced, proceed in accordance with the step sequence described previously. New module labeling cards are available from Bosch Rexroth as accessories.

Mounting the Module

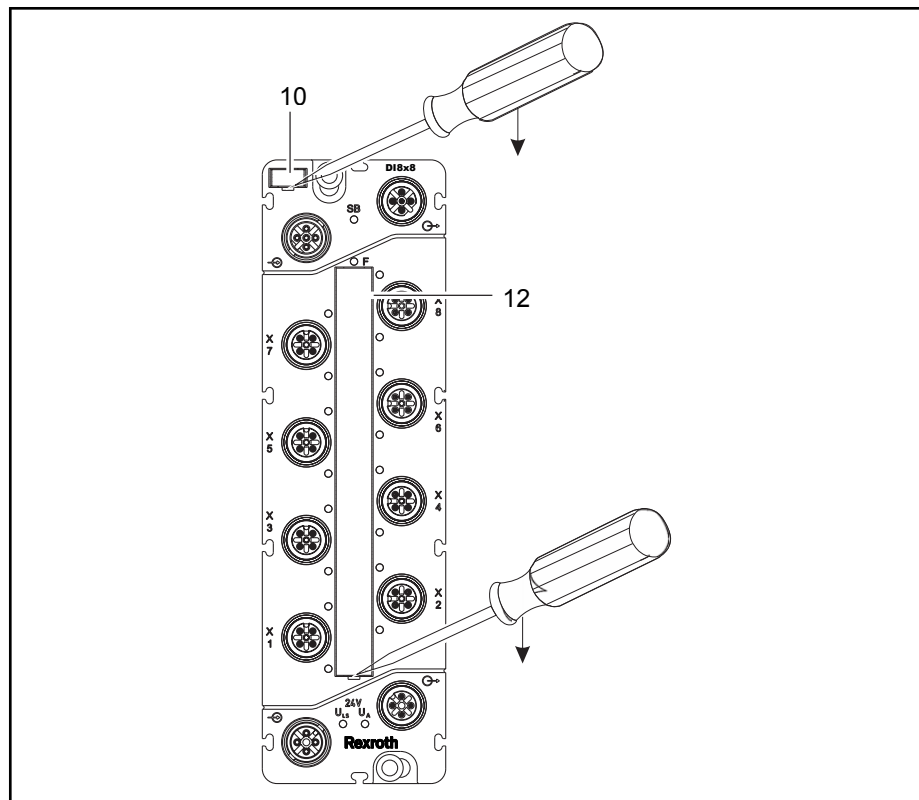

Fig. 5-5: Replacing the labeling fields

5.8 Mounting the Spacer in Case of Compact Arrangement

By using the spacer, a sufficient mounting distance can be achieved when directly mounting the IndraControl S67 components, and gaps can be eliminated where otherwise dirt and other substances could accumulate. In addition, it is possible to optimize the cable routing of the sensors. For this purpose, two fastening lugs each are included on the spacer for cable ties.

1. Disconnect the power supply from those devices on which you wish to mount the S67-DI8-M12×8 module.
2. To prevent the IndraControl S67 components from falling out when it is mounted overhead, the spacer can only be moved in the designated openings of the S67-DI8-M12×8 module from below. To bind both components, place the S67-DI8-M12×8 module on the spacer for this reason or push the spacer from the bottom into the S67-DI8-M12×8 module.
3. Fasten the attached components on a flat surface by fastening the S67-DI8-M12×8 module to the grounded border of your system or to another grounding point with two M4 screws via the mounting holes.

Mounting the Module

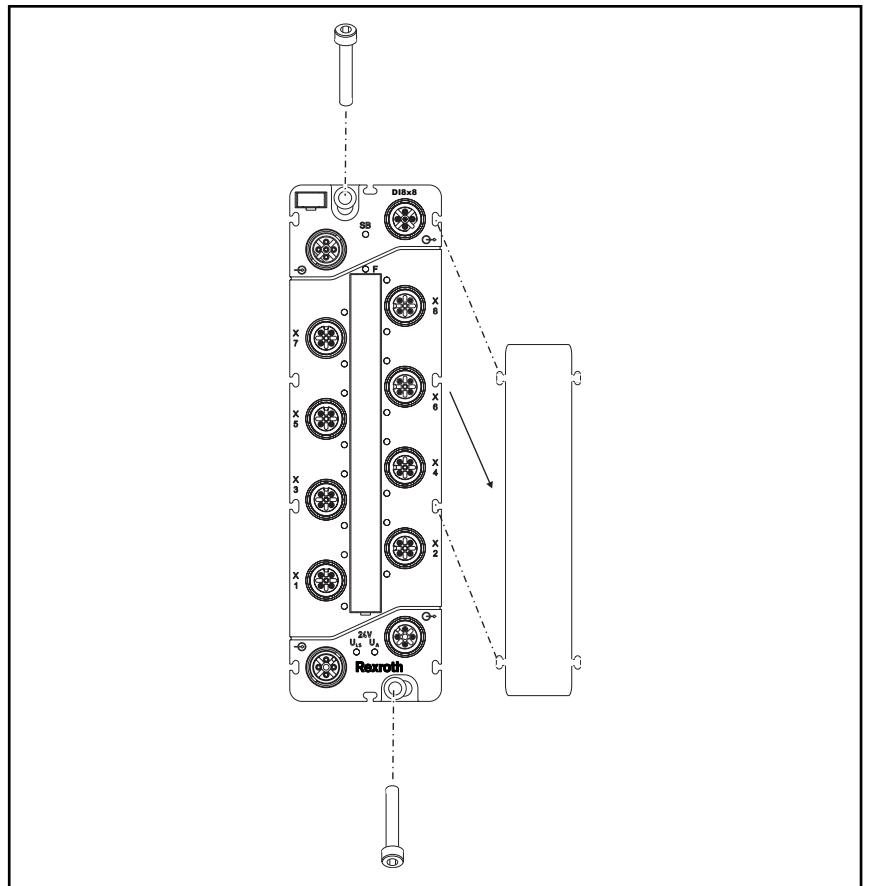

Fig. 5-6: Attaching a spacer on a module

4. When attaching further IndraControl S67 components, only one IndraControl S67 component connected with a spacer can be attached and screwed to the preceding component due to the mounting direction. The last IndraControl S67 component is fastened without a spacer.

Mounting the Module

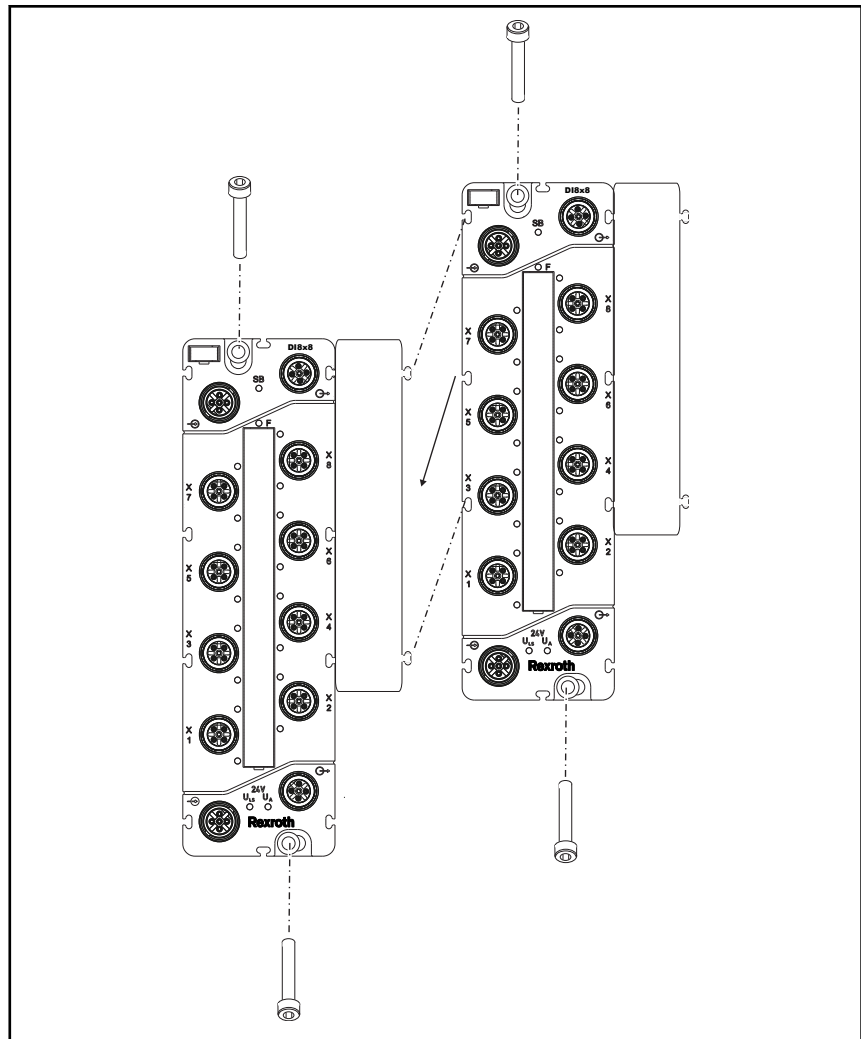

Fig. 5-7: Attaching a further module with spacer

6 Connecting Data and Supply Cables

6.1 Notes

⚠ WARNING**Voltage!**

Operate IndraControl S67 components exclusively with DC 24 V PELV (protective extra-low voltage) or SELV (safety extra-low voltage) voltage sources. Non-compliance can result in electric shock.

NOTICE**Highest current carrying capacity of supply contacts is 4 A!**

Observe the maximum current carrying capacity per supply line (U_{LS} , U_A) as well as the total current consumption for all IndraControl S67 components. Both values must not exceed 4 A, as an increase in current causes the contacts to overheat and damages the IndraControl S67 components.

NOTICE**Open connections!**

If connections are not closed with protective caps, liquid or dirt can enter and thus destroy the S67-DI8-M12×8 module. Protect all connections that are not required with protective caps to comply with the degree of protection IP 67.

- The male connectors must be disconnected from the power supply before screws are tightened.
- Tighten the male connectors only by hand. Using mechanical tools can cause the threads to strip. In this case, the S67-DI8-M12×8 module has to be replaced

Tightening torques for male connectors are:

- Sensor connections, M12: 0.6 Nm
- S-BUS and supply connections, M12: 0.6 Nm
- Check the exact positioning (coding) between plug and socket
- Use only ready-made Bosch Rexroth system cables to transmit the power supply and for the S-BUS. This achieves the specified characteristic values of technical data.
- Keep sufficient distance between all cables and electromagnetic interference sources to achieve a high noise immunity of the IndraControl S67 system against electromagnetic emissions.
- Note the minimum bending radius of Bosch Rexroth system cables (see [chapter 12.2 "Assembled S-BUS Cables" on page 49](#))
- When laying the cables, ensure not to lay cables in shear areas of moving machine parts
- Ensure the correct layout of the potential equalization
- Do not use drop stubs, as increased line reflections and signal distortions are caused! This worsens the transmission properties significantly.

Connecting Data and Supply Cables

6.2 Required Accessories

The Bosch Rexroth accessory components listed below are required to connect data and supply cables. The corresponding ordering numbers are listed in [chapter 12 "Accessories" on page 49](#).

- S-BUS terminator M12, degree of protection IP 67
- S-BUS and supply cables ready-made at both ends, IP 67
- Protective caps

6.3 Connecting S-BUS

The S-BUS is used for communication between a field bus coupler and the connected IndraControl S67 components.

Prerequisite:

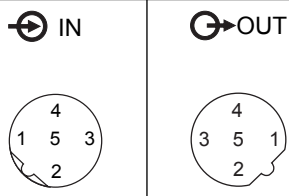
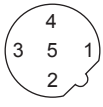

- A Bosch Rexroth S-BUS cable ready-made at both ends is available. It is required for an optimum signal transmission
- The S-BUS terminator is available. It is necessary for communication

The following table outlines the assignment of the S-BUS connections:

Connection		Contact	Description	
			IN	OUT
		1	RD+	TD+
		2	RD-	TD-
		3	TD-	RD-
		4	TD+	RD+
		5	0 V DC	
Connection thread		Shielded		

Tab. 6-1: S-BUS: Pin assignment

To connect the S-BUS cable to the field bus coupler and to the modules, proceed as follows:

1. Disconnect the power supply from those devices the S67-DI8-M12×8 module is mounted to.
2. Connect the S-BUS cable (S1) to the OUT connections  (3) of the field bus coupler and the IN connections  (1) of the S67-DI8-M12×8 module. For example, if two modules are connected to the field bus coupler, connect the S-BUS cables (S1, S2) to the associated IN and OUT connections as shown in the following figure.
3. Tighten the plugs and sockets using the knurled-head screws.
4. Attach the S-BUS terminator (T) to the last module and tighten the S-BUS terminator (as shown in the figure).

Connecting Data and Supply Cables

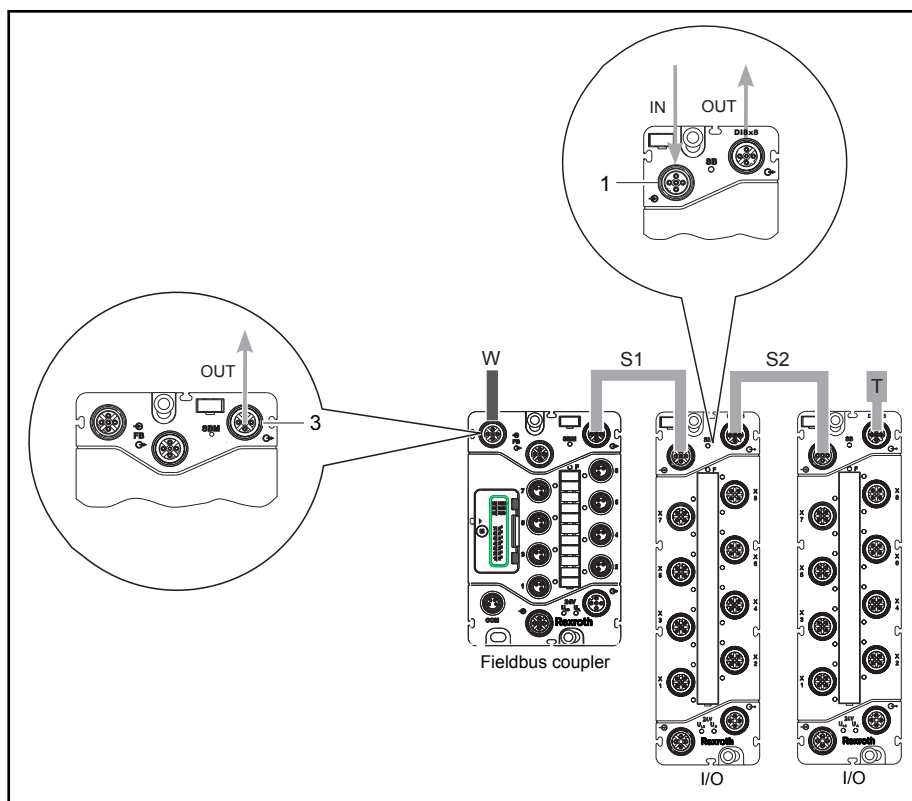

Fig. 6-1: S-BUS connected to field bus coupler and I/O modules

6.4 Connecting Supply Cables

The supply cable supplies the S67-DI8-M12×8 module.

Prerequisite:

A Bosch Rexroth supply cable ready-made at both ends is available (K1 and K2 in fig. 6-3 "Supply cable connected to field bus coupler and I/O modules" on page 35).

The following table outlines the assignment of the supply connections:

Connection	Contact	Description
	1	24 V DC U _{LS}
	2	24 V DC U _A
	3	0 V U _{LS}
	4	0 V U _A

Tab. 6-2: Supply connection: Pin assignment

Contact assignment of the supply cable ready-made on one end (view on socket):

Connecting Data and Supply Cables

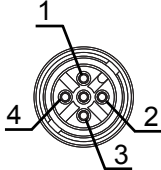
Connection	Contact	Description	Cable strand color
	1	24 V DC U_{LS}	Brown
	2	24 V DC U_A	White
	3	0 V U_{LS}	Blue
	4	0 V U_A	Black

Tab. 6-3: Supply cable ready-made on one end: Contact assignment

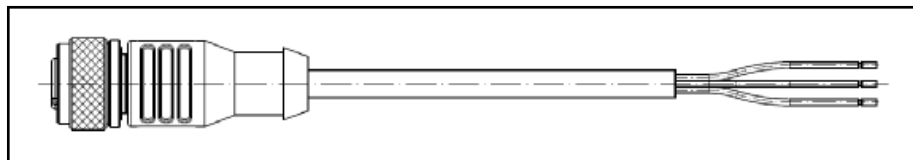

Fig. 6-2: Supply cable ready-made on one end

NOTICE

Highest current carrying capacity of supply contacts is 4 A!

Observe the maximum current carrying capacity per supply line (U_{LS} , U_A) as well as the total current consumption for all IndraControl S67 components. Both values must not exceed 4 A, as an increase in current causes the contacts to overheat and damages the IndraControl S67 components.

To connect the supply cable to the field bus coupler and to the modules, proceed as follows:

1. Disconnect the power supply from those devices the S67-DI8-M12×8 module is mounted to.
2. Connect the supply voltage transmission cable (K1) to the OUT connections \ominus (9) of the field bus coupler and the IN connections \oplus (5) of the S67-DI8-M12×8 module. For example, if two modules are connected to the field bus coupler, connect the supply voltage transmission cable (K1, K2) to the associated IN and OUT connections as shown in the following figure.
3. Tighten the plugs and sockets using the knurled-head screws.
4. Screw a protective cap on all unused connections to comply with the degree of protection IP 67.

For information on the supply voltage cable connection (K0) to the IN input \oplus (6) of a field bus coupler, refer to the corresponding application descriptions of the field bus couplers.

Connecting Data and Supply Cables

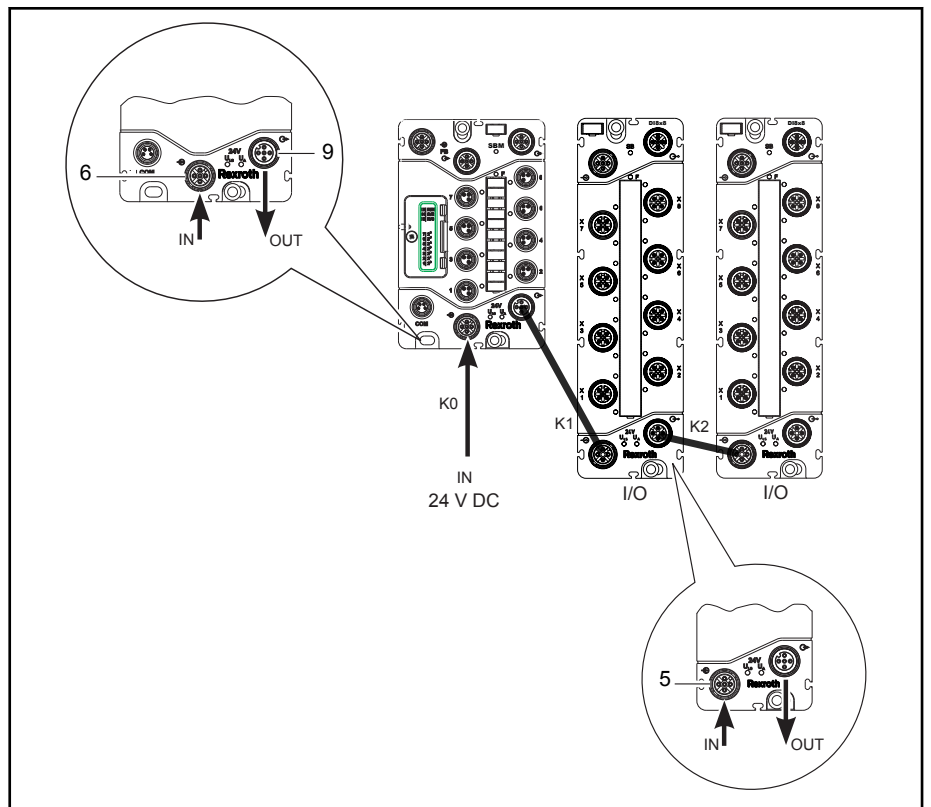

Fig. 6-3: Supply cable connected to field bus coupler and I/O modules

6.5 Connecting Sensor Cables

The sensor cables supply the connected sensors and transfer the sensor signals.

If ready-made cables are not used, ensure that an M12 connector with the degree of protection IP 67 is connected to the cables. The following table outlines the assignment of the sensor connections:

Connection		Contact assignment
IN X1, X3, X5, X7	IN X2, X4, X6, X8	1: 24 V 3: 0 V U _{LS} 4: Input

Tab. 6-4: Digital inputs: Pin assignment

NOTICE

Highest current carrying capacity of supply contacts is 4 A!

Ensure that the sensors are supplied from the U_{LS} supply line. The current consumption of the sensor has to be considered when determining the current power demand for the U_{LSA} supply line.

Connecting Data and Supply Cables

NOTICE

The current consumption of the sensor must not exceed 400 mA!

Note that the power consumption of all connected sensors must not exceed 400 mA. The power can be freely distributed among the existing connections.

To connect the sensors to the digital inputs (X1 – X8), proceed as follows:

1. Disconnect the power supply from those devices the S67-DI8-M12×8 module is mounted to.
2. Connect the plug of the sensor cable with the socket of a digital input (3) of the S67-DI8-M12×8 module and tighten the plug using a knurled-head screw.
3. Screw a protective cap on all unused connections to comply with the degree of protection IP 67.

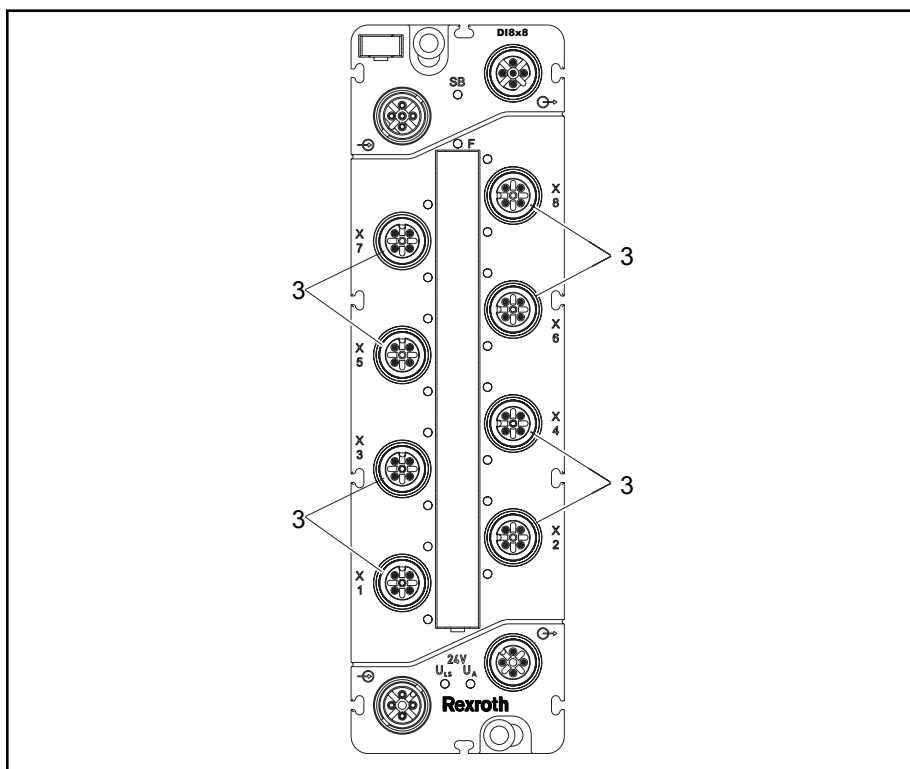

Fig. 6-4: Digital inputs

7 Commissioning

7.1 General Information

NOTICE

Exposed connections!

If connections have not been closed with protective caps, liquid or dirt can penetrate the S67-DI8-M12×8 module and destroy it. Protect all non-required connection with protective caps to comply with protection class IP 67.

Before starting up the IndraControl 767 station, ensure that

- a field bus coupler of the IndraControl S67 series is used¹⁾ and that the S67-DI8-M12×8 module is assembled correctly
- all required supply, sensor or actuator and S-BUS connections as well as the S-BUS connection is screwed tightly at the provided connections (see [chapter 6 "Connecting Data and Supply Cables" on page 31](#))
- and a suitable potential equalization has been executed at the system
- the shielding is correct

¹⁾ Refer to the application descriptions of the field bus couplers (IndraControl S67)

8 Process Images

8.1 General Information

The process images of the module contained in the following chapters describe the data position on the S-BUS. The field bus coupler application manual describes the conversion of the S-BUS process images to the respective field bus coupler process images.

The process image is divided into two areas: An area for output data and an area for input data. The process image can contain process data with or without diagnostic information, depending on whether the transmission of the synchronous¹⁾ diagnostic information has been activated. The diagnostic information can only be activated by means of a field bus coupler as the coupler supports the function of the synchronous diagnostic (e.g. S67-PB-BK-DI8-M8). Detailed information about activating the transmission of diagnostic information is contained in the application manual of the field bus coupler in the device description file chapter.



Synchronous diagnostics is disabled in the module in its delivery status.

Detailed information can be found starting in [chapter 9 "Parameterization"](#) on page 41.



Field supply diagnostics "short-circuit/overload" depend on the field supply switching status. A short circuit or an overload can only be diagnosed if the field supply is active.

8.2 Input Data

The input data is sent from the S67-DI8-M12×8 module to the field bus coupler. The process image of the S67-DI8-M12×8 module can contain process data with or without diagnostic messages. If synchronous diagnostic data is parameterized for the module, the process image size is 2 bytes. Otherwise, the process image size is 1 byte.

The byte configuration is as follow:

¹⁾ Synchronous diagnostic information specifies the cyclic diagnostic information transfer in the process image. The cyclic diagnostic information data transfer is enabled by default in the module.

Process Images

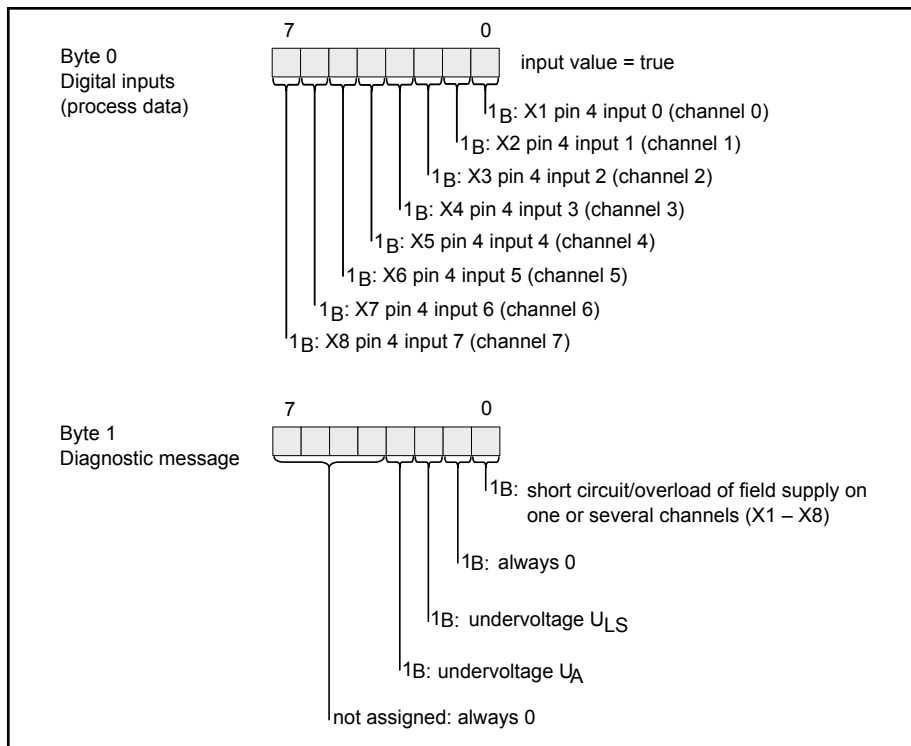

Fig. 8-1: Process image, input data

8.3 Output Data

The process image for the output data that is transmitted from the fieldbus coupler to the S67-DI8-M12×8 module has a size of 1 byte if a synchronous diagnostic confirmation has been parameterized. Otherwise, this output data is not contained in the process image.

The diagnostic confirmation is structured as follows:

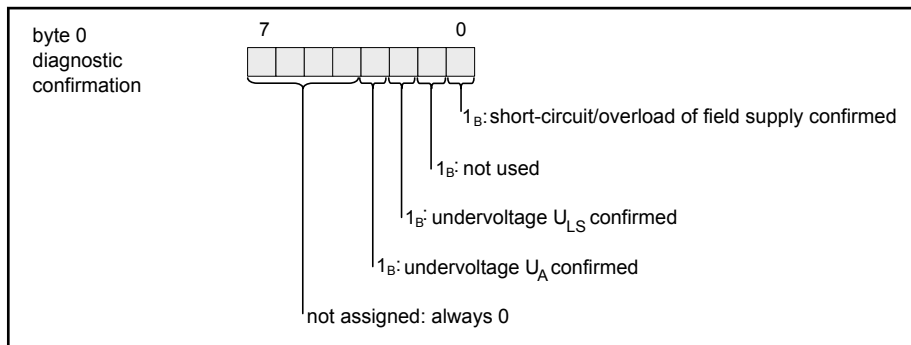

Fig. 8-2: Process image, output data

9 Parameterization

9.1 General Information

According to the field bus type, only certain parameters are available for parameterization. For further information, refer to respective field bus coupler manuals.

⚠ WARNING

Changing parameters!

When parameters are changed incorrectly, machine components can be in a dangerous state and endanger personnel and machines. Before changing the parameters, ensure that the machine components are in a safe and defined state and switch off the parent control. Ensure before commissioning that no personnel is in the danger zone of the machine components.

When parameterizing with IndraWorks, set the operating settings of the S67-DI8-M12×8 module, e.g. the response in case of error and the release of diagnostic messages.

The operating settings are transmitted via parameter telegram to the S67-DI8-M12×8 module operated at the S-BUS.

The S67-DI8-M12×8 module is parameterized in IndraWorks. Double-click on the S67-DI8-M12×8 module in the Project Explorer to open the parameterization interface in the workspace. The S67-DI8-M12×8 module is parameterized offline. The offline mode enables the parameterization of a not yet existing S67-DI8-M12×8 module. The set parameters are first saved in the project. The parameter data is applied during the PLC program download.

9.2 Diagnostic Overview

The diagnostic messages of the S67-DI8-M12×8 module are specified according to the following tables:

Global diagnostics	Description
Undervoltage U_{LS}	In case of an undervoltage of < 18 V at the module of the logic and sensor supply (U_{LS}), a corresponding diagnostic message is sent to the field bus coupler and the F-LED is lit. The parameterized substitute value strategy is applied to the digital inputs
Undervoltage U_A	In case of an undervoltage of < 18 V of the actuator supply (U_A) at the device, a corresponding diagnostic message is sent to the field bus coupler and the F-LED is lit. The undervoltage of the actuator supply does not affect the device
Short circuit/overload field supply	The module short-circuited or a field supply overload is detected (only possible if field supply active)

Tab. 9-1: Information on existing module diagnostics

9.3 Input Parameters

The following parameters are available for each channel of the S67-DI8-M12×8 module:

Parameterization

Parameter	Description
Diagnostics	Enable/disable the channel-specific diagnostics: - Lock [Ⓞ] - Unlock
Filter time	Set the input filter for the measured signals. The following options are available: - None - 0.1 ms - 0.5 ms - 3.0 ms [Ⓞ] - 15.0 ms - 20.0 ms
Substitute value response	The substitute value strategy can be specified. This strategy reports the substitute value or the last input value in case of a field bus interruption. The following substitute value strategies can be selected: - Apply substitute value [Ⓞ] - Retain last value
Substitute value	The substitute values strategy is applied to the module inputs. The following options can be selected: - 0 [Ⓞ] - 1

Ⓞ Delivery state

Tab. 9-2: Parameters available for each module channel

9.4 Automatic Storage of System Parameters

Some field bus couplers provide the "System Parameter Handling" function. This function detects configuration changes at the IndraControl S67 node and is used for the automatic module parameterization. If a module has to be replaced, the new module does not have to be parameterized. The stored parameters are automatically applied to the replaced module.

9.5 Firmware Update

During a firmware update of the S67-DI8-M12×8 module, the stored module parameters can be overwritten. Thus, check the parameterization after a firmware update.



The firmware can only be updated by the Bosch Rexroth Service.

10 Diagnostics via LED Signals

10.1 General information

For on-site diagnostics, the S67-DI8-M12×8 module has different LEDs indicating the operating states of module and S-BUS.

10.2 Operating Messages of the Module

The following table lists the operating messages indicated via LEDs. Information on remedies of certain causes is also provided.



Diagnostics can be disabled

Disable specific diagnostics (see F- and Er-LED) using the diagnostic overview (see [chapter 9.2 "Diagnostic Overview" on page 41](#)). In this case, the corresponding LED is not active (off).

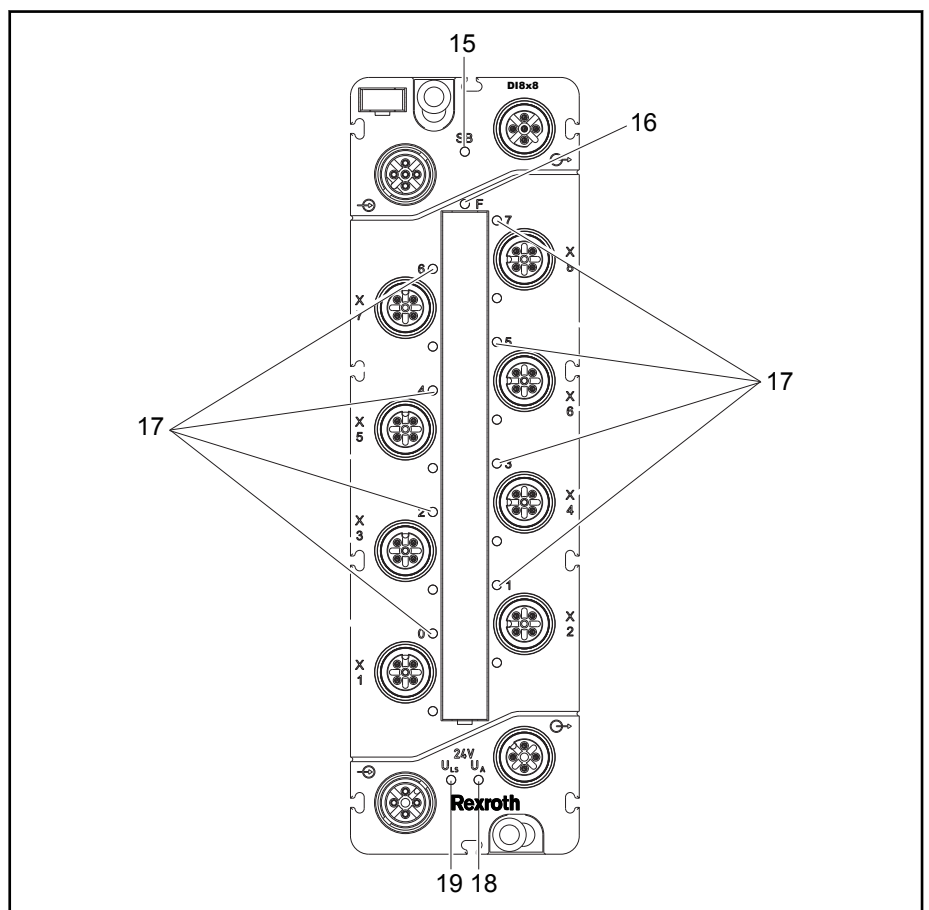

Fig. 10-1: LEDs indicating operating messages

Diagnostics via LED Signals

Position	LED	Color/status	Cause	Remedy/information
15	SB	Off	Undervoltage U_{LS} not present	Check supply voltage
		Red, flashing, 4 Hz	S-BUS error at module	Check whether the S-BUS cable is connected. Check the S-BUS cable for damages. Check whether the firmware of the field bus coupler and the module are compatible
		Red, flashing, 1 or 2 Hz	The module is reset via the field bus coupler	If the flashing frequency is 1 Hz, contact the Bosch Rexroth service
		Green	Data is exchanged. Process data values are valid. The module is in RUN state	–
		Green and orange, flashing, 1 Hz	The set substitute value is applied to the module	Can be set by the field bus coupler if field bus is missing. Check the field bus connection as well as the status of the parent control
		Orange, flashing, 2 Hz	Module detected S-BUS	–
		Orange and green, flashing, 4 Hz	Detection of last module in IndraControl S67 node is executed	Check S-BUS terminator or wiring
		Orange, flashing, 1 Hz	Field bus coupler addresses module in node	–
		Orange and green, flashing, 2 Hz	S-BUS parameters applied by field bus coupler	–
		Orange	Firmware update	All IndraControl S67 components are updated by the field bus coupler within the node
15	SB	Green, flashing 1 Hz	Module in HOLD state	Initiated by field bus coupler. Last input values transmitted to field bus coupler are retained in process image
		Green, flashing 2 Hz	The module is in STOP state	Initiated by field bus coupler. Input values are set to "0" in the process image

Tab. 10-1: Operating messages 1

Diagnostics via LED Signals

Position	LED	Color/status	Cause	Remedy/information
16	F	Red	At least one global diagnostic message occurred at module	Check supply voltages U_{LS} and U_A of upstream IndraControl S67 components and/or connected sensors
17	I/O	Yellow	Input signal present (1)	–

Tab. 10-2: Operating messages 2

Position	LED	Color/status	Cause	Remedy/information
18	U_A	Green	Actuator supply U_A present	–
		Off	Actuator supply U_A not present	Connect supply voltage and check voltage level if required
19	U_{LS}	Green	Logic and sensor supply U_{LS} present	–
		Off	Logic and sensor supply U_{LS} not present	Connect supply voltage and check voltage level if required

Tab. 10-3: Operating messages 3

11 Maintenance and Service

11.1 General Information

This section contains information on maintenance and service.

11.2 Replacing the Module

11.2.1 General Information

To replace a S67-DI8-M12×8 module in the event of version change, etc., proceed as described in the following chapters.

11.2.2 Disconnecting the Wiring

Before removing the connectors, clean the S67-DI8-M12×8 module to ensure that no dirt or other material comes in contact with the connections. This could damage the contacts.

To unplug the cables, proceed as follows:

1. Disconnect the power supply from those devices on which you have mounted the S67-DI8-M12×8 module.

⚠ CAUTION

Hot connection sockets!

Even when taking into account derating, high surface temperatures on the metallic connection sockets and on the enclosure can arise during operation. If the IndraControl S67 component has been in operation, allow the component to cool off before touching it.

2. Unscrew all screw connections and remove the cables.

11.2.3 Removing the Field Bus Coupler from the System

To remove the S67-DI8-M12×8 module from the system, proceed as follows:

1. Disconnect the power supply from those devices on which you have mounted the S67-DI8-M12×8 module.
2. Release the S67-DI8-M12×8 module from the system by unscrewing the M4 screws.

11.2.4 Removing the Field Bus Coupler from the Carrier Plate

In order to keep a clear representation, the mounting rail adapter in the figure below (B, C) is shown without the S67-DI8-M12×8 module.

If the S67-DI8-M12×8 module is mounted on a mounting rail, proceed with the removal as follows:

1. Disconnect the power supply from those devices on which you have mounted the S67-DI8-M12×8 module.
2. To remove the S67-DI8-M12×8 module, press down the release eyebolt of the mounting rail adapter using a slot screwdriver (B) and remove it from the rail (C).

Maintenance and Service

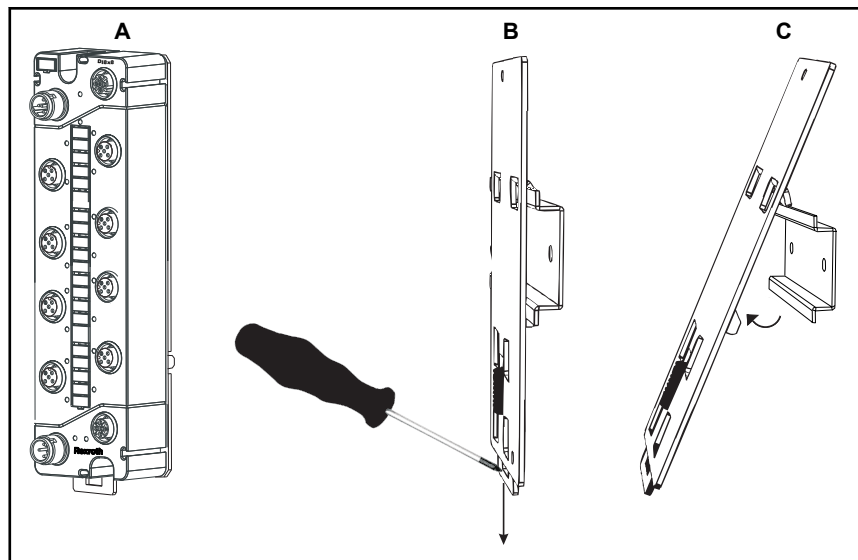

Fig. 11-1: Removing the module with mounting rail adapter from the mounting rail

11.2.5 Removing the Field Bus Coupler from the Profile Adapter

If the S67-DI8-M12×8 module is mounted on a profile adapter, proceed with the removal as follows:

1. Disconnect the power supply from the device on which you have mounted the S67-DI8-M12×8 module before starting to remove the module.
2. Unscrew the screws on which the nuts are fastened and remove the S67-DI8-M12×8 module from the profile rail of the system.
3. Unscrew the screws that connect the S67-DI8-M12×8 module to the profile adapter.

11.2.6 Connecting the Module

To connect the new S67-DI8-M12×8 module proceed as described in the following chapters:

- [chapter 5 "Mounting the Module" on page 23](#)
- [chapter 6 "Connecting Data and Supply Cables" on page 31](#)
- [chapter 7 "Commissioning" on page 37](#)

If necessary, the parameters of the previous S67-DI8-M12×8 module are transferred to the new module, depending on the type of the field bus coupler being used (see also [chapter 9.4 "Automatic Storage of System Parameters" on page 42](#)).

11.3 Disposal

Do not dispose of the IndraControl S67 components in the household waste; comply with applicable law. You can also contact a certified disposal company.

12 Accessories

12.1 General information

The most important IndraControl S67 accessory components to commission the IndraControl S67-DI8-M12×8 module are listed.

12.2 Assembled S-BUS Cables

Cable carrier compatibility:

- RKB0041: No cable carrier compatibility specified
- RKB0049: Cable carrier-compatible

Bending radii and bending cycles:

RKB0041:

- Smallest bending radius, fix installation: At least 5 x cable diameter
- Number of bending cycles: 3 millions

RKB0049:

- Smallest bending radius, fix installation: At least 5 x cable diameter
- Smallest bending radius, flexible use: At least 5 x cable diameter
- Number of bending cycles: 3 millions

Tensile load:

- Cable, tensile load: 60 N
- Connector, tensile load: 60 N

Temperature ranges:

RKB0041:

- Continuous operation temperature, idle state: -20 °C ... +60 °C
- Storage/transport: 0 °C ... +50 °C
- Mounting: 0 °C ... +50 °C

RKB0049:

- Continuous operation temperature, idle state: -30 °C ... +85 °C
- Continuous operation temperature, moving state: 0 °C ... +50 °C
- Storage/transport: 0 °C ... +50 °C
- Mounting: 0 °C ... +50 °C



For the connector assignment of the S-BUS connection as well as the notes on the S-BUS cable connection, refer to the chapter "Connecting Data and Supply Cables".

System bus cable, M12 axial socket, M12 axial socket

Ordering code	Parts number	Length
RKB0049/000,2	R911347534	0.2 m
RKB0049/000,5	R911347535	0.5 m
RKB0049/001,0	R911347474	1.0 m
RKB0049/002,0	R911347537	2.0 m
RKB0049/003,0	R911347475	3.0 m

Accessories

Ordering code	Parts number	Length
RKB0049/004,0	R911347538	4.0 m
RKB0049/004,5	R911347539	4.5 m
RKB0049/005,0	R911347476	5.0 m
RKB0049/005,5	R911347540	5.5 m
RKB0049/006,0	R911347541	6.0 m
RKB0049/006,5	R911347542	6.5 m
RKB0049/007,0	R911347543	7.0 m
RKB0049/007,5	R911347477	7.5 m
RKB0049/010,0	R911347478	10.0 m
RKB0049/010,5	R911347544	10.5 m
RKB0049/012,0	R911347545	12.0 m
RKB0049/014,0	R911347546	14.0 m
RKB0049/015,0	R911347479	15.0 m
RKB0049/016,5	R911347547	16.5 m
RKB0049/017,0	R911347548	17.0 m
RKB0049/018,0	R911347549	18.0 m
RKB0049/019,0	R911347550	19.0 m
RKB0049/020,0	R911347480	20.0 m
RKB0049/020,5	R911347551	20.5 m
RKB0049/021,0	R911347552	21.0 m
RKB0049/023,0	R911347553	23.0 m
RKB0049/025,0	R911347481	25.0 m
RKB0046/000,0	R911172581	Variable length

Tab. 12-1: S-BUS cable, ready-made on both sides

Ordering code	Parts number	Length
RKB0041/000,2	R911171990	0.2 m
RKB0041/000,3	R911171991	0.3 m
RKB0041/000,5	R911171992	0.5 m
RKB0041/001,0	R911171993	1.0 m
RKB0041/002,0	R911171994	2.0 m
RKB0041/005,0	R911171995	5.0 m
RKB0041/010,0	R911171996	10.0 m
RKB0041/000,0	R911172579	Variable length

Tab. 12-2: S-BUS cable, ready-made on both sides

S-BUS terminator, axial plug

Ordering code	Parts number
RBS0020/CNN	R911171998

Tab. 12-3: S-BUS terminator

12.3 Ready-Made Supply Cables

Cable carrier compatibility:

- RKB0046: Cable carrier-compatible
- RKB0047: Cable carrier-compatible

Bending radii and bending cycles:

RKB0046:

- Smallest bending radius, flexible use: At least 10 x cable diameter
- Number of bending cycles: 5 millions

RKB0047:

- Smallest bending radius, flexible use: At least 10 x cable diameter
- Number of bending cycles: 3 millions

Tensile load:

- Cable, tensile load: 45 N
- Connector, tensile load: 45 N

Temperature ranges:

RKB0046:

- Continuous operation temperature, idle state: -30 °C ... +80 °C
- Continuous operation temperature, moving state: -30 °C ... +80 °C
- Storage/transport: -5 °C ... +80 °C
- Mounting: -5 °C ... +80 °C

RKB0047:

- Continuous operation temperature, idle state: -30 °C ... +80 °C
- Continuous operation temperature, moving state: -30 °C ... +80 °C
- Storage/transport: -30 °C ... +80 °C
- Mounting: -30 °C ... +80 °C



The pin assignment of the supply connection is described in the chapter "Connecting Data and Supply Cables".

Voltage cable, unshielded, 4-pin, 0.75 mm², PUR M12 connector, straight, A-coded - M12 female connector, straight, A-coded

Ordering code	Parts number	Length
RKB0046/000,2	R911172102	0.2 m
RKB0046/000,3	R911172103	0.3 m
RKB0046/000,5	R911172104	0.5 m
RKB0046/001,0	R911172105	1.0 m
RKB0046/002,0	R911172106	2.0 m

Accessories

Ordering code	Parts number	Length
RKB0046/005,0	R911172107	5.0 m
RKB0046/010,0	R911172108	10.0 m
RKB0046/000,0	R911172580	Variable length

Tab. 12-4: Supply cable, A-coded - Male and female connector

Voltage cable, unshielded, 4-pin, 0.75 mm², PUR M12 female connector, straight, A-coded - Open end

Ordering code	Parts number	Length
RKB0047/005,0	R911172100	5.0 m
RKB0047/010,0	R911172101	10.0 m

Tab. 12-5: Supply cable, A-coded - Female connector, open end

12.4 Carrier Rail Adapter, Profile Adapter and Spacer

Ordering code	Parts number	Brief description
SUP-M01-S67-0010	R911173303	Carrier rail adapter for 8×M12 I/O modules
SUP-M01-S67-0011	R911173304	Profile adapter for 8×M12 I/O modules
SUP-M01-S67-0001	R911172119	Carrier rail adapter for field bus coupler
SUP-M01-S67-0002	R911172120	Carrier rail adapter for short I/O modules and power distributors
SUP-M01-S67-0003	R911172121	Profile adapter for field bus coupler
SUP-M01-S67-0004	R911172122	Profile adapter for short I/O modules and power distributors
SUP-M01-S67-0005	R911172123	Spacer

Tab. 12-6: Carrier rail adapter, profile adapter and spacer

12.5 End Clamp

Ordering code	Parts number	Brief description
SUP-M01-ENDHALTER	R911170685	Rapid assembly end clamp for 35 mm NS 35/7,5 or NS 35/15 carrier rail, width: 9.5 mm
SUP-M01-ENDHALTER/AL	R911171035	End clamp for 35 mm NS 35/7,5 or NS 35/15 carrier rail, model: Aluminum, 2 screws used for fixing, width: 10 mm
SUP-M01-ENDHALTER/PA	R911172352	End clamp for 35 mm carrier rail, model: Polyamide, width: 9.5 mm

Tab. 12-7: End clamp

12.6 Protective caps

Protective caps for female and male connectors that are not assigned (M8, M12)

Ordering code	Parts number	Brief description
RF-PROT-M8	R911170895	Protective cap M8 (external thread)
RF-PROT-M12-M	R911171999	Protective cap M12 (internal thread)
SUP-M01-SM*12.1	R911277260	Protective cap M12 (external thread)

Tab. 12-8: Protective caps

12.7 Module Labeling Strips

Ordering code	Parts number	Brief description
SUP-M01-S67-0009	R911173271	Labeling strip 8×M12 (for 8×M12 I/O modules) VPE=10

Tab. 12-9: Module labeling strips

13 Appendix

13.1 Diagnostic Information

Some field bus couplers display the error code in the form of an attribute path (CIA), through which the diagnostics can be clearly assigned. Other field bus couplers (e.g. Profinet I/O or Profibus DP) convert the attribute path into the respecting field bus-specific message.

The following diagnostic codes can be generated by the S67-DI8-M12×8 module:

Diagnostic message	Attribute path			Classification
	C	I	A	
Short circuit of field supply This function is only active when the field supply is switched on	16	1	128	Diagnostic alarm
Undervoltage U_{LS} (Sensor supply)	50	1	128	Diagnostic alarm
Undervoltage U_A (Actuator supply)	50	1	129	Diagnostic alarm

Tab. 13-1: Diagnostics of the module

14 Service and support

Our worldwide service network provides an optimized and efficient support. Our experts offer you advice and assistance should you have any queries. You can contact us **24/7**.

Service Germany Our technology-oriented Competence Center in Lohr, Germany, is responsible for all your service-related queries for electric drive and controls.

Contact the **Service Hotline** and **Service Helpdesk** under:

Phone: **+49 9352 40 5060**
Fax: **+49 9352 18 4941**
E-mail: service.svc@boschrexroth.de
Internet: <http://www.boschrexroth.com/>

Additional information on service, repair (e.g. delivery addresses) and training can be found on our internet sites.

Service worldwide Outside Germany, please contact your local service office first. For hotline numbers, refer to the sales office addresses on the internet.

Preparing information To be able to help you more quickly and efficiently, please have the following information ready:

- Detailed description of malfunction and circumstances
- Type plate specifications of the affected products, in particular type codes and serial numbers
- Your contact data (phone and fax number as well as your e-mail address)

Index

A

Abbreviations.....	8
About this documentation	
Validity of the documentation.....	6
Accessories.....	49
Assembled S-BUS cables.....	49
Carrier rail adapter, profile adapter and spacer.....	52
End clamp.....	53
Module labeling strips.....	53
Protective caps.....	53
Ready-made supply cables.....	51
ANSI Z535.6-2006.....	11
Appendix.....	55

C

Commissioning.....	37
Complaints.....	8
Connect data and supply cables.....	31
Connect S-BUS.....	32
Connect sensor cables.....	35
Connect supply cables.....	33
Notes.....	31
Required accessories.....	32
Connecting the module.....	48
Criticism.....	8
Customer Feedback.....	8

D

Device description.....	13
Connections.....	13
Dimensions.....	19
Display elements.....	15
Labeling and symbols at rear side.....	16
Labeling options and mounting.....	14
Schematic diagram.....	17
Technical data.....	19
Type plate.....	17
Diagnostic information.....	55
Diagnostics via LED signals.....	43
Operating messages of the module.....	43
Display elements.....	15
Displays.....	21
Disposal.....	48

F

Feedback.....	8
---------------	---

H

Hazard warnings.....	11
Helpdesk.....	57
Hotline.....	57

I

Intended use	
Application cases.....	9
Introduction.....	9
Use cases.....	9

M

Maintenance and service.....	47
Connecting the module.....	48
Field bus coupler replacement, disconnecting the wiring.....	47
Replacing the field bus coupler, removing the field bus coupler from the carrier plate.....	47
Replacing the field bus coupler, removing the field bus coupler from the profile adapter.....	48
Replacing the module.....	47
Maintenance and Service	
Replacing the field bus coupler, removing the field bus coupler from the system.....	47
Manufacturing date.....	17
Mounting of the module	
Direct mounting to the system.....	24
Mounting the field bus coupler	
Replacing the labeling fields.....	27
Required tools and accessories for mounting.....	23
Mounting the module.....	23
Mount on a mounting rail, fastening the module with mounting rail adapter to a mounting rail.....	25
Mount on carrier rail.....	24
Mount on carrier rail, fasten carrier rail adapter at the module.....	24
Mount on profile rail.....	26
Mount on profile rail, fasten the module with profile adapter on profile rail.....	27
Mount on profile rail, fasten the profile rail at the module.....	26
Mounting notes.....	23
Mounting the spacer in case of compact arrangement.....	28

P

Parameterization.....	41
Automatic storage of system parameters.....	42
Diagnostic overview.....	41
Firmware update.....	42
Input parameters.....	41
Parts number.....	17
Process images.....	39
Input data.....	39
Output data.....	40
Product phases.....	6

S

Safety alert symbol.....	11
--------------------------	----

Index

Safety instructions.....	11
Schematic diagram.....	17
Scope.....	5
Serial number.....	17
Service hotline.....	57
Signal words.....	11
Structure documentation.....	7
Suggestions.....	8
Support.....	57
Symbols.....	12

T

Target groups.....	6
Technical data	
Communication.....	20
Diagnostics I/O.....	21
Digital inputs.....	20
Displays.....	21
Electrical isolation.....	21
Input characteristic curve.....	21
Module supply.....	20
Parameterizable functions.....	21
Process image.....	21
Standards and approvals.....	22
Technical data.....	19
Technical index.....	17
Terms.....	8
Terms and abbreviations.....	8
Type code	17
Type plate.....	17

U

Unintended use.....	10
Consequences, exclusion of liability.....	9

W

Warnings.....	11
---------------	----

Notes

Bosch Rexroth AG

Electric Drives and Controls

P.O. Box 13 57

97803 Lohr, Germany

Bgm.-Dr.-Nebel-Str. 2

97816 Lohr, Germany

Tel. +49 9352 18 0

Fax +49 9352 18 8400

www.boschrexroth.com/electrics



R911342194