

# Rexroth IndraControl

VDP 15.3, 21.3 Multi Touch  
Operating Display – Housing Device

**Operating Instructions**  
**R911342319**

Edition 01



## Change Record

Edition	Release Date	Notes
Edition 01	2014-09	First edition

## Copyright

© Bosch Rexroth AG 2014

This document, as well as the data, specifications and other information set forth in it, are the exclusive property of Bosch Rexroth AG. It may not be reproduced or given to third parties without its consent.

## Liability

The specified data is intended for product description purposes only and shall not be deemed to be a guaranteed characteristic unless expressly stipulated in the contract. All rights are reserved with respect to the content of this documentation and the availability of the product.

## Editorial Department

Development automation systems control platform HB (MK/MePe)

# Table of Contents

	Page
<b>1</b>	<b>About this documentation..... 1</b>
<b>2</b>	<b>Product identification and scope of delivery..... 2</b>
2.1	Product Identification..... 2
2.2	Scope of delivery..... 3
<b>3</b>	<b>Using safety instructions..... 3</b>
3.1	Safety instructions – Structure..... 3
3.2	Explaining signal words and safety alert symbol..... 4
3.3	Symbols Used..... 4
<b>4</b>	<b>Intended use..... 5</b>
<b>5</b>	<b>Spare parts, accessories and wear parts..... 5</b>
5.1	Y-repeater..... 5
5.2	External 24 V power supply unit ..... 6
5.3	Uninterruptible power supply (UPS)..... 6
5.4	Connecting cables for CDI interface..... 6
5.5	Rubber grommet for cable bushing..... 7
5.6	Wear parts..... 7
<b>6</b>	<b>Ambient conditions..... 7</b>
<b>7</b>	<b>Technical data..... 8</b>
7.1	General technical data..... 8
7.2	E-STOP button..... 9
7.3	Optical characteristic values..... 9
7.3.1	TFT..... 9
7.3.2	Input system (multi-touch front)..... 9
<b>8</b>	<b>Standards..... 9</b>
8.1	General information..... 9
8.2	Standards used..... 9
8.3	CE marking..... 10
8.3.1	Declaration of conformity..... 10
8.4	UL/CSA Certified..... 11

	Page
<b>9 Interfaces</b> .....	<b>11</b>
9.1 Display.....	11
9.1.1 View.....	11
9.1.2 Overview.....	12
9.1.3 24 V DC voltage supply.....	12
9.1.4 S1 DIP switch.....	13
9.1.5 USB interfaces.....	13
9.1.6 XSER and XVID interfaces.....	14
9.2 Keypad.....	14
9.2.1 View.....	14
9.2.2 Overview.....	15
9.2.3 Keypad connection scheme.....	15
9.2.4 Pin assignment of the keypad.....	16
<b>10 Mounting, demounting and electric installation</b> .....	<b>17</b>
10.1 Housing dimensions.....	17
10.1.1 Rexroth design.....	17
10.2 Installation notes.....	18
10.3 Mounting.....	19
10.4 Demounting.....	22
10.5 Electrical wiring.....	22
10.5.1 Connecting operating display to control cabinet.....	22
10.5.2 Connecting operating display to 24 V voltage supply.....	24
10.5.3 Connection diagram.....	25
10.5.4 Recommendation for the assembly of CDI cables with long lengths in an interference-prone environment.....	25
<b>11 Commissioning</b> .....	<b>28</b>
<b>12 Device description</b> .....	<b>28</b>
12.1 General information.....	28
12.2 Operating and error displays.....	29
<b>13 Error causes and troubleshooting</b> .....	<b>30</b>
<b>14 Maintenance</b> .....	<b>31</b>
14.1 General information.....	31
14.2 Display.....	31

	Page
14.3	Cleaning notes..... 31
14.4	Regular maintenance tasks..... 31
<b>15</b>	<b>Ordering information..... 31</b>
15.1	Accessories and spare parts..... 31
15.2	Type code..... 32
<b>16</b>	<b>Disposal..... 34</b>
16.1	Return..... 34
16.2	Packaging..... 34
<b>17</b>	<b>Service and support..... 34</b>
	<b>Index..... 37</b>



# 1 About this documentation

## Overview on target groups and product phases

The activities, product phases and target groups that refer to the present documentation are highlighted in red color in the following figure.

Example: In the product phase "Mounting (assembly/installation)", the "mechanic/electrician" can execute the activity "install" using this documentation.

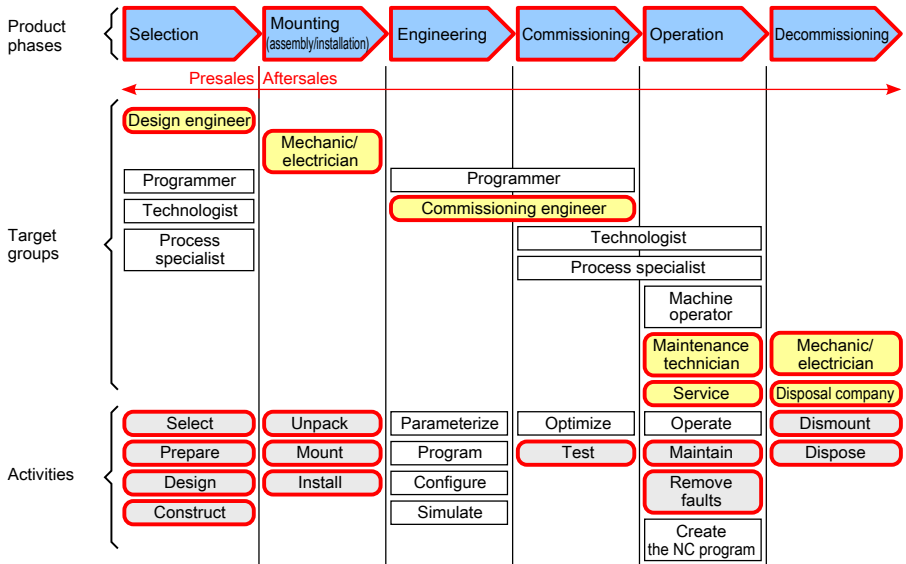

Fig. 1-1: Assigning the present documentation to the target groups, product phases and activities of the target group

### Purpose

This document instructs the technical staff of the machine manufacturer on how to perform the mechanical and electrical installation safely and on how to commission the device.

Required qualifications: Individual who is able to assess the tasks assigned and identify possible safety risks owing to qualification in the subject, knowledge and experience. The individual should also be familiar with the standards and regulations.

### Scope

This operating instructions applies to all multi-touch operating displays listed in the type code, refer to [chapter 15.2 "Type code" on page 32](#).

The type code specifications are located on the type plate of the device. Also refer to [chapter 2.1 "Product Identification" on page 2](#).

## Related documents

Title	Parts number and document type
Rexroth IndraControl VAP 01 Power Supply Unit	<a href="#">R911339613</a> Operating Instructions
Rexroth IndraControl VAU 01.1 UPS with Communication Interface	<a href="#">R911336867</a> Operating Instructions
Rexroth IndraControl VAC 01 Y-repeater	<a href="#">R911336973</a> Operating Instructions
Rexroth IndraControl V Devices Operating Systems	<a href="#">R911343901</a> Project Planning Manual

**Tab. 1-1:** Related documentation

## Customer feedback

Customer requests, comments or suggestions for improvement are of great importance to us. Please email your feedback on the documentations to [Feedback.Documentation@boschrexroth.de](mailto:Feedback.Documentation@boschrexroth.de). Directly insert comments in the electronic PDF document and send the PDF file to Bosch Rexroth.

## 2 Product identification and scope of delivery

### 2.1 Product Identification

The type plate is located on the rear side or at the side of the device.

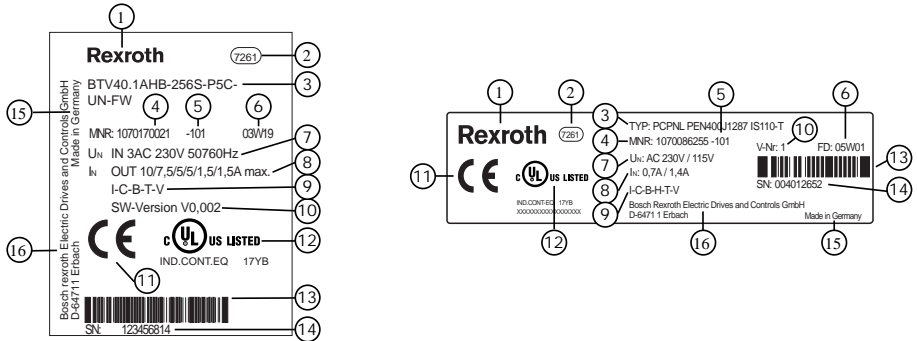

- 1 Logotype
- 2 Division or plant number
- 3 Type designation code (type code)
- 4 Parts number
- 5 State of revision
- 6 Date of manufacture (yyWww)
- 7 Nominal voltage
- 8 Nominal current

- 9 Test marking
- 10 Version number
- 11 CE mark
- 12 Underwriters Laboratories Inc. mark
- 13 Serial number as barcode
- 14 Serial number
- 15 Designation of origin
- 16 Company address

Fig. 2-1: Exemplary type plates

## 2.2 Scope of delivery

- Operator display
- Safety instructions
- Sealing insert cable PCT

## 3 Using safety instructions

### 3.1 Safety instructions – Structure

The safety instructions are structured as follows:

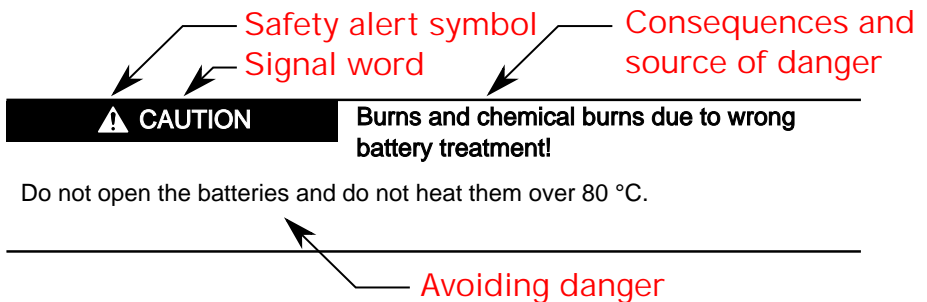

Fig. 3-1: Safety instructions – structure

## 3.2 Explaining signal words and safety alert symbol

The safety instructions in this documentation contain specific signal words (danger, warning, caution, notice) and, if necessary, a safety alert symbol (according to ANSI Z535.6-2006).

The signal word is used to draw attention to the safety instruction and also provides information on the severity of the hazard.

The safety alert symbol (a triangle with an exclamation point), which precedes the signal words danger, warning and caution is used to alert the reader to personal injury hazards.

---

### **DANGER**

In the event of non-compliance with this safety instruction, death or serious injury **will** occur.

---

---

### **WARNING**

In the event of non-compliance with this safety instruction, death or serious injury **will** occur.

---

---

### **CAUTION**

In the event of non-compliance with this safety instruction, minor or moderate injury can occur.

---

---

### **NOTICE**

In the event of non-compliance with this safety instruction, material damage can occur.

---

## 3.3 Symbols Used

Pointers are displayed as follows:



This is a note.

---

Tips are displayed as follows:



This is a tip.

---

## 4 Intended use

The Bosch Rexroth operator terminals are passive operator and visualization terminals. They form a PC-based operator terminal when used with a Bosch Rexroth control cabinet PC.

---

**NOTICE**

**Danger of device damage if not the expressly stated accessories, mounting parts, components, cables, lines, software and firmware are used.**

The operator displays may be used only as intended and with the accessories, mounting parts and other components specified in this documentation. Components that are not expressly mentioned must neither be attached nor connected. The same applies to cables and lines.

Only to be operated with the component configurations and combinations expressly defined and with the software and firmware specified in the corresponding functional description.

---

Typical areas of application of the operating display:

- Handling systems and assembly systems
- Packaging and food processing machines
- Printing machines and paper converting machines
- Machine tools
- Wood processing machines

The operator displays may only be operated under the mounting and installation conditions, the position and the ambient conditions (temperature, degree of protection, humidity, EMC etc.) specified in this documentation.

---

**NOTICE**

**Risk of destroying the touch screen or the front panel by using inappropriate items.**

Operate the touch screen only with your finger or with a special touch pen (parts number 1070923266).

---

## 5 Spare parts, accessories and wear parts

### 5.1 Y-repeater

Connecting unit to connect two operating displays with the same resolution and version to one control cabinet PC.

Ordering code	Parts number	Description
VAC01.1S-YD1-TCES	R911172852	Y-repeater for CDI interface

Tab. 5-1: Y-repeater

## 5.2 External 24 V power supply unit

Ordering code	Parts number	Description
VAP01.1H-W23-024-010-NN	R911171065	External 24 V power supply unit for IndraControl V devices

Tab. 5-2: External 24 V power supply unit for the operating display

## 5.3 Uninterruptible power supply (UPS)

Ordering code	Parts number	Description
VAU01.1U-024-024-240-NN	R911171024	Uninterruptible power supply DC 24 V, 240 watts with USB interface

Tab. 5-3: Uninterruptible power supply (UPS)

## 5.4 Connecting cables for CDI interface



**Malfunctions caused by using inappropriate CDI cables.**

Use only cables listed in the following.

Ordering code	Parts number	Description
RKB0008/000,5 (*****-*****-*****)	R911171484	Length: 0.5 m
RKB0008/001,0 (*****-*****-*****)	R911171485	Length: 1 m
RKB0008/002,5 (*****-*****-*****)	R911170151	Length: 2.5 m
RKB0008/005,0 (*****-*****-*****)	R911170152	Length: 5 m
RKB0008/007,5 (*****-*****-*****)	R911172971	Length: 7.5 m
RKB0008/010,0 (*****-*****-*****)	R911170153	Length: 10 m
RKB0008/015,0 (*****-*****-*****)	R911171183	Length: 15 m
RKB0008/020,0 (*****-*****-*****)	R911171184	Length: 20 m
RKB0008/025,0 (*****-*****-*****)	R911170154	Length: 25 m
RKB0008/030,0 (*****-*****-*****)	R911171381	Length: 30 m
RKB0008/035,0 (*****-*****-*****)	R911171369	Length: 35 m
RKB0008/040,0 (*****-*****-*****)	R911171382	Length: 40 m
RKB0008/050,0 (*****-*****-*****)	R911171383	Length: 50 m

Tab. 5-4: Connecting cables to control cabinet PC, panel PC and operating display  
Further cable lengths are available on request.



Two cables are always required to establish a connection between the VxB and the VDP.

## 5.5 Rubber grommet for cable bushing

Ordering code	Parts number	Description
DICHTEINSATZ KABEL PCT	1070093579	Rubber grommet for cable bushing

Tab. 5-5: Rubber grommet

## 5.6 Wear parts

Wear parts are not subject to any warranty.

### Backlight

The service life of the backlight is limited. After this period, the backlight will produce only 50 % of its original brightness. The service life is approx. 50,000 hours at an ambient temperature of 25 °C.

## 6 Ambient conditions

	In operation	Transport	Storage
Max. ambient temperature	+0 °C to +45 °C	-20 °C to +60 °C	-20 °C to +60 °C
Max. temperature gradient	Temporal temperature changes up to 3 K per minute	Temporal temperature changes up to 3 K per minute	Temporal temperature changes up to 3 K per minute
Humidity	Min. relative humidity: 5 %	Min. relative humidity: 5 %	Min. relative humidity: 5 %
	Max. relative humidity: 85 %	Max. relative humidity: 75 %	Max. relative humidity: 85 %
	Min. absolute humidity: 1 g/m <sup>3</sup>	Min. absolute humidity: 1 g/m <sup>3</sup>	Min. absolute humidity: 1 g/m <sup>3</sup>
	Max. absolute humidity: 25 g/m <sup>3</sup>	Max. absolute humidity: 25 g/m <sup>3</sup>	Max. absolute humidity: 25 g/m <sup>3</sup>
	Condensation not allowed	Condensation not allowed	Condensation not allowed
	Corresponds to climatic class 3K3 acc. to EN 60721-3-3	Corresponds to climatic class 2K2 acc. to EN 60721-3-2	Corresponds to climatic class 1K2 acc. to EN 60721-3-1
Air pressure	Up to 3000 m above sea level acc. to EN 61131-2	Up to 3000 m above sea level acc. to EN 61131-2	Up to 3000 m above sea level acc. to EN 61131-2

	In operation	Transport	Storage
Mechanical strength	Max. vibration: Frequency range: 10 ... 150 Hz Excursion: 0.075 mm at 10 Hz to 57 Hz Acceleration: 1 g at 57 Hz to 150 Hz Acc. to EN 600068-2-6	Max. shock: 15 g 11 ms Acc. to EN 60068-2-27, No disturbance of the func- tion	Max. shock: 15 g 11 ms Acc. to EN 60068-2-27, No disturbance of the func- tion
Contamination level	2	2	2
Overvoltage category	2	-	-

Tab. 6-1: Ambient conditions



The ambient air must not contain acids, alkaline solutions, corrosive agents, salts, metal vapors and other electrically conductive contaminants in high concentrations.

## 7 Technical data

### 7.1 General technical data

	VDP 15.3GA (Rexroth design)	VDP 21.3GC (Rexroth design)
Display	396 mm TFT (15") 1366 × 768 pixels 16.7 million colors	546 mm TFT (21") 1920 × 1080 pixels 16.7 million colors
Operation	Multi touch	
Surface of the front panel	Thermally tempered glass	
Degree of protection	Front panel IP 65 acc. to DIN EN 60 529 Front type 1 acc. to NEMA (UL)	
Voltage supply	DC 24 V (use a 24 V power supply unit acc. to DIN EN 60742, classification VDE 0551, for example the VAP01.1H-W23-024-010-NN, parts number R911171065)	
Current consumption	Approx. 1 A	Approx. 1.5 A
Power loss	Approx. 24 W	Approx. 36 W
USB	Per USB port max. 500 mA, total current at all USB ports max. 1 A.	
Weight	Approx. 4.8 kg	Approx. 7.4 kg

Tab. 7-1: Technical data of the VDP 15.3 and VDP 21.3

## 7.2 E-STOP button

Mechanics	Electrics
B10d = 250,000	B10d = 5,000,000
Exclusion of failure at <6,050 switching cycles	Exclusion of failure at <6,050 switching cycles

**Tab. 7-2:** Service life characteristic value of the E-STOP button

## 7.3 Optical characteristic values

### 7.3.1 TFT

The maximum permissible number and type of pixel errors of TFT displays depends on the manufacturer and is defined by the the respective "incoming inspection" of the manufacturer. This "incoming inspection" is provided by the Bosch Rexroth service if required.

### 7.3.2 Input system (multi-touch front)

The maximum permissible number and type of defects on the front or the glass, such as trapped dust, scratches, etc. is defined in the FT<sup>1)</sup>. The VDP multi-touch devices meet the quality guideline.

## 8 Standards

### 8.1 General information

The products have been developed according to the current German edition of the standards at the time of product development.

### 8.2 Standards used

Standard	Meaning
EN 60,204-1	Safety of machinery - Electrical equipment of machines
EN 61,000-6-4	Generic standards - Emission standard (industrial environments)
EN 61 000-6-2	Generic standards – Noise immunity (industrial environments)
EN 61 558-2-6	Transformer for 24 V power supply unit, protective separation
EN 60,664-1	Overvoltage category II
EN 61 131-2	24 V output requirements
EN 61 131-2	24 V current supply requirements
EN 60 529	Degrees of protection (including housings and installation compartments)

1) quality standard (version December 2013) of the Fachgemeinschaft Eingabesysteme (German association for input systems).

Standard	Meaning
EN 60,068-2-6	Vibration test
EN 60,068-2-27	Shock test
EN 60 721-3-1 and EN 60 721-3-3	Climatic class

#### E-STOP button

The E-STOP button is disclosed by the manufacturer as safety component according to machinery directive 2006/42/EC (annex V-10, emergency stop devices). The compliance with the directive is proven by adherence to the following European standards:

IEC 60204-1	Safety of machinery – Electrical equipment of machines
IEC 60947-5-1/5	Requirements on positively breaking control switches and E-STOP devices
ISO 13850	Safety of machinery - Emergency stop - Principles for design

**Tab. 8-1:** Standards used

## 8.3 CE marking

### 8.3.1 Declaration of conformity



The electronic products described in the present operating instruction comply with the requirements and the target of the following EU directive and with the following harmonized European standards:

EMC Directive 2004/108/EC

The electronic products described in the present operating instruction are intended for use in industrial environments and comply with the following requirements:

Standard	Title	Edition
DIN EN 61000-6-4 (VDE 0839-6-4)	Electromagnetic Compatibility (EMC) Part: 6-4: Generic standards – Emission standard for industrial environments (IEC 61000-6-4:2006)	September 2007
DIN EN 61000-6-2 (VDE 0839-6-2)	Electromagnetic Compatibility (EMC) Part: 6-2: Generic standards – Noise immunity for industrial environments (IEC 61000-6-2:2005)	March 2006

**Tab. 8-2:** Standards for electromagnetic compatibility (EMC)



**Non-compliance with CE conformity due to modifications at the device.**

The CE marking is only valid for the device in its delivery state. After modifying the device, verify CE conformity.

## 8.4 UL/CSA Certified



The devices are certified according to

- **UL508** (Industrial Control Equipment) and
- **C22.2 No. 142-M1987** (CSA)

UL file no. E210730

However, there can be combinations or extension stages with limited or missing certification. Thus, verify the registration according to the UL marking on the device.



**Loss of UL/CSA conformity due to modifications at the device.**

UL and CSA marking applies only to the device in its delivery state. After modifying the device, UL conformity and CSA conformity are to be verified.

## 9 Interfaces

### 9.1 Display

#### 9.1.1 View

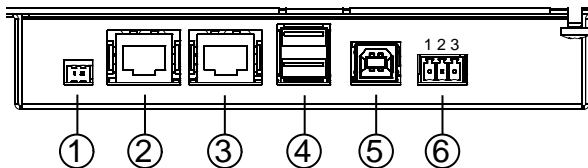

**Fig. 9-1:** Interfaces on the operating display

## 9.1.2 Overview

Name at housing	Connection type	Connector type, integrated	Mating connector or cable (from outside)
S1	See <a href="#">chapter 9.1.4 "S1 DIP switch" on page 13</a>		
XVID	CDI interface, screen	RJ45 socket	RJ45 plug
XSER	CDI interface, data	RJ45 socket	RJ45 plug
XUSB1/2	2 USB interfaces	USB socket, 4-pin, type A	USB plug, 4-pin, type A
XUSBIN	USB2.0 connection to the control cabinet PC. Maximum length 5 m Use only a high-speed USB2.0 cable (see <a href="#">chapter 5 "Spare parts, accessories and wear parts" on page 5</a> )	USB socket, 4-pin, type B	USB plug, 4-pin, type B
X1S1	24 V DC voltage supply	3-pin, MC1,5/3-G-3,5 THT	3-pin, FK-MCP 1,5/3-ST-3,5

Tab. 9-1: Interfaces

### **NOTICE**

### Malfunctions due to insufficient shielding!

Use only shielded cables and metallic or conductive connector/coupling covers with large-area shield support.

## 9.1.3 24 V DC voltage supply

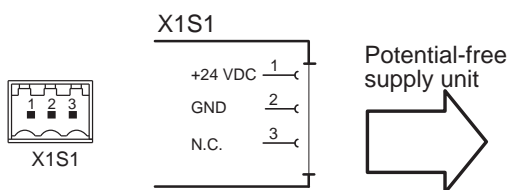

Fig. 9-2: Interface for 24 V voltage supply

Pin	Function
1	+24 V supply voltage
2	0 V supply voltage
3	n.c.

Tab. 9-2: Pin assignment X1S1

Use a 24 V industrial power supply unit acc. to DIN EN 60742, classification VDE 0551, for example "VAP01.1H-W23-024-010-NN" (parts number R911171065) for the voltage supply.

### 9.1.4 S1 DIP switch

#### Overview

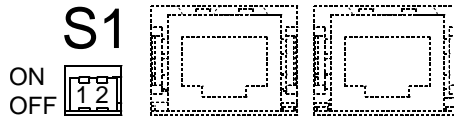

Fig. 9-3: S1 DIP switch at the connector panel of the operating display

Name at housing	Switch type	Function
S1/1	DIP switch	No function
S1/2	DIP switch	OFF: Cable length to control cabinet PC ≤ 30 m ON: Cable length to control cabinet PC > 30 m

Tab. 9-3: DIP switch at the VDP

### 9.1.5 USB interfaces

There are two USB interfaces on the connector panel (XUSB1/2) at the devices and, depending on the version, one interface on the front panel.

#### Operating USB ports at operating display

The USB speed at the operating display depends on the cable length of the XSER connection and the DIP switch setting, see [tab. 9-4 "USB speed depends on XSER cable length" on page 13](#):

Cable length of the XSER connection	DIP switch 2	USB speed	Note
Up to 5 meters	OFF	12 Mb/s	-
Up to 5 meters	OFF	480 Mb/s (USB2.0)	An additional USB cable between control cabinet PC and XUSBIN is required
From 5 to 30 meters	OFF	12 Mb/s	The connected device may not contain a USB hub
More than 30 meters	ON	12 Mb/s	Only mice and keyboards can be connected. The connected device may not contain a USB hub

Tab. 9-4: USB speed depends on XSER cable length



Interference-free USB2.0 connection only up to a cable length of 5 meters.



Connect only USB devices that meet the USB2.0 specification.



The cables of the connected USB devices have to comply with the USB2.0 specifications.



If the total current of all USB ports exceeds 1 A, the power supply unit switches off the operating display.

## 9.1.6 XSER and XVID interfaces

### CDI interface

The CDI interface is assigned to the two RJ45 sockets XSER and XVID. The connection between the control cabinet PC and the operating display is established at these sockets via two ready-made cables available as accessory, see [chapter 5 "Spare parts, accessories and wear parts" on page 5](#).

The CDI interface includes the data interface (XSER) as well as the screen interface (XVID).

### XVID and XSER marking

The CDI interfaces are color-coded on the device:

CDI interface, data (XSER)	Violet
CDI interface, screen (XVID)	Black

Tab. 9-5: Color-coding of the interface

## 9.2 Keypad

### 9.2.1 View

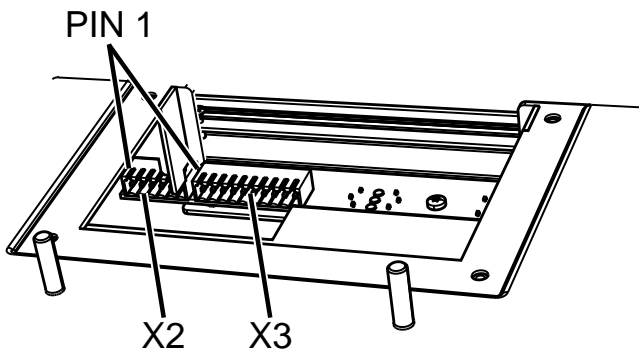

Fig. 9-4: Interfaces X2 and X3 of the keypad

**⚠ WARNING****Death or lethal injury due to incorrect handling of the E-STOP button**

- The EMERGENCY STOP pushbutton can be used as operating element in an EMERGENCY STOP circuit
- The EMERGENCY STOP circuit has to be designed by the machine manufacturer
- Only qualified persons may connect the EMERGENCY STOP button and check it afterwards
- It has to be connected acc. to the connection scheme [chapter 9.2.3 "Keypad connection scheme" on page 15](#)
- The max. load current is 500 mA

**9.2.2 Overview**

Name at housing	Connection type	Connector type (Integrated)	Mating connector or cable (from outside)
X2	Keypad connection	Phoenix, pin contact strip, 6-pin, MCV 1,5/6-G-3,5	Phoenix socket strip, 6-pin, FK-MCP 1,5/6-ST-3,5
X3:	Keypad connection	Phoenix, pin contact strip, 10-pin, MCV 1,5/10-G-3,5	Phoenix socket strip, 10-pin, FK-MCP 1,5/10-ST-3,5

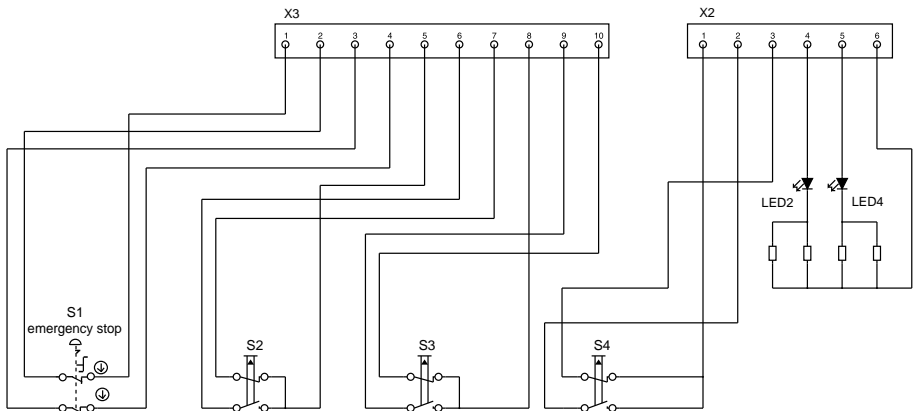
**Tab. 9-6:** Keypad interfaces**9.2.3 Keypad connection scheme****Fig. 9-5:** Connection scheme of the keypad

## 9.2.4 Pin assignment of the keypad

Pin	Function
1	S1 (E-STOP) N/C contact 1
2	S1 (E-STOP) N/C contact 1
3	S1 (E-STOP) N/C contact 2
4	S1 (E-STOP) N/C contact 2
5	S2 (white key), N/O contact / N/C contact
6	S2 (white key) N/O contact
7	S2 (white key) N/C contact
8	S3 (black key), N/O contact / N/C contact
9	S3 (black key) N/O contact
10	S3 (black key) N/C contact

**Tab. 9-7:** Pin assignment of keypad X3

Pin	Function
1	S4 (blue key), N/O contact / N/C contact
2	S4 (blue key) N/O contact
3	S4 (blue key) N/C contact
4	LED2 in S2 (white key) +24V
5	LED4 in S4 (blue key) +24 V
6	LED2/LED4 0V

**Tab. 9-8:** Pin assignment of keypad X2

### **NOTICE**

Destruction of screw terminals, insufficient contact and loss of UL/CSA certification if no copper wire is used and/or wrong tightening torque.

For terminal connectors use copper wire only. Tighten the screws of the screw terminals with a torque of 2.25 lb in (0.25 Nm).

## 10 Mounting, demounting and electric installation

### 10.1 Housing dimensions

#### 10.1.1 Rexroth design

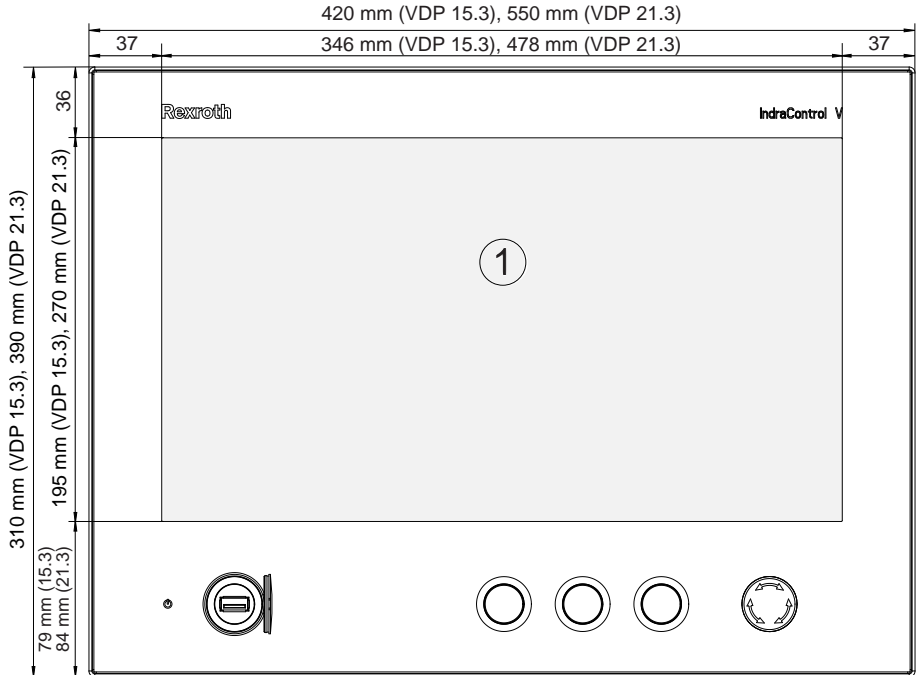

① Visual range of the display

**Fig. 10-1:** Housing dimensions of the front of the operating display VDP 15.3/VDP 21.3 in millimeters, Rexroth design

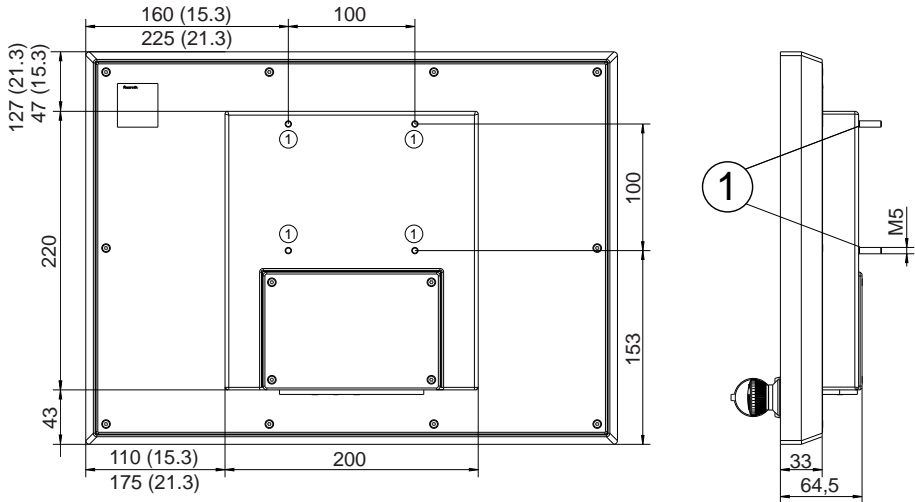

- ① VESA attachment with four M5 threaded bolts with nuts in a distance of 100 millimeters

**Fig. 10-2:** Housing dimensions of the back side of the operating display VDP 15.3/VDP 21.3 in millimeters, Rexroth design

## 10.2 Installation notes

- When installing the display, ensure an ergonomic operation. Additionally, ensure that all moving machine components can be seen by the operator at any time
- Avoid installation positions exposed to direct UV and sunlight. Direct sunlight reduces the readability at the screen and causes additional warming
- The LED display on the operator panel must not be covered.
- Wire all cables in loops. Use strain reliefs for all cables
- To maintain the degree of protection IP 65, use only a cable bushing of the sealing gasket fitting to the cable cross sections. If required, use the fitting sealing gasket
- Do not lay the CDI cables in parallel to the motor cables or other noise sources as otherwise the CDI connection may be disturbed. Keep as much distance as possible to noise sources

## 10.3 Mounting

**NOTICE**

Loss of IP degree of protection due to incorrect mounting as well as damaged or insufficiently mounted covers.

- Select the cable bushing at the sealing gasket fitting to the cable cross section
- The sealing of the cover must not be damaged
- Mount the cover correctly and fasten the screws with the correct mounting torque



The operator terminals can be attached to a standardized VESA support arm provided by different manufacturers.

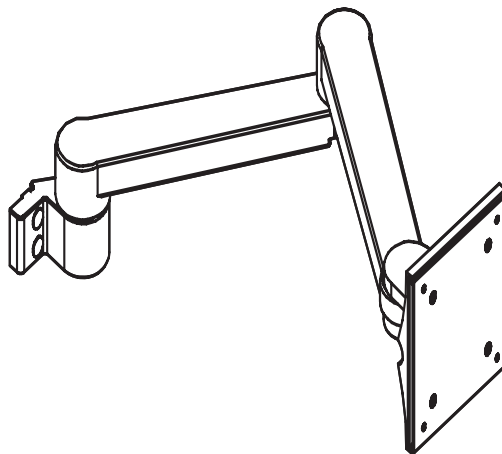

**Fig. 10-3:** VESA support arm

Mount the operating display as follows:

1. Open the housing cover by loosening the screws. Refer to the following figure [10-4](#).

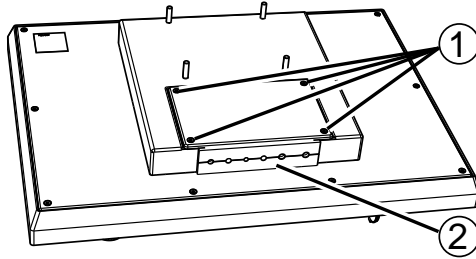

- ① Screwing the housing cover
- ② Rubber grommet

**Fig. 10-4:** Opening housing cover

2. Remove the rubber grommet.
3. For the plugs X2 and X3 of the keypad, remove the protective cover. Refer to the figure 10-5.

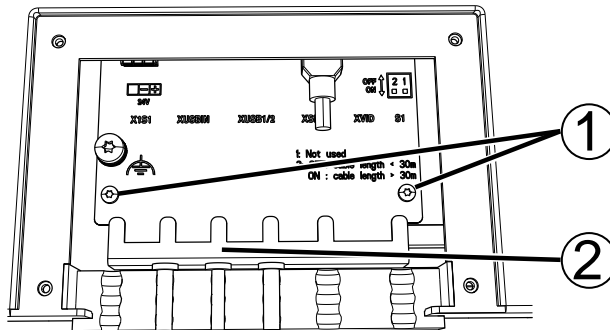

- ① Screwing the protective cover
- ② Holding devices for cable ties for strain relief

**Fig. 10-5:** Remove protective cover

4. Connect the plugs X2 and X3. Refer to the figure 10-6. For the pin assignment, refer to [chapter 9.2.4 "Pin assignment of the keypad" on page 16](#).

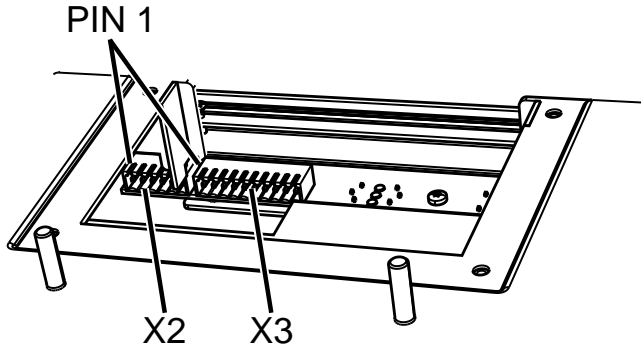

**Fig. 10-6:** Plugs X2 and X3

5. Tighten the protective cover again using screws. Refer to the figure 10-5.
6. Connect the cables and wire them through the sealing gasket. Ensure that the rubber grommet tightly encloses the cables.
7. Use the cable ties for strain relief. Refer to the figure 10-7.

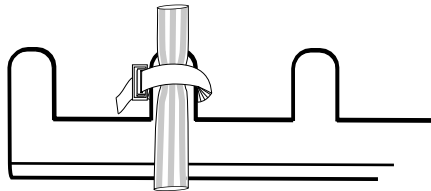

**Fig. 10-7:** Strain relief using cable ties

8. Tighten the housing cover.

### **NOTICE**

**Mechanic damage due to incorrect mounting torque.**

Tighten the screws and nuts with the corresponding torque according to the following table.

Threads	Mounting torques
M2.5	0,4 Nm
M3	0,7 Nm
M4	1,4 Nm
M5	1.0 Nm

**Tab. 10-1:** Mounting torques

## 10.4 Demounting

1. Disconnect the operating display.
2. Remove all connected cables.
3. Loosen the screws of the support arm fastening.

## 10.5 Electrical wiring

### 10.5.1 Connecting operating display to control cabinet

#### Connection diagram

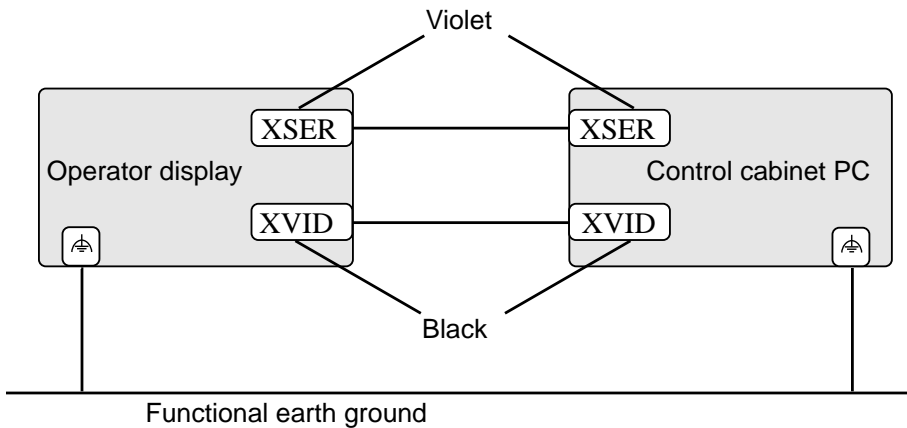

**Fig. 10-8:** Wiring operating display with control cabinet PC

#### Connection

1. Connect the functional earth.



2. Connect the violet RJ45 data interface "XSER" at the operating display to the RJ45 data interface "XSER" at the control cabinet PC.
3. Connect the black RJ45 image data interface "XVID" at the operating display to the RJ45 image data interface "XVID" at the control cabinet PC.

**NOTICE****Material damages to electronics due to missing functional earth!**

Ensure that the functional earth is connected, as otherwise the electronics can be destroyed by a potential difference between the VDP and the PC if the voltage supply is interrupted to only one device and re-established. A direct connection between functional earth and operating display VDP xx.3 and the control cabinet VPB 40.3 is recommended. If the functional earth is wired at a neutral point, also connect the control cabinet PC (VPB 40.3, VSB 40.3) to this neutral point.



When wiring CDI cables with a diameter of 7.4 mm, observe the following bending radii:

- Radius when bended once during wiring:  $4 \times$  cable diameter
- Minimum bending radius when moved permanently:  $8 \times$  cable diameter
- Optimum bending radius when moved permanently:  $12.5 \times$  cable diameter

**Malfunction due to mechanical forces on the CDI cables.**

Avoid mechanical stress (tensile, compressive, torsional and lateral forces) caused by plugs to the RJ45 socket.

**Malfunction operation due to interchanged CDI cables.**

To clearly identify cables, label them, e.g. with cable markers or clips.



The maximum cable length depends on the display resolution:

- Up to 50 meters:  $1920 \times 1080$  pixels (only VDP 21.3)
- Up to 70 meters:  $1366 \times 768$  pixels (only VDP 15.3)

Longer cables can be used when using a Y-repeater. Also refer to the operating instruction of the Y-repeater, parts number [R911336973](#).

**Screen output interference due to VDP device exchange at runtime if the resolution of the exchanged device is different.**

The display resolution is detected only once after switching on the control cabinet PC. Consequently, if a VDP is plugged in and then removed or if a VDP is connected at control cabinet PC startup, only a VDP with the same resolution can be connected again. Thus, it is ensured that the screen output at the connected VDP is executed automatically without changing the screen output to the VDP via keyboard.



### Malfunctions caused by using inappropriate cables.

Use only cables listed in [chapter 5 "Spare parts, accessories and wear parts" on page 5.](#)

## 10.5.2 Connecting operating display to 24 V voltage supply

### Connection diagram

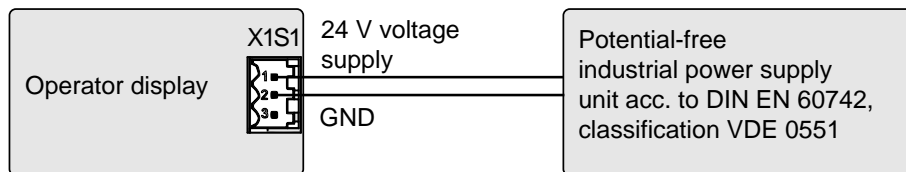

Fig. 10-9: Cabling of operating display and 24 V voltage supply

### Connection

1. Connect the "X1S1" interface for the 24 V voltage supply to the industrial power supply unit.

Use a 24 V industrial power supply unit acc. to DIN EN 60742, classification VDE 0551, for example "VAP01.1H-W23-024-010-NN" (parts number R911171065) for the voltage supply.

### **NOTICE**

In case of greater distances between VDP and control cabinet PC, equalizing currents may flow when using a non-isolated power supply unit as pin 2 is internally connected to the housing.

In this case, use an isolated power supply unit.

### UPS



The display immediately darkens in case of a power failure if the operating display is directly connected to the 24 V supply voltage without UPS. The user cannot execute any actions via the operating display during the shutdown of the control cabinet PC.

If the operating display is connected together with the control cabinet PC to the "24 V Out" of the external UPS, the user can still access the operating display during shutdown due to a power failure.

### 10.5.3 Connection diagram

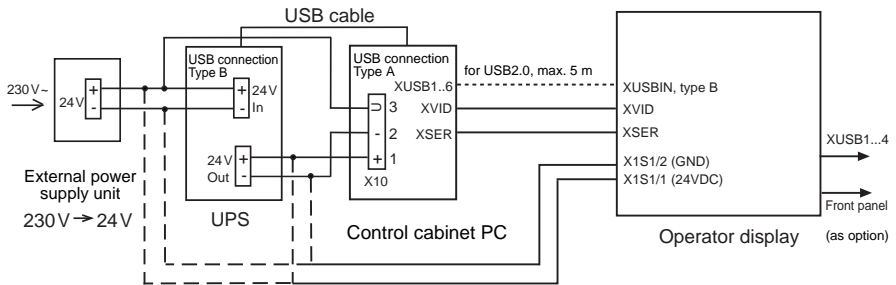

**Fig. 10-10:** Connection diagram with power supply unit, UPS, control cabinet PC and operating display

### 10.5.4 Recommendation for the assembly of CDI cables with long lengths in an interference-prone environment

#### General information

The CDI cable is a connection cable with RJ45 connector to connect the CDI interface of the control cabinet PC to the remote operating display or the Y-repeater.

These assembly recommendations facilitate an optimized signal transmission. In particular in case of great cable lengths and distances between the control cabinet PC and the remote operating display, ensure that the cable is installed correctly and the shield connected correctly.

#### Cable installation

Refer to the following information on the cable installation:

- Keep the maximum possible distance to interference-prone cables and lines
- Limit parallel routing with other lines
- Keep the maximum possible distance to sources of interference such as drives and frequency converters
- Mechanical protection against tensile and compressive load on the cable
- Comply with the permissible bending and torsional stress of the cable
- Avoid dirt at the RJ45 plug which can occur while drawing in the cables in the system.

#### Potential equalization

Ensure that no compensating current flows via the cable shield of the CDI cables while installing the potential equalization between device and machine parts.

## Shielding

The shielding is an important component of the CDI cable. The shielding is used to shield the data wires in the cable against electrical interferences of the environment. The shielding has to be connected to the potential equalization of the devices to shield the data wires. In most cases, a connection via the RJ45 connectors is sufficient.

Clean the shielding areas of the RJ45 plug prior to plugging them in.



Fig. 10-11: RJ45 connector shielding areas

### Additional shielding connection in case of strong electrical interferences and long cables

In case of strong electrical interferences and long cables, it can be required to additionally connect the shielding to the earthing potential.

Refer to the following information when installing the additional shielding connection:

- Assemble suitable EMC shielding clamps close to the control cabinet PC, the remote operating display or the Y-repeater
- Ensure that the CDI cable is not crimped when connecting the shielding to the potential equalization
- Avoid mechanic load (compressive load, tensile load) on the plug
- Use EMC shielding clamps compatible with the cable diameter. Crimping of the cable impairs the electrical properties of the CDI cable.

Comply with the following steps while mounting the shield connection:

1. Only remove the CDI cable jacket on the length required for the connection.



The CDI cable is sensitive to mechanical load where the jacket was removed. Ensure that the CDI cable shielding is not damaged when removing the cable jacket.



**Fig. 10-12:** CDI cable with RJ45 plug



**Fig. 10-13:** CDI cable with partially removed jacket

2. Remove the foil shield.



CDI cables are equipped with an additional foil shield. The foil shield must not be used for connection to the shielding clamp. The foil shield is usually plastic-coated on one side for an improved stability. The plastic coating insulates the foil shield.

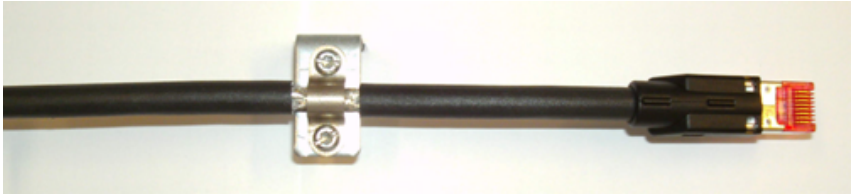

**Fig. 10-14:** Foil shield of the CDI cable



**Fig. 10-15:** Foil shield removed

3. Fasten cable with EMC shielding clamp.



**Fig. 10-16:** CDI cable with shielding clamp

More shielding clamps:



- ① Manufacturer: Ikotec
- ② Manufacturer: Phoenix Contact

**Fig. 10-17:** Shielding clamps

## 11 Commissioning

The product can be used directly. No configuration is required.

## 12 Device description

### 12.1 General information

Depending on the operation (glove or finger), the multi-touch configuration is different. Different parameter sets (standard, glove and extreme EMC-loaded operation) of the multi-touch controller can be loaded with the IPC maintenance tool. For special use cases, contact the Bosch Rexroth service.

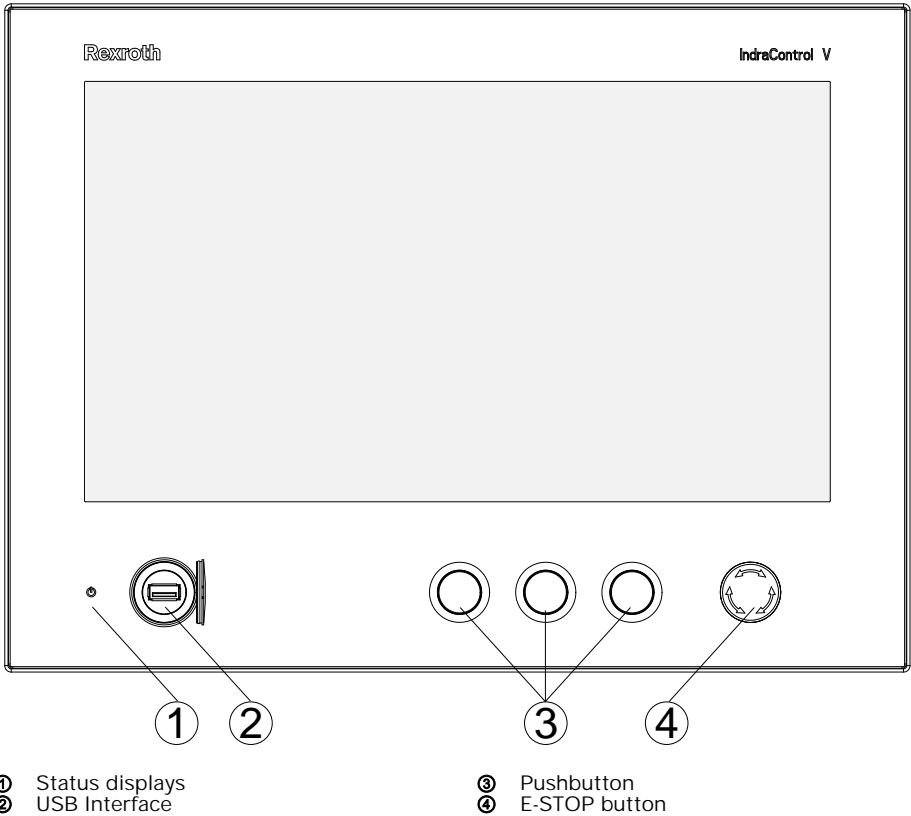



Fig. 12-1: Front view

## 12.2 Operating and error displays

An LED for the operating display is located in the lower part of the front panel.

Symbol, LED	Display	Meaning	Action
 Power	LED green	Normal operation With Y-repeater: This VDP is the active device	-
	LED off	No supply voltage DC 24 V	Check supply voltage
	LED flashing green	No serial connection to the control cabinet PC	Check cables
		With Y-repeater: This VDP is not the active device	No action

Tab. 12-1: LED for operating and error display on the front panel

## 13 Error causes and troubleshooting

For information on the error display on the front panel, refer to [chapter 12.2 "Operating and error displays" on page 29](#).

Error	Troubleshooting
No screen visible	<ul style="list-style-type: none"> <li>● Connect the supply voltage and check the X1S1 connection</li> <li>● Connect the CDI cable correctly and check XVID and XSER</li> <li>● Set the screen output in the graphics driver to "VDP"</li> <li>● Switch on the voltage at the operating display before or with the control cabinet PC</li> </ul>
Distorted display due to incorrect display resolution	<ul style="list-style-type: none"> <li>● Set the correct display resolution in the graphics driver</li> <li>● Restart the control cabinet PC</li> </ul>
The USB flash drive does not work, although other USB devices work	<ul style="list-style-type: none"> <li>● Set the DIP switch on the VDP to &lt;30 m</li> <li>● Note: USB memory sticks can only be used up to a cable length of 30 meters</li> </ul>
USB devices and touch screen do not work	<ul style="list-style-type: none"> <li>● Set the DIP switch appropriately to the cable length</li> </ul>

Tab. 13-1: Error causes and troubleshooting

## 14 Maintenance

### 14.1 General information

**NOTICE**

Loss of IP degree of protection due to incorrect maintenance.

Ensure the IP degree of protection during maintenance!

### 14.2 Display

The backlight is subject to wear, see [chapter 5.6 "Wear parts" on page 7](#).

A fading backlight causes a progressive deterioration display readability. Thus, a replacement is necessary. For further information please contact the Bosch Rexroth Service.

### 14.3 Cleaning notes

**NOTICE**

Dissolving front glass sealing with solvent!

- Do not use solvents
- Do not use high pressure cleaning device

### 14.4 Regular maintenance tasks

- Check all plug and terminal connections of the components for proper tightness and possible damage at least once a year
- Check that no cables are broken or pinched
- Replace damaged parts immediately

## 15 Ordering information

### 15.1 Accessories and spare parts

For ordering information on accessories and spare parts, refer to [chapter 5 "Spare parts, accessories and wear parts" on page 5](#).

## 15.2 Type code

Short text column	1	2	3	4	5	6	7	8	9	10	11	12	13	14	15	16	17	18	19	20	21	22	23
Example:	V	D	P	1	5	.	3	C	L	N	-	D	1	-	N	N	-	N	N				
<b>Product</b>																							
VDP .....																							
<b>Line</b>																							
15 .....																							
<b>Design</b>																							
3 .....																							
<b>Front panel and display</b>																							
<b>Rexroth design</b>																							
15,6", Multitouch .....																							
15,6", Multitouch .....																							
<b>Customized design</b>																							
Bosch: 15,6", Multitouch .....																							
<b>Additional option</b>																							
None .....																							
<b>Operator panel interface</b>																							
CD1 .....																							
<b>Interface</b>																							
None .....																							
<b>Other design</b>																							
None .....																							
In aluminium housing .....																							
In aluminium housing (zone A) .....																							
In aluminium housing (zone A+B+C) .....																							
In stainless steel housing (zone A) .....																							
In stainless steel housing (zone A+B+C) .....																							

Notes:

- 1) Front GA not possible with other design C2, C3, C4 and C5
- 2) Front CL not possible with other design CH

Fig. 15-1: Type code VDP 15.3

Short text column	1	2	3	4	5	6	7	8	9	10	11	12	13	14	15	16	17	18	19	20	21	22	23
Example:	V	D	P	2	1	.	3	C	N	N	-	D	1	-	N	N	-	N	N				

**Product**

VDP ..... = VDP

**Line**

21 ..... = 21

**Design**

3 ..... = 3

**Front panel and display**

**Rexroth design**

21,5", Multitouch ..... = GC <sup>1)</sup>

21,5", Multitouch vertical ..... = GK <sup>2)</sup>

**Customized design**

Bosch: 21,5", Multitouch ..... = CN <sup>3)</sup>

**Additional option**

None ..... = N

**Operator panel interface**

CDI ..... = D1

**Interface**

None ..... = NN

**Other design**

None ..... = NN

In aluminium housing ..... = CH <sup>3)</sup>

In aluminium housing (zone A) ..... = C2 <sup>1)</sup>

In aluminium housing (zone A+B+C) ..... = C3 <sup>1)</sup>

In stainless steel housing (zone A) ..... = C4 <sup>1)</sup>

In stainless steel housing (zone A+B+C) ..... = C5 <sup>1)</sup>

Notes:

- 1) Front GC not possible with other design C2, C3, C4 and C5
- 2) Front GK not possible with other design CH, C2, C3, C4 and C5
- 3) Front CN not possible with other design CH

Fig. 15-2: Type code VDP 21.3

## 16 Disposal

### 16.1 Return

For disposal, our products can be returned free of charge. However, the products must be free of remains like oil and grease or other impurities.

Furthermore, the products returned for disposal must not contain any undue foreign substances or components.

Send the products free of charge to the following address:

Bosch Rexroth AG  
Electric Drives and Controls  
Bürgermeister-Dr.-Nebel-Straße 2  
D-97816 Lohr am Main, Germany

### 16.2 Packaging

The packaging material consists of cardboard, plastics, wood or styrofoam. Packaging material can be recycled anywhere.

For ecological reasons, please do not return empty packages to Bosch Rexroth.

## 17 Service and support

Our worldwide service network provides an optimized and efficient support. Our experts offer you advice and assistance should you have any queries. You can contact us **24/7**.

### Service Germany

Our technology-oriented Competence Center in Lohr, Germany, is responsible for all your service-related queries for electric drive and controls.

Contact the **Service Hotline** and **Service Helpdesk** under:

Phone: **+49 9352 40 5060**  
Fax: **+49 9352 18 4941**  
E-mail: [service.svc@boschrexroth.de](mailto:service.svc@boschrexroth.de)  
Internet: <http://www.boschrexroth.com/>

Additional information on service, repair (e.g. delivery addresses) and training can be found on our internet sites.

### Service worldwide

Outside Germany, please contact your local service office first. For hotline numbers, refer to the sales office addresses on the internet.

### Preparing information

To be able to help you more quickly and efficiently, please have the following information ready:

- Detailed description of malfunction and circumstances
- Type plate specifications of the affected products, in particular type codes and serial numbers
- Your contact data (phone and fax number as well as your e-mail address)



## Index

### 0 ... 9

- 24 V DC voltage supply..... 12
- 24 V voltage supply..... 12

### A

- Accessories..... 5
- Ambient conditions..... 7
- ANSI Z535.6-2006..... 4

### B

- Backlight..... 7
- Bending radii..... 23

### C

- Cable installation..... 25
- Cable installation CDI cable..... 25
- Cables..... 6
- CDI cable, long..... 25
- CDI interface..... 6, 14
- CE marking..... 10
- Characteristic values, optical..... 9
- Cleaning notes..... 31
- Commission..... 28
- Complaints..... 2
- Connecting cables to control cabinet PC..... 6
- Connector panel..... 11
- Criticism..... 2
- Customer Feedback..... 2

### D

- Declaration of conformity..... 10
- Demounting..... 17, 22
- Device description..... 28
- DIP switch..... 13
- Disposal..... 34
- Documentation overview..... 1
- Documents, related..... 2

### E

- E-STOP button
  - Service life, characteristic value B10d..... 9
- E-STOP standards..... 10
- Electrical interferences..... 26

- Electrical wiring..... 22
- EMC interferences..... 25
- EMC shielding clamp..... 27
- Error causes..... 30
- Error displays..... 29
- External 24 V power supply unit..... 6

### F

- Faulty pixels..... 9
- Feedback..... 2

### H

- Hazard warnings..... 3
- Helpdesk..... 34
- Hotline..... 34
- Housing dimensions..... 17

### I

- Input system, characteristic values 9
- Installation notes..... 18
- Instructions, related..... 2
- Intended use..... 5
- Interface
  - XVID interface..... 14
- Interfaces..... 11
  - Keypad..... 14, 20
  - XUSB interfaces..... 13
  - XVID interface..... 14
- Interference-prone environment... 25

### K

- Keypad..... 14
  - Connection scheme..... 15
  - Pin assignment..... 16
- Keypad connection scheme..... 15

### L

- LED..... 29

### M

- Maintenance..... 31
- Mounting..... 17, 19
- Multi-touch front, characteristic values..... 9

<b>N</b>		Type code.....	32
24 V power supply unit.....	6	Type plate.....	2
<b>O</b>		<b>U</b>	
Operating and error displays.....	29	UL/CSA Certified.....	11
Optical characteristic values.....	9	Uninterruptible power supply.....	6
Ordering information.....	31	UPS.....	6
<b>P</b>		USB interfaces.....	13
Packaging.....	34	Use, intended.....	5
Pin assignment keypad.....	16	<b>V</b>	
Pixel errors.....	9	VESA support arm.....	19
Power supply unit.....	6	Voltage supply.....	12, 24
Product identification.....	2	Voltage supply (24 V DC).....	12
<b>R</b>		<b>W</b>	
Return.....	34	Warnings.....	3
Rubber grommet.....	7	Wear parts.....	5, 7
<b>S</b>		Wiring, electrical.....	22
S1 DIP switch.....	13	<b>X</b>	
Safety alert symbol.....	4	X2, X3.....	20
Safety instructions.....	3	XUSB interfaces.....	13
Scope of delivery.....	3	<b>Y</b>	
Scope of the documentation.....	1	Y-repeater.....	2, 5, 6
Sealing.....	7		
Service hotline.....	34		
Service life			
Backlight.....	7		
Service life, characteristic value B10d.....	9		
Shielding CDI cable.....	25		
Shielding clamps.....	28		
Signal words.....	4		
Spare parts.....	5		
Standards.....	9		
Suggestions.....	2		
Supply voltage.....	24		
Support.....	34		
Symbols.....	4		
<b>T</b>			
Target groups.....	1		
Technical data.....	8		
Voltage supply.....	12		
TFT.....	9		
Troubleshooting.....	30		





## Notes

**Bosch Rexroth AG**

Electric Drives and Controls

P.O. Box 13 57

97803 Lohr, Germany

Bgm.-Dr.-Nebel-Str. 2

97816 Lohr, Germany

Tel. +49 9352 18 0

Fax +49 9352 18 8400

[www.boschrexroth.com/electrics](http://www.boschrexroth.com/electrics)



R911342319