

3D Viewer App

Browser-based 3D Kinematic Simulation
for ctrlX CORE

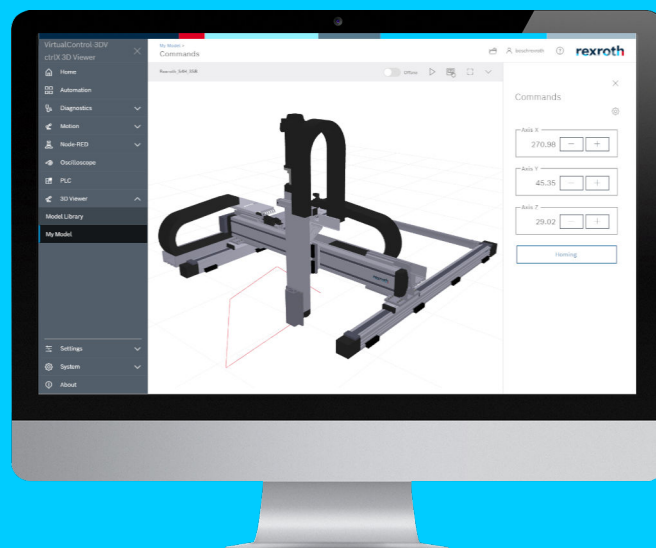

Copyright

© Bosch Rexroth AG 2022

All rights reserved, also regarding any disposal, exploitation, reproduction, editing, distribution, as well as in the event of applications for industrial property rights.

Liability

The specified data is intended for product description purposes only and shall not be deemed to be a guaranteed characteristic unless expressly stipulated in the contract. All rights are reserved with respect to the content of this documentation and the availability of the product.

DOK-XCORE*-3D*VIEWER**-AP03-EN-P

DC-IA/EPI5 (TaDo/MePe)

Table of contents

1	About this documentation	5
2	Important directions on use	7
2.1	Intended use.	7
2.1.1	Introduction.	7
2.1.2	Areas of use and application	7
2.2	Unintended use.	8
3	Safety instructions	9
4	Introduction and overview	11
5	Prerequisites	13
6	Installation	15
7	Menu “Model Library”	17
7.1	Uploading model.	17
7.2	Opening model.	18
7.3	Deleting model.	19
8	Menu “My Model”	21
8.1	Mode “Disconnected”.	21
8.2	Dialog “Commands”.	21
8.3	Mode “Connected”.	23
8.4	Dialog “Settings”.	26
8.5	Menu.	28
8.6	Mode “Full screen”.	33
9	Related documentation	35
9.1	Overview.	35
9.2	ctrIX AUTOMATION.	35
9.3	ctrIX WORKS.	35
9.4	ctrIX CORE.	36
9.5	ctrIX CORE apps.	36
10	Service and support	39
11	Index	41

1 About this documentation

Editions of this documentation

Edition	Release date	Note
01	2022-02	First edition Version 3DV-V-0112
02	2022-04	Version 3DV-V-0114 New: <ul style="list-style-type: none">➔ Chapter 8.4 Dialog “Settings” on page 26 Revision: <ul style="list-style-type: none">➔ Chapter 8.5 Menu on page 28: “ Perspective” button supplemented
03	2022-09	Version 3DV-V-0116 Revision: <ul style="list-style-type: none">➔ Chapter 8.3 Mode “Connected” on page 23➔ Chapter 8.4 Dialog “Settings” on page 26➔ Chapter 8.5 Menu on page 28

2 Important directions on use

2.1 Intended use

2.1.1 Introduction

Rexroth products are developed and manufactured to the state-of-the-art. The products are tested prior to delivery to ensure operational safety and reliability.

▲ WARNING

Personal injury and damage to property due to incorrect use of products!

The products may only be used as intended.

Failure to use the products as intended may cause situations resulting in property damage and personal injury.

NOTICE

Damages resulting from unintended use

Rexroth As the manufacturer does not assume any warranty, liability or compensatory claims for damages resulting from unintended use of the products. The user alone shall bear the risks of an unintended use of the products.

Before using Rexroth products, make sure that all the prerequisites for an intended use of the products are met:

- Personnel that in any way, shape or form uses Rexroth products must first read and understand the relevant safety instructions and be familiar with their intended use
- Leave hardware products in their original state, i.e., do not make any structural modifications. It is not permitted to decompile software products or alter source codes
- Do not install damaged or defective products or commission them
- It has to be ensured that the products have been installed as described in the relevant documentation

2.1.2 Areas of use and application

Products of the ctrlX series are suitable for Motion/Logic applications.

NOTICE

Products of the ctrlX series may only be used with the accessories, mounting parts, and other components specified in this documentation. Components that are not expressly mentioned must neither be attached nor connected. The same applies to cables and lines.

Only to be operated with the hardware component configurations and combinations expressly specified and with the software and firmware specified in the corresponding documentations and functional descriptions.

Products of the ctrlX series are suitable for single-axis as well as for multi-axis drive and control tasks. Device types with different equipment and interfaces are available for using the system in specific applications.

Typical areas of application:

- Building automation
- IoT and Security Gateway or Device
- Handling & Robotic

Controls of the ctrlX CORE series may only be operated under the mounting and installation conditions, in the position of normal use and under the ambient conditions (temperature, degree of protection, humidity, EMC, etc.) specified in the related documentations.

2.2 Unintended use

"Unintended use" refers to using the ctrlX products outside of the above-mentioned areas of application or under operating conditions and technical data other than described and specified in the documentation.

ctrlX products must not be used if they are exposed to following conditions:

- Operating conditions that do not meet the specified ambient conditions. Operation under water, under extreme temperature fluctuations or under extreme maximum temperatures is prohibited
- Applications that have not been expressly authorized by Rexroth



3 Safety instructions

The Safety instructions contained in the available application documentation feature specific signal words (DANGER, WARNING, CAUTION or NOTICE) and, where required, a safety alert symbol (in accordance with ANSI Z535.6-2006).

The signal word is meant to draw the reader's attention to the safety instruction and identifies the hazard severity.

The safety alert symbol (a triangle with an exclamation point), which precedes the signal words DANGER, WARNING and CAUTION, is used to alert the reader to personal injury hazards.

The Safety instructions in this documentation are designed as follows:

 DANGER	In case of non-compliance with this safety instruction, death or serious injury will occur.
 WARNING	In case of non-compliance with this safety instruction, death or serious injury could occur.
 CAUTION	In case of non-compliance with this safety instruction, minor or moderate injury could occur.
NOTICE	In case of non-compliance with this safety instruction, property damage could occur.

4 Introduction and overview

The 3D Viewer app can be used for a 3D kinematic simulation on ctrlX CORE. It is a web-based application, i.e. it operates independently from the hardware and the operating system in a web browser. The required models include a description of the axis relations of a kinematics that also references the 3D geometries in STL format required for the model. ctrlX CORE provides the axis values on the ctrlX Data Layer to control the kinematic model. Combining a ctrlX CORE Virtual with the 3D Viewer app allows to design digital twins of machines and systems, e.g. for a virtual commissioning or programming and validating purposes.

5 Prerequisites

The following prerequisites have to be met to use the 3D Viewer app:

- 3D CAD data has to be in STL format
 - Create at least one STL file for each machine component that can move against other components
- Creation of the kinematic structure as tree structure saved in an XML file
 - Definition of the linear and rotary axes (directions, zero points, limit values, etc.)
 - Configuration of the transformation relations
 - Definition of the geometry elements with links on the STL files
 - The Bosch Rexroth service tool “Virtual Machine Builder” is required
- Configured axes in the ctrlX Data Layer via the Motion App or via scripts

6 Installation

License

The following license is required to operate the 3D Viewer app on the ctrlX CORE control:

Type code	Part number
SWL-XC*-3DV-3DVIEWER*****-NNNN	R911413191

Further information

- "ctrlX CORE - Runtime", Application Manual (R911403768), chapter [↔ Licenses – Overview](#)
- "ctrlX CORE - Runtime", Application Manual (R911403768), chapter [↔ ctrlX CORE – License information](#)

Installation

ctrlX CORE side navigation “*Settings → Apps*”

For more information on how to install the app, refer to the following chapters:

- "ctrlX CORE - Runtime", Application Manual (R911403768), chapter [↔ Apps – Basics](#)
- "ctrlX CORE - Runtime", Application Manual (R911403768), chapter [↔ Apps – Installation](#)

Call:

ctrlX CORE side navigation “*3D Viewer*”

7 Menu “Model Library”

Call:

ctrlX CORE side navigation “3D Viewer → Model Library”

Function

The model library is the starting point. The default model is a Cartesian 3D model. A customized 3D model can also be loaded.

7.1 Uploading model

There are two options to load the 3D model to ctrlX CORE:

- Via the “Select files” button in the “Model Library” dialog
- Dragging the XML and STL file and dropping it into the widget “Load machine models”

To load a customized model, select and load all files (one XML file and multiple *.STL files). The 3D model is saved in the configurations. It is then available as tile in the model library for further use.

The XML file and the STL files are created using the Virtual Machine Builder.

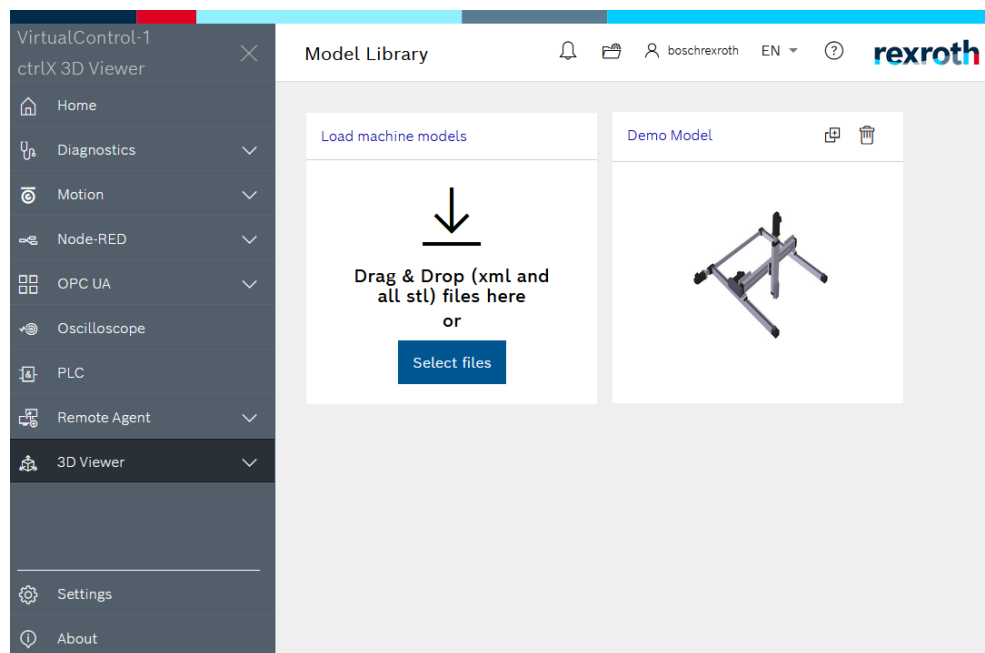
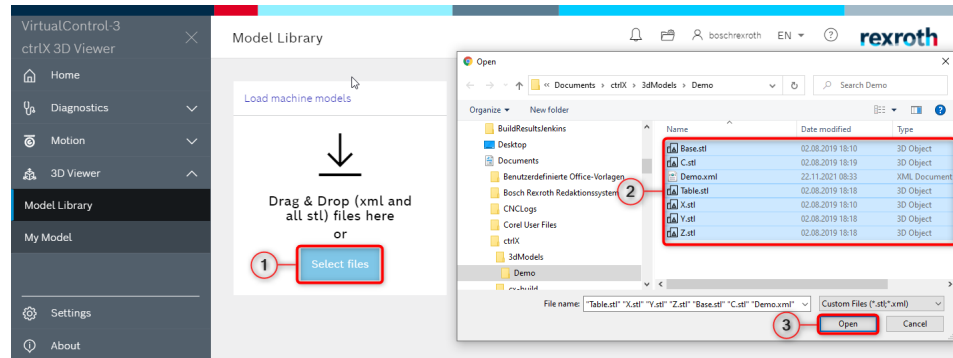

Fig. 1: Load machine models

Procedure via the “Select files” button

1. Click on “Select files”.

2. In the file selection dialog, navigate to the folder containing the model files, select all files (multiple STL files and one XML file) and click on “Open”.



➔ The selected model is loaded via the “My Model” menu.

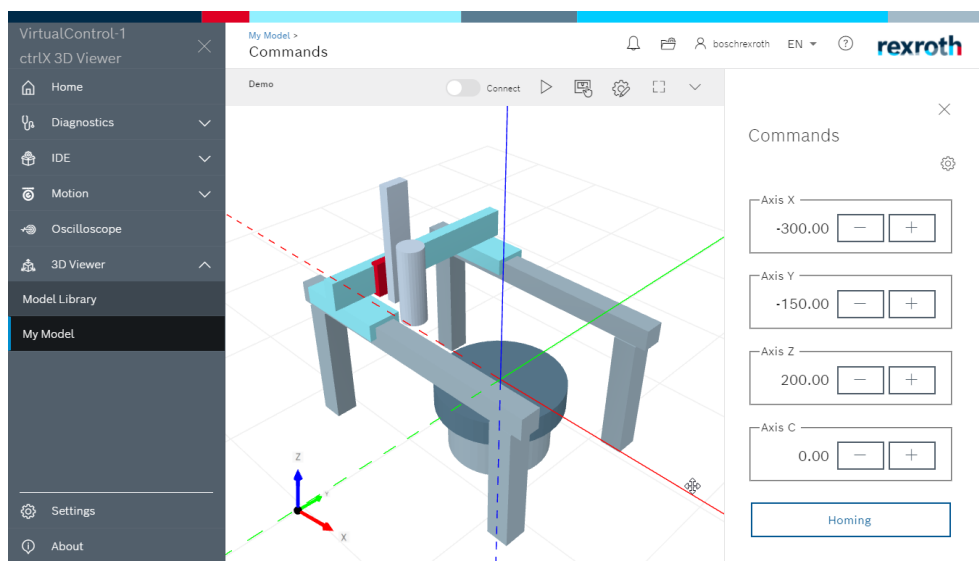

Fig. 2: “My Model” menu - Uploaded model

3. To show the uploaded model as new tile in the model library, click on the menu “Model Library”.

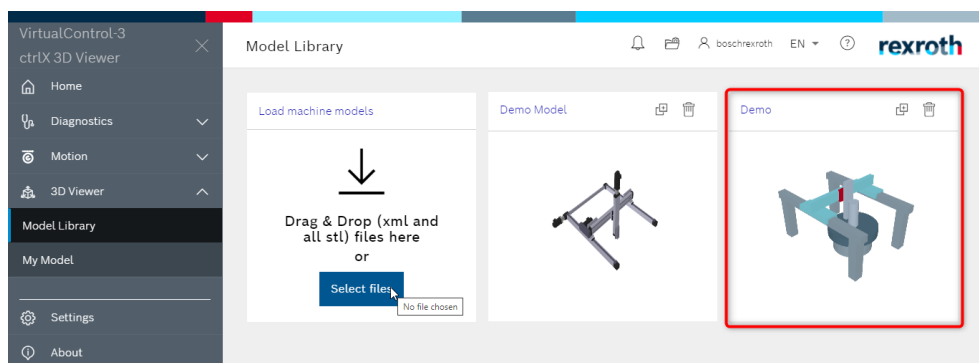



Fig. 3: “Model Library” menu - Tile of the model

7.2 Opening model

To open the model, click on the model name or the graphics and the model view is shown in the same window.

To open the model in the browser in an own tab, click on the  button.

7.3 Deleting model

To delete all files belonging to the model from the ctrlX device and from the model library, select the  button

8 Menu “My Model”

Call:

ctrlX CORE side navigation “3D Viewer → My Model”

8.1 Mode “Disconnected”

In the “Disconnected” mode, no command values of an axis are transferred to the 3D Viewer.

To move the model axes within the defined limit values from the XML file, select the ▷ button.

Special collision conditions are not part of this demo.

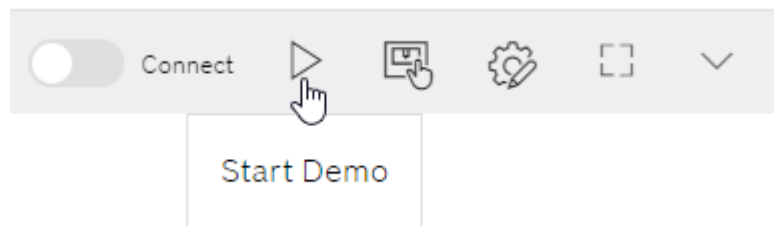



Fig. 4: Starting demo

8.2 Dialog “Commands”

The “Commands” dialog shows the axis positions. User inputs can move the machine model only in the Disconnected mode. The axes of the ctrlX device cannot be moved.

Call:

ctrlX CORE side navigation “3D Viewer → My Model → Sidebar Commands”

If the dialog is not shown, select .

Function

Function	Description
Jogging	The buttons "+" and "-" can be used to move the model axes within the limit values defined in the XML file
Homing	The model is reset to the initial positions defined in the XML file



Fig. 5: "Commands" dialog

The axis is moved by one increment consisting of a defined step width and the selected direction (+/-).

Select the Homing command to return all axes to the initial positions defined in the XML file.

8.3 Mode "Connected"

In the "Connected" mode, it is tried to attach the existing axis to the axis configuration of the ctrlX Motion. The model follows these positions and motions automatically. Limit values of the axis configuration are applied and the defined limit values from the XML file are ignored.

The jog commands and the reference commands are not available in the "Connected" mode.

An axis can only be attached to an axis in the ctrlX Data Layer/ctrlX Motion if its name and the name in the XML file do not differ. It is X, Y, Z and C in this example.

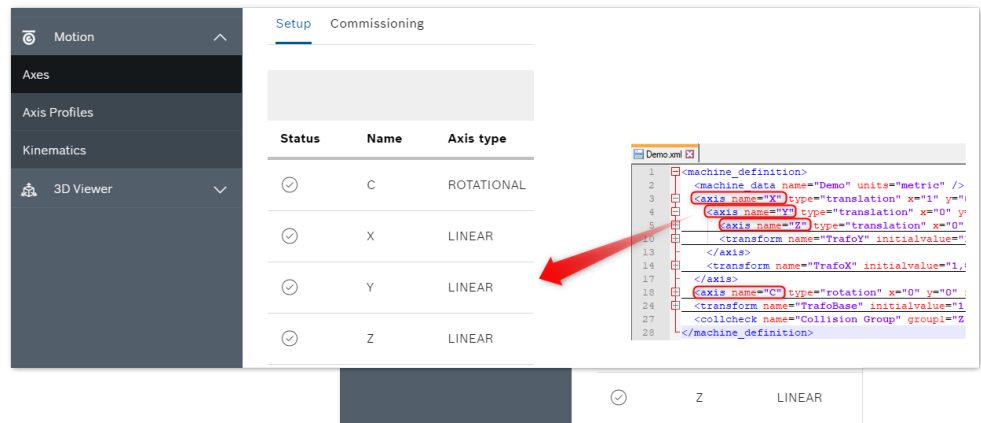

Fig. 6: Comparing axis names between the XML file and the ctrlX Data Layer/ctrlX Motion

If the axis names from the ctrlX Data Layer differ from the axis names from the XML file, the axes can be configured.

Commands

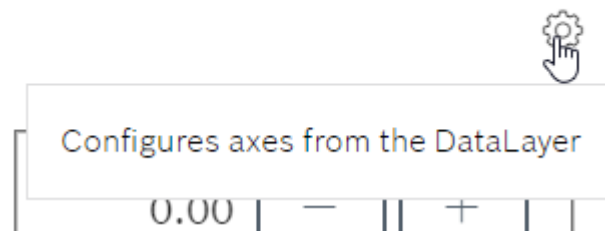

Fig. 7: Opens the dialog "Configure the Connection of Axes to DataLayer"

The dialog shows all model axes (axis from the XML file) and the respective axes of the ctrlX Data Layer.

Depending on the user rights, this option is enabled or disabled.

The axes X, Y1, Z and C are configured in the ctrlX Data Layer in the example and the axes X, Y, Z and C in the XML file of the model.

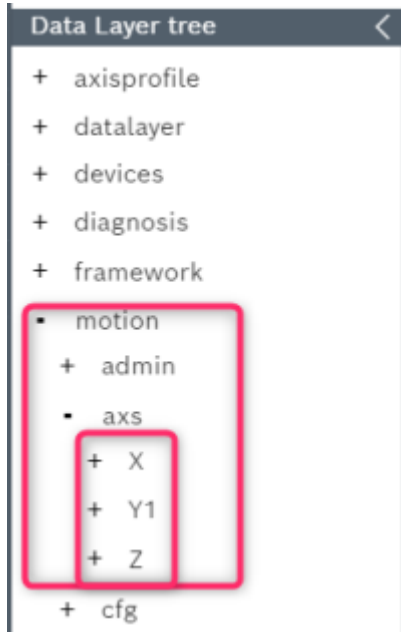

Fig. 8: Axis configuration in the ctrlX Data Layer

As the configurations do not match, the Y-axis of the model is not configured automatically. The line of the Y-axis is empty in the "Configure the Connection of Axes to DataLayer" dialog.

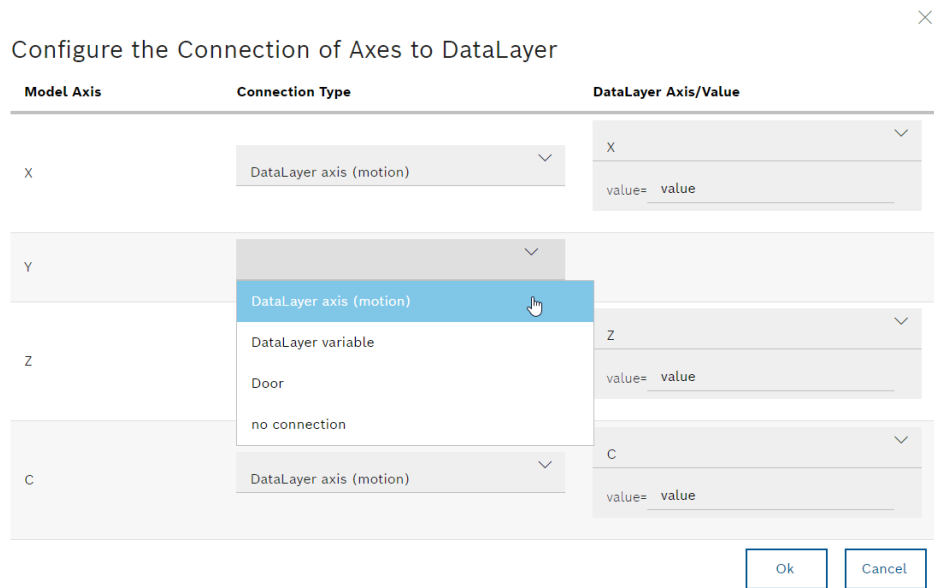

Fig. 9: Missing axis configuration of the Y-axis in the "Configure the Connection of Axes to DataLayer" dialog

To configure the Y-axis from the XML file as Y1 axis of the ctrlX Data Layer, select the connection type and the element for the data input in the Data Layer:

- "DataLayer axis (motion)":
The positions of the model axis are determined from the target positions of an axis to be selected in the right column.
- "DataLayer axis (motion)":
The positions of the model axis are determined by the values of a numeric variable in the Data Layer. In the right column, enter the path to the node into the Data Layer.

- "Door":
This connection type is intended for future development and does not apply to any current connection.
- "no connection":
This axis is not provided with any input and does not move in the "Connected" mode.

To modify the input value, use a mathematical expression in the "value=" input field.

Example

A variable can assume the values 0 and 1 corresponding to the rotary axis positions 0 and 180°:

value = value*180

The input value can be modified for the connection types DataLayer axis (motion) and DataLayer axis (motion) and should only be used for auxiliary axes.

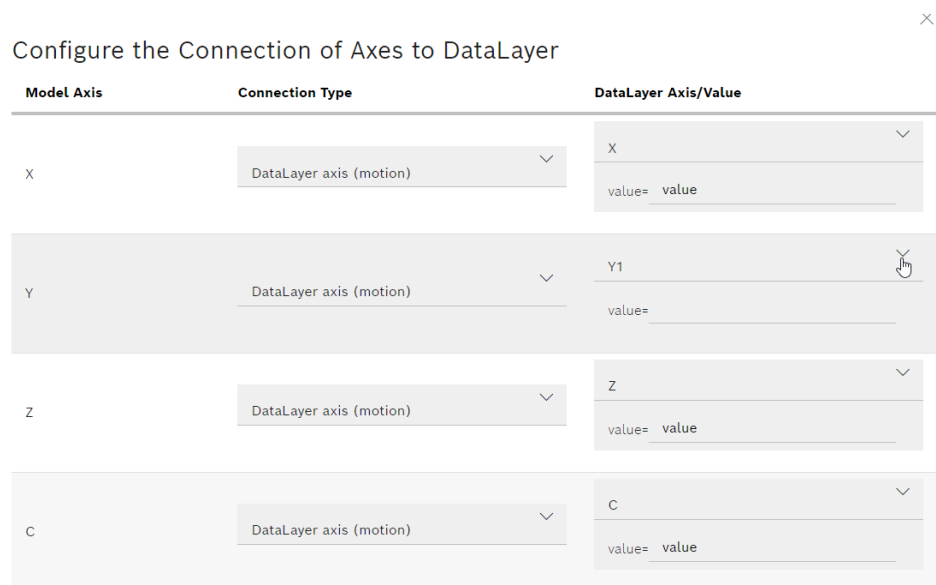

Fig. 10: Selecting the axis configuration for the Y-axis in the dialog "Configure the Connection of Axes to DataLayer"

Select the connection type and the correct axis or variable and confirm with "OK". If an axis should not be connected to the control, select "no connection".

When switching to the "Connected" mode, all connected axes change their position based on the data from the ctrlX Data Layer.

If the axis name in the ctrlX Data Layer and in the model differ, it is shown in the "Commands" dialog.



Fig. 11: Display of different axis names in the "Commands" dialog

8.4 Dialog “Settings”

Machine-specific and graphic settings can be made in the “Settings” dialog.

Call:

ctrlX CORE side navigation “3D Viewer → My Model → Sidebar ” “Settings”

If the dialog is not shown, select .

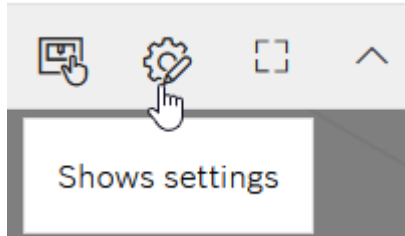

Fig. 12: Showing the “Settings dialog”

Function of the “Toolpath” tab

The tab “Toolpath” allows for every tool node in the model separate setting options for the tool path.

Function	Description
Collapsing and expanding the settings for a tool node	Use the buttons ^ and v behind the name of a tool node to expand or collapse hide the assigned settings.
“useDataLayer”	Enabling the switch makes additional input elements visible to dynamically modify the line type of the tool path.
“DataLayer variable”	Path of the Data Layer variable. Its value determines the line type.
“Expression”	Mathematical expression consisting of the input variable "value". Its result determines the line type.
“Line Type (Negative or Zero)”	Line type for expression result less than or equal to zero. Either select a pointed line or no line.
“Color”	Clicking on the colored field opens a color selection dialog for the line color of the tool path.
“Visible”	The switch shows and hides the tool path. Tracking continues in case of invisibility.
“On top”	Use the switch to either draw the graphics of the tool path in the foreground (visible) or in the background (not visible).
“Toolpath length”	Maximum number of polygon edges of the tool path of all tool nodes. Use the buttons "+" an "-" for either a direct input or a step-by-step change.
“Save”	The changes are saved on the control and are applied permanently. The dialog is closed.
“Cancel”	The changes are applied temporarily within the website, i.e. until the image is rebuilt. The dialog is closed.

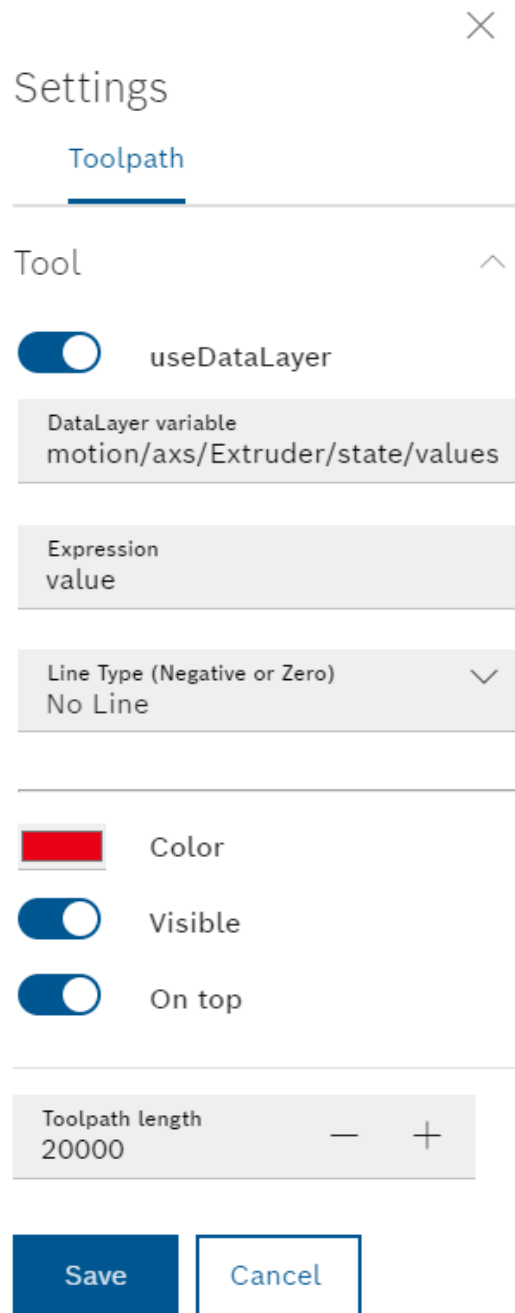

Fig. 13: Settings of the "Toolpath" tab

Function of the "Areas" tab

The "Areas" tab allows the graphic representation of individual safe zones and working areas.

This tab is only available if the working areas are defined and if the 3D Viewer in the "Connected" mode.

Function	Description
Collapsing and expanding the settings for an area	Use the buttons ^ and v behind the name of an area to expand or collapse the assigned settings.
"Type"	Type display

Function	Description
“Color”	Click on the colored field to open a color selection dialog for the color of the area.
“Transparency”	Use the switch to adjust the transparency of the area from transparent to covering.
“Visible”	Use the switch to switch on and off the visibility of an area.
“Save”	The changes are saved on the control and are applied permanently. The dialog is closed.
“Cancel”	The changes are applied temporarily within the website, i.e. until the image is rebuilt. The dialog is closed.

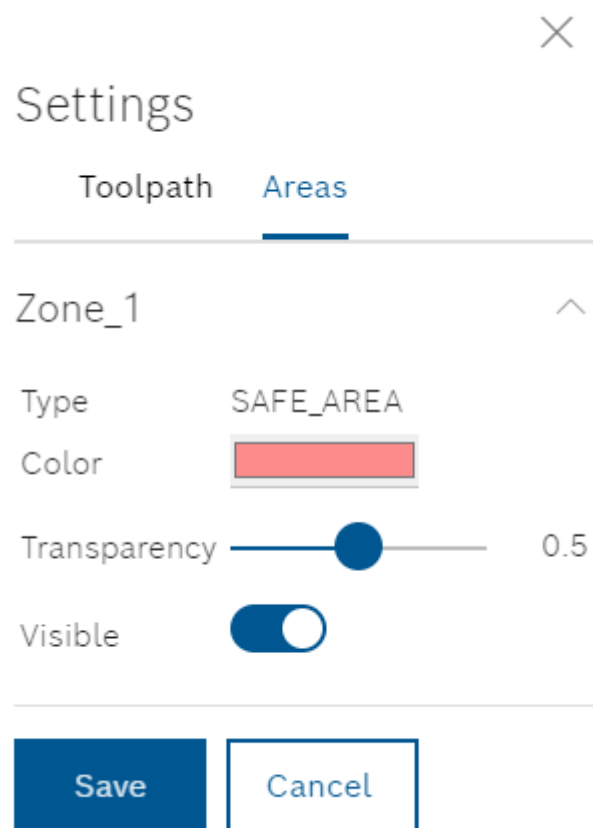



Fig. 14: Settings of the “Areas” tab

8.5 Menu

Call:

ctrIX CORE side navigation “3D Viewer → My Model → Tab bar”

Function

The menu is hidden by default. To open the menu, select  in the command bar.

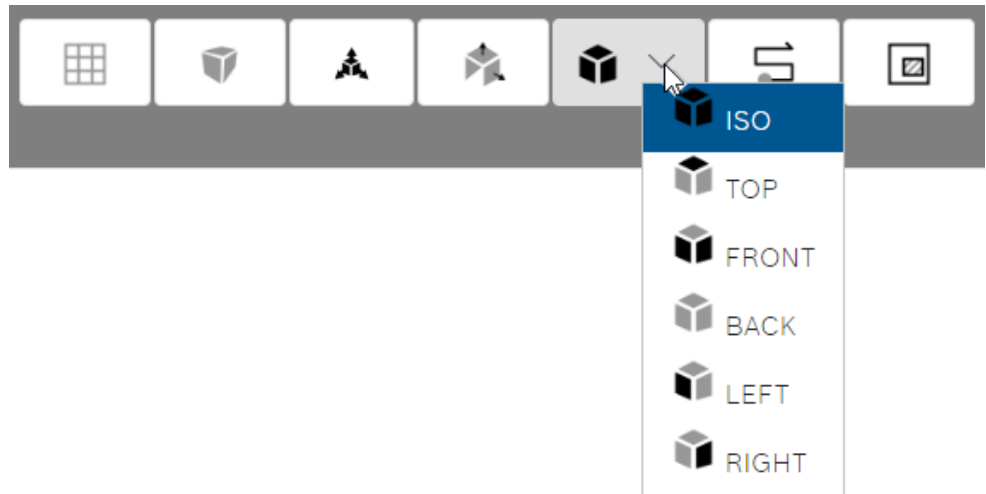

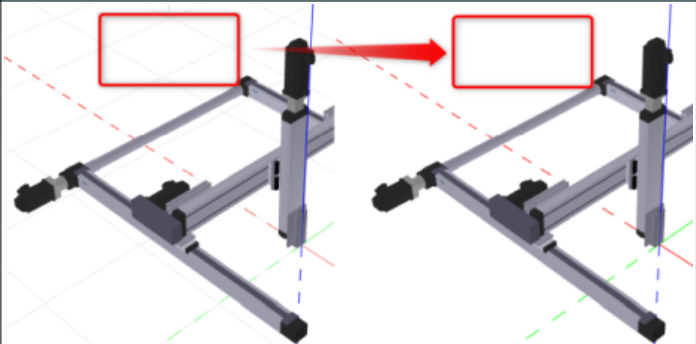

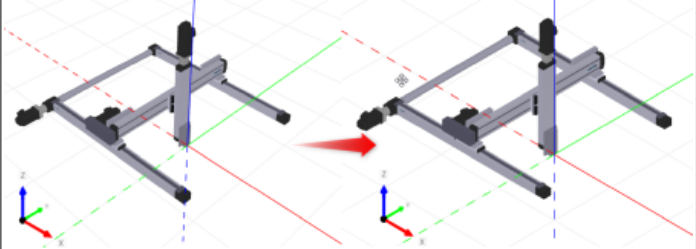

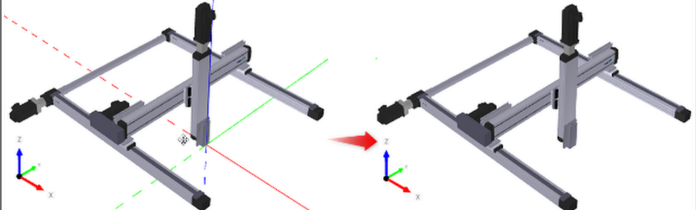

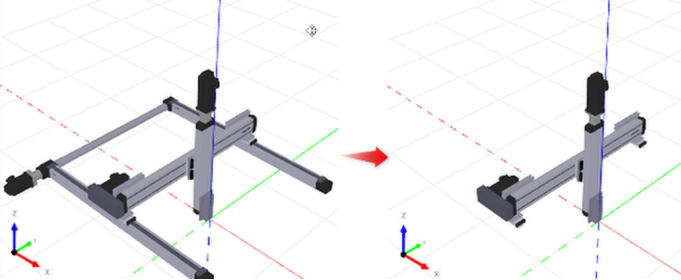

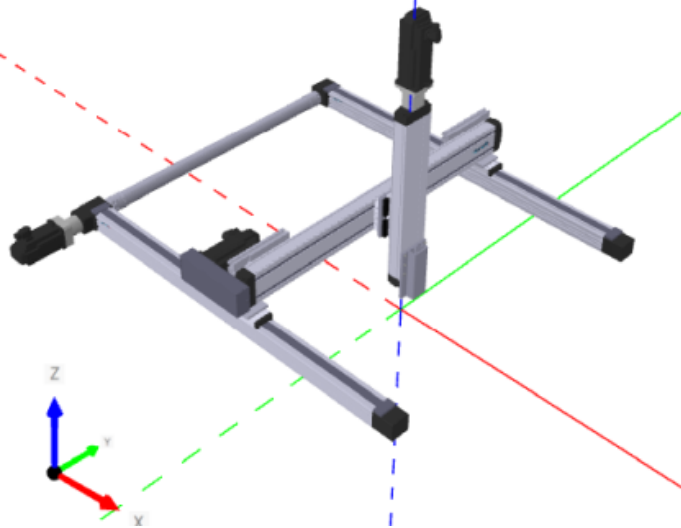

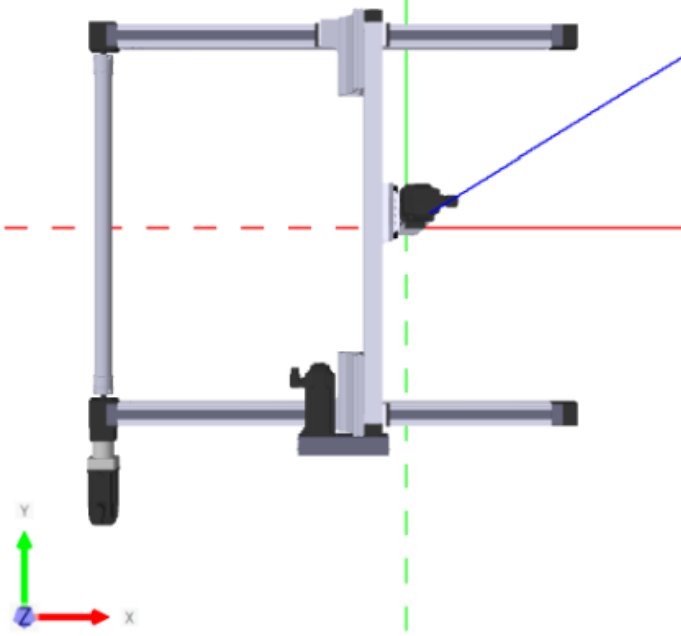



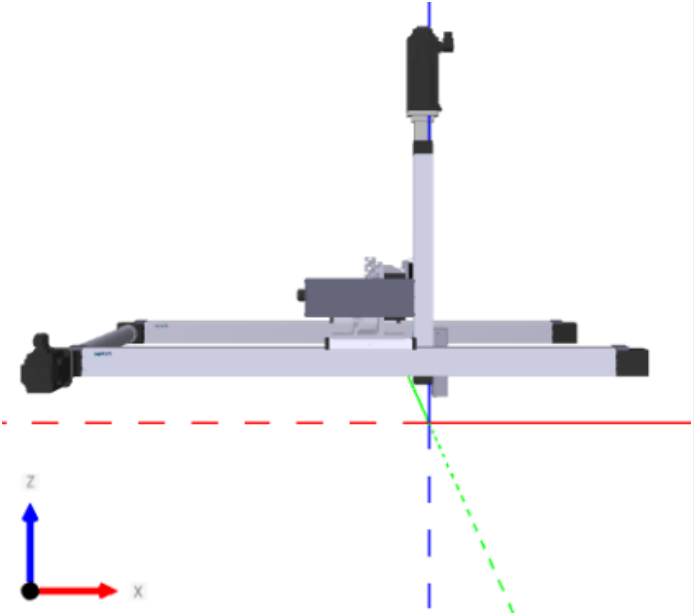

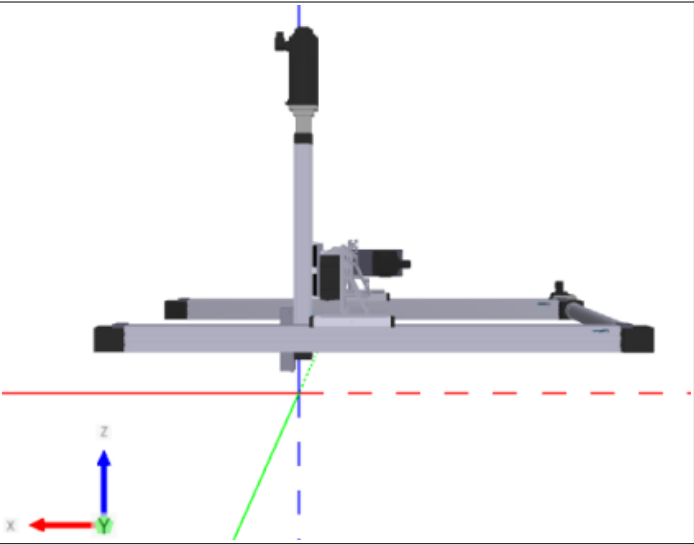

Fig. 15: Menu

Different views and settings can be selected.



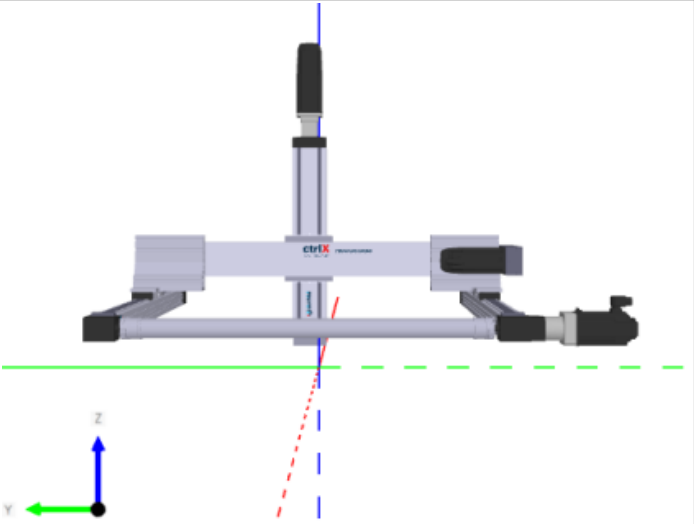

The respective menu buttons are explained in the following table.

Button	Function	
	<p>“Grid”</p> <p>A grid can be put under the graphics or hidden.</p>	
	<p>“Perspective”</p> <p>It can be toggled between the perspective view and the orthogonal projection.</p>	
	<p>“Coordinate”</p> <p>The coordinate axes can be made visible or hidden.</p>	

Button	Function	
	<p>“Hides housing”</p> <p>While enabling, only the child machine elements of the axes properly connected to the ctrlX Data Layer are visible.</p> <p>Rigid elements such as the base or the housing are not visible.</p>	
	<p>“ISO view”</p> <p>For the ISO view, the camera position set ensures that the three spatial axes in the project have an angle of 120° to one another. This is a standard view.</p> <p>After rotating the view, double-click on the model to return to the ISO view.</p>	
	<p>“Top view”</p> <p>The top view of the model is shown.</p>	

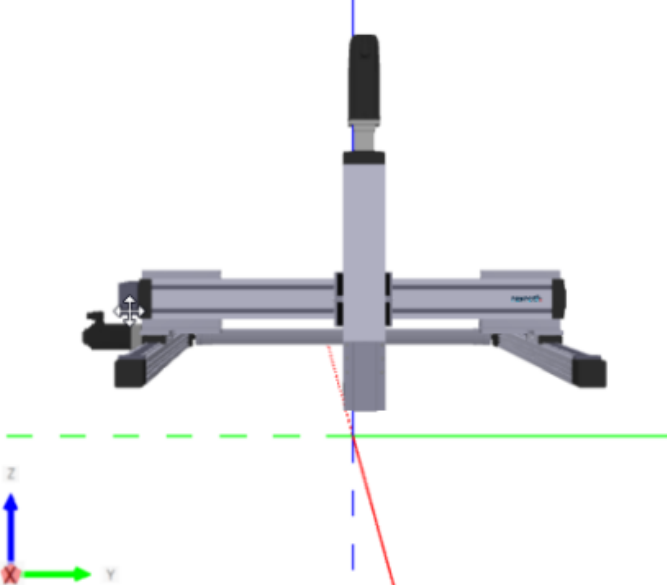
Button	Function	
	<p>“Front view” The front view of the model is shown.</p>	
	<p>“Back view” The back view of the model is shown.</p>	
	<p>“Left view” The left view of the model is shown.</p>	

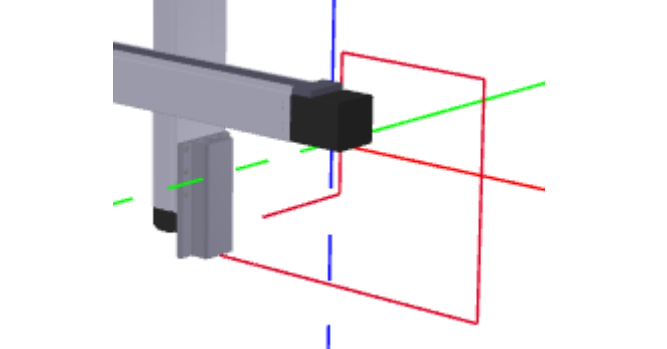
Menu “My Model”

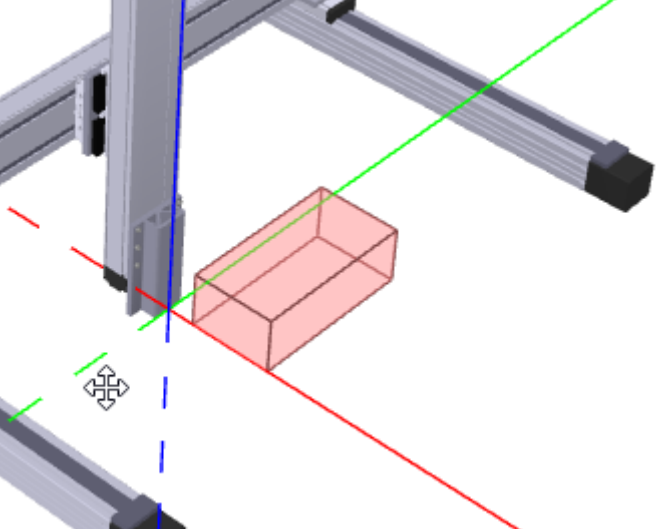
Button	Function	
	<p>“Right view” The right view of the model is shown.</p>	
	<p>“Toolpath” The path of the ToolNode resulting from the axis motion is displayed or deleted. This function is only available if a ToolNode is defined in the model.</p>	
	<p>“Working areas/Safe zones” Safe zones and working areas are shown. This function is only available in the “Connected” mode and if areas (currently only in MCS) are active.</p>	

Use the mouse to change the camera position:

- Left-click and drag:
The model rotates at the cursor position
- Right-click and drag:
The model moves along the cursor position
- Double-click:
The model is reset to the standard view. The graphics is assigned to the window size.

- Mouse wheel up:
The model is zoomed in.
- Mouse wheel down:
The model is zoomed out.

8.6 Mode "Full screen"

Call:

ctrlX CORE side navigation "*3D Viewer* → *My Model* → *Tab bar*" 

The full screen is enabled via the  button, but only the model and the setting bar become visible.

The focus is on the model.

To return to the normal view, click on the  button in the command bar or press the Esc key.

9 Related documentation

9.1 Overview

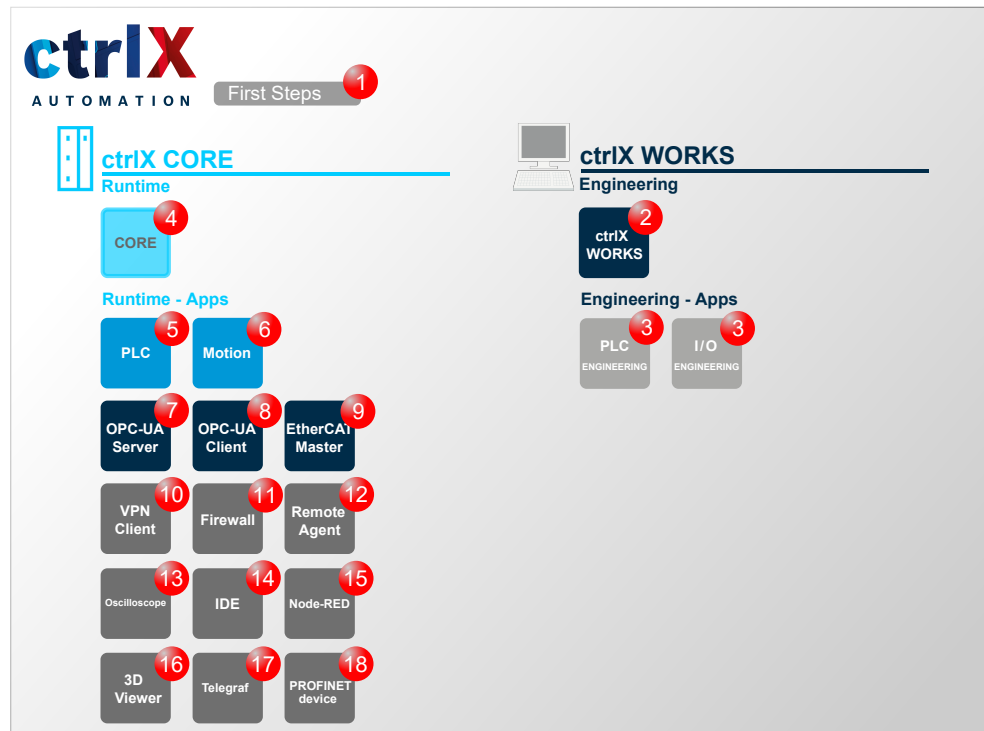

Fig. 16: Overview on further documentations

9.2 ctrlX AUTOMATION

No.	Documentation
1	<p>ctrlX WORKS First Steps Quick Start Guide ↪ Web documentation link Ordering information:</p> <ul style="list-style-type: none"> • DOK-XWORKS-F*STEP*****-QRS-EN-P • R911403760

9.3 ctrlX WORKS

No.	Documentation
2	ctrlX WORKS Basic System Application Manual ↔ Web documentation link Ordering information: <ul style="list-style-type: none"> • DOK-XWORKS-*****-APRS-EN-P • R911403761
3	ctrlX PLC Engineering - PLC Programming System Application Manual ↔ Web documentation link Ordering information: <ul style="list-style-type: none"> • DOK-XPLC**-ENGINEERING-APRS-EN-P • R911403764
3	ctrlX PLC Engineering - PLC Libraries Reference ↔ Web documentation link Ordering information: <ul style="list-style-type: none"> • DOK-XPLC**-LIBRARY****-RERS-EN-P • R911403766

9.4 ctrlX CORE

No.	Documentation
4	ctrlX CORE - Runtime Application Manual ↔ Web documentation link Ordering information: <ul style="list-style-type: none"> • DOK-XCORE*-BASE*****-APRS-EN-P • R911403768
	ctrlX CORE - Diagnostics Reference ↔ Web documentation link Ordering information: <ul style="list-style-type: none"> • DOK-XCORE*-DIAG*****-RERS-EN-P • R911403770

9.5 ctrlX CORE apps

No.	Documentation
5	PLC App - PLC Runtime Environment for ctrlX CORE Application Manual ↔ Web documentation link Ordering information: <ul style="list-style-type: none"> • DOK-XCORE*-PLC*****-APRS-EN-P • R911403787

No.	Documentation
6	Motion App - Motion Runtime Environment for ctrlX CORE Application Manual ↗ Web documentation link Ordering information: <ul style="list-style-type: none">• DOK-XCORE*-MOTION*****-APRS-EN-P• R911403791
7	OPC UA Server App - OPC UA Server for ctrlX CORE Application Manual ↗ Web documentation link Ordering information: <ul style="list-style-type: none">• DOK-XCORE*-OPCUA*SERV*-APRS-EN-P• R911403778
8	OPC UA Client App - OPC UA Client for ctrlX CORE Application Manual ↗ Web documentation link Ordering information: <ul style="list-style-type: none">• DOK-XCORE*-OPCUA*CLIEN-APRS-EN-P• R911403781
9	EtherCAT Master App - EtherCAT master for ctrlX CORE Application Manual ↗ Web documentation link Ordering information: <ul style="list-style-type: none">• DOK-XCORE*-ETHERCAT***-APRS-EN-P• R911403773
10	VPN Client App - Remote Support Software for ctrlX CORE Application Manual ↗ Web documentation link Ordering information: <ul style="list-style-type: none">• DOK-XCORE*-VPN*****-APRS-EN-P• R911403775
11	Firewall App - Security Functions for ctrlX CORE Application Manual ↗ Web documentation link Ordering information: <ul style="list-style-type: none">• DOK-XCORE*-FIREWALL***-APRS-EN-P• R911403783
12	Remote Agent App - ctrlX Device Portal Connection for ctrlX Devices Application Manual ↗ Web documentation link Ordering information: <ul style="list-style-type: none">• DOK-XCORE*-REMOTE*AG**-APRS-EN-P• R911403785

No.	Documentation
13	<p>Oscilloscope App - Oscilloscope Function for ctrlX Devices</p> <p>Application Manual</p> <p>↔ Web documentation link</p> <p>Ordering information:</p> <ul style="list-style-type: none"> ● DOK-XCORE*-OSCI*****-APRS-DE-P ● R911409806
14	<p>IDE App - Integrated Development Environment</p> <p>Application Manual</p> <p>↔ Web documentation link</p> <p>Ordering information:</p> <ul style="list-style-type: none"> ● DOK-XCORE*-IDE*****-APRS-DE-P ● R911410625
15	<p>Node RED App - Graphic Programming for ctrlX CORE</p> <p>Application Manual</p> <p>↔ Web documentation link</p> <p>Ordering information:</p> <ul style="list-style-type: none"> ● DOK-XCORE*-NODE*RED***-APRS-EN-P ● R911403789
16	<p>3D Viewer App - Browser-based 3D Kinematic Simulation for ctrlX CORE</p> <p>Application Manual</p> <p>↔ Web documentation link</p> <p>Ordering information:</p> <ul style="list-style-type: none"> ● DOK-XCORE*-3D*VIEWER**-APRS-EN-P ● R911416124
17	<p>Telegraf App - Server Agent for Collecting Data in the Data Layer</p> <p>Application Manual</p> <p>↔ Web documentation link</p> <p>Ordering information:</p> <ul style="list-style-type: none"> ● DOK-XCORE*-TELEGRAF***-AP01-EN-P ● R911416836
18	<p>PROFINET device App - PROFINET device for ctrlX CORE</p> <p>Application Manual</p> <p>↔ Web documentation link</p> <p>Bestellinformationen:</p> <ul style="list-style-type: none"> ● DOK-XCORE*-PROFINET***-AP01-EN-P ● R911417857

10 Service and support

Our worldwide service network provides an optimized and efficient support. Our experts provide you with advice and assistance. You can contact us **24/7**.

Service Germany

Our technology-oriented Competence Center in Lohr, Germany, is responsible for all your service-related queries for electric drive and controls.

Contact the **Service Hotline** and **Service Helpdesk** under:

Phone: **+49 9352 40 5060**

Fax: **+49 9352 18 4941**

Email: [↗ service.svc@boschrexroth.de](mailto:service.svc@boschrexroth.de)

Internet: [↗ http://www.boschrexroth.com](http://www.boschrexroth.com)

Additional information on service, repair (e.g. delivery addresses) and training can be found on our internet sites.

Service worldwide

Outside Germany, please contact your local service office first. For hotline numbers, refer to the sales office addresses on the internet.

Preparing information

To be able to help you more quickly and efficiently, please have the following information ready:

- Detailed description of malfunction and circumstances
- Type plate specifications of the affected products, in particular type codes and serial numbers
- Your contact data (phone and fax number as well as your e-mail address)

11 Index

1, 2, 3 ...

3D Viewer

Delete model.	19
Introduction.	11
Open model.	18
Prerequisites.	13
Upload model.	17

C

Commands.	21
Connected.	23
ctrIX AUTOMATION	
Related documentation.	35

D

Deleting model.	19
Dialog	
Commands.	21
Settings.	26
Disconnected.	21

F

Full screen.	33
-------------------	----

H

Helpdesk.	39
Hotline.	39

I

Intended use

Areas of application.	7
Areas of use.	7
Introduction.	7

Introduction.	11
--------------------	----

M

Menu.	28
Model Library.	17
My Model.	21

Mode

Connected.	23
Disconnected.	21
Full screen.	33

Model Library.	17
---------------------	----

My Model.	21
----------------	----

O

Opening model.	18
---------------------	----

P

Prerequisites.	13
---------------------	----

S

Safety instructions.	9
Service hotline.	39
Settings.	26
Support.	39

U

Unintended use.	8
Consequences, disclaimer.	7
Uploading model.	17

Bosch Rexroth AG
Bgm.-Dr.-Nebel-Str. 2
97816 Lohr a.Main
Germany
Tel. +49 9352 18 0
Fax +49 9352 18 8400
www.boschrexroth.com/electrics



R911416124