

# Rexroth Frequency Converter

Fe Series

**Instruction Manual (Quick Start)** Edition 04  
R912004884



## Record of Revision

Edition	Release Date	Notes
DOK-RCON01-FE*****-IN02-EN-P	2013.11	First release
DOK-RCON01-FE*****-IN03-EN-P	2014.11	Added new functions
DOK-RCON01-FE*****-IN04-EN-P	2014.12	Firmware upgrade

## About this Documentation

This **Instruction Manual (Quick Start)** is derived from the **Instruction Manual** which includes the product data in details.

Never work with or control the product before reading through the **Safety Instructions** in the standard delivery and the safety related chapters in the **Instruction Manual**.

## Reference

For documentations available in other type or language, please consult your local sales partner or check [www.boschrexroth.com/fe](http://www.boschrexroth.com/fe).

## Copyright

© Bosch Rexroth (Xi'an) Electric Drives and Controls Co., Ltd. 2014

This document, as well as the data, specifications and other information set forth in it, are the exclusive property of Bosch Rexroth (Xi'an) Electric Drives and Controls Co., Ltd. It may not be reproduced or given to third parties without its consent.

## Liability

The specified data is intended for product description purposes only and shall not be deemed to be a guaranteed characteristic unless expressly stipulated in the contract. All rights are reserved with respect to the content of this documentation and the availability of the product.

# Table of Contents

	Page
<b>1 Mechanical Installation.....</b>	<b>1</b>
1.1 Visual Check.....	1
1.2 Ambient Conditions.....	1
1.3 Installation Conditions.....	2
1.4 Dimensions.....	3
<b>2 Electric Installation.....</b>	<b>6</b>
2.1 Cable Specifications.....	6
2.2 Power Terminals.....	10
2.3 Interface Connection for Signals.....	12
<b>3 Parameter Settings.....</b>	<b>17</b>
3.1 Operating Panel.....	17
3.2 Start-up.....	18
3.3 Operating Descriptions.....	19
3.4 Parameters.....	20
<b>4 Error Indication.....</b>	<b>26</b>



# 1 Mechanical Installation

## 1.1 Visual Check

After unpacking the frequency converter, perform a thorough visual check. Check the following:

- **Has the right device been supplied?**
- **Is the device damaged?**
- **Check the case for transport damage such as scratches, cracks or dents.**

If you find a deviation from one of the above points, please contact your **Bosch Rexroth** sales partner.

## 1.2 Ambient Conditions

If it is to function perfectly, the frequency converter must be installed in an environment matching the data provided below.

<b>Ambient temperature</b>	-10...+40 °C (No derating)
	+40...+50 °C (Derating <sup>①</sup> )
<b>Max. altitude</b>	Up to 1,000 m (No derating)
	1,000...4,000 m (1 % / 100 m)
<b>Relative humidity</b>	< 90 %
<b>Degrees of protection</b>	IP 20 (Control cabinet mounting)

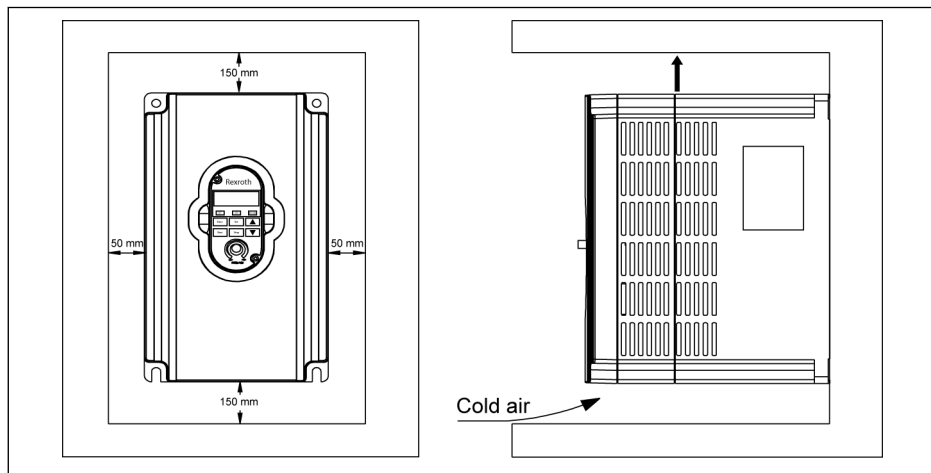
**Tab. 1-1:** Ambient conditions



<sup>①</sup>: See "9.2: Derating of Electrical Data" in the **Instruction Manual**.

## 1.3 Installation Conditions

Depending on rating, the frequency converters are available in different sizes. In order not to affect device cooling, the frequency converter must always be installed upright. For perfect heat dissipation, the minimum installation spacing to the devices shown in the drawing must be observed.



**Fig. 1-1:** Installation conditions



- The frequency converter shown above is Frame 1. The minimum installation spacing stated applies to Frame 1 to Frame 7.
- The frequency converter must be vertically installed.
- If one frequency converter is arranged above another, make sure the upper limit of air temperature into the inlet is not exceeded (see [chapter 1.2 "Ambient Conditions" on page 1](#)). A baffle plate is recommended between the frequency converters to prevent the rising hot air being drawn into the upper frequency converter if the upper limit of air temperature is exceeded.

## 1.4 Dimensions

Fe model	Frame	Width	Height	Depth	Mounting hole	Net weight
		B/b	H/h	T	Ø G	m
		[mm]	[mm]	[mm]	[mm]	[kg]
FECG02.1-0K75-...	1	125/109	220/204	176	6	3
FECG02.1-1K50-...						3.2
FECG02.1-2K20-...						
FECG02.1-4K00-...						
FECx02.1-5K50-...						
FECx02.1-7K50-...						
FECx02.1-11K0-...	2	220/180	392/372	218	9.5	10.7
FECx02.1-15K0-...						10.9
FECx02.1-18K5-...	3	275/200	463/443	218	9.5	16.2
FECx02.1-22K0-...						16.9
FECx02.1-30K0-...	4	290/200	574/550	236	11	21.5
FECx02.1-37K0-...						22
FECx02.1-45K0-...	5	364/260	602/576	260	11	33.2
FECx02.1-55K0-...						33.8
FECx02.1-75K0-...	6	455/375	682/650	290	11	50.9
FECx02.1-90K0-...						52.5
FECx02.1-110K-...	7	570/450	850/825	360	11	96.5
FECx02.1-132K-...						100
FECx02.1-160K-...						102

**Tab. 1-2:** Fe dimensions



"x" in Fe model "FECx..." is a substitute for G or P series.

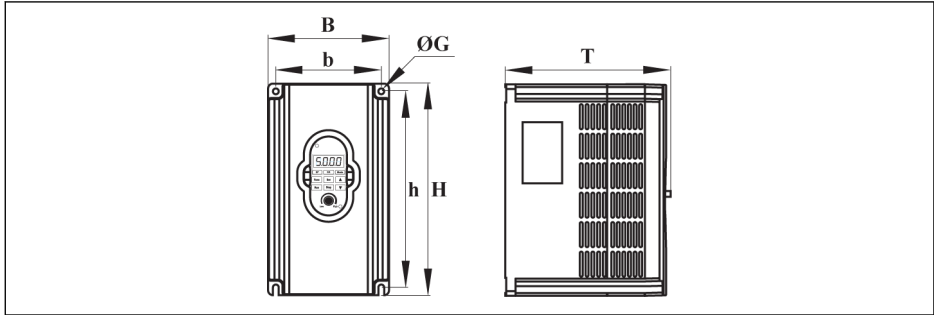


Fig. 1-2: Frame 1

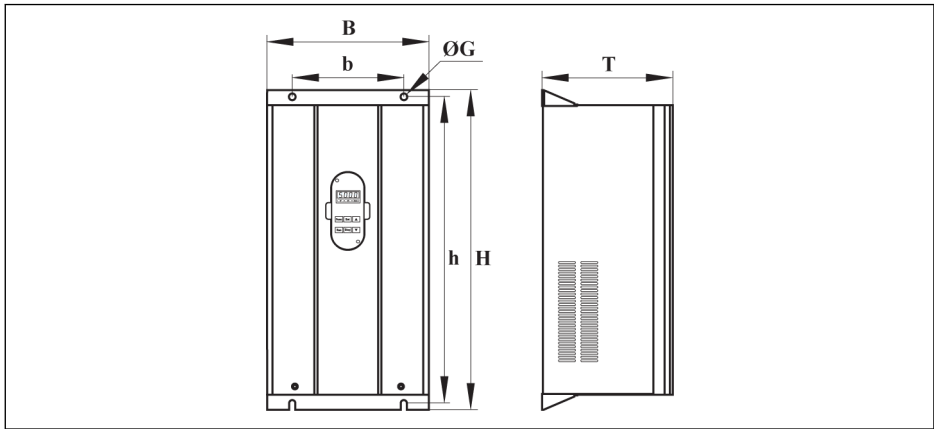


Fig. 1-3: Frame 2, 3, 4

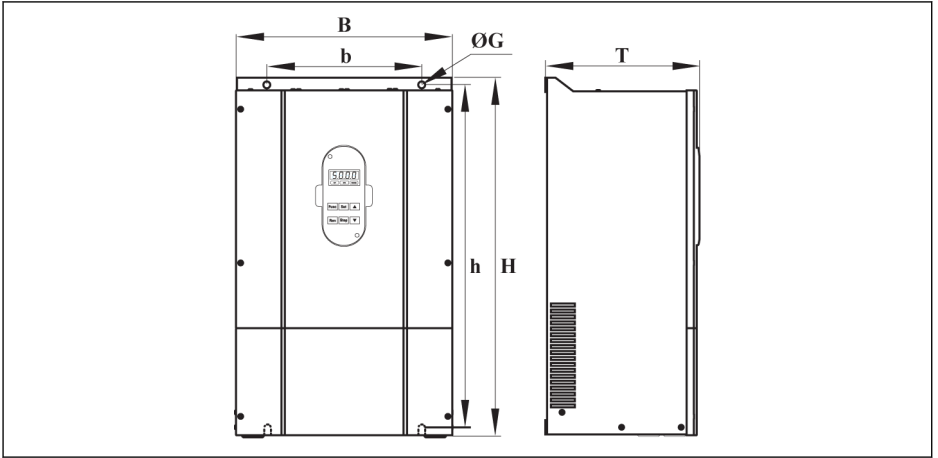


Fig. 1-4: Frame 5, 6

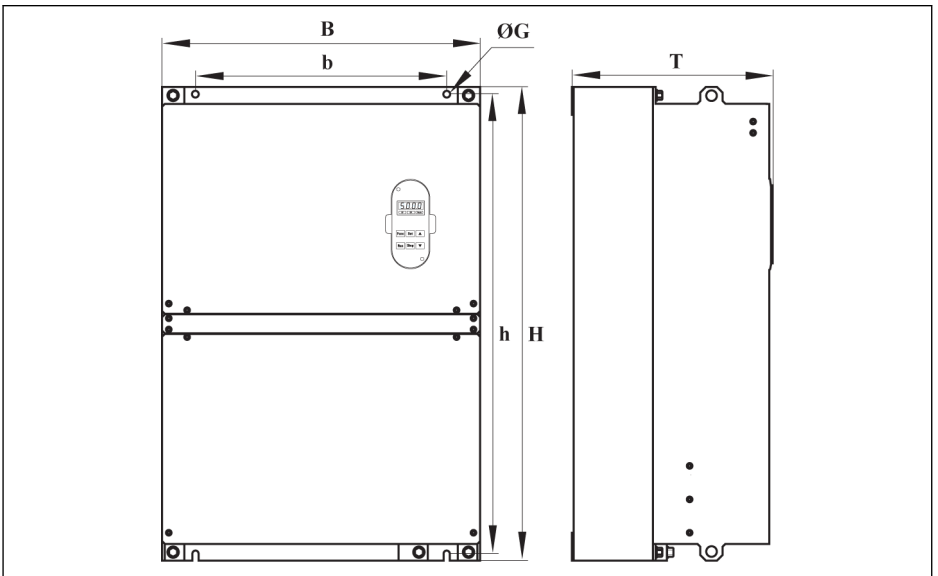


Fig. 1-5: Frame 7

## 2 Electric Installation

### 2.1 Cable Specifications

#### 2.1.1 Connecting to the Mains

##### Cable specification for international without USA / Canada



- **ONLY USE** copper wires of 90 °C or above with XLPE or EPR insulation according to IEC 60364-5-52.
- It is recommended to use shielded cables to connect the motor.
- The specification is based on the supply voltage of 3P 380 VAC.

Fe Model	Fuse	Power cables installation mode				PE	
		B1	B2	E	Torque / Screw	Cable size	Torque /Screw
	[A]	[mm <sup>2</sup> ]	[mm <sup>2</sup> ]	[mm <sup>2</sup> ]	[Nm / lb-in] (Mx)	[mm <sup>2</sup> ]	[Nm / lb-in] (Mx)
0K75	10	1.5	1.5	1.5	1.8 (M4)	10	1.8 (M4)
1K50	10	1.5	1.5	1.5	1.8 (M4))	10	1.8 (M4)
2K20	16	1.5	1.5	1.5	1.8 (M4)	10	1.8 (M4)
4K00	20	2.5	2.5	2.5	1.8 (M4)	10	1.8 (M4)
5K50	25	4	4	2.5	1.8 (M4)	10	1.8 (M4)
7K50	25	4	4	2.5	1.8 (M4)	10	1.8 (M4)
11K0	32	6	6	4	2...2.8 (M5)	10	2...2.8 (M5)
15K0	50	10	10	10	2...2.8 (M5)	10	2...2.8 (M5)
18K5	63	16	16	10	4...5 (M6)	16	4...5 (M6)
22K0	80	16	25	16	4...5 (M6)	16	4...5 (M6)
30K0	100	25	-	25	4...5 (M6)	16	4...5 (M6)
37K0	125	25	25	25	4...5 (M6)	16	6...9 (M8)
45K0	160	50	-	50	6...9 (M8)	25	6...9 (M8)
55K0	160	50	-	50	6...9 (M8)	25	15...20 (M10)
75K0	250	95/2*50	-	95/2*50	15...20 (M10)	50	15...20 (M10)
90K0	250	95/2*50	-	95/2*50	15...20 (M10)	50	15...20 (M10)
110K	315	-	-	150/2*70	15...20 (M10)	95	15...20 (M10)
132K	315	-	-	150/2*70	20 (M12)	120	15...20 (M10)
160K	400	-	-	240	20 (M12)	120	15...20 (M10)

Tab. 2-1: Fuse and cable dimensions for international without USA / Canada

## Cable specification for USA / Canada



- **ONLY USE** copper wires of 75 °C or above according to UL 508C.
- It is recommended to use shielded cables to connect the motor.
- The specification is based on the supply voltage of 3P 380 VAC.
- The cables connecting to PE terminal should assemble the UL certified wire connector which has suitable rating for wire gauge!

Fe Model	Fuse [A]	Power cables		PE	
		Cable size	Torque / Screw	Cable size	Torque / Screw
		[AWG]	[Nm / lb-in] (Mx)	[AWG]	[Nm / lb-in] (Mx)
0K75	6	14	1.8 (M4)	8	1.8 (M4)
1K50	10	14	1.8 (M4))	8	1.8 (M4)
2K20	15	14	1.8 (M4)	8	1.8 (M4)
4K00	25	10	1.8 (M4)	8	1.8 (M4)
5K50	30	10	1.8 (M4)	8	1.8 (M4)
7K50	40	10	1.8 (M4)	8	1.8 (M4)
11K0	50	6	2...2.8 (M5)	8	2...2.8 (M5)
15K0	60	6	2...2.8 (M5)	8	2...2.8 (M5)
18K5	80	4	4...5 (M6)	8	4...5 (M6)
22K0	80	4	4...5 (M6)	8	4...5 (M6)
30K0	100	3	4...5 (M6)	8	4...5 (M6)
37K0	125	3	4...5 (M6)	6	6...9 (M8)
45K0	150	2/0	6...9 (M8)	6	6...9 (M8)
55K0	175	2/0	6...9 (M8)	6	15...20 (M10)
75K0	225	4/0	15...20 (M10)	4	15...20 (M10)
90K0	250	4/0	15...20 (M10)	4	15...20 (M10)
110K	300	350 kcmil	15...20 (M10)	4	15...20 (M10)
132K	400	750 kcmil	20 (M12)	3	15...20 (M10)
160K	450	750 kcmil	20 (M12)	2	15...20 (M10)

**Tab. 2-2:** Fuse and cable dimensions for USA / Canada

## 2.1.2 Signal Connection

The following requirements apply for the signal connection wiring:

- flexible cables with wire end sleeves
- cable cross-section: 0.3...1.0 mm<sup>2</sup>
- cable length: max. 20 m
- analog inputs  $\pm 10$  V, VR1, VR2, +I and GND: use shielded cables
- analog inputs +I and GND: to eliminate interference from external influences, connect +I and GND on the transducer with a 22 nF capacitor (50 V) and run the signal cable two or three times through a ferrite ring.

### 2.1.3 Overview of Electric Connections

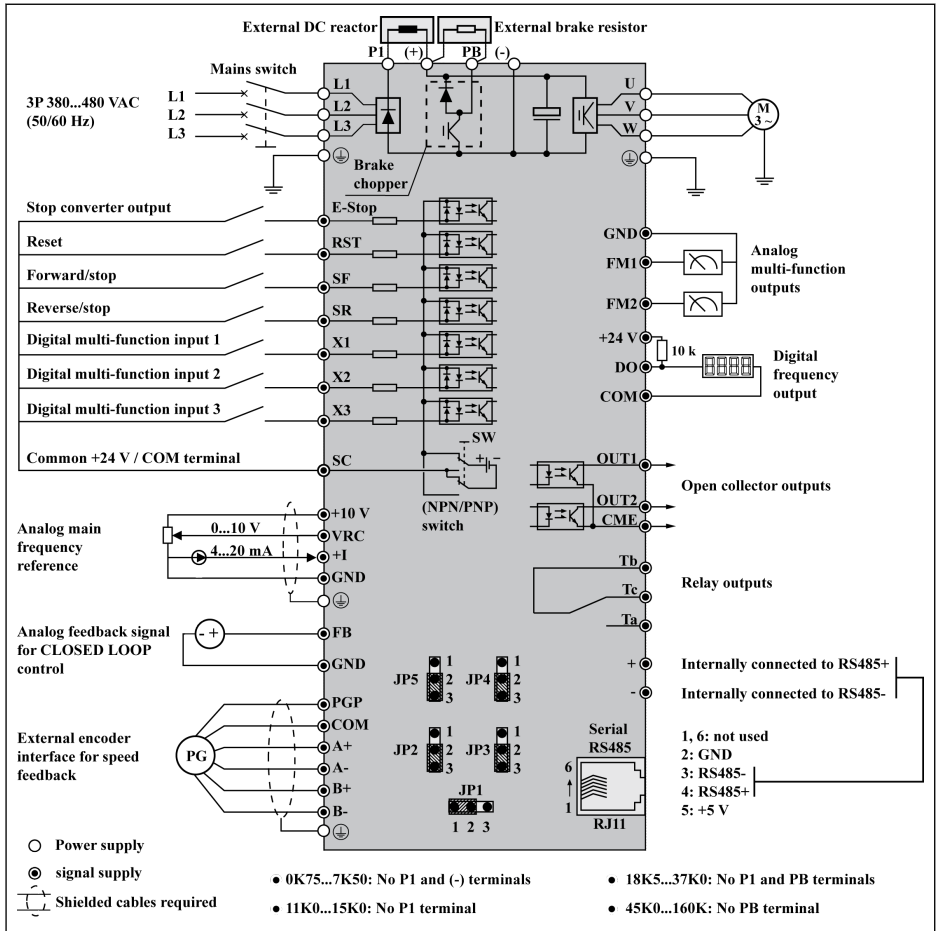


Fig. 2-1: Block diagram



Fe up to 15K0 have internal brake choppers.

## 2.2 Power Terminals

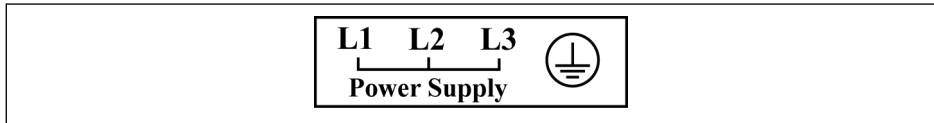
The table below describes the symbols on the frequency converter's power connection terminals and their function.

Terminal	Description
L1, L2, L3	Mains power supply inputs
U, V, W	Frequency converter outputs (to be connected to the motor)
PB	Reserved terminal for external brake resistor (applicable to 0K75...15K0 frequency converters)
P1, (+)	DC positive bus outputs
(-)	DC negative bus output
⊕	Grounding

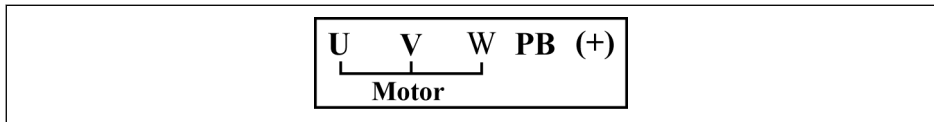
**Tab. 2-3:** Power terminals description

Depending on size, the position and sequence of the power terminals on the individual frequency converter may differ. Refer to the graphics below for the exact connection terminal position and sequence.

### Applicable to 0K75...7K50

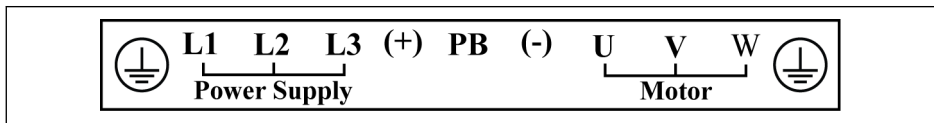


**Fig. 2-2:** Power terminals\_Frame 1\_Top



**Fig. 2-3:** Power terminals\_Frame 1\_Bottom

### Applicable to 11K0...15K0



**Fig. 2-4:** Power terminals\_Frame 2

### Applicable to 18K5...37K0

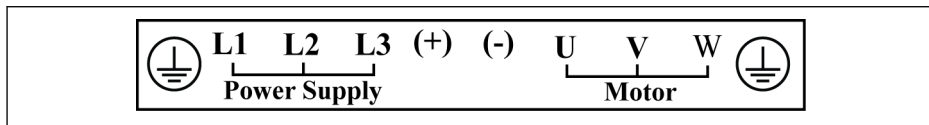


Fig. 2-5: Power terminals\_Frame 3, 4

### Applicable to 45K0...90K0

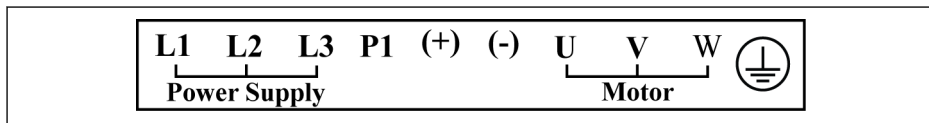


Fig. 2-6: Power terminals\_Frame 5, 6

### Applicable to 110K

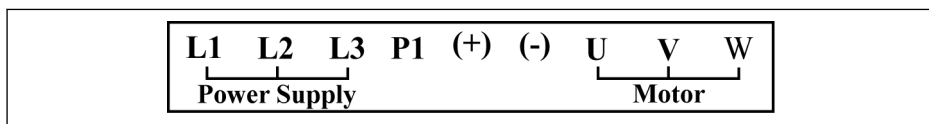


Fig. 2-7: Power terminals\_Frame 7 (110K)

### Applicable to 132K...160K

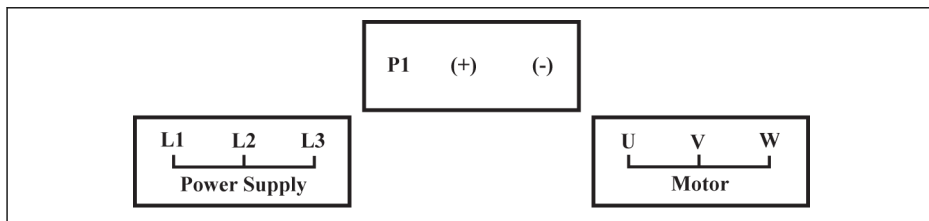


Fig. 2-8: Power terminals\_Frame 7 (132K, 160K)



1. For 11K0...160K, the main circuit terminals are on the bottom of the frequency converters.
2. For 45K0...160K, UL marked connectors and cables should be used for wiring of the terminal blocks. The connectors may be of crimp, ring or fork types or other similar types.
3. There are two grounding connections, one for the input side, the other for the output side.

## 2.3 Interface Connection for Signals

### 2.3.1 Jumper Wiring

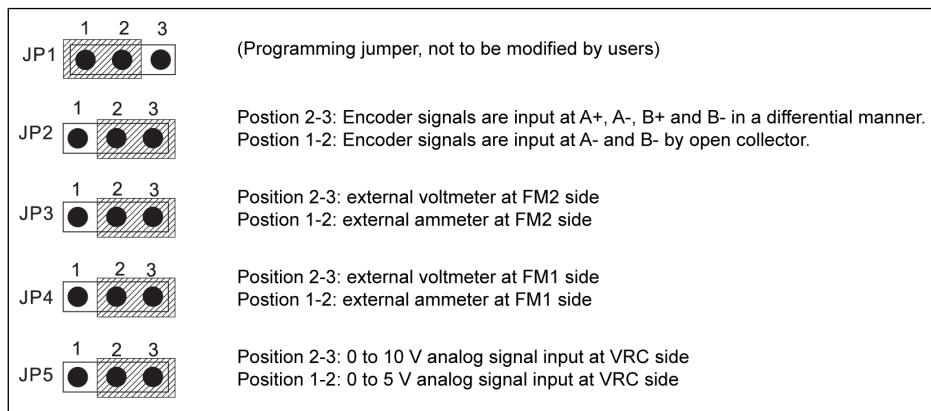


Fig. 2-9: Jumper description



Shown above are factory defaults.

### 2.3.2 Communication Port

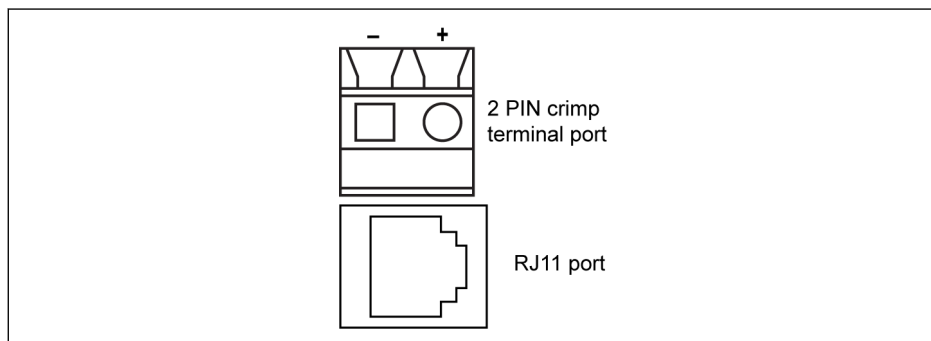


Fig. 2-10: RS485 communication port



- Crimp terminal wiring range: AWG 22...AWG 12
- Crimp terminal wire type: 75 °C and above copper only
- Crimp terminal torque: 5 kgf-cm (4.3 In-ibf)

### 2.3.3 NPN/ PNP Mode Selection

#### Jumper SW

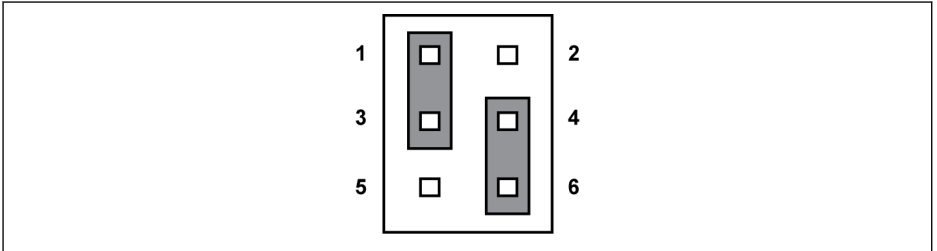


Fig. 2-11: NPN/PNP Jumper SW



As shown in the figure above, the factory default setting of the jumper is NPN.

#### Jumper SW determines:

1. The internal 24 V power supply or an external 24 V power supply.
2. The inputs are activated by connection of 24 V to an input (PNP/ active input) or connection of 0 V to an input (NPN/ passive input).

### 2.3.4 Analog Input Terminal (+10 V, VRC, GND, +I)

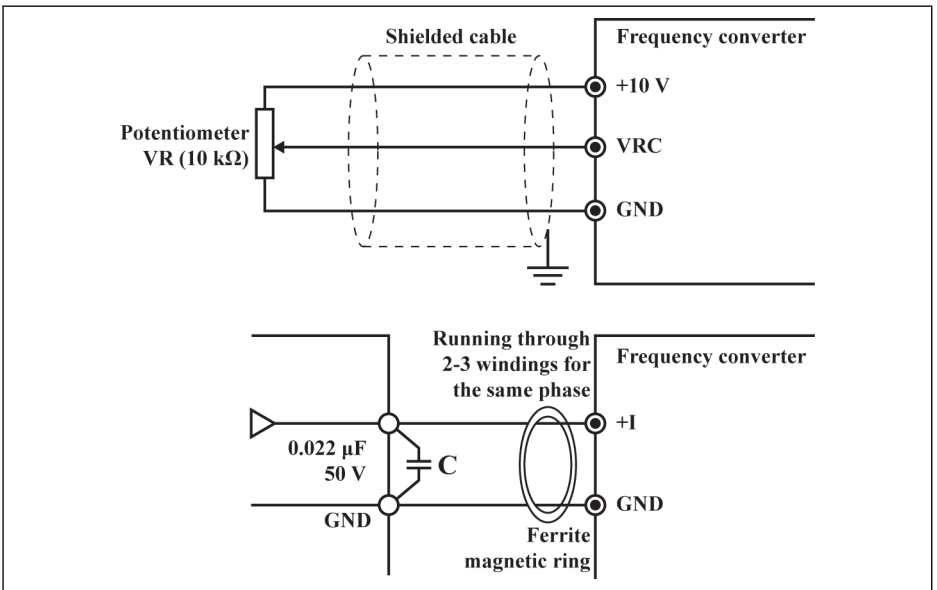


Fig. 2-12: Analog input terminal



1. For connection of low level analog signals, which are easily affected by external interference, the wiring length should be as short as possible (less than 20 m), shielded cables must be used.
2. Incorrect operation may occur due to interference on the analog signal. In such cases, connect a capacitor and ferrite core at the output side of the analog signal, as shown above.

## 2.3.5 Control Circuit Terminals

### Control circuit terminals figure

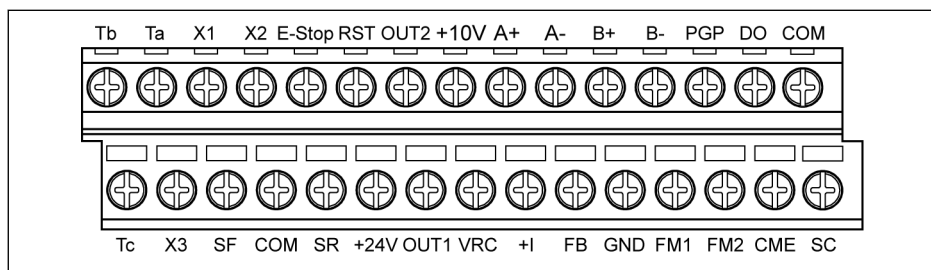


Fig. 2-13: Control circuit terminals



Applicable to 0K75...160K CPU board.

### Control circuit terminals description

Terminal	Signal function	Description	Signal requirement
SF	Forward/stop	See parameters b00 and E38	Opto-electronic coupler isolated input, 24 VDC for external power supply  NPN/PNP modes, see <a href="#">fig. 2-11 "NPN/PNP Jumper SW"</a> on page 13 for details
SR	Reverse/stop	See parameters b00 and E38	
RST	Error reset	"Connected" for reset	
E-Stop	External abnormality input	[E32] = 0: "Connected", coasting to stop [E32] = 1, "Disconnected", coasting to stop	
X1	Multi-function inputs	See parameters b00, b34, b35, b45, E39, H07 and H23	
X2			
X3			
SC	Shared connection for digital signals	Shared connection for SF\SR\RST\E-Stop\X1...X3	

Tab. 2-4: Digital inputs

Terminal	Signal function	Description	Signal requirement
FB	Feedback input signal	Feedback signal, analog voltage input	Input voltage range: 0...5 V Input resistance: 100 k $\Omega$ Resolution: 1:1000
+10V	Power supply terminal for speed commands	Power supply for speed commands	10 V (max. current 10 mA)
VRC	Frequency commands	Analog voltage frequency command	JP5, position 2-3 Input voltage range: 0...10 V Input resistance: 100 k $\Omega$ Resolution: 1:2000 JP5, position 1-2 Input voltage range: 0...5 V Input resistance: 50 k $\Omega$ Resolution: 1:2000
+I		Analog current frequency feedback signal	Input current range: 4...20 mA Input resistance: 165 $\Omega$ Resolution: 1:1000
GND	Analog common terminal	Isolated from COM	-

**Tab. 2-5:** Analog inputs

Terminal	Signal function	Description	Signal requirement
OUT1	Open collector output 1	Programmable digital output with multiple functions. See parameters E16, E17 for details	Open collector outputs isolated via opto-electronic couplers: Max. output voltage: +24 VDC Max. output current: 50 mA
OUT2	Open collector output 2		
CME	Common terminal for OUT1 and OUT2	For internal 24 V power supply: to be short circuited to the COM terminal For external power supply: to be short circuited to the "earth" of the power supply.	
DO-COM	Pulse output	Programmable to be pulse output with multiple functions. See parameters E09 for details.	Open collector outputs isolated via opto-electronic couplers: Output frequency: depends on E10, max. 50.0 kHz Max. output voltage: 24 VDC

Terminal	Signal function	Description	Signal requirement
Ta	Relay Ry output	Ta-Tb: N.O.; Tb-Tc: N.C. (Tb is the common terminal)	Contact transmitter capacity: 250 VAC, 3 A or lower 30 VDC, 3 A or lower
Tc			
Tb	Relay output common terminal	Programmable relay output with multiple functions. See parameter E18	
+24 V	Anode 24 VDC	COM (Cathode)	-

**Tab. 2-6:** Digital outputs

Terminal	Signal function	Description	Signal requirement
FM1-GND	Analog multi- function output 1	Programmable analog output with multiple functions. See parameters E04...E08 for details.	Output voltage/current settable via JP3, JP4 for FM1, FM2:
FM2-GND	Analog multi- function output 2		Voltage signal range: 0/2...10 V Current signal range: 0/4...20 mA

**Tab. 2-7:** Analog outputs

Terminal	Signal function	Description	Signal requirement
PGP-COM	Supply voltage nonbreak function	Power supply for the encoder	Max. output current: 100 mA
A+	Encoder signal A	JP2, position 2-3: select encoder differential inputs from A+, A-, B+ and B-	Encoder voltage range for differential input: +8...24 V
A-			
B+	Encoder signal B	JP2, position 1-2: select open collector inputs from A-, B-	Max. input frequency: 200.0 kHz
B-			

**Tab. 2-8:** Encoder signal

Terminal	Signal function	Description	Signal requirement
485+	Positive terminal for differential signal RS485	Standard 485 communication port. Use twisted pair or shielded cables. RJ11 port and 2 PIN crimp terminals are optional. Both connections are connected internally with the same 485 port (parallel mode).	
485-	Negative terminal for differential signal RS485		

**Tab. 2-9:** Communication

## 3 Parameter Settings

### 3.1 Operating Panel

The operating panel is at the center of the frequency converter and composed of two areas: display and keys. The display shows mode settings and state of the frequency converter. The keys allow the user to program the frequency converter.

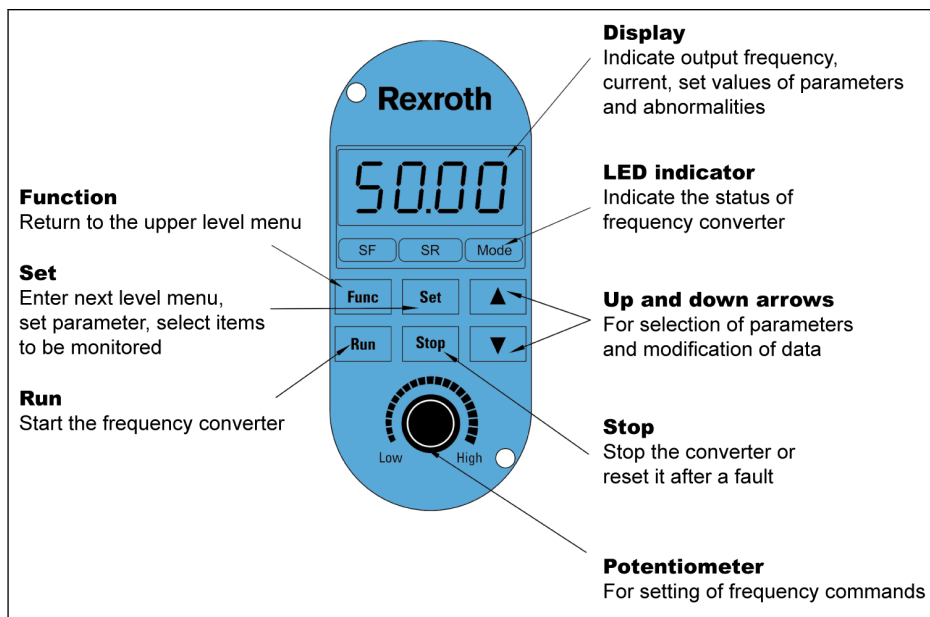


Fig. 3-1: Fe operating panel



For frequency converters of 0K75...7K50, the potentiometer is configured as standard, while for frequency converters of 11K0...160K, no potentiometer is configured as standard.

### 3.2 Start-up

The diagram below shows the standard start-up procedure for the frequency converter.

- White boxes: check whether all the work listed has been performed correctly before beginning the start-up
- Light grey boxes: start-up (described on the following pages)
- Dark grey boxes: to prevent damage, proceed as is described after the start-up

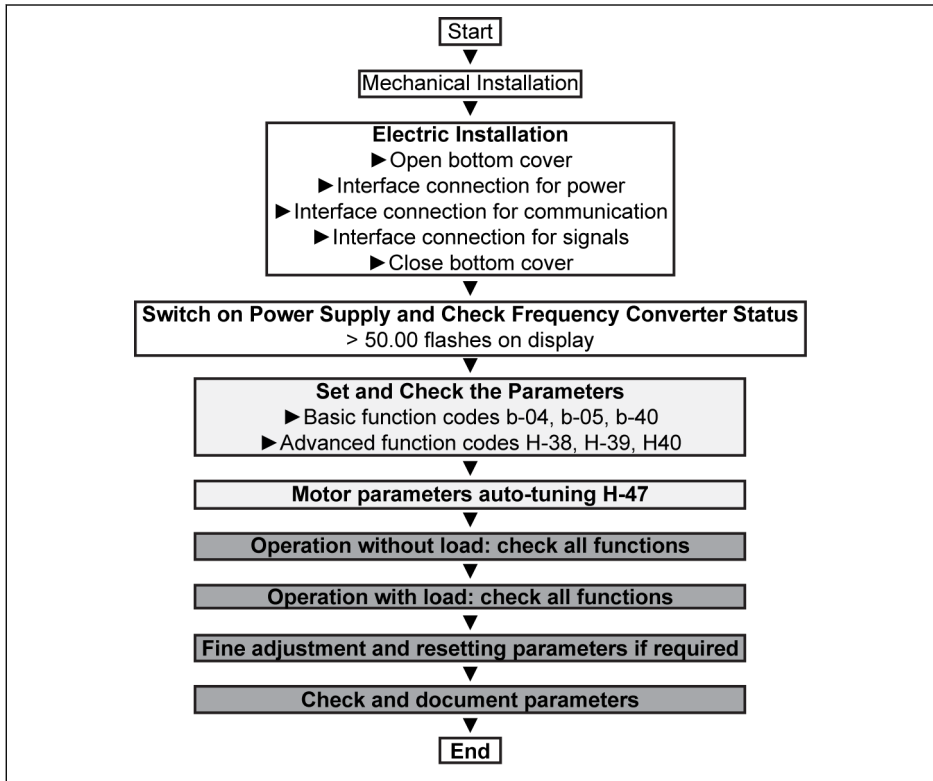


Fig. 3-2: Start-up procedure

### 3.3 Operating Descriptions

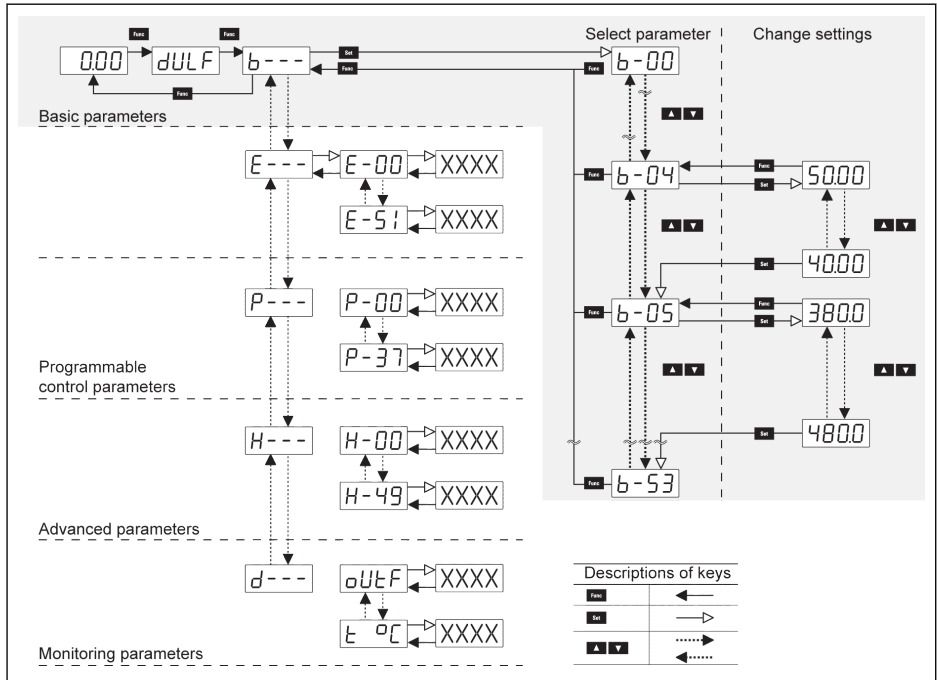


Fig. 3-3: Navigation and parameter settings

## 3.4 Parameters

### 3.4.1 Description of Attribute Symbols in Parameter Tables

Parameter attribute	Description
	Parameter setting can be modified when the frequency converter is in run mode
●	Parameter setting cannot be modified when the frequency converter is in run mode
★	Parameter setting cannot be modified directly

Tab. 3-1: Parameter attributes and descriptions



- Code: means function / parameter code, written in bxx, Exx, Pxx and Hxx.
- Value of function / parameter code: written in [bxx], [Exx], [Pxx] and [Hxx].
- Default: values that correspond to the factory default upon initialization at 50 Hz.
- Attrib.: means attribute.

### 3.4.2 Quick Start Parameters

#### Access & motor nameplate parameters

Code	Name	Setting range	Default	At-trib.
H39	Rated motor power	0.4...999.9 kW	Depends on model	●
H40	Rated motor current	0.1...999.9 A		●

#### Start-up parameters

Code	Name	Setting range	Default	At-trib.
b00	Set the source of control commands (option 1 and 3 have frequency command source)	0...7	0	●
b02	Set the source of frequency commands (5 types of sources)	0...12	1	●
b03	Highest frequency – HF	50.00...599.00 Hz	50.00	●
b04	Base frequency – BF	20.00 Hz...HF	50.00	●
b05	Base voltage – BV	400 V class: 240.0...480.0 V	380.0	●
b06	V/f curve mode	OFF; H-00...H-15; P-00...P-15	Depends on model	●
b16	Acceleration time	0.1...6,500.0 s		
b17	Deceleration time	0.1...6,500.0 s		
b32	Starting frequency	0.00...60.00 Hz	0.50	
b33	Starting holding time	0.0...10.0 s	0.0	

#### b00 setting range:

0: Run/Stop control with digital operating panel

1: External via control terminals, **Up/Down** control

2: External via control terminals (including multi-speed), while **<Stop>** key is activated

3: Logic control

4: External via control terminals (X3 is used to switch between internal/external sources of frequency command, while **Stop** key is activated)

5: External computer controls **Run/Stop**, while **<Stop>** key is activated

6: External computer controls **Run/Stop**, while **<Stop>** key is deactivated

7: External via control terminals (X1, X2 and X3 are used to switch between sources of frequency command, while **<Stop>** key is activated)

#### b02 setting range:

0: Set via the digital operating panel

1: Direct action of the digital operating panel's potentiometer  $K_v \times (0...5 \text{ V})$

2: Inverse action of the digital operating panel's potentiometer  $K_v \times (5...0 \text{ V})$

3: Direct action of external terminal  $K_v \times (0...5 \text{ V})$

4: Inverse action of external terminal  $K_v \times (5...0 \text{ V})$

5: Direct action of external terminal  $K_v \times (0...10 \text{ V})$

6: Inverse action of external terminal  $K_v \times (10...0 \text{ V})$

7: Direct action of external terminal  $K_i \times (4...20 \text{ mA})$

8: Inverse action of external terminal  $K_i \times (20...4 \text{ mA})$

9: External terminal  $K_v \times (0...5 \text{ V}) + K_i \times (4...20 \text{ mA})$  or External terminal  $K_v \times (0...10 \text{ V}) + K_i \times (4...20 \text{ mA})$

10: VRC terminal  $K_v \times (-10...+10 \text{ V})$

11:  $K_p \times (\text{Pulse frequency setting}) + K_v \times (\text{VRC} - 5 \text{ V})$  or  $K_p \times (\text{Pulse frequency setting}) + K_v \times (\text{VRC} - 2.5 \text{ V})$

12: External computer frequency setting

**b06 setting range:**

OFF: User-defined V/f curve

H-00...H-15: Constant torque characteristic

P-00...P-15: Square descending torque characteristic

## Input / Output terminal functions

Code	Name	Setting range	Default	Attrib.
b34	Stopping mode selection	0: OFF; 1: X1; 2: X2; 3: X3; 4: on	0	●
b35	Jogging mode selection	0: OFF; 1: X1; 2: X2; 3: X3	0	●
b45	Switching between local and remote control	0: OFF; 1: X1; 2: X2; 3: X3	0	●
E39	Self-holding function	0: OFF; 1: X1; 2: X2; 3: X3	0	●
H07	DC braking holding options	0: OFF; 1: X1; 2: X2; 3: X3; 4: ON	0	
H23	Energy saving mode	0: Disabled; 1: X1; 2: X2; 3: X3; 4: Automatic energy saving	0	●
H28	Process PI deactivation	0: OFF; 1: X1; 2: X2; 3: X3	0	●
E04	FM1 selection	0...4	0	
E05	FM1 gain setting	0.50...9.99	1.00	
E06	FM2 selection	0...4	1	
E07	FM2 gain setting	0.50...9.99	1.00	
E08	FM channel mode	0...3	0	
E09	Pulse output selection	0...3	2	
E10	Maximum output pulse frequency	0.1...50.0 kHz	10.0 kHz	
E11	Frequency level detection FDT1	0.00...599.00 Hz	50.00 Hz	
E12	FDT1 lagging frequency	0.00...599.00 Hz	1.00 Hz	
E13	Frequency level detection FDT2	0.00...599.00 Hz	25.00 Hz	
E14	FDT2 lagging frequency	0.00...599.00 Hz	1.00 Hz	
E15	Frequency arrival detection range	0.00...599.00 Hz	2.00 Hz	
E16	Open collector output OUT1	0...25	6	
E17	Open collector output OUT2		0	
E18	Relay Ry output selection		12	

### E04, E06 setting range :

- 0: Output frequency
- 1: Output voltage
- 2: Output current
- 3: PI feedback signal
- 4: Set frequency

### E08 setting range:

- 0: FM1 outputs 0...20 mA or 0...10 V, FM2 outputs 0...20 mA or 0...10 V

- 1: FM1 outputs 4...20 mA or 2...10 V, FM2 outputs 4...20 mA or 2...10 V
- 2: FM1 outputs 0...20 mA or 0...10 V, FM2 outputs 4...20 mA or 2...10 V
- 3: FM1 outputs 4...20 mA or 2...10 V, FM2 outputs 0...20 mA or 0...10 V

**E09 setting range :**

- 0: Output frequency
- 1: Output voltage
- 2: Output current
- 3: Set frequency

**E16...E18 setting range :**

- 0: Running
- 1: Frequency level detection signal 1 (FDT1)
- 2: Frequency level detection signal 2 (FDT2)
- 3: Frequency arrival signal (FAR)
- 4: Reserved
- 5: Under voltage
- 6: Overload (O.L.)
- 7: Reserved
- 8: Zero speed (lower than starting frequency)
- 9: E-Stop
- 10: Low voltage
- 11: No trip action
- 12: Error
- 13: Programmable program running
- 14: Programmable program run
- 15: Run for one stage
- 16: Over current stall
- 17: Over voltage stall
- 18: In forward rotation command indication
- 19: In reverse rotation command indication
- 20: Zero speed (incl. stop)
- 21: Being braked
- 22: Accelerating
- 23: Decelerating
- 24: Fan action
- 25: Reserved

## Error message and diagnosis

Code	Name	Setting range	Default	At-trib.
E45	Current error record	0...15	0	★
E46	Last error record			
E47	Last 2 error records			
E48	Last 3 error records			
b39	Data protection options and initialization	0...4	0	●

0: No error record

1: O.C.-1, over current at constant speed

2: O.C.-2, over current during acceleration

3: O.C.-3, over current during deceleration

4: O.E.-1, over voltage at constant speed

5: O.E.-2, over voltage during acceleration

6: O.E.-3, over voltage during deceleration

7: O.L., motor overload

8: O.H., frequency converter overheat

9: d.r., drive protection

10: CPU-, EMI

11: IPH.L., input phase loss

12: oPH.L., output phase loss

13: E.-St., stopping by external abnormality command

14: O.T., motor overheat

15: CPUE, EMI

### b39 setting range:

0: All parameters are readable and rewritable

1: All parameters are read-only except b01 and b39

2: Initialization to factory defaults at 50 Hz\*

3: Initialization to factory defaults at 60 Hz

4: Clear all error records



\*: Press and hold <▲> key for 2 seconds to change b39 from 1 to 2, 3 or 4.

## 4 Error Indication

The frequency converter can record the reasons of the last 4 errors and can display them after resetting from errors.

Error code	Error name	Possible reason	Solution
O.C.-1	Over current at constant speed	Excessively reduced acceleration/ deceleration time	Increase acceleration/ deceleration time
		Load short circuit or sudden changes in load	Check the load
		Low grid voltage	Check input power supply
		A special motor or a motor larger than the maximum allowable capacity	Use a frequency converter with suitable power
O.C.-2	Over current during acceleration	Too short acceleration time	Increase acceleration time
		Improper V/f curve	Enable automatic torque increasing or manually adjust V/f curve settings
		The frequency converter power is too low	Select a frequency converter with higher power
O.C.-3	Over current during deceleration	Too short deceleration time	Increase deceleration time
		Large load inertia torque or potential load	Add an appropriate dynamic brake chopper
		The frequency converter power is too low	Select a frequency converter with higher power
O.E.-1	Over voltage at constant speed	Too high input voltage of power supply	Keep the input voltage of power supply within the specified range
		Excessively reduced acceleration/ deceleration time	Increase acceleration/ deceleration time
		Abnormality in load	Check the load
O.E.-2	Over voltage during acceleration	Abnormality in input voltage of power supply	Check input power supply
		Abnormality in load	Check the load
O.E.-3	Over voltage during deceleration	Too large moment of inertia of load	Increase the deceleration time to suit the load inertia, or purchase a dynamic brake chopper

Error code	Error name	Possible reason	Solution
O.L.	Motor overload	Too large load, too short acceleration/ deceleration time or cycle	Adjust the load, acceleration/ deceleration time or cycle; or increase the frequency converter capacity
		Improper V/f characteristic curve settings	Adjust V/f curve settings
		Improper setting of electronic thermal relay	Correctly set the parameters of electronic thermal relay
O.H.	frequency converter overheat	Fan failure	Check if fan works normally
		Too high ambient temperature	Lower the ambient temperature
		Ventilation outlet obstructed	Clear dust and foreign matters at ventilation outlet
d.r.	Drive protection	Damaged power component	Replace power component and seek technical support
		Incorrect operation of drive circuit protection	Remove interference and seek technical support
CPU-	EMI	CPU incorrect operation due to external interference	Remove nearby interference or other EMI
IPH.L	Phase loss at input side	Phase loss of the frequency converter's 3-phase input power supply	Check 3-phase input power supply or seek technical support
oPH.L	Phase loss at output side	Open wire or phase loss of frequency converter's 3-phase output power supply (severe asymmetry of the 3-phase's loads)	Check frequency converter's 3-phase wiring (or symmetry of loads)
-	Motor fails to start	Abnormal power supply voltage	Check input power supply
		External wiring between control terminal SF or SR is disconnected	Check external wiring between control terminal SF or SR
		Improper parameter setting	Check parameter setting
-	Motor cannot run at different speeds	The highest frequency is too low	Check the highest frequency
		Improper frequency setting mode	Confirm frequency setting mode
-	Motor stalls during acceleration	Too short acceleration time	Increase acceleration time
		Too large inertia of motor and load	Adjust acceleration time

Error code	Error name	Possible reason	Solution
O.T.	Motor over heat	Improper V/f curve	Adjust V/f curve settings
		Continuous running at low speed	Use a special motor if it is necessary to run at low speed for a long time
		Too large load	Check the load
CPUE	EMI	CPU incorrect operation due to internal interference or damage	Remove nearby interference or other EMI

**Tab. 4-1:** Error types and solutions





## Notes

**Bosch Rexroth (Xi'an)**

Electric Drives and Controls Co., Ltd.

No. 3999, Shangji Road,

Economic and Technological Development  
Zone, 710021 Xi'an, P.R. China

Phone +49 9352 40 5060

Fax +49 9352 18 4941

service.svc@boschrexroth.de

www.boschrexroth.com



R912004884