

## Pressure and flow control system

SYDFEE series 2X, 3X

SYHDFEE, series 1X

**RE 30012-B/09.10**

Ersetzt: 08.10

English

### Operating instructions



SYDFEE, series 2X

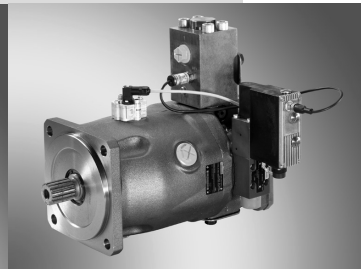

SYDFEE, series 3X



SYHDFEE, series 1X

### Valid for the following types:

Pressure/flow control system

Type SYHDFEE

Type SYDFEE

The data specified above only serve to describe the product. No statements concerning a certain condition or suitability for a certain application can be derived from our information. The information given does not release the user from the obligation of own judgment and verification. It must be remembered that our products are subject to a natural process of wear and aging.

© This document, as well as the data, specifications and other information set forth in it, are the exclusive property of Bosch Rexroth. It may not be reproduced or given to third parties without its consent.

An example configuration is shown on the title page. The delivered product may, therefore, differ from the product which is pictured.

The original operating instructions were created in the German language.

## Content

<b>1</b>	<b>About this document</b>	<b>5</b>
1.1	Related documents	5
1.2	Abbreviations used	6
<b>2</b>	<b>General safety instructions</b>	<b>7</b>
2.1	Intended use	7
2.2	Improper use	7
2.3	Personnel qualifications	7
2.4	Safety instructions in this document	8
2.5	Adhere to the following instructions	8
2.6	Operator's obligations	10
<b>3</b>	<b>Delivery contents</b>	<b>11</b>
<b>4</b>	<b>Product description</b>	<b>12</b>
4.1	Performance description	12
4.2	Device description	12
4.3	Controller structure and basic operating modes	15
4.4	Special operating modes	17
4.5	Operating pressure limits	20
4.6	Ambient conditions	22
4.7	Notes on the selection of hydraulic fluids	23
4.8	Noise level	24
4.9	Shaft variant	25
4.10	Spool variant of the VT-DFPE-x-2X pilot valve	26
4.11	Order options for the closed-loop control electronics	26
4.12	Master/slave operation	28
4.13	Identification of the product	31
<b>5</b>	<b>Transport and storage</b>	<b>32</b>
5.1	Transporting the SY(H)DFEE control system	32
5.2	Storing the SY(H)DFEE control system	34
<b>6</b>	<b>Installation</b>	<b>36</b>
6.1	Unpacking	36
6.2	Installation conditions	36
6.3	Installation positions and piping of SY(H)DFEE systems	37
6.4	Installing the SY(H)DFEE control system	40
6.5	Connecting the SY(H)DFEE control system hydraulically	43
6.6	Connecting the SY(H)DFEE control system electrically	46
<b>7</b>	<b>Commissioning</b>	<b>51</b>
7.1	First commissioning	52
7.2	Recommissioning after standstill	60
7.3	Running-in phase	61
<b>8</b>	<b>Operation</b>	<b>61</b>
<b>9</b>	<b>Maintenance and repair</b>	<b>62</b>
9.1	Cleaning and care	62
9.2	Inspection	62
9.3	Maintenance	63
9.4	Repair	63
9.5	Spare parts	63
<b>10</b>	<b>Decommissioning</b>	<b>67</b>
<b>11</b>	<b>Demounting and replacement</b>	<b>67</b>
11.1	Required tools	67
11.2	Preparing demounting	67
11.3	Demounting the SY(H)DFEE control system	67
11.4	Preparing the components for storage or further use	68
<b>12</b>	<b>Disposal</b>	<b>68</b>
12.1	Environmental protection	68
12.2	Return to Bosch Rexroth	68

12.3 Packaging .....	68
12.4 Materials used.....	69
12.5 Recycling .....	69
<b>13 Extension and conversion .....</b>	<b>69</b>
<b>14 Troubleshooting .....</b>	<b>70</b>
14.1 How to proceed for troubleshooting.....	70
14.2 Malfunction table.....	71
<b>15 Technical data .....</b>	<b>75</b>
<b>16 Annex .....</b>	<b>76</b>
16.1 Address directory .....	76
16.2 Block circuit diagram.....	77
<b>17 Alphabetical index .....</b>	<b>78</b>

# 1 About this document

These instructions contain important information on the safe and appropriate assembly, transport, commissioning, maintenance, disassembly and simple troubleshooting of the pressure and flow control systems SYDFEE series 2X, 3X and SYHDFEE series 1X.

- ▶ Read these instructions completely, especially chapter 2 “General safety instructions“ on page 7, before working with the SY(H)DFEE control system.

## 1.1 Related documents

The SY(H)DFEE control system is a system component. Also observe the instructions with regard to the other system components.

Further information on the SY(H)DFEE pressure and flow control system, its installation and operation can be found in the Rexroth documents listed in the following table.

**Table 1: Related documents**

Documentation	Contents
Order confirmation	Contains the preset technical data of your SY(H)DFEE pressure/flow control system
Operating instructions RE 90300-B	General operating instructions, which contain notes on the installation of axial piston pumps
Installation drawing	Contains the outer dimensions, all ports and connections and the hydraulic circuit diagram for your SY(H)DFEE pressure/flow control system
Data sheet RE 30030	Contains the technical data and description of the SYDFEE 2X control system
Data sheet RE 30630	Contains the technical data and description of the SYDFEE-3X control system
Data sheet RE 30035	Contains the technical data and description of the SYHDFEE control system
Data sheet RE 92711	Contains the technical data and description of the A10VSO...18...140 variable displacement pump, series 31
Data sheet RE 92714	Contains the technical data and description of the A10VSO...28...180 variable displacement pump, series 32
Data sheet RE 92050	Contains the permissible technical data for the A4VSO axial piston variable displacement pump, series 10, 11 and 30
Data sheet RE 92053	Contains the permissible technical data for the A4VSO axial piston variable displacement pump for operation with HFC hydraulic fluids
Data sheet RE 90223	Contains additional information on the use of Rexroth axial piston units with HFC hydraulic fluids
Data sheet RE 90220	Describes the requirements for an environmentally acceptable hydraulic fluid for operation with Rexroth axial piston units and assists you in selecting a hydraulic fluid for your system
Data sheet RE 29255	Contains the technical data and description of the SYDZ0001-1X pre-load valve
Data sheet RE 29016	Contains the technical data and description of the VT-DFPE-x-2X pilot valve
Data sheet RE 30268	Contains the technical data and description of the VT-SWA-1-1-X rotary angle sensor for SYDFEE
Data sheet RE 30263	Contains the technical data and description of the VT-SWA-LIN swivel angle sensor for SYHDFEE
Data sheet RE 29933	Contains the technical data and description of HM12/HM13-1X pressure transducers

## About this document

Documentation	Contents
Data sheet RE 30266	Contains the technical data and description of the HM16-1X pressure transducer
Data sheet RE 30269	Contains the technical data and description of the HM17-1X pressure transducer
Data sheet RE 07900	Describes the installation, commissioning and maintenance of hydraulic systems
Data sheet RE 30030-U	Declaration on environmental compatibility

Also observe the generally applicable, legal or otherwise binding regulations of the European and national legislation and the rules for the prevention of accidents and for environmental protection applicable in your country.

## 1.2 Abbreviations used

As umbrella term for the pressure/flow control systems SYDFEE and SYHDFEE the designation "SY(H)DFEE" will be used in the following.

**Table 2: Abbreviations**

Abbreviation	Meaning
A/F	Width across flats
A10VSO	Axial piston variable displacement pump, open circuit
A4VSO	Axial piston variable displacement pump, open circuit
EMC	Electromagnetic compatibility
NG	Nenngröße (size)
p	Pressure (symbol)
p <sub>act</sub>	Actual pressure value
p <sub>comm</sub>	Pressure command value
p <sub>Diff</sub>	Control difference between pressure command value and actual pressure value
PE	Protective earth
PT	Pressure transducer
SWA	Swivel angle
SWA <sub>act</sub>	Actual swivel angle value
SWA <sub>comm</sub>	Swivel angle command value
SYDFEE-2X	Pressure/flow control system, series 2X
SYDFEE-3X	Pressure/flow control system, series 3X
SY(H)DFEE	Pressure/flow control system, analog on-board electronics
SYHDFEE-1X	Pressure/flow control system, high pressure, series 1X
RE	Rexroth document in the English language
U <sub>B</sub>	Supply voltage
VT-DFPE	Pilot valve with integrated analog electronics
VT-SWA	Swivel angle sensor VT-SWA for control system SY(H)DFEE

## 2 General safety instructions

The SY(H)DFEE control system has been manufactured according to the generally accepted rules of current technology. There is, however, still a risk of personal injury or damage to equipment if the following general safety instructions and the warnings before the steps contained in these instructions are not complied with.

- ▶ Read these instructions completely and thoroughly before working with the SY(H)DFEE control system.
- ▶ Keep these instructions in a location where they are accessible to all users at all times.
- ▶ Always include the operating instructions when you pass the SY(H)DFEE control system on to third parties.

### 2.1 Intended use

The pressure/flow control system is intended exclusively for being integrated in a machine or installation or for being assembled with other components to form a machine or system. The product may be commissioned only if its integrated in the machine/system for which it is designed.

The pressure/flow control system is intended for the electrohydraulic control of pressure and swivel angle of an axial piston variable displacement pump.

- ▶ Observe the technical data, operating conditions and performance limits as specified in the data sheet and order confirmation.

The SY(H)DFEE control system is technical equipment, which is not intended for private use.

Intended use includes having read and understood these instructions, especially Chapter 2 "General safety instructions".

The operation of the SY(H)DFEE control system is only permitted when national EMC regulations are complied with for the application at hand. If required, notes on the installation in accordance with EMC regulations can be found in EMC test documentation of Bosch Rexroth (see RE 30030-U). The manufacturer of the system or machine is responsible for the adherence to limit values stipulated in national regulations.

- European countries: EC Directive 2004/108/EC (EMC Directive)
- USA: See National Electrical Code (NEC), National Electrical Manufacturers Association (NEMA) as well as regional construction regulations.

### 2.2 Improper use

The SY(H)DFEE control system must not be used in a potentially explosive atmosphere.

Any use of the SY(H)DFEE control system other than described in Chapter 2.1 "Intended use" is considered as improper.

### 2.3 Personnel qualifications

Assembly, commissioning and operation, disassembly, maintenance and repair require basic mechanical, hydraulic and electrical knowledge, as well as knowledge of the appropriate technical terms. For transporting and handling the product, additional knowledge is necessary with regard to working with a crane and the corresponding attachment equipment. In order to ensure operating safety, these activities may

## General safety instructions

therefore only be carried out by qualified personnel or an instructed person under the direction and supervision of qualified personnel.

Qualified personnel are those who can recognize possible hazards and institute the appropriate safety measures due to their professional training, knowledge and experience, as well as their understanding of the relevant conditions pertaining to the work to be done. Qualified personnel must observe the rules relevant to the subject area.

## 2.4 Safety instructions in this document





In this manual, there are safety instructions before the steps whenever there is a risk of personal injury or damage to equipment. The measures described to avoid these hazards must be observed.

Safety instructions are set out as follows:

SIGNAL WORD!	Type of danger!
	Consequences ▶ Precautions

- **Warning sign:** (warning triangle): draws attention to the risk
- **Signal word:** identifies the degree of hazard
- **Type of risk:** identifies the type or source of the hazard
- **Consequences:** describes what occurs when the safety instructions are not complied with
- **Precautions:** states how the hazard can be avoided.

The signal words have the following meaning:

Signal word	Application
<b>DANGER!</b> 	Indicates an <b>imminently</b> hazardous situation which, if not avoided, will certainly result in death or serious injury.
<b>WARNING!</b> 	Indicates a <b>potentially</b> hazardous situation which, if not avoided, could result in death or serious injury.
<b>CAUTION!</b> 	Indicates a <b>potentially hazardous</b> situation which, if not avoided, could result in minor or moderate injury or damage to equipment.
	If this information is disregarded, the operating procedure may be impaired.

## 2.5 Adhere to the following instructions

### 2.5.1 General instructions

- The control system SY(H)DFEE itself does not include safety functions for personnel safety and is no safety-relevant component. Safety functions for personnel safety must therefore be provided at a higher level on the system side.

**General safety instructions**

- Observe the regulations for accident prevention and environmental protection for the country where the product is used and at the workplace.
- Only use Rexroth SY(H)DFEE control systems in good technical order and condition.
  - Inspect the product for obvious defects.
- Should leakage occur or even oil jets be emitted during operation, shut the system down immediately and replace the damaged component.
- Do not modify or retrofit the SY(H)DFEE control system, except as described in Chapter 13 “Extensions and conversion” on page 69.
- Only use the product within the performance range provided in the technical data.
- Persons who assemble, commission, operate, disassemble or maintain Rexroth products must not consume any alcohol, drugs or pharmaceuticals that may affect their ability to respond.
- The warranty only applies to the delivered configuration.
- The warranty is rendered void if the product is incorrectly assembled, commissioned or operated, as well as if not used as intended and/or handled improperly.
- Do not expose the product to any mechanical loads under any circumstances. Never use the product as a handle or step. Do not place/lay any objects on it.
- The noise emission of SY(H)DFEE control systems depends on speed, operating pressure and installation conditions. The sound pressure level may rise above 70 dBA under normal operating conditions. This can cause hearing damage.
  - Always wear hearing protection while working in the vicinity of the SY(H)DFEE control system while it is in operation.
- The SY(H)DFEE control system heats up considerably during operation. The pilot valve of the SY(H)DFEE control system gets so hot during operation that you may burn yourself:
  - Allow the SY(H)DFEE control system to cool down sufficiently before touching it.
  - Wear heat-resistant protective clothing, e.g. gloves
- Hydraulic oil is flammable. Keep the control system away from fire and sources of heat and ensure sufficient venting.

**2.5.2 During transport**

- Make certain that the lifting gear has adequate lifting capacity. The weight can be found in Chapter 5 “Transport and storage” on page 32.

**2.5.3 During installation**

- Before installing the product, make sure that all fluids have been completely removed from the SY(H)DFEE control system to prevent mixing with the hydraulic fluid used in the hydraulic system.
- Make sure the relevant system component is not under pressure or voltage before assembling the product or when connecting and disconnecting plug-in connectors. Protect the system against being switched on.
- Observe installation notes as well as the strength classes and tightening torques specified for screws.
- Lay cables and lines so that they cannot be damaged and no one can trip over them.
- Before commissioning, make sure that all hydraulic connections are tight and that all the connection seals and plugs are installed correctly to ensure that they

## General safety instructions

are leakproof, and fluids and contaminants are prevented from penetrating the product.

- When installing the product, provide for absolute cleanliness in order to prevent contaminants such as welding beads or metal cuttings from getting into the hydraulic lines and causing product wear or malfunctions.

### 2.5.4 During commissioning

- Let the product acclimate itself for several hours before commissioning, otherwise water may condense in the housing.
- Make sure that all electrical and hydraulic connections are either used or plugged. Commission the product only when it is installed completely.

### 2.5.5 During cleaning

- Plug all ports and open connections with the appropriate protective equipment in order to prevent detergents from penetrating the system.
- Never use solvents or aggressive detergents. Use only water and, if necessary, a mild detergent to clean the SY(H)DFEE control system.
- Do not use a high-pressure cleaner for cleaning.

### 2.5.6 During maintenance and repair

- Perform the prescribed maintenance work at the intervals specified in the operating instructions (see Chapter 9.3 "Maintenance" on page 63).
- Make sure that no lines, connections or components are disconnected as long as the system is under pressure. Protect the system against being switched on.

### 2.5.7 Disposal

- Dispose of the product and the hydraulic fluid in accordance with the currently applicable national regulations in your country.

## 2.6 Operator's obligations

The operator of the SY(H)DFEE control system from Rexroth must provide personnel training on a regular basis regarding the following subjects:

- Observation and use of the operating instructions and the legal regulations
- Intended use and operation of the SY(H)DFEE control system
- Observation of the instructions from the factory security offices and of the work instructions from the operator



Rexroth offers training support for special fields. You can find an overview of the training contents on the Internet at:

<http://www.boschrexroth.de/didactic>.

### 3 Delivery contents

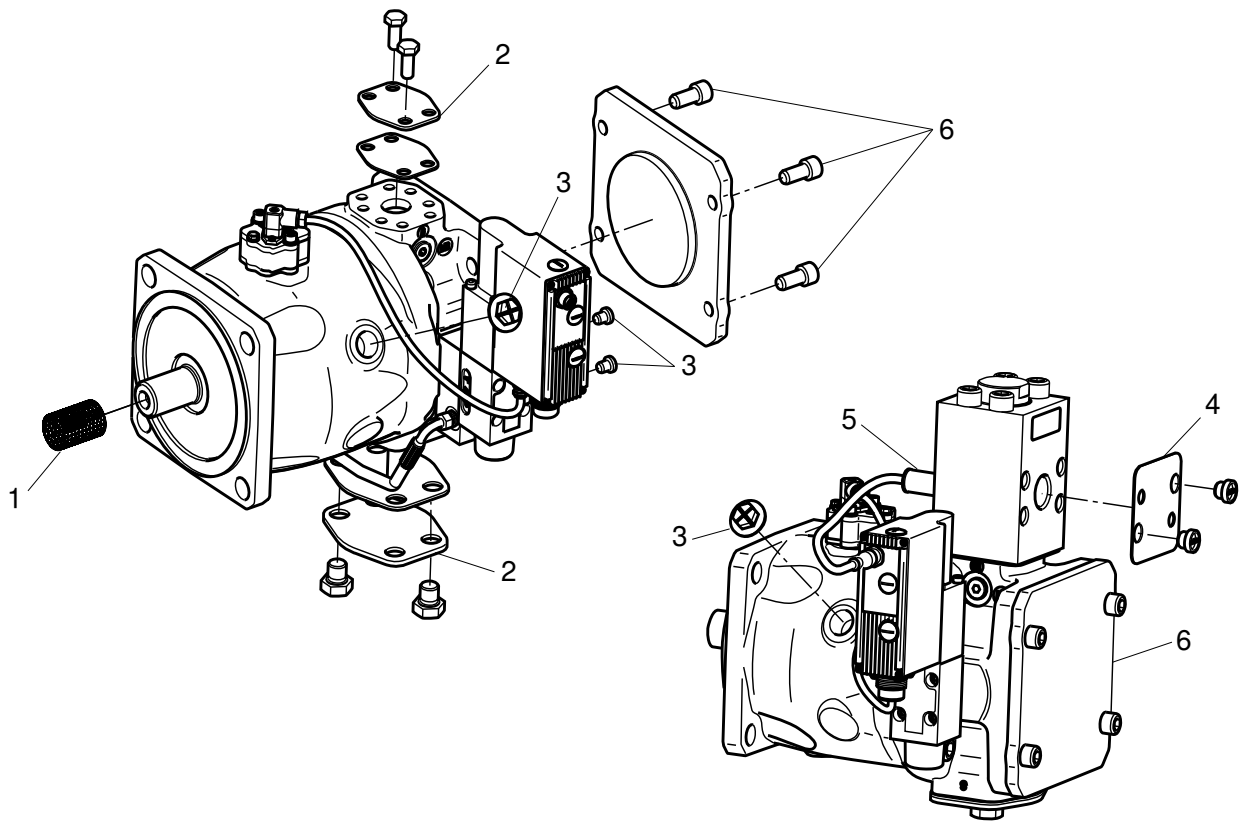

Fig. 1: Control system SYDFEE-3X

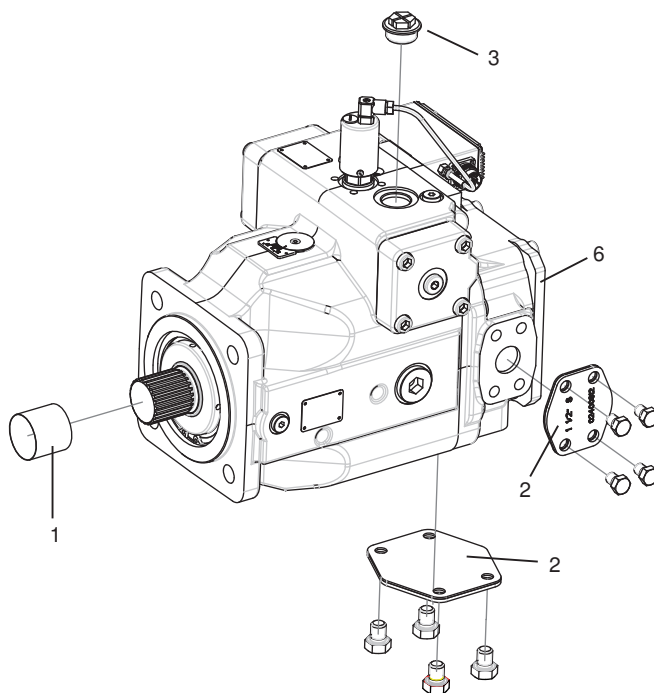

Fig. 2: Control system SYHDFEE

The following is included in the scope of delivery:

- 1 control system SY(H)DFEE

When delivered, the following parts are mounted additionally:

- Transport protection for drive shaft end for keyed shaft (1)
- Protective cover (2) with mounting screws
- Plastic plugs/plug screws (3)
- Protective cover (NG140) or plastic plug (NG18...100) on preload valve (4)
- Pressure transducer (optional) (5)
- The connection flange is closed operationally safe with a cover (optionally on variant with through-drive) (6).

## 4 Product description

### 4.1 Performance description

The SY(H)DFEE control system is designed and built for the electrohydraulic control of swivel angle, pressure and power (optional) of an axial piston unit. It is intended for stationary applications.

Please refer to the data sheet and order confirmation for the technical data, operating conditions and operating limits of the SY(H)DFEE control system.

### 4.2 Device description

The SY(H)DFEE control system is based on an axial piston variable displacement pump of swashplate design for hydrostatic drives in the open circuit. The flow is proportional to drive speed and displacement. The flow can be steplessly changed by adjusting the swashplate.

#### Open circuit

With an open circuit, the hydraulic fluid flows from the tank to the variable displacement pump and is transported from there to the consumer via a directional valve. From the consumer, the hydraulic fluid flows back to the tank through the directional valve.

In the regenerative operating mode (Chapter 4.4.1 on page 19) the hydraulic fluid can also flow from the consumer through the pump to the tank.

#### 4.2.1 Functional description, section of the SY(H)DFEE

The numbers in the following description refer to Fig. 3, 4 and 5 on page 13/14.

The pressure and swivel angle of the A10VSO variable displacement pump of the SY(H)DFEE control system is controlled using an electrically operated proportional valve (2). The proportional valve determines the position of the swashplate (1) by means of the actuating piston (4). The displaced flow is proportional to the position of the swashplate. The counter-piston (3), which is preloaded by a spring (5), is permanently pressurized to pump pressure.

With a non-rotating pump and depressurized actuating system, the swashplate is held by the spring (5) in position +100 %. With a driven pump and a de-energized proportional solenoid (8) the system swivels to zero stroke pressure as the valve spool (9) is pushed to the initial position by the spring (10) and, therefore, pump pressure  $p$  is applied to the actuating piston (4) via valve port "A". A balance between the pump pressure on the actuating piston and the spring force (5) is achieved at a pressure of 8 to 12 bar. This basic position (= zero stroke operation) is obtained e.g. when the valve electronics is de-energized.



In contrast to this, a pump with external supply swivels to the negative limit stop (regenerative operation). See also section "Basic positions of swivel angle adjustment feature" on page 14.

The proportional valve is controlled by analog electronics (11), which is integrated in the valve. This closed-loop control electronics processes all of the control signals required to operate the A10VSO variable displacement pump under closed-loop pressure and flow control.

The closed-loop control electronics is provided with a command value input each for pressure and swivel angle on the central plug (12); for the optional power limitation, the command value can be adjusted using an internal potentiometer or be provided via an analog value, depending on the specification in the order. A pressure transducer can be connected to the central plug (12). Alternatively, with order option "F" (actual pressure value input), an HM16 pressure transducer can be connected using an M12 mating connector (13). This pressure transducer can

be mounted and connected to port P of the pump or, in the case of control system SYDFEE with an SYDZ pre-load valve, to port MP1.

A position transducer with integrated electronics (7) fitted to the pump establishes the actual swivel angle value. The acquired actual values are processed in the amplifier and compared with the given command values. The minimum value comparator ensures that automatically only the controller is active that is assigned to the required working point. Thereby, a system variable (pressure, swivel angle or [optionally] power) is exactly controlled, the other two values are below the specified command values. The output signal of the minimum value comparator becomes the command value for the valve control loop.

The actual value of the valve spool position is sensed using an inductive position transducer (6). The output value of the valve position controller determines via the amplifier output stage the current through the proportional solenoid (8). As soon as the working point is reached the proportional valve control spool (9) is held in the central position.

When the higher-level controllers demand an increase in the swivel angle (increase in flow), the valve spool (9) must be moved from the central position (connection of the actuating piston (4) A → T) until the swivel angle reaches the required value. The movement of the valve spool against the force of the spring (10) is achieved by a corresponding increase in the electrical current through the proportional solenoid (8).

A reduction of the swivel angle (reduction in flow) is achieved by connecting the actuating piston (4) from P → A.

**Actuating system supply** The actuating system of the pump can be supplied with pilot oil in three different ways:

1. Internal, without pre-load valve (only possible for operating pressures > 12...20 bar, see Chapter 4.5 on page 20)
2. Internal, with pre-load valve (operating pressure 0...100 %)
3. External supply via a shuttle valve - automatic changeover between internal/external via a shuttle valve sandwich plate (see 4.5.1 "External pilot oil" on page 21)

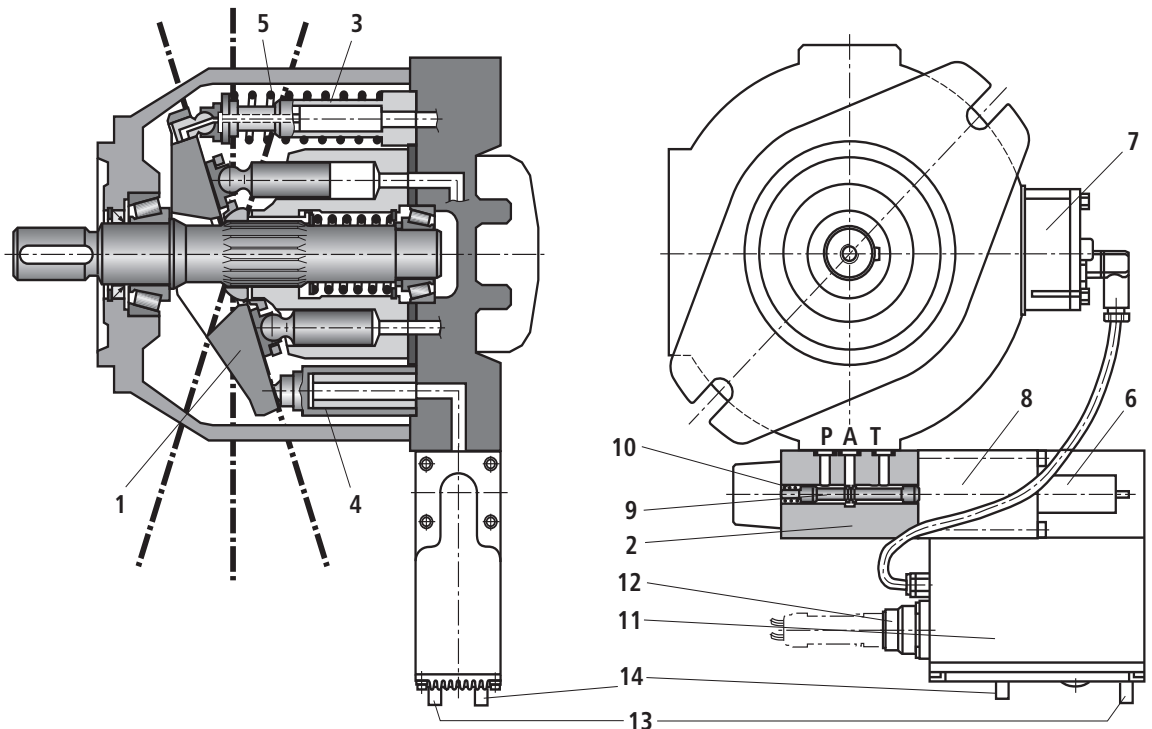

Fig. 3: Type SYDFEE, series 2X

(M12) for HM16, variant "F" only

Product description

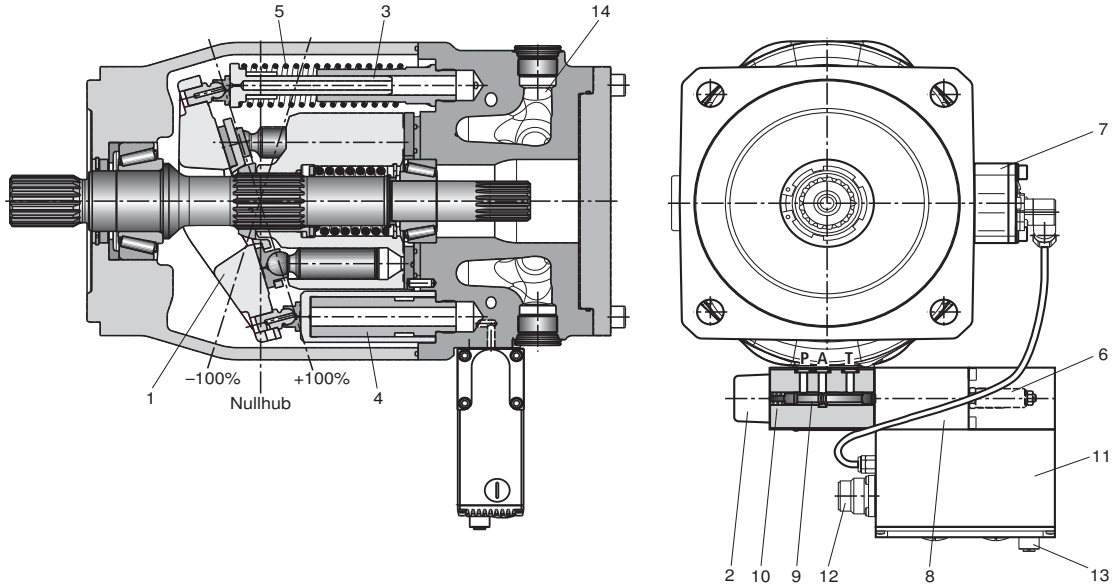

Fig. 4: Type SYDFEE, series 3X

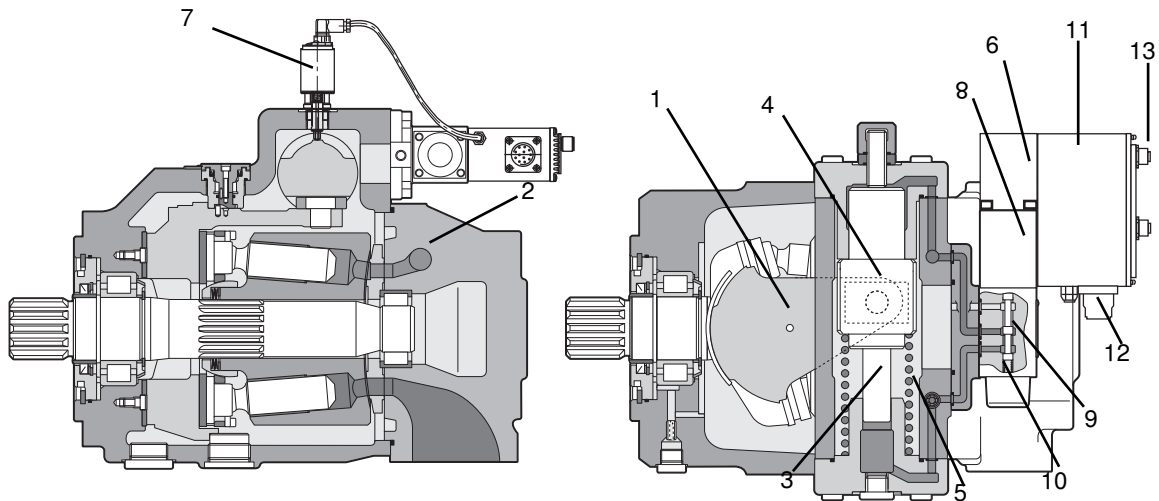

Fig. 5: Section of SYHDFEE, series 1X

**Basic positions of swivel angle adjustment feature**

The sectional drawings above show the mechanical basic position “+100 %” of the pump (depressurized, drive at rest). This corresponds to the maximum swivel angle of the pump.

Zero stroke pressure: Pressure, which the pump with internal supply generates for its own supply without activation of the pilot valve. The pressure level is usually within the range of 8 to 12 bar. This pressure level can only be achieved when the maximum oil flow, which the pump can deliver, is not exceeded (the consumer line is closed). The pump with **internal supply** automatically swivels in to zero stroke operation after the electric drive was started and when the control electronics is **de-energized**, provided that the required pilot pressure can build up (consumer line is closed).

In contrast to this, the pump with **external supply** swivels in to the **negative limit stop “-100%”** when the control electronics is **de-energized!**

**CAUTION!****Risk of damage to the pump!**

On systems with external supply, the pump may cavitate.

- ▶ To avoid damage to the pump, a pressure relief/anti-cavitation valve must be provided for systems with external supply. If a fault occurs during operation - not during start-up - the motor must be switched off.

### 4.3 Controller structure and basic operating modes

**Controller structure** The controller structure is illustrated in the figure below

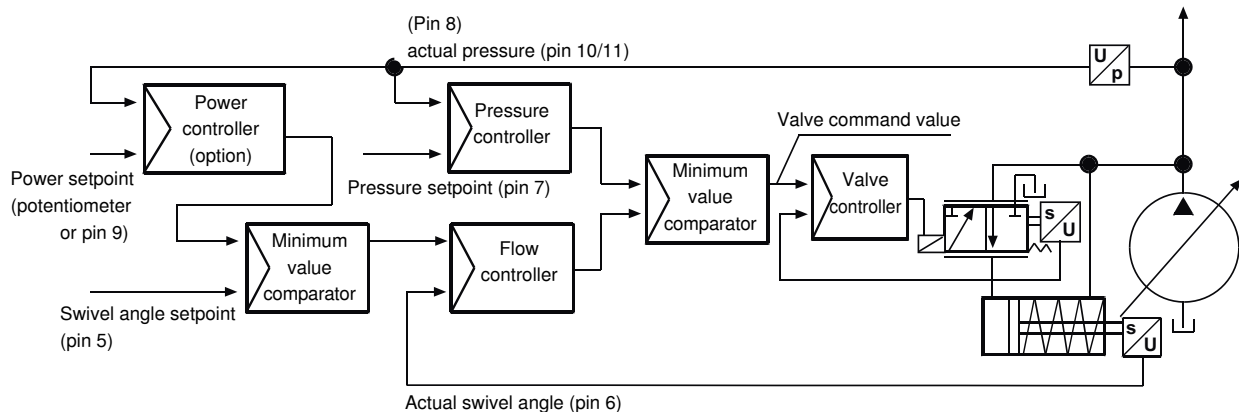

**Fig. 6: Controller structure**

**Basic operating modes** Up to three controllers are continuously active in the possible operating modes:

- Swivel angle controller
- Pressure controller
- Power controller (optional)

These controllers alternate automatically and jerk-free through evaluation of minimum value comparators.

During steady-state operation, one of the above controllers is active. For the other controllers, the actual value is smaller than the command value.

The following operating modes are available:

#### 4.3.1 Closed-loop swivel angle control

If the axis is to run exclusively in this operating mode, an analog signal within the range of +10.0 V to  $U_B$  is assigned to the pressure command value and used to deactivate the pressure controller ( $0 \dots +10 \text{ V} \triangleq 0 \dots 100 \text{ \% swivel angle}$ ).



The pressure transducer signal should be short-circuited or deactivated, because even actual pressure value signals of  $\geq 8.0 \text{ V}$  have an influence on or reduce the swivel angle output and hence the valve command value (actuating speed!).

A precondition for this is, however, that the electronics is designed for an actual pressure input "voltage" without raised zero point (offset). Otherwise, the electronics, which is selected for an actual value branch with raised zero point (e.g. 4...20 mA or 0.5... V), would be in an erroneous state when the pressure transducer signal is missing.

Product description

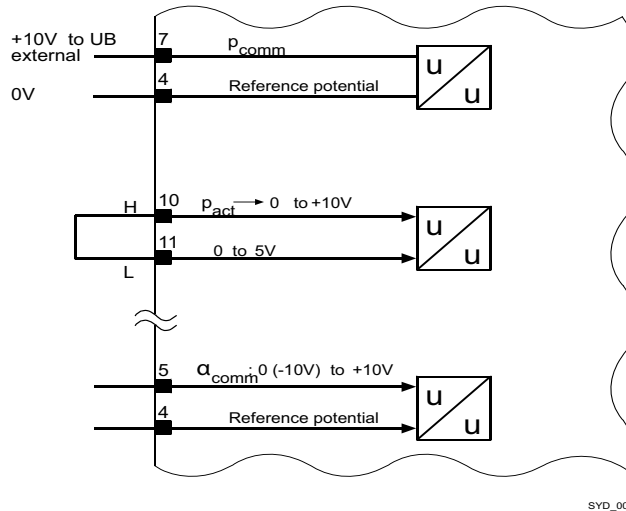

Fig. 7: Circuitry of integrated electronics VT-DFPE...-2X/V for closed-loop swivel angle control

4.3.2 Closed-loop pressure control

If the axis is to operate in this mode, an analog signal within the range from +10.0 V to  $U_B$  can be assigned to the swivel angle command value and used to deactivate the swivel angle controller. However, for some applications, it is advantageous to limit the swivel range of the pump by feedforwarding a suitable swivel angle command value. However, this command value must be sufficiently great in order that the pressure controller can swivel out the pump to the required extent.

**WARNING!**



**Risk of personal injury and damage to material!**

Excessive pressure can cause the pipes to burst. Parts may fly around and oil be ejected under high pressure, which can result in serious injury. The electrical pressure control does not assume a pressure relief function.

- ▶ If no pre-load valve is used, install a pressure relief valve, which is set 10 % higher (recommendation) than the operating pressure.

4.3.3 Power limitation (options B and C)

This version allows optimum matching with the performance limits of the drive motor.

Due to the relationship of  $P \approx \alpha_{comm} * p_{act}$  the power controller intervenes with a reducing/limiting effect (power hyperbola) via the swivel angle command value branch, if required.

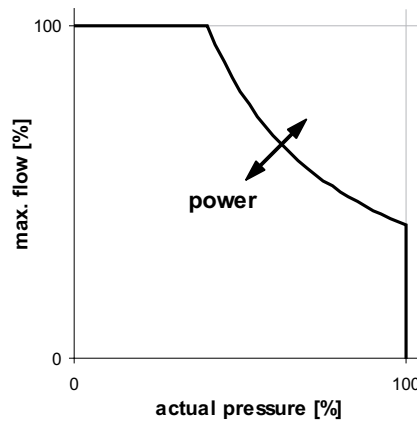

Fig. 8: Power limitation

#### 4.4 Special operating modes

This chapter describes certain applications. In these cases, the basic operating modes (see Chapter 4.3, page 15) are active.

##### Starting up at zero pressure

For starting up SY(H)DFEE systems, no hydraulic circuit needs to be provided for the classical start-up at zero pressure.

When small command values for pressure and swivel angle are provided, starting up under almost no-load conditions is possible.

##### Circulation operation (by-pass filtration, cooling)

In the case of systems with internal supply and without pre-load valve, hydraulic circulation circuits must be dimensioned so that a minimum pressure between 8...12 bar is obtained, because the pump requires this pressure level in order to be able to respond to electrical control signals.

##### Stand-by operation

Operating mode of the pump, in which an operating point is statically closed-loop-controlled with a corresponding command value over a longer period of time.

Observe the notes on permitted pressures in Chapter 4.5.1 "Internal/external pilot oil" (page 21).

##### Zero stroke operation

Operating mode of the pump that refers to the smallest, achievable swivel angle and to which the pump usually changes over when no closed-loop control is active.

Zero stroke operation can be definitely achieved only by means of a minimum command value feedforward in the closed swivel angle control loop.

The feedforward of "0 bar" via the pressure command value branch is not permitted for actuating systems with external supply. In the case of systems with internal supply this is problematic only in the case of a step-change from a high pressure to 0, because undershoots may occur.

The following is valid when the valve electronics is de-energized:

- Zero stroke operation for the internally supplied pump
- Swiveling out to "-100%" of the externally supplied pump

Product description

4.4.1 Regenerative operation

Regenerative operation is a special operating mode of the SY(H)DFEE control system, since in this case the SY(H)DFEE control system is operated as both, generator and motor.

Continuous regenerative operation

We can distinguish between continuous regenerative operation and brief regenerative operation. In the first case, by this we understand coupling of the variable displacement pump with a fixed displacement pump. Here, the two pump displacements are combined and fed to a common consumer.

This operating mode can be utilized in conjunction with a fixed displacement pump in order to increase the displacement. To achieve “zero” displacement, the closed-loop controlled pump must “take over” the entire flow from the fixed displacement pump and therefore swivels to the negative swivel angle range (motor operation). It must be noted here that both pump sizes must be matched to each other in a way that the controlled pump (in regenerative operation) must swivel in to max. “-70 %“. The fixed displacement pump should be mounted to a through-drive of the SY(H)DFEE control system.

The following pump variants are available for continuous regenerative operation:

0487: Continuous regenerative operation with external supply

0541: Continuous regenerative operation without external supply (for SYDFEE-3X only)



In the case of pump variants with external supply this operating mode is somewhat complicated in terms of engineering and commissioning, because a pump swiveling in too far (e.g. -75 % instead of -70%) causes cavitation. We therefore recommend master/slave operation as an alternative with two closed-loop controlled SY(H)DFEE systems or pump variant 0541 for SYDFEE-3X.

Continuous operation is possible when the given operating limits are adhered to. However, at a total displacement of “zero” (that is, at a negative swivel angle of the SY(H)DFEE pump) and at high pressures, the noise level increases and efficiency deteriorates.

For pumps with external supply, the use of a pressure relief and anti-cavitation feature as shown in Fig. 9 is indispensable to prevent the pump’s running dry.

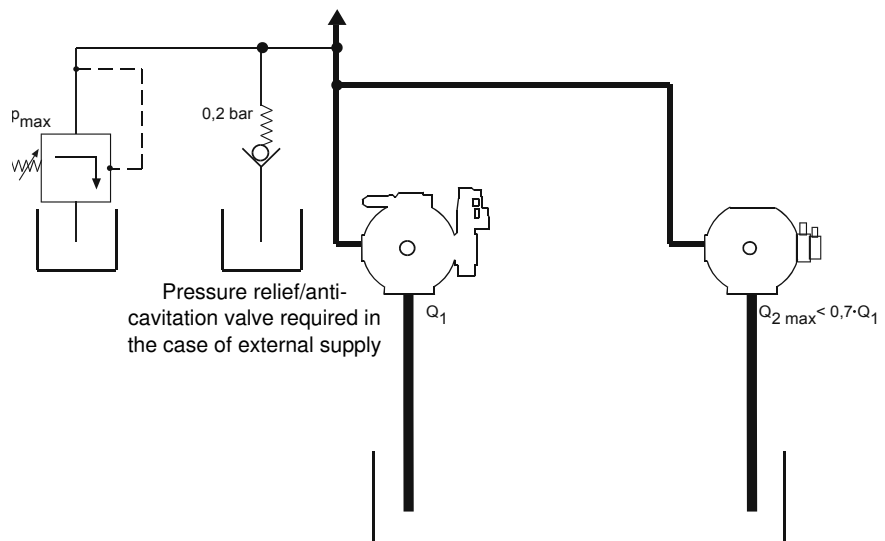

Fig. 9: Circuit diagram for continuous regenerative operation

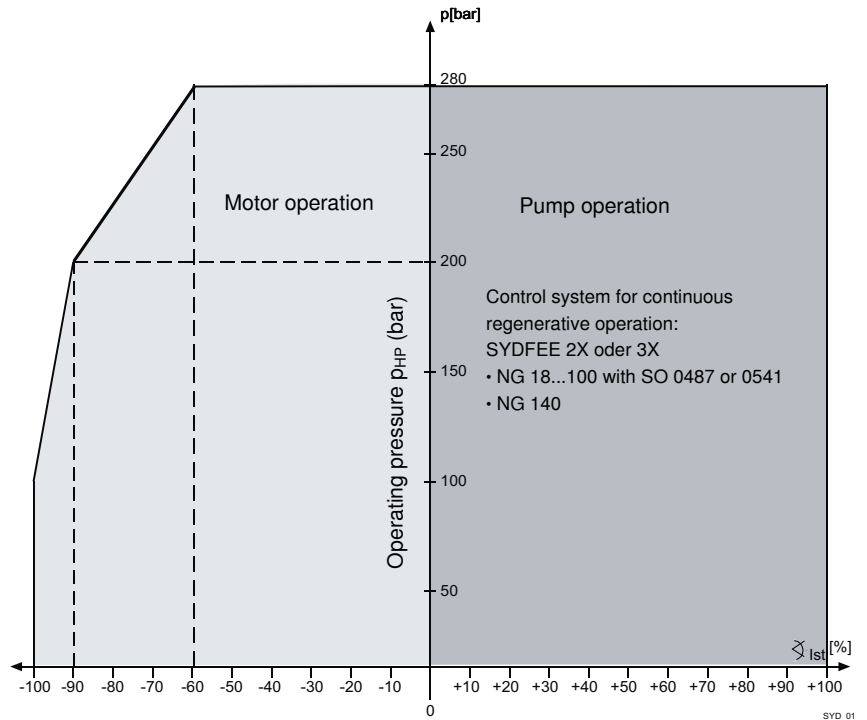

Fig. 10: Operating limits for series SYDFEE-2X and SYDFEE-3X with special rotary group for continuous regenerative operation

**Brief regenerative operation**

During brief regenerative operation the variable displacement pump changes over to motor operation for a limited period of time, e.g. for lowering a load. If the requirement profile remains within the limits according to Fig. 11, the standard version of the pump can be used (standard rotary group 0000 or 0479).

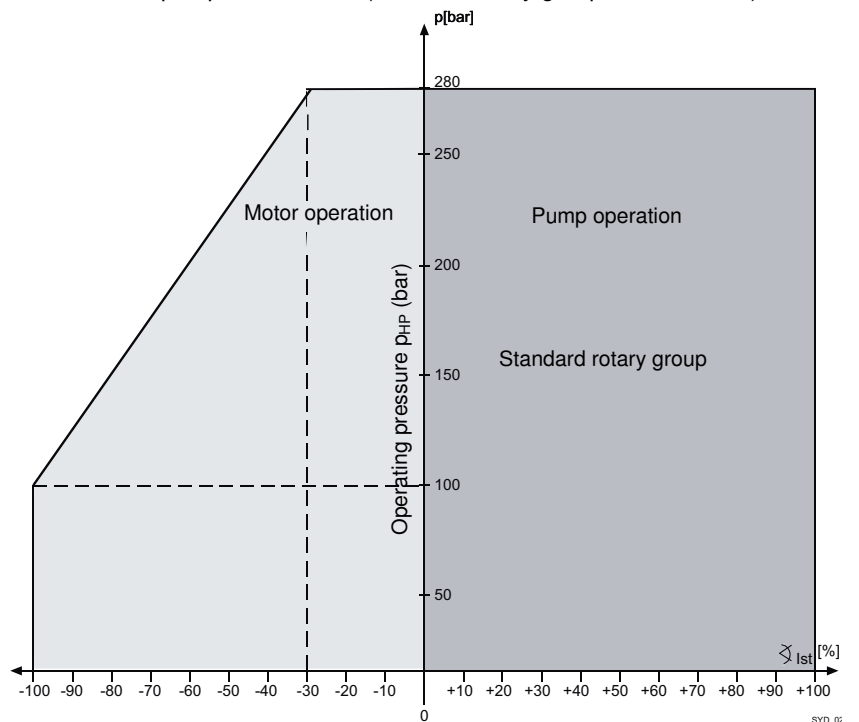

Fig. 11: Operating limits for series SYDFEE-2X and SYDFEE-3X with standard rotary group for brief regenerative operation

## Product description

**Regenerative operation for SYHDFEE-1X**

With series SYHDFEE-1X we do not differentiate between brief and continuous regenerative operation. The operating limits are shown in Fig. 12, otherwise observe the notes given on continuous regenerative operation and brief regenerative operation on the previous pages.

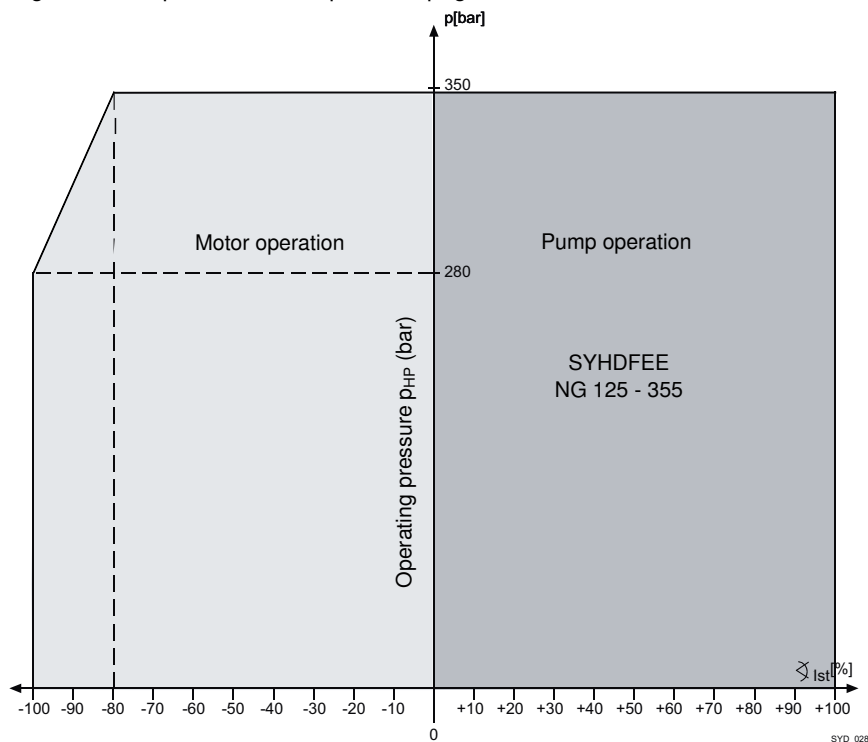

Fig. 12: Operating limits for SYHDFEE

## 4.5 Operating pressure limits

### WARNING!



#### Ejecting parts and fluid jets!

Risk of injury! The electrical pressure control does not assume a pressure relief function.

- ▶ Make sure that the maximum operating pressure is not exceeded.
- ▶ If a pre-load valve is installed, you can use its pressure relief function. If no pre-load valve is provided, install a pressure relief valve in the pressure line, the pressure setting of which is 10 % (recommended) higher than the operating pressure. If you do without this valve, the pump can be damaged due to malfunction.

### Maximum operating pressure

The maximum operating pressure specified in the data sheet must not be exceeded.



At a pressure of  $\geq 250$  bar the following restrictions must be observed for SYDFEE:

- The pressure transducer must be located downstream of a pulsation damper or the high-pressure hose.
- When a standard pilot valve spool is used (version "A"), the pressure controller P-gain (SO version of VT-DFPE valve) may have to be reduced. This has an influence on the accuracy and dynamics of the closed pressure control loop.

- The loop gain can also be reduced by installing a pressure transducer of a higher pressure rating (e.g. 400 bar).

**Minimum operating pressure** The minimum operating pressure depends on the pilot oil supply and is explained in more detail in the following chapters.

#### 4.5.1 Internal/external pilot oil

**Internal pilot oil supply** If the operating pressures of the application are always > 20 bar, the version with internal pilot oil supply should be selected, because cavitation due to too small command values is impossible with this version.

Operation is also possible at pressures higher than approximately 12 bar, but dynamics is restricted within the range below 20 bar.

This minimum (pilot) pressure level ensures that the pump can respond to the electrical swivel signal at any time. When the consumer line is blocked, the smallest achievable swivel angle is zero stroke.

For applications, in which smaller operating pressures occur or are to be controlled, a pre-load valve (SYDZ for SYDFEE) can be used. For this solution, the minimum pressure is  $\geq 1$  bar.

**Pre-load valve** The advantage of the pre-load valve is that the pilot oil pressure of the pump cannot fall below the value preset on the pre-load valve and that pressures  $\leq 10$  bar on the output side can be continuously controlled.

Being equipped with a pre-load valve the pump cannot permanently swivel back over zero irrespective of electrical actuating signals or any control errors. This is not valid for applications, in which, for example, a suspended load can cause operating pressures  $\geq 12$  bar. In such cases the pump can also be used in motor operation (for lowering the load). A check valve integrated in the pre-load valve permits, within certain limits, a reversal of the direction of oil flow.



When using pump combinations

- NG45 with 45/28/18 or
- NG28 with 28/18 or
- NG18 with 18

in conjunction with the SYDZ pre-load valve on the main pump, there is a mechanical conflict between port "P1" of the pre-load and the position transducer housing of the rear pump fitted. For this reason, we suggest that the main pump of the above combinations be equipped with an SAE flange plate  $\frac{3}{4}$ " (NG28) or 1" (NG45) having a height of  $h = 45$  mm. The construction height of the pump assembly therefore changes by dimension "h".

**External pilot oil supply** Also here, the minimum pressure is  $\geq 1$  bar. With external pilot oil supply (0479 for external supply or 0487 for external supply plus regenerative operation for SYDFEE; 0576 for SYHDFEE) pressures  $\leq 10$  bar are only permitted briefly (max. 10 minutes).

An additionally built-on sandwich plate with shuttle valve automatically switches the pilot oil supply between the internal or external pilot oil source, with always the higher pressure level being selected.

A pump with external pilot oil supply can be recognized by

- the sandwich plate mounted below the pilot valve and
- the hose routed around the pump case.

On the SYHDFEE control system, the Z-port is located next to the swivel angle transducer.

## Product description

With external pilot oil supply, the actuating system of the SY(H)DFEE pump works independently of the actual high-pressure circuit, thus allowing an adjustment also below an operating pressure of 12 bar within the range of “±100 %” (change in the direction of displacement!).



When the control electronics is deactivated, the pump swivels to position “-100 %” (motor operation) in an uncontrolled manner. This can lead to cavitation and damage to the pump.

For this reason, special features are to be provided such as a pressure relief and anti-cavitation valve and actual swivel angle value monitoring.

The pressure relief and anti-cavitation valve diminishes the risk of the pump's running dry, the effects of which result in a reduction in the pump's service life.

The actual swivel angle value monitor could, for example, switch off the entire drive or selectively shut off the pilot oil flow.

The following is valid for the actuating pressure:

$$\text{Pilot oil pressure} \leq \text{minimum operating pressure} + 30 \text{ bar}$$

Recommendation: Absolute pilot oil pressure  $\approx$  20 bar

Further notes on the operation with external supply:

- In the case of external supply, the pump does not swivel to zero stroke when the pilot valve is de-energized.
- Command values for pressure and flow must always be greater than 1 bar or 5 %, because there is no exact “zero” pressure or “zero” swivel angle due to drift or inaccurate settings. For this reason, selections equal to zero or slightly greater can lead to cavitation in unfavorable cases.
- In order to ensure sufficient lubrication for the pump system at all times, the actual pressure value must not be less than 10 bar for longer than 10 minutes!

### Notes on dimensioning

At a pilot oil pressure of 20 bar the brief pilot oil requirement during swiveling is ca. 17 l/min; at 50 bar (SYHDFEE) it is ca. 25 l/min. In practice, this amount of pilot oil is needed only, if the operating pressure is less than 20 bar during the entire swiveling process and thus the entire pilot oil demand must be supplied by the external source.

In the steady-state, balanced condition, the pilot oil requirement is less than 1 l/min.

Experience has shown that, depending on the operating pressure and swiveling frequency, the actual pilot oil demand is in the order of 5...15 l/min. In the case of external supply, a smaller pump size may be selected if an accumulator is provided.

## 4.6 Ambient conditions

### 4.6.1 Oil-immersed applications



Only the SY(H)DFE1 control system is suitable for oil-immersed applications. SY(H)DFEx systems with integrated electronics must not be immersed.

### 4.6.2 Ambient temperature

The permissible maximum ambient temperature for the SY(H)DFEE control systems is 60 °C.



We recommend the installation within a ventilated area with moved ambient air, e.g. in the air flow of an electric motor.  
This is valid in particular in view of the place of installation of the integrated electronics.

## 4.7 Notes on the selection of hydraulic fluids

### General

The SYDFEE control system is designed for operation with hydraulic fluids in accordance with DIN 51 524 (HL/HLP). The use of HFC is permitted only for SYHDFEE with option "F".

### Operating viscosity

We recommend that the operating viscosity (at operating temperature) be within the following range, which is optimum in terms of efficiency and service life:

- $\nu_{opt}$  = optimum operating viscosity 16...36 mm<sup>2</sup>/s.

This range is referred to the tank temperature in the open circuit.

### Viscosity limits

The following values are valid for limiting operating conditions:

- $\nu_{min}$  = 10 mm<sup>2</sup>/s  
Briefly, at max. permissible leakage oil temperature of 90 °C
- $\nu_{max}$  = 1000 mm<sup>2</sup>/s  
Briefly, during cold start

### Temperature range

The temperature of the hydraulic fluids lies between the following values: (cf. selection diagram)

- $t_{min}$  = -20 °C
- $t_{max}$  = 70 °C

### Selection diagram for the hydraulic fluid

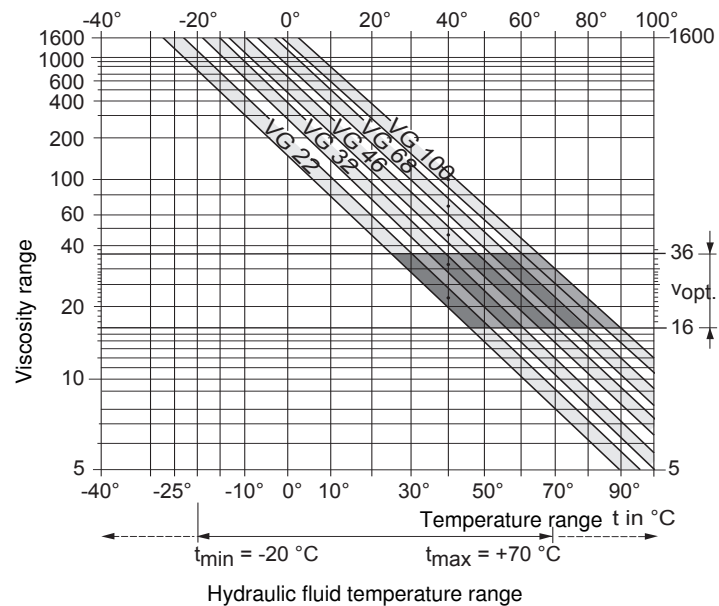

## Product description



### Notes on the selection

In order to be able to select the correct hydraulic fluid, the operating temperature in the tank (open circuit) in relation to the ambient temperature must be known.

The hydraulic fluid should be selected so that within the operating temperature range, the operating viscosity is within the optimal range ( $v_{opt}$ ). This range is shown as shaded area in the selection diagram.

We recommend that you select the next higher viscosity class.

Example:

At an ambient temperature of X °C, the resulting temperature in the tank is 60 °C. Within the optimum operating viscosity range ( $v_{opt}$ ; grey-shaded area) this corresponds to viscosity classes VG 46 and VG 68. You should select: VG 68.



The case drain oil temperature, which is subject to the influence of pressure and pump revving speed, is always higher than the tank temperature. However, the temperature must not exceed 90 °C at any point in the system. If the conditions described above cannot be complied with due to extreme operating parameters or high ambient temperatures, please consult us.

## Filtration of the hydraulic fluid

The finer the filtration of the hydraulic fluid, the better is the achieved cleanliness class, which, in turn, prolongs the service life of the SY(H)DFEE control system.

To ensure operational reliability of the SY(H)DFEE control system, at least cleanliness class 18/16/13 according to ISO 4406 (for particle sizes 4/6/14  $\mu\text{m}$ ) is required.

## HFC fluids



The use of HFC fluids is permitted only for SYHDFEE control systems with option "F". For applications with HFC fluids, it must be noted that, due to the reduced lubrication ability of HFC fluids, the service life of the SYHDFEE control system is reduced when compared with the standard application. For applications with HFC fluids, the 4-groove spool must be used for the pilot valve. The spool is specified by "C" in the ordering code of the SYHDFEE control system.

For commissioning pump systems that are operated with HFC fluids, please read the relevant commissioning instructions (among others, RE 92053), which are available as separate documents.

## 4.8 Noise level

For design-inherent reasons, when compared with vane pumps, axial piston pumps generate greater changes in flows and thus pressure pulsations. Apart from the propagation of air and structure-borne noise, this can have an influence on fluid-borne noise. In the end, these factors together result in the general perception of "noise".

Noise often induces vibration on other components, which, in turn, also generate noise. For example, on check valves, which may be installed, the integrated springs must be adapted to the conditions of the systems, if this is a cause of excitations leading to the generation of noise.

The details given for the noise pressure level in the technical documentation refer to measurements taken in an anechoic room. Influences of the surroundings such as place of installation, general mechanical concept, piping, etc. are not taken into account.

#### 4.8.1 Generation of noise in the power unit

“Noise” is composed of different elements. The total result of “noise” is influenced not only by air-borne noise, but also by structure- and fluid-borne noise.

As a result of unfavorable installation and piping conditions, the noise pressure level of the complete system can be 5 to 10 dB(A) higher than the value of the pump alone.

Noise can be reduced by taking, for example, the following measures:

- Low-noise tank
- Damping ring between pump and pump mounting bracket
- Flexible pipe conduit
- Anti-vibration rails under the motor
- Installation of the pump at a sufficient distance to the tank wall

#### 4.8.2 Pulsation damper

For some special applications, we recommend the use of a pulsation damper.

Due to the reduction of typical pump pressure pulsation, this has a positive effect on the noise level of the hydraulic system as a whole.

Further information can be found in data sheet RE 50142.

#### 4.9 Shaft variant

The SY(H)DFEE control system is available with keyed or splined shafts. When compared with the keyed shaft, the splined shaft is not only advantageous with regard to its degrees of freedom during assembly and operation, but also due to its increased torque load carrying capacity and its stability under changing loads.

This increased torque load carrying capacity is useful in particular when pump combinations are to be installed. In the case of multiple pumps, all built-on units are fitted with splined shafts.

In view of the dynamic load carrying capacity and standardization, we recommend the use of standard types with splined shafts. This offers advantages with regard to availability and future spare parts requirements.

When a splined shaft is selected, a clamp coupling must be used for the mechanical connection to the electric motor. Otherwise, frictional corrosion may occur that leads to damage to the pump.

Notes on the permissible maximum transmission of torques can be found in the data sheet.

#### Keyed shaft

Due to the advantages of the splined shaft, keyed shafts are not recommended for new applications. The keyed shaft is no longer used for applications with through-drive.

If a single pump is to be used later as “end pump” in a multiple-pump system, a splined shaft must be selected.

## Product description

### Splined shaft

Splined shaft profiles depend on the size (NG) of the pump. Two different splined shaft profiles are available in conjunction with "SY(H)DFEx" :

- "S"-profile for NG18, NG100 and NG140
- "R"-profile for NG28 ... 71

When compared with the "S"-profile, the "R"-profile offers further improved properties with regard to the torque carrying capacity of the shaft. This version represents the optimum for a wide variety of applications.

### 4.10 Spool variant of the VT-DFPE-x-2X pilot valve

The standard spool according to the ordering code is spool type "A" (360° spool). Especially for press applications (280 bar) type "C" (4-groove spool) has proven in practice in conjunction with the SYDFEE control system.

The 4-groove spool of type "C" is also allocated to SYHDFEE as standard for applications using HFC media.

### 4.11 Order options for the closed-loop control electronics

The control electronics of analog SY(H)DFEE systems are designed so that only the controller parameters for "pressure" can be variably adjusted. For closed-loop swivel angle control a fixed parameter setting is provided for all sizes.

The following variants of the control electronics can be ordered optionally:

Ordering code:

- A Standard, without power limitation, pressure controller with changeover feature  
Pin 9 = switching input "changeover of controller setting"
- B With power limitation using the integrated potentiometer  
Pin 9 = switching output "power limitation reached"
- C Power limitation with variable selection  
Pin 9 = analog input "power limit" 0...10 V
- D Pressure controller that can be switched off (High signal)  
Pin 9 = switching input "deactivate pressure controller"

Pin 9 = Switch T<sub>D</sub>

#### 4.11.1 Pressure controller with changeover feature

The PD-controller can be optimally adjusted to the properties of the system by means of the rotary switch provided for this purpose.

You can select from various PD-controller settings in dependence on the oil volume. Here, the P-component is fixed, whereas the D-component can be varied from 0 to F by means of rotary coding switch S1.

If you select variant "A" = without power limitation, a further controller parameterization, which is assigned to the relevant position of the rotary switch (switch "T<sub>D</sub>"), can be called up via the existing switching input.

#### 4.11.2 Case drain oil compensation

As the operating pressure rises, the amount of internal leakage of the SY(H)DFEE control system increases.

For this reason, a certain external swivel angle command value is applied in order to exercise a pressure-dependent influence on the pump's displacement:

The displacement of the pump decreases at higher pressures.

The standard versions of the various control electronics therefore comprise an automatic case drain oil compensation feature that constantly adds a certain percentage of the actual pressure value as correction factor to the swivel angle command value. This, however, results in differences between the externally provided swivel angle command value and the actual swivel angle signal when this compensation feature cuts in.

For integral analog electronics, the deactivation of the compensation feature can be ordered as an optional extra.

In certain applications and with integrated, connected pressure transducer, pressure fluctuations, which occur during displacement operation (swivel angle control), can have an unfavorable effect on the swivel angle control when the corrective feature described above becomes active. In this case, the swivel angle control can be stabilized by reducing or deactivating case drain oil compensation.

Reasons for pressure fluctuations can be the following:

- Process- or material-related
- Hydraulic motors with a small number of pistons
- Lifting cylinders with a low natural frequency
- Superimposed, closed position or velocity control loop

#### 4.11.3 Power limitation

In the case of electronic variants with extra function (feature "12" in the type code) "Power limitation adjustable on the pilot valve", a limiting value can be set by means of a potentiometer. If the optional function "power limitation via analog input" is selected, the limiting value is provided externally.

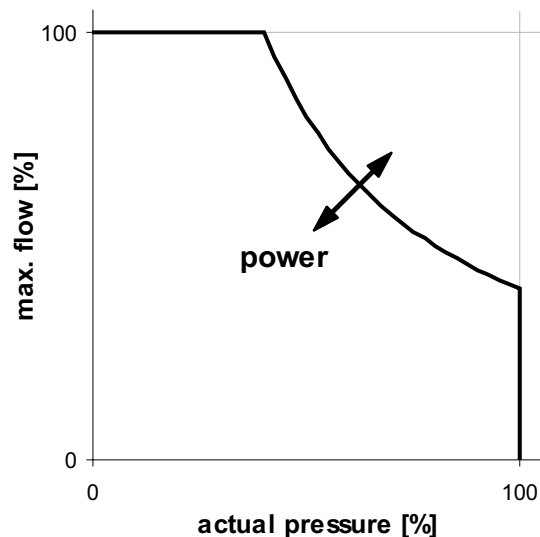

Fig. 13: Power limitation

When the power limiter cuts in, the operating variables (pressure and flow) adjust automatically according to the curve path of the set power hyperbola.

Product description

The adjustment of the power limitation is described in Chapter 7 “Commissioning” on page 51.

### 4.12 Master/slave operation

Circuitry of SY(H)DFEE for master/slave operation

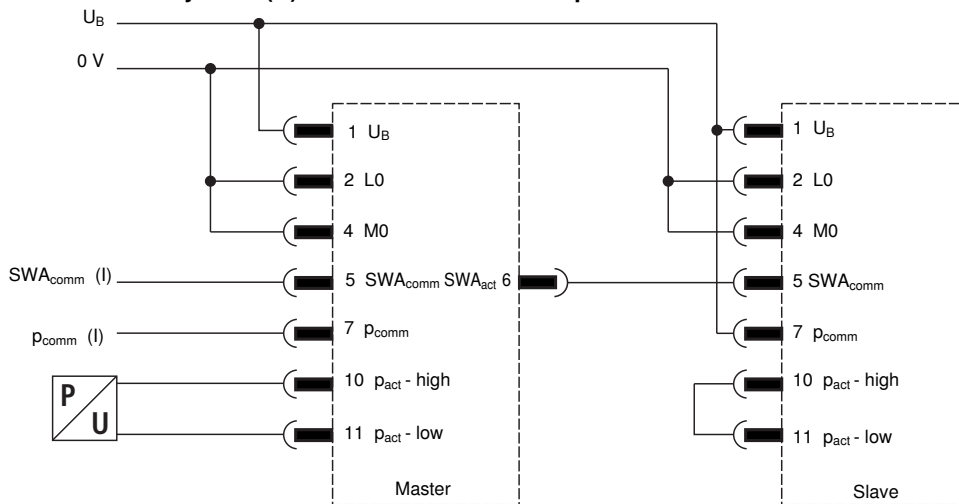

Fig. 14: Circuitry of SY(H)DFEE for master/slave operation

Theoretically, an optional number of SY(H)DFEE control systems can be hydraulically coupled to achieve greater flows.

In this case, it is just required to determine a master pump to which the pressure transducer, if provided, has to be connected.

The master controls both, pressure and swivel angle, in accordance with the externally provided command values and passes its actual swivel value (SWA<sub>act</sub>) on to the slave pumps as swivel angle command value (SWA<sub>comm</sub>). This ensures smooth and synchronous swiveling of the pumps.

Consequently, the slave pumps operate only under swivel angle control, which is the reason why in this operating mode no pressure transducer signal may be fed to their control electronics.

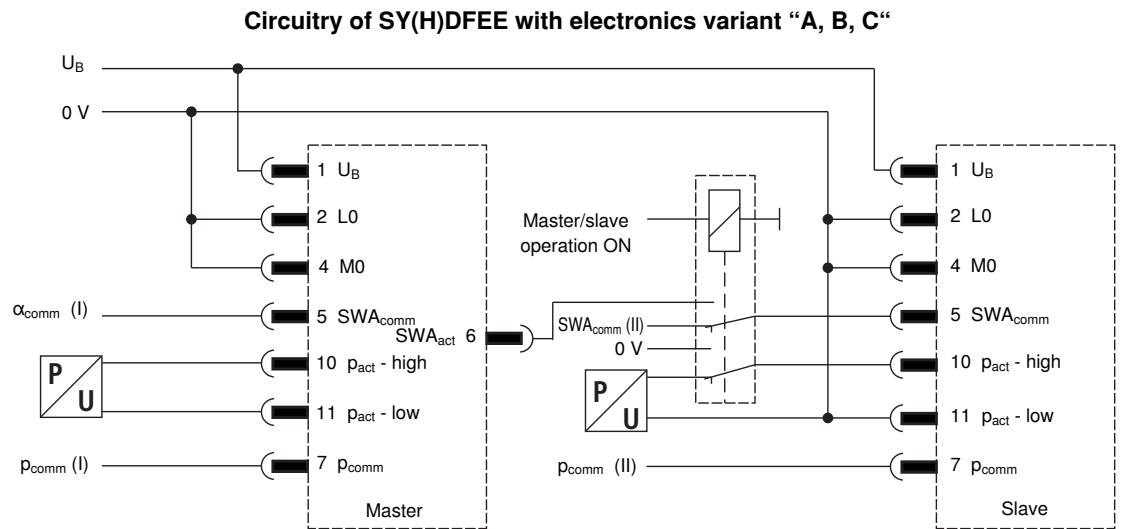

Fig. 15: Circuitry of SY(H)DFEE for master/slave and individual operation

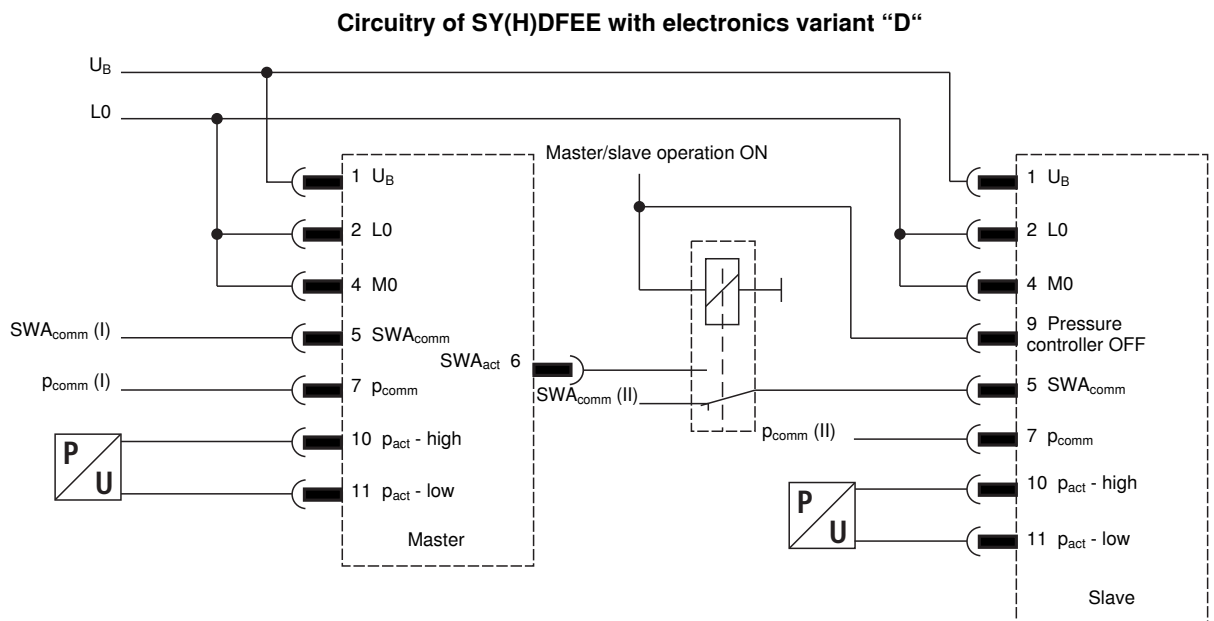

Fig. 16: Circuitry of SY(H)DFEE for master/slave operation and individual operation



## Notes:

- Select the electronics for the slave axis in the variant "pressure transducer with voltage input 0...10 V" ("SY(H)DFEE/...V...").
- The connection for the position transducer of the pumps is not drawn.
- The coupling element (relay, analog switch) can be optionally installed to control both pumps independently of one another. With the proposal shown here, both, swivel angle and pressure control, are possible with the slave pump.
- For the master/slave operating mode, the signal  $p_{comm}(II)$  must be set to maximum (+10 V... $U_B$ ).
- If closed-loop pressure control is to be possible also in the master/slave operating mode, only the pressure transducer of the master is evaluated

## Product description

for controlling purposes. If hydraulically separated operation should also be possible, a separate pressure transducer is required also for the slave.

- If the signal branch of the pressure transducer of the slave axis is not provided with a specific circuitry, its pressure controller could intervene into the swivel angle control in an undesirable manner, when the actual pressure value  $p_{act(II)}$  reaches values in the order of ca. 80 % or higher of the command value  $p_{comm(II)}$ . Care must be taken that the D controller parameter on the slave is not set higher than on the master. When electronics variant "D" is used, the pressure controller can be switched off via a switching input (pin 9). As a result, only the swivel angle controller is active - independently of  $p_{comm}$  or  $p_{act}$  (with "D", no control parameter changeover is provided).

## Changing over to master/slave operation

**Starting point** 0 V reference potentials of the PLC/command value source and M0/L0 of the SYDFEE electronics must be connected.

Operate both pumps until they reach the point shortly **before** they change over to closed-loop pressure control (low, identical pressure level) and are still hydraulically uncoupled from each other. Approximately identical actual swivel angle values would be optimal. Set the flow command value to a low value (e.g. 10 %).

When a pre-load valve is used, it should preferably be installed on the master pump.

**Changing over to master/slave operation** At low operating pressures, the flow command value, which has been previously provided by the control, is withdrawn from the slave pump via a changeover contact suitable for small signal voltages (or, alternatively, a wear-free analog switch), and the actual swivel angle value provided by the SY(H)DFEn electronics of the master pump is fed forward.

The pressure command value of the slave pump is set to 100 % (if required, via a second changeover contact or by means of software) in order that closed-loop pressure control of this unit is quasi switched off. With electronics "D": High signal at pin 9.

Now, the hydraulic short-circuit valve (connection of the previously separated pressure circuits) can be activated. A delayed activation of this valve may have to be adjusted depending on whether this would improve the system characteristics in the changeover process.

**Deactivating master/slave operation** In the master/slave operating mode it is also useful that the control keeps the two swivel angle command values for the master and the slave pump synchronized in order that striking differences in the signal level are prevented when the swivel angle command value source for the slave pump is changed (from actual swivel angle value of the master pump back to the control output).

The pressure command value of the slave pump should be set to the same level as that of the master pump before the slave pump is changed over to individual operation (jerk-free changeover).

**Connection of unused, electrical signal inputs** All the analog inputs that are not used, e.g. actual pressure value input in the case of flow control, must be connected to 0 Volt.

In contrast to this, differential amplifier inputs that are not used may also be short-circuited.

#### 4.12.1 Activation sequence of electronics/hydraulics

##### General

Due to various monitoring routines integrated in the electronic assemblies, error messages may be generated in the case of an unfavorable order of switching on. These error messages cause uncertainties, although they have no "real" cause of fault.

In principle, it is valid that all SY(H)DFEE control systems that are provided exclusively with internal pilot oil supply automatically swivel to the operationally safe zero stroke position in the event of a power failure. However, a precondition for zero stroke is a minimum pressure between 8 and 12 bar, which the pump has to build up as pilot pressure. This can always be ensured, when no oil can flow away from the pump output (e.g. actuator line hydraulically blocked).

Please observe the special case of suspended loads!

Observe the following activation sequence:

Analog electronics ON:	<ul style="list-style-type: none"> <li>• Voltage supply of the electronics</li> </ul>
SYDFEE:	<ul style="list-style-type: none"> <li>• Switch motor on and suppress error message until star/delta changeover takes place</li> <li>• Open check valve (if provided)</li> </ul>
OFF:	<ul style="list-style-type: none"> <li>• Command value provision: <math>SWA_{comm} = 5\%</math> and <math>p = 10\text{ bar}</math></li> <li>• Close check valve (if provided)</li> <li>• Suppress error message</li> <li>• Switch el. motor off</li> <li>• Switch voltage supply of electronics off</li> </ul>

#### 4.13 Identification of the product

The SY(H)DFEE control system can be identified with the help of the nameplate. The figure below shows the example of a SY2HDFEE nameplate

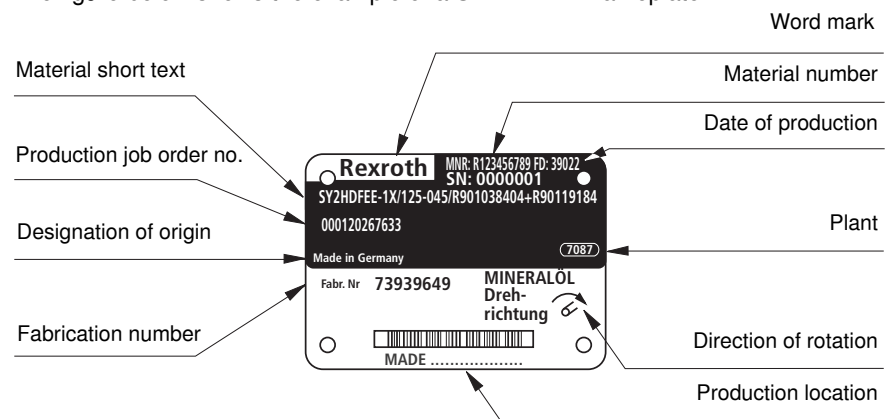

Fig. 17: Nameplate



For queries with regard to the pump combination you must have the material number and the fabrication number at hand.

## 5 Transport and storage

### 5.1 Transporting the SY(H)DFEE control system

**DANGER!**



**Risk of personal injury and damage to property!**

When transported improperly, the SY(H)DFEE control system can fall down and cause personal injury and/or damage to the control system, because parts may have, for example, sharp edges, be heavy, oily, loose or bulky. Parts of the SY(H)DFEE control system systems can be torn off or distorted.

- ▶ Ensure a stable position during transport to the place of installation.
- ▶ Wear personal protective equipment (such as gloves, safety shoes, protective goggles, working clothes, etc.)
- ▶ Observe national laws and regulations regarding safety at work and health protection and transport.

**CAUTION!**



**Risk of damage!**

Hitting or impulsive forces on the drive shaft or the pilot valve can damage the SY(H)DFEE control system.

- ▶ Do not hit the coupling or drive shaft of the axial piston unit.
- ▶ Do not set/place the axial piston unit on the drive shaft.
- ▶ Do not set/place the SY(H)DFEE control system on the pilot valve.
- ▶ Details on the permissible axial and radial forces on the shaft can be found in the data sheet.

SY(H)DFEE control systems can be transported using a fork lift truck or lifting gear.

- ▶ Make certain that the fork lift truck or lifting device has adequate lifting capacity.

**Dimensions and weights**

**Table 3: Dimensions and weights**

SYDFEE 2X / size			18	28	45	71	100	140
Weight	Pump without through-drive, incl. pilot valve	kg	14	17	23	35	47	62
	In addition, pre-load valve	kg	3,3	3,3	3,3	6,3	6,3	6,3
	In addition, with external actuating system supply	kg	2	2	2	2	2	2
SYDFEE 3X / size			71	100	140			
Weight	Pump without through-drive, incl. pilot valve	kg	49	71	75			
	In addition, pre-load valve	kg	6,3	6,3	6,3			
	In addition, with external actuating system supply	kg	2	2	2			
SYHDFEE 1X / size			125	180	250	355		
Weight	Pump without through-drive, incl. pilot valve	kg	100	115	197	220		

The dimensions vary depending on optional equipment. The values applicable to your SY(H)DFEE control system can be found on the installation drawing or in the data sheet of the relevant control system.

**Carrying the SY(H)DFEE control system**

SY(H)DFEE control systems of a low weight can be transported manually, if required (the weight for brief lifting should not exceed 15 kg for women and 25 for men).

**CAUTION!****Risk of health damage!**

Lifting heavy SY(H)DFEE control systems involves the risk of health damage.

- ▶ When transporting the SY(H)DFEE control system, apply suitable techniques for lifting, lowering and relocating or use suitable lifting gear.

**5.1.1 Transporting with lifting gear**

Please observe the following points for transporting:

- Properties of the load (e.g. weight, center of gravity, mounting and attachment points).
- Way of attaching or suspending the load
- Make sure that the load carrying capacity of the lifting gear is sufficient for transporting the SY(H)DFEE control system without any risks.
- Use textile lifting slings in accordance with DIN EN 1492-2.



For further information on transportation, please contact Bosch Rexroth.

For transporting, the SY(H)DFEE control system can be connected to a lifting device using a ring screw or a lifting strap.

**Transport with ring screw**

The drive shaft can be used to transport the SY(H)DFEE control system as long as only outward axial forces occur. Consequently, you can suspend the SY(H)DFEE from the drive shaft.

- ▶ To do this, screw a ring screw completely into the female thread on the drive shaft. The size of the thread is stated in the installation drawing.
- ▶ Make sure that each ring screw can bear the total weight of the SY(H)DFEE control system plus approx. 20 %.

You can lift the SY(H)DFEE control system without any risk of damage as shown in Fig. 18 using the ring screw screwed into the drive shaft.

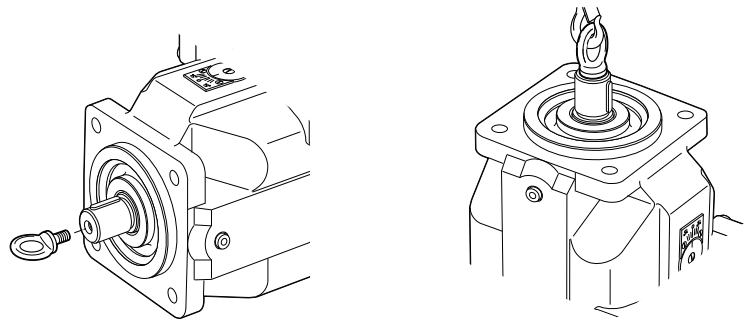

**Fig. 18: Fixing the ring screw**

**Transport with lifting strap**

- ▶ Place the lifting strap around the SY(H)DFEE control system in such a way that it passes over neither the attachment parts (e.g. valves) nor such that the SY(H)DFEE control system is hung from attachment parts (see Fig. 19).

## Transport and storage

**WARNING!****Risk of injury!**

During transport with a lifting device, the control system can fall out of the lifting strap and cause injuries.

- ▶ Hold the control system with your hands to prevent it from falling out of the lifting strap.
- ▶ Use the widest possible lifting strap.

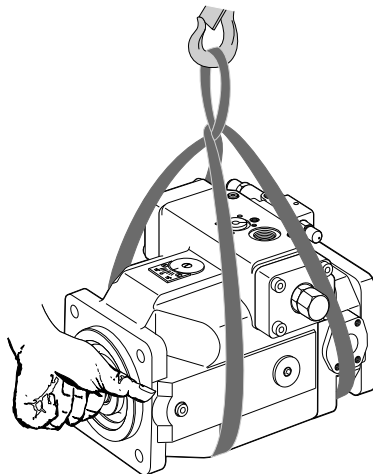

**Fig. 19: Transport with lifting strap**



Transport damage must be reported to your contact in the sales organization within one week. You can find the addresses of our sales locations on the Internet at:

<http://www.boschrexroth.com/adressen>

## 5.2 Storing the SY(H)DFEE control system

Some SY(H)DFEE control systems are shipped in an anti-corrosion foil (max. storage time: 12 months). Without anti-corrosion foil, corrosion protection is limited to transport (a few days). If these control systems are to be stored, then you must provide preservation like for storage after disassembly (see below).

For storing SY(H)DFEE control systems in an anti-corrosion foil, the following storage conditions apply:

### Requirements

- The storage rooms must be free from corrosive materials and gases.
  - The storage rooms must be dry.
  - The ideal temperature for storage lies between +5 °C and +20 °C.
  - Avoid intense lights.
  - Do not stack SY(H)DFEE control systems and store them shock-proof and slip-proof.
  - SY(H)DFEE control systems are very heavy (see table 3 "Dimensions and weights" on page 32). Also take account of the permissible useful loads of your storage system.
- ▶ Check the SY(H)DFEE control system monthly for proper storage.

Procedure after expiration of the maximum storage time:

1. Check the entire SY(H)DFEE control system for damage and corrosion prior to installation.

2. Check the SY(H)DFEE control system for proper function and leaks during a test run.
3. Replace the shaft seal ring when the storage time of 24 months is exceeded.



After expiration of the maximum storage time, we recommend that you have the SY(H)DFEE control system inspected by your responsible Rexroth Service partner.

Should you have questions regarding spare parts, contact your responsible Rexroth Service partner or the service department of the manufacturer's plant for the SY(H)DFEE control system, see Chapter 9.5 "Spare parts" on page 63 for further information.

#### After disassembly

If a dismantled SY(H)DFEE control system is to be stored, it must be preserved against corrosion for the duration of storage.



The following instructions only refer to SY(H)DFEE control systems, which are operated with a mineral-oil based hydraulic fluid. Other hydraulic fluids require preservation methods that are specifically tailored to them. In such a case, consult with the Rexroth Service (see Chapter 9.5 "Spare parts" on page 63 for address).

Rexroth recommends the following proceeding:

1. Clean the SY(H)DFEE control system, see also Chapter 9.1 "Cleaning and care", page 62.
2. Drain the SY(H)DFEE control system completely.
3. For storage times of more than 12 months: Wet the SY(H)DFEE control system internally with mineral oil by filling in about 100 ml of mineral oil.  
For storage time up to 24 months: Fill the SY(H)DFEE control system with anti-corrosion agent VCI 329 (20 ml).  
Filling via the case drain port.
4. Plug all ports air-tight.
5. Wet non-varnished external metal surfaces of the SY(H)DFEE control system with mineral oil.
6. Pack the SY(H)DFEE control system air-tight together with a desiccant in an anti-corrosion foil.
7. Protect the SY(H)DFE control system against impacts during storage. For further conditions, see "Requirements" in this chapter.

Always observe the general laws and regulations when handling water-endangering and harmful substances.

## 6 Installation

Before starting with the assembly and installation work, the following documents must be available:

- Hydraulic circuit diagram for the system (available from the system manufacturer)
- Data sheet of the SY(H)DFEE control system (contains the technical data)
- Order confirmation (contains the preset data of the SY(H)DFEE control system)

### 6.1 Unpacking

---

**CAUTION!****Risk of parts falling out!**

If the packaging is not opened correctly, parts may fall out and damage the parts or even result in injury.

- ▶ Place the packaging on a flat and solid surface.
- ▶ Only open the packaging from the top.

---

Some SY(H)DFEE control systems are delivered in an anti-corrosion foil made of polyethylene material.

- ▶ Dispose of the packaging according to the national regulations of your country.

### 6.2 Installation conditions

- The installation orientation and position of the SY(H)DFEE control system essentially determine the procedures during installation and commissioning (such as when filling the SY(H)DFEE control system).
- Note that you can expect certain installation positions to affect the control behavior. Because of gravity, dead weight and case pressure, minor characteristic curve offsets and actuating time changes may occur.
  - ▶ Adhere to all limits specified in the data sheet regarding temperature, viscosity, cleanliness of the hydraulic fluid.
  - ▶ Make certain that the case of the SY(H)DFEE control system is filled with hydraulic fluid during commissioning and operation. This is also to be observed following relatively long standstill periods as the SY(H)DFEE control system may empty via the hydraulic lines.
  - ▶ To achieve favorable noise values, decouple all connecting lines from all components that can vibrate (e.g. tank) using elastic elements.
  - ▶ Make certain that the suction line, case drain line, and return line flow into the tank below the minimum fluid level in all operational states.
  - ▶ Strictly observe extreme cleanliness. The SY(H)DFEE control system must be installed without any contamination. Contamination of the hydraulic fluid can significantly affect the service life of the SY(H)DFEE control system.
  - ▶ Do not use any cotton waste or linty cloths for cleaning.
  - ▶ Use suitable liquid detergents to remove lubricants and other difficult-to-remove contamination. Detergents must not penetrate the hydraulic system.

**CAUTION!****Risk of damage by air inclusions!**

An air pocket in the bearings will damage the SY(H)DFEE control system.

- ▶ Make certain that the pump case is completely filled with hydraulic fluid during commissioning and during operation with the “drive shaft upwards” installation position.
- ▶ During commissioning and during operation, the suction line must be filled with hydraulic fluid.

**CAUTION!****Risk of damage due to hydraulic fluid loss!**

With tank-top installation, the case interior may drain via the case drain line after longer standstill periods (air enters via the shaft seal ring) or via the service line (gap leakage). The bearings are thus insufficiently lubricated when the pump is restarted.

- ▶ Check the hydraulic fluid level in the case interior regularly; if necessary, recommission.

## 6.3 Installation positions and piping of SY(H)DFEE systems

### 6.3.1 General

The installation instructions are tailored to the use of the SY(H)DFEE control system. Adhering to these instructions is a decisive factor for the service life of the units.

The instructions refer to standard types and standard installation situations. Particular installation situations require additional measures to be taken on the unit, which are documented separately.

Generally, care must be taken that during commissioning and re-commissioning of a system or equipment, the entire case of the axial piston unit is filled with hydraulic fluid and remains filled during operation.

**CAUTION!****Risk of damage due to lack of hydraulic fluid!**

Commissioning or re-commissioning of the unit without or with insufficient hydraulic fluid in the case interior results in damage to or destruction of the rotary group.

- ▶ Make certain that the pump case is filled with hydraulic fluid. An optimum filling orientation is assigned to each type. Only this orientation allows complete filling of the case, which is the reason why this orientation must be adhered to during commissioning. For re-commissioning, this orientation should be complied with as far as possible.

In the following, we distinguish between the installation position (pump/motor in relation to tank) and the installation orientation (position of the pump/motor shaft end vertical, horizontal, etc.).

The following installation positions are permitted. The pipe routing shown represents the general routing.

**Installation position**

The following installation positions are possible (see Fig. 20):

- Pos. a): Pump/motor above the tank (above minimum oil level)
- Pos. b): Pump/motor next to or below the tank (below minimum oil level), with the upper edge of the case corresponding to the minimum oil level

**Installation**

- Pos. c): Pump/motor in the tank (below minimum oil level). SY(H)DFEE control systems cannot be installed in the tank. Use control system (SY(H)DFE1 for oil-immersed applications.

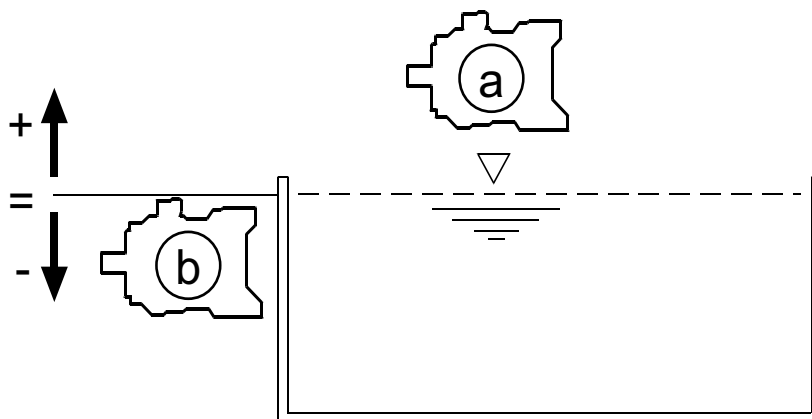

SYD\_015

**Fig. 20: Installation position**

**Installation orientation**

The following installation orientations are possible (see Fig. 21):

- Pos.1 horizontal: Shaft end horizontal
- Pos.2 vertical: Shaft end upwards
- Pos.3 vertical: Shaft end downwards

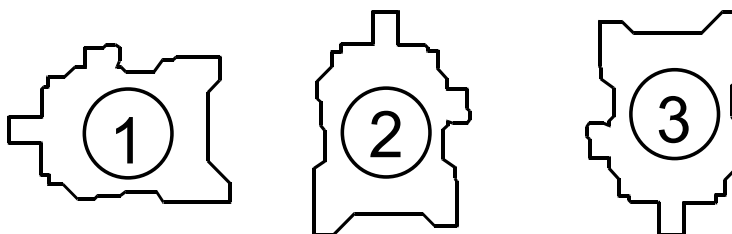

SYD\_016

**Fig. 21: Installation orientations**

**6.3.2 Piping**

The installation positions and installation orientations shown in Figs. 20 and 21 determine the installation of

- suction lines
- case drain lines
- bleed lines.

Make sure for all installation positions that always the higher of drain ports “L” or “L1” is piped. Moreover, the distance between the end of installed pipes and the minimum oil level must not be shorter than the specified minimum distance (immersion depth “E”).

**Special points**

When installing suction and drain lines, take care that the routing is straight, short and has as few bends as possible.

When the system is at rest, the lines drain automatically in the course of time due to the own weight of the hydraulic fluid.

Moreover, the different specific densities of hydraulic fluids must be taken into account, since fluids with a higher density are more difficult to aspire and also flow down more quickly. The limit speeds for hydraulic fluids with high density ( $\geq$  mineral oil 0.87 g/ml) are specified in data sheet RE 90223.

For pumps, a minimum suction pressure is prescribed for port "S" irrespective of installation positions and installation orientations:

minimum suction pressure  $\geq 0.8$  bar abs.

To establish the suction pressure (inlet pressure)  $p_{abs}$  in dependence on the displacement or speed, please observe the technical data given in data sheets RE 30030, 30630 and 30035.

### CAUTION!



### Damage to the SY(H)DFEE control systems!

Pressure values below the specified value can result in damage or destruction of the unit.

- For this reason, make sure that the pressure does not fall below the prescribed minimum value.

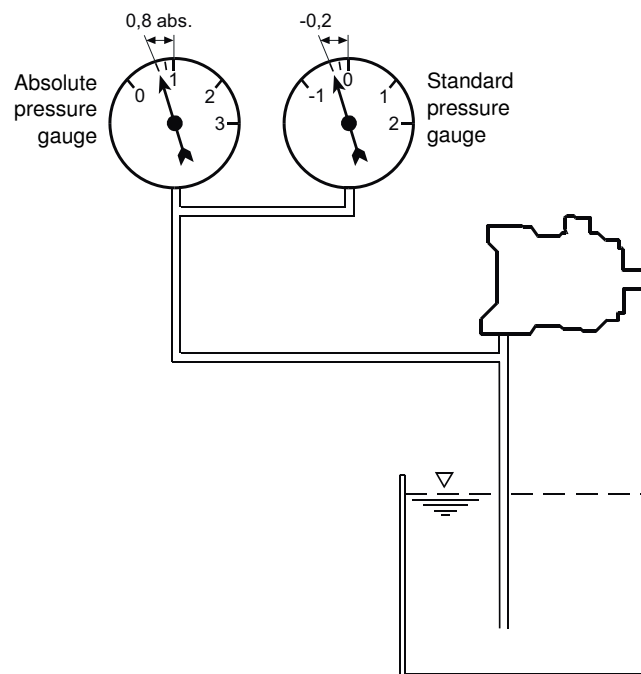

SYD 017

Fig. 22: Minimum suction pressure

### Case drain piping

Dynamic swiveling processes result in increased case pressures that are caused by the acceleration phase of the drain oil column. They occur within milliseconds and must not exceed 6 bar<sub>abs.</sub>. They are influenced by the inductive resistance of the case drain line ( $\Delta p_i = f(\text{diameter, length})$ ). Here, the flow resistance at the case drain fitting on the pump case plays a subordinate role.



### General notes

The  $\Delta p_i$  value can only be improved by a larger nominal width of the case drain line.

Generally, the following must be observed:

- Each pump should preferably be piped with a separate case drain line.

## Installation

- ▶ Direct the case drain fluid in the case chamber via the highest case drain port as short as possible (ca. 1 m) directly to the tank. Use a pipe size, which corresponds to the port.
- ▶ When the specified line lengths are exceeded we recommend that the nominal width be increased by one size per additional meter.
- ▶ The nominal width of the case drain line determined by the threaded connection on the pump case must not be reduced. Use "light series" pipes only.
- ▶ Do not use check valves in case drain lines.
- ▶ The case drain line should always enter the tank in the return flow chamber below the oil level. For tank designs without direct separation of the suction chamber, the drain line should be returned to the tank as far away as possible from the suction port.
- ▶ External influences of pressure, e.g. from manifold tank lines, on the pump drain port or the pump case are not permitted.

## 6.4 Installing the SY(H)DFEE control system

### DANGER!



#### Risk of injury through systems which were not shut down!

Working on running systems poses a danger to life and limb. The work steps described in this chapter must only be performed on systems which are at a standstill. Before beginning work:

- ▶ Make sure that the drive motor cannot be switched on.
- ▶ Make sure that all power-transmitting components and connections (electric, pneumatic, hydraulic) are switched off according to the manufacturer's instructions and are secured against being switched on again. If possible, remove the main fuse of the system.
- ▶ Ensure that the system is completely hydraulically relieved and depressurized. Please follow the system manufacturer's instructions.
- ▶ Only qualified personnel (see Chapter 2.3 "Personnel qualifications" on page 8) are authorized to install the SY(H)DFEE control system.

### 6.4.1 Preparation

1. Check the delivery contents for completeness and transport damage.
2. Compare the material number and designation (ordering code) with the details on the order confirmation.



If the material number for the SY(H)DFEE control system does not correspond to the one on the order confirmation, contact Rexroth Service for clarification, see Chapter "9.5 Spare parts" on page 63 for address.

3. Before installing the SY(H)DFEE control system, completely empty it to prevent mixing with the hydraulic fluid used in the system.
4. Check the direction of rotation of the SY(H)DFEE control system (on the nameplate) and make sure that this corresponds to the direction of rotation of the motor.



The direction of rotation as specified on the nameplate determines the direction of rotation of the SY(H)DFEE control system as viewed on the drive shaft. For information on the direction of rotation of the motor, please refer to the motor manufacturer's operating instructions.

**CAUTION!****Damage caused by missing seals and plugs!**

Fluids and foreign particles can get into the product and destroy it.

- ▶ Before starting the installation make sure that all seals and plugs of the connections are tight.

**CAUTION!****Risk caused by incorrect mounting of the SY(H)DFEE control system!**

An improperly mounted SY(H)DFEE control system can move in an uncontrolled manner and damage other system parts.

- ▶ Make sure that the SY(H)DFEE control system is properly mounted.

**6.4.2 Dimensions**

The data sheet contains the dimensions for all connections to the SY(H)DFEE control system. Also observe the instructions provided by the manufacturers of the other components when selecting the required tools.

**6.4.3 General notes**

When installing and uninstalling the SY(H)DFEE control system, observe the following general notes and instructions for action:

- ▶ Mount the SY(H)DFEE control system so that the expected forces and torques can be transmitted without any risks.
- ▶ The permissible axial and radial loading of the drive shaft, the permissible torsional vibration, the optimum direction of load force, as well as the limit speeds can be found in the data sheet.

**CAUTION!****Risk of damage!**

Hitting or impulsive forces on the drive shaft can damage the SY(H)DFEE control system.

- ▶ Do not hit the coupling or drive shaft of the SY(H)DFEE control system.
- ▶ Do not set/place the SY(H)DFEE control system on the drive shaft.
- ▶ Details on the permissible axial and radial forces can be found in the data sheet.

**6.4.4 Installation with coupling**

The SY(H)DFEE control system is usually flange-mounted to a motor with a coupling. If you plan to install the unit otherwise, please consult us.

How to install the axial piston unit with a coupling is described in detail in the following:

1. Mount the relevant coupling half onto the drive shaft of the SY(H)DFEE control system according to the instructions of the coupling manufacturer.

## Installation



The drive shaft end of the SY(H)DFEE control system is provided with a threaded bore. Use this threaded bore to pull the coupling element onto the drive shaft. Refer to the installation drawing for the dimensions of the threaded bore.

2. Make sure that the installation location is clean and free from dirt and foreign particles.
3. Fix the coupling hub on the drive shaft or ensure permanent lubrication of the drive shaft. This prevents the formation of frictional corrosion and associated wear.
4. Transport the SY(H)DFEE control system to the installation location.
5. Mount the coupling to the drive in accordance with the instructions of the coupling manufacturer.



The SY(H)DFEE control system must not be tightened down until the coupling has been correctly assembled.

6. Mount the SY(H)DFEE control system at the installation location.
7. If necessary, details on the required tools and tightening torques for the mounting screws are available from the machine or system manufacturer.
  - For bell housing installation, check the coupling axial play through the bell window according to the instructions of the machine or system manufacturer.
  - For flange installation, align the support of the SY(H)DFEE control system with the drive.
8. When using flexible couplings, check that the drive is free of resonance after having completed the installation.

#### 6.4.5 Completing the installation

1. Remove transport screws, if fitted.
2. Remove the transport protection.  
The axial piston unit of the SY(H)DFEE control system was delivered with protective covers and plastic plugs or plug screws. These must be removed before connecting the system. Use appropriate tools.
3. Make certain that the sealing and functional surfaces are not damaged.

---

#### CAUTION!



#### Risk of personal injury and damage to equipment!

Operating the SY(H)DFEE control system with plastic plugs can cause injuries or damage to the SY(H)DFEE control system.

- ▶ Before commissioning, remove all plastic plugs and replace them with suitable, pressure-proof metal plug screws, because plastic plugs are not pressure-proof.



Setscrews, if provided, are protected against unauthorized resetting by means of protective caps. Removing protective caps will void the warranty. If you need to modify the setting, please contact the responsible Rexroth Service (for address, see Chapter 9.5 "Spare parts" on page 63).

For the variant with through-drive, mount the auxiliary pump in accordance with the instructions of the pump manufacturer.

## 6.5 Connecting the SY(H)DFEE control system hydraulically

The machine or system manufacturer is responsible for dimensioning the lines. The SY(H)DFEE control system must be connected to the rest of the hydraulic system in accordance with the hydraulic circuit diagram of the machine or system manufacturer.

### CAUTION!



#### Damage to the SY(H)DFEE control system!

Hydraulic pipes and hoses, which are installed under mechanical stress, generate additional forces during operation, which reduces the service life of the SY(H)DFEE control system and the machine or system as a whole.

- ▶ Install pipes and hoses stress-free.

### CAUTION!



#### Risk of damage!

Generally, a minimum permissible suction pressure at port "S" is specified for SY(H)DFEE control systems in all installation positions. If the pressure at port "S" drops below the specified values, damage may occur which may lead to the destruction of the SY(H)DFEE control system.

- ▶ Make certain that the necessary suction pressure is achieved. This is influenced by:
  - appropriate piping of the suction cross-sections
  - appropriate pipe diameters
  - appropriate position of the tank
  - appropriate viscosity of the hydraulic fluid



Connect only hydraulic lines to the service and function ports.

### CAUTION!



#### Wear and malfunction!

The cleanliness of the hydraulic fluid has a considerable impact on the cleanliness and service life of the hydraulic system. Any contamination of the hydraulic fluid leads to wear and malfunctions. In particular, contaminants like e.g. welding beads or metal cuttings in the hydraulic lines may damage the SY(H)DFEE control system.

- ▶ Ensure utmost cleanliness.
- ▶ The SY(H)DFEE control system must be installed in a clean condition.
- ▶ Make sure that all ports, hydraulic lines and add-on units (e.g. measuring devices) are clean.
- ▶ Make sure that no contaminants can enter the system when you close the ports.
- ▶ Make sure that no detergents enter the hydraulic system.
- ▶ Do not use any cotton waste or linty cloths for cleaning.
- ▶ Never use hemp as sealant.

#### Notes on routing of lines

Observe the following notes when routing the suction, pressure and case drain lines.

- ▶ See to it that the suction line (pipe or hose) is as short and straight as possible.
- ▶ The line cross-section of the suction line is to be dimensioned so that the pressure in the suction port does not fall below the minimum permissible value and the maximum permissible pressure is not exceeded.
- ▶ Observe air tightness of the junctions and pressure resistance of the hose, also with respect to the external air pressure.

Installation

- ▶ In conjunction with the pressure lines, make certain that the pipes, hoses and connecting elements are approved for the operating pressure range.
- ▶ Always route the case drain lines so that the housing is constantly filled with hydraulic fluid and ensure that no air gets through the shaft seal ring even during extended standstill periods. The pressure inside the case must not exceed the limit values specified for the SY(H)DFEE control system in the data sheet under any operating conditions. The case drain line in the tank must in any case end up below the minimum fluid level (see Chapter 6.3 "Installation positions" on page 37).



The ports and mounting threads are designed for the operating pressures specified in the data sheet. The machine or system manufacturer must ensure that the connecting elements and lines comply with the specified operating conditions (pressure, flow, hydraulic fluid, temperature) with the necessary safety factors.

The pressure port of the SYDFEE control system of size 71 is provided with threads for two standard flange patterns:

SAE 1" (dot-and-dashed line) for pressures above 250 bar and

SAE 1 1/4" (dotted line) for pressures up to 250 bar.

Because standard flanges according to SAE 1 1/4" are permitted up to 250 bar only, the porting pattern to SAE 1" must be used in the case of operating pressures higher than 250 bar.

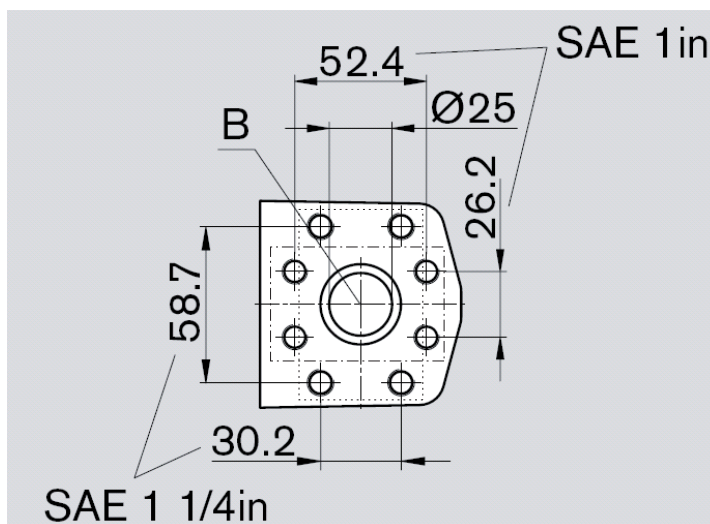

Fig. 23: Flange pattern

**Procedure** To connect the SY(H)DFEE control system to the hydraulic system:

1. Remove the plug screws from the ports that are to be connected according to the hydraulic circuit diagram.
2. Use only clean hydraulic lines.
3. Connect the lines according to the hydraulic circuit diagram.  
Either pipes or hoses must be connected to all ports according to the installation drawing and machine or system circuit diagram or the ports plugged using suitable plug screws.



The installation drawing contains the dimensions of all connections and ports on the SY(H)DFEE control system. Also observe the instructions provided by the manufacturers of the other hydraulic components when selecting the required tools.

## 4. Make sure

- that the cap nuts are correctly tightened on the fittings and flanges (observe tightening torques!). Mark all checked fittings using e.g. a permanent marker,
- that the pipes and hose lines and every combination of connecting pieces, couplings or connecting points with hoses or pipes have been inspected by a technically qualified person for their safe working condition.

**Tightening torques**

The tightening torques for the SY(H)DFEE control system are listed in the following table:

- Threaded hole in the axial piston unit:  
The maximum permissible tightening torques  $M_{Gmax}$  are the maximum values of the threaded holes and must not be exceeded.
- Fittings:  
Observe the manufacturer's instructions regarding tightening torques for the fittings used.
- Mounting screws:  
For mounting screws according to DIN 13/ISO 68, we recommend checking the tightening torque in each individual case as per VDI 2230.
- Plug screws:  
For the metal plug screws that come with the SY(H)DFEE control system, the required tightening torques of plug screws  $M_V$  apply.

**Risk of mix-ups with threaded connections**

SY(H)DFEE control systems are used in applications with metric as well as with imperial systems of units.

Both, the system of units as well as the size of threaded hole and threaded plug (e.g. plug screw) must match.

Since the systems cannot be distinguished visually, there is a risk of mixing up.

**WARNING!****Risk of personal injury and damage to property!**

If a threaded plug is used that differs from the threaded hole in terms of unit system and size and is pressurized, the threaded plug may loosen itself or even be ejected from the hole in a projectile-like manner. This can result in serious injury and damage to equipment. Hydraulic fluid can be discharged from this leakage point.

- ▶ Use the drawings (installation drawing/data sheet) to determine the required threaded plug for each fitting.
- ▶ Make certain that there are no mix-ups when assembling valves, mounting screws and plug screws.
- ▶ For all threaded holes, use a threaded plug from the same system of units and of the correct size.

Installation

Table 4: Tightening torques of threaded holes and plug screws

Thread size of ports		Max. permissible tightening torque of threaded holes $M_{Gmax}$	Required tightening torques for plug screws $M_V$	A/F hexagon socket
M10x1	DIN 3852	30 Nm	12 Nm	5 mm
M12x1,5	DIN 3852	50 Nm	25 Nm	6 mm
M14x1,5	DIN 3852	80 Nm	35 Nm	6 mm
M16x1,5	DIN 3852	100 Nm	50 Nm	8 mm
M18x1,5	DIN 3852	140 Nm	60 Nm	8 mm
M22x1,5	DIN 3852	210 Nm	80 Nm	10 mm
M26x1,5	DIN 3852	230 Nm	120 Nm	12 mm
M27x2	DIN 3852	330 Nm	135 Nm	12 mm
M33x2	DIN 3852	540 Nm	225 Nm	17 mm
M42x2	DIN 3852	720 Nm	360 Nm	22 mm
5/16-24 UNF-2B	ISO 11926	10 Nm	7 Nm	1/8 in
3/8-24 UNF-2B	ISO 11926	20 Nm	7 Nm	5/32 in
7/16-20 UNF-2B	ISO 11926	40 Nm	15 Nm	3/16 in
9/16-18 UNF-2B	ISO 11926	80 Nm	25 Nm	1/4 in
3/4-16 UNF-2B	ISO 11926	160 Nm	62 Nm	5/16 in
7/8-14 UNF-2B	ISO 11926	240 Nm	127 Nm	3/8 in
1 1/16-12 UN-2B	ISO 11926	360 Nm	147 Nm	9/16 in
1 5/16-12 UN-2B	ISO 11926	540 Nm	198 Nm	5/8 in
1 5/8-12 UN-2B	ISO 11926	960 Nm	320 Nm	3/4 in
1 7/8-12 UN-2B	ISO 11926	1200 Nm	390 Nm	3/4 in

- For the tightening torques for spare parts, please refer to the data sheet.

### 6.6 Connecting the SY(H)DFEE control system electrically

The machine or system manufacturer is responsible for the layout of the electrical control.

For electrically controlled SY(H)DFEE control systems, the electrical control must be connected according to the circuit diagram of the machine or system manufacturer.

**CAUTION!**



**Risk of injury due to live installation!  
Plugging and unplugging plug-in connectors under voltage destroys the SY(H)DFEE control system!**

If you do not switch off the power supply before you start the installation, you may injure yourself, destroy the product or damage system components.

- ▶ Always de-energize the relevant system part before you install the product or plug or unplug plug-in connectors.

1. Disconnect the relevant system part from the power supply.
2. Connect the SY(H)DFEE control system electrically (24 V).

**CAUTION!**



**Risk of short-circuit!**

Fluid can enter the product and cause a short-circuit.

- ▶ Do not install the SY(H)DFEE control system below the fluid level in a tank (in-tank installation).

### 6.6.1 Cabling of electronic components



Generally, the following is valid:

- Keep the number of intermediate terminals to a minimum.
- The arrangement of electromagnetic sources of interference in the direct vicinity of the pilot valve is not permitted.
- Installing power cables in the vicinity of the pilot valve is not permitted.
- Due to the use in a hydraulic environment, use only cable material that is specified as “oil-proof”. Otherwise, possible hardening of the cable jacket could lead to embrittlement and thus to breaking of individual wires.
- Select only cables that have the actually required number of wires (avoid superfluous wires).
- Cables for command values and actual values should be as short as possible.
- The signal cable to the pilot valve must in any case be shielded. The cable shield must be connected to ground on one end in the control cabinet.
- Strip the shield as short as possible and connect it in accordance with the data given in the RE data sheets.
- The contacts on the mating connector must not be exposed to mechanical stress. This can lead to a defective connection between the mating connector and the plug-in connector.

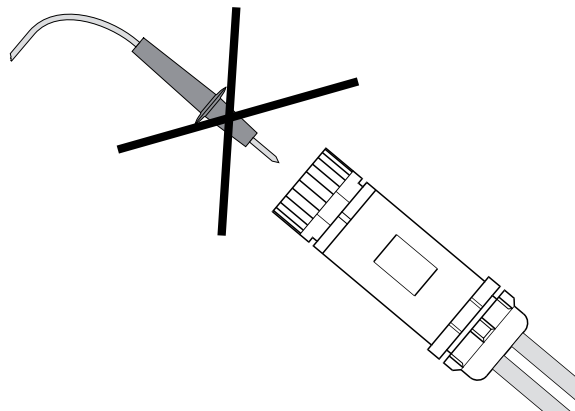

**Fig. 24: Protection of contacts**

Due to the fact that the control electronics is integrated in the valve housing in the factory, no additional cabling is required for the position transducer systems of the pump and the valve.

Cabling of the control system is therefore restricted to the connection of the 12-pin central connector of the integrated electronics to the customer's control and the pressure sensor, if provided.

For this connection, ready-to-connect and standardized cable kits are available in different lengths. On request, the 12-pin mating connector can be supplied separately for individual designs.

The HM16-1X/C13 pressure transducer is fitted with a ready-to-connect, standardized connection cable for direct connection to the VT-DFPE-x-2X/...F... electronics.

### 6.6.2 Power supply of the VT-DFPE pilot valve

The pilot valve VT-DFP is supplied with 24 V DC voltage. If this voltage supply is not provided on the part of the system, power supply unit VT 19 085 (NE32) according to RE 29929 can be used. The 24 V supply of the power supply unit is to be connected to connections 1 (+24 V) and 2 (L0) of the mating connector.

## Installation

In the case of the connection cable optionally available, this refers to the 2 black wires of the 3-pin cables with a cross-section of 1 mm<sup>2</sup>. Connect the wire marked with "1" to +24 V and the wire marked with "2" to L0 (ground). Connect the yellow/green wire to ground.

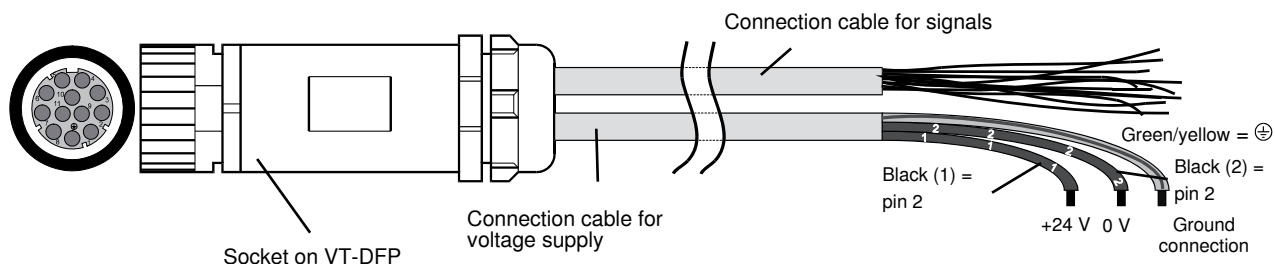

**Fig. 25: Connection of power supply**

### Recommendation:

The voltage supply for the VT-DFP.. pilot valve should be protected with a 1.6 A/ slow-blowing fuse on the system side.



The pilot valve is not provided with an enable input to block the function of the valve.

In the case of a fault, the pilot valve should be de-energized. Any further safety-relevant interventions must be made by the higher-level control (e.g. drive motor OFF, check valves closed, ...).

### 6.6.3 Selection, place of installation and mounting orientation of the pressure transducer

#### Selection of the pressure transducers

To reduce the number of variants, only pressure rating "315 bar" is given in the ordering code of the SY(H)DFEE control systems. If required, other pressure ratings can be combined (with the correct selection of the relevant electrical interface!). Such pressure transducers must, however, be ordered separately for the SY(H)DFEE control system.

In terms of signals, the sensors have to be distinguished as follows

- Sensors with current interface
- Sensors with voltage interface.

Here, the usual signal limits are between 0...20 mA or 0...10 V, respectively.

Within these limits, there are further modifications that depend on further options, such as monitoring for cable break.

From a technical point of view, the efficiency of the pressure transducer must be adapted to the SY(H)DFEE system in order that the best possible results can be obtained with regard to accuracy, dynamics and repeatability.

The pressure transducers recommended by us are listed in the RE data sheets of the relevant SY(H)DFEE system.

- Our pressure transducer model "HM12" with current interface (4 – 20 mA) is provided with a 2-conductor connection and allows the fail-safe transmission of signals – even over greater distances. Further pick-offs can be looped in taking into account the relevant input resistances.

- Our pressure transducer model "HM13" with voltage interface (0...10 V) has a 3-conductor connection and an integrated DC/DC converter, which effectively rules out disturbances on the analog signal caused by the voltage supply.
- The "HM16-1X/C13" pressure transducer has a voltage interface (0.5...5 V) with a ready-to-connect, standardized connection cable for direct connection to the VT-DFPE-x-2X/...F... electronics.

**CAUTION!****Uncontrolled increase in pressure!**

If no pressure signal is available, the control electronics can no longer recognize the pressure. This can result in an uncontrolled increase in pressure.

- ▶ The pressure transducer must be wired so that it cannot be short-circuited.

**Place of installation of the pressure transducer**

Favorable places of installation of pressure transducers turned out to be not in the direct vicinity of the pump, but, for example, downstream of the (flexible) pressure hose:

- Always between pump and check valve (if fitted)
- Do not use minimess lines



The installation in the pump case or in port "MP1" of the SYDZ pre-load valve is, due to more stringent demands made on signal processing (pressure pulsation), approved only for the combination of "SYDFEE-2X" and "HM16-1X/C13", since these control electronics allow a corresponding adjustment for this or are modified accordingly.

**Mounting orientation of the pressure transducer**

We recommend suspended mounting of the pressure transducer so that bleeding problems (and hence control oscillations) can be ruled out right from the start.

If, due to the installation orientation of the pump, a pressure transducer must be installed "vertically" directly in the pump or in the pre-load valve, we recommend another place of installation for the pressure transducer.

**Voltage supply and connection of the pressure transducer**

Pressure transducers for direct connection to valves with integrated electronics. It is optionally possible to connect pressure transducers of type HM16-1X/C13 directly to the electronics integrated in the valve using an M12 plug-in connector. For this variant, feature 14 in the type code is "F". Example: SYDFE-2X/018R-PPA12N00-0000-A0AOF<sub>L</sub>1. Since both, cabling and voltage supply, are fixed in this case, these points do not require particular attention.

An additional connection of the actual pressure value input via the 12-pin central connection is not permitted!

A precondition for the direct electrical connection of this special pressure transducer model is, however, the selection of valve variant VT-DFPE-x-2X provided for this purpose that must be selected with order option "F" in the type code.

The operation of the SYDFEE-2X control system with the HM16-1X/C13 pressure transducer mounted directly on the pump is only permitted in conjunction with the use of special electronics with reduced P-gain.

Installation

**HM12** Pressure transducers of type HM12-1X are provided with a 2-wire current interface and can be connected to the pilot valve using the central plug-in connection as shown on the figure below.

The voltage supply for the pressure transducer must be provided in accordance with the specification.

For more details about the pressure transducers HM12 and HM13, see RE 29933.

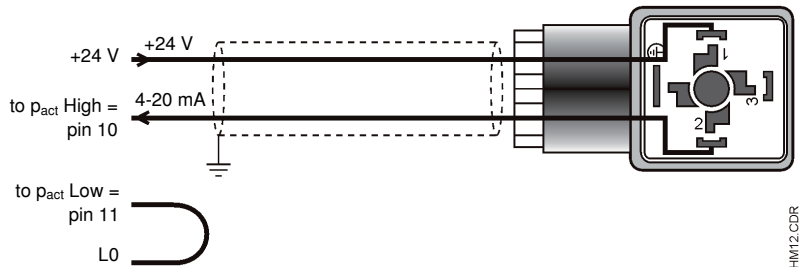
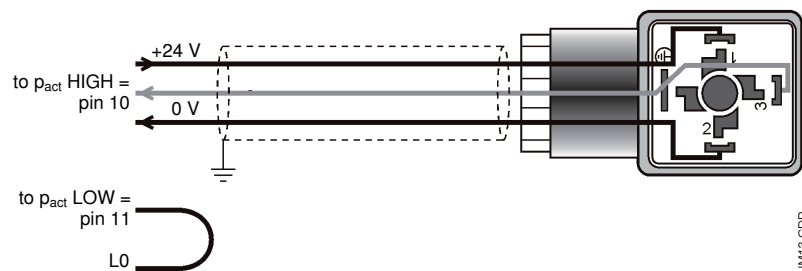

**Fig. 26: Connections of HM12**

**HM13** Pressure transducers of type HM13 are provided with a voltage output of 0... +10 V as actual pressure value signal and can be connected to the pilot valve using the central plug as shown on the figure below.

The voltage supply for the pressure transducer must be provided in accordance with the specification.

For more details about the pressure transducers HM12 and HM13, see RE 29933.



**Fig. 27: Connections of HM13**

## 7 Commissioning

**WARNING!****Danger while working in the danger zone of a machine or system!**

It is not permissible to work in the danger zone of a machine or system.

- ▶ The machine or system may only be operated if safe working is ensured.
- ▶ Pay attention to and eliminate potential danger sources before commissioning the machine or system.
- ▶ Nobody may stand in the danger zone of the machine or system.
- ▶ The emergency stop button for the machine or system must be within the operator's reach.
- ▶ Always strictly observe the instructions of the machine or system manufacturer during commissioning.

**CAUTION!****Risk of personal injury and damage to property!**

Commissioning of the SY(H)DFEE control system requires basic mechanical, hydraulic and electrical knowledge.

- ▶ Only qualified personnel (see Chapter 2.3 "Personnel qualifications" on page 8) are authorized to commission the SY(H)DFEE control system.

**WARNING!****Risk of toxication and injury!**

Contact with hydraulic fluids may damage your health (e.g. eye injuries, skin damage, toxication upon inhalation).

- ▶ Always check the lines for wear and damage before each commissioning.
- ▶ While performing these checks, wear safety gloves, safety glasses and suitable working clothes.
- ▶ If hydraulic fluid should, nevertheless, come into contact with your eyes or penetrate your skin, consult a doctor immediately.
- ▶ When working with hydraulic fluids, strictly observe the safety instructions provided by the hydraulic fluid manufacturer.

**WARNING!****Fire hazard!**

Hydraulic fluid is easily flammable.

- ▶ Keep open flames and ignition sources from the SY(H)DFEE control system.

**CAUTION!****Missing seals and connections lead to non-compliance with the protection class!**

Fluids and contaminants may penetrate and damage the product.

- ▶ Prior to assembly, make sure that all seals and plug-in connections are tight.

## Commissioning

## 7.1 First commissioning

**CAUTION!**

**Risk of damage to the product!**

Any contamination of the hydraulic fluid leads to wear and malfunction. In particular, contaminants like e.g. welding beads or metal cuttings in the hydraulic lines may damage the SY(H)DFEE control system.

- ▶ Ensure utmost cleanliness during commissioning.
- ▶ Make sure that no contaminants penetrate when closing the measuring ports.

**CAUTION!**

**Risk of damage to the product!**

If you commission the SY(H)DFEE control system without or with insufficient hydraulic fluid, the control system is damaged immediately or even destroyed.

- ▶ When commissioning or recommissioning a machine or system, make sure that the case interior and the suction and service lines of the SY(H)DFEE control system are filled with hydraulic fluid and remain filled during operation.



When commissioning the SY(H)DFEE control system, observe the basic safety instructions and intended use provided in Chapter 2 "General safety instructions" on page 7.

### 7.1.1 Filling the SY(H)DFEE control system

You will require an approved hydraulic fluid:

The machine or system manufacturer can provide you with precise data of the hydraulic fluid. Details on minimum requirements for mineral-oil based hydraulic fluids or HFC hydraulic fluids (only for SYHDFEE with option "F") are available in the Rexroth publications RE 92053 and RE 90223, respectively.

To ensure the functional reliability of the SY(H)DFEE control system, the hydraulic fluid must comply at least with cleanliness class 18/16/13 according to ISO 4406 for the hydraulic fluid for particle sizes 4/6/14  $\mu\text{m}$ . For permissible temperatures, see Chapter 4.7 "Notes on the selection of hydraulic fluids" on page 23.

**CAUTION!**

**Risk of damage to the product!**

An air pocket in the bearings will damage the SY(H)DFEE control system.

- ▶ In the case of installation position "drive shaft upwards", make certain that the pump case is completely filled with hydraulic fluid during commissioning and during operation.
- ▶ Check the hydraulic fluid level in the case interior regularly; if necessary, recommission. With tank-top installation, the case interior may drain via the case drain line after longer standstill periods (air enters via the shaft seal ring) or via the service line (gap leakage). The bearings are thus insufficiently lubricated when the pump is restarted.
- ▶ Make certain that the suction line is always filled with hydraulic fluid during commissioning and operation.



The SY(H)DFEE control system should be filled using a filling and filtration unit (10  $\mu\text{m}$  filtration rating). The control system must not be powered when being filled.

**CAUTION!****Danger of environmental pollution!**

The discharge or spillage of hydraulic fluid while filling the SY(H)DFEE control system can lead to environmental pollution and contamination of the groundwater.

- ▶ When filling and changing the hydraulic fluid, always place a catch pan under the SY(H)DFEE control system.
- ▶ Observe the information in the safety data sheet for the hydraulic fluid and the specifications provided by the system manufacturer.

1. Fill and air bleed the SY(H)DFEE control system via the appropriate ports, see Chapter 6.3 "Installation position" on page 37. The hydraulic lines of the system must also be filled.
2. Test the direction of rotation of the motor. To do this, rotate the motor briefly at the lowest rotational speed (inching). Make sure that the direction of rotation of the axial piston unit corresponds to the indication on the nameplate, see also Chapter 4.12 "Product identification", Fig. 17: Nameplate on page 31.
3. Operate the SY(H)DFEE control system at low speed (inching) until the pump system is completely filled and bled. For checking purposes, drain the hydraulic fluid at the case drain port and wait until it drains without bubbles.
4. Make certain that all ports are either connected to pipes or plugged according to the general circuit diagram.

**7.1.2 Performing a flushing cycle**

To remove foreign particles from the system, perform a flushing run for the entire system.



Flushing is to be carried out with an additional flushing power unit. Observe the instructions of the flushing unit manufacturer for the detailed procedure for carrying out the flushing cycle.

**7.1.3 Switching on the supply voltage for the electronics**

The activation sequence for electronics/hydraulics is described in section 4.12.1 "Activation sequence of electronics/hydraulics" on page 30.

At this point, the pump drive motor should be switched off. When switching on the power supply for the first time the command values for the electronics should be provided as follows.

Pressure command value ( $p_{comm}$ )	=	0.1 V
Flow command value ( $\alpha_{comm}$ )	=	10 V

After having switched on the power supply (motor is still switched off!), you should check the following points:

1. The fault signal output ERROR (pin 3) is in state "HIGH" (=24 V / reference L0).
2. The swivel angle  $SWA_{act}$  (pin 6) of the pump is within the range of +10 V  $\pm$ 0.3 V (positive stop / reference M0 = pin 4).

If this state is not reached, a fault must have occurred.

The following faults are conceivable:

- Power supply not available
  - Check power supply at the central plug-in connector of the electronics.
- Fault in the pressure measuring branch
  - Measure the actual pressure value  $p_{act}$  (pin 8) (must be 0 V). In the case of a negative voltage of about -0.5 V or less, a cable break message is

## Commissioning

generated. The output signal of the pressure transducer must be compatible with the type of the control electronics (current, voltage, zero point).

- Fault in the swivel angle measuring branch
  - Measure the actual swivel angle value  $SWA_{act}$  (pin 6). In the case of deviations from value  $+10\text{ V} \pm 250\text{ mV}$ , inspect the cable connection.

Further explanations on the analysis of faults can be found in Chapter 14. "Troubleshooting" on page 70.

#### 7.1.4 Switching on the drive motor of the pump

1. Close all directional valves.
2. Before cutting in the motor, apply the following command values to the pilot valve:

Pressure command value ( $p_{comm}$ )	=	1.0 V $\triangleq$ 31.5 bar
Flow command value ( $SWA_{comm}$ )	=	2.0 V $\triangleq$ 20 %

These values are valid when you use our standard pressure transducer with a measuring range of 0...315 bar.

In this state the VT-DFP pilot valve signals a "fault" (excessive control error). When the control system works correctly, this fault signal disappears after the motor has been switched on (control deviation now equal to zero).



The hydraulic fluid should have reached operating temperature before you continue with further commissioning.  
For initial commissioning, limit the pressure to max. 50 bar.

#### 7.1.5 Bleeding the pre-load valve

When a pump unit is operated with a pre-load valve, this valve must be air-bled for the initial start-up, if the pump does not deliver and aspire oil. Bleeding is not required, when the pump displaces oil. Bleed the pump while the system is running at low operating pressure. To this end, loosen the screw (see figure below) by a maximum of 2 turns and wait until bubble-free oil flows out. Then, re-tighten the screw.

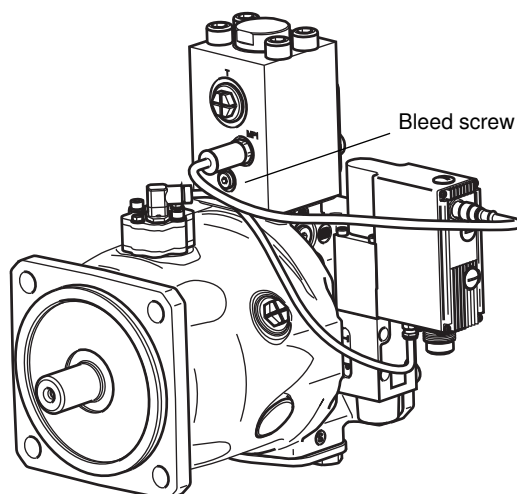

Fig. 28: Bleeding of the pre-load valve

**CAUTION!****Risk of injury!**

The case interior is pressurized to high pressure! Turning the bleed screw out too far can cause parts and hydraulic fluid to be ejected under pressure!

- ▶ Do not turn the bleed screw out too far (max. 2 turns)!

**7.1.6 Testing the hydraulic fluid supply**

The SY(H)DFEE control system must always be supplied with sufficient hydraulic fluid. For this reason, the supply of hydraulic fluid must be ensured at the start of the commissioning process.

When you test the hydraulic fluid supply, constantly monitor the noise development and check the hydraulic fluid level in the tank. If the SY(H)DFEE control system becomes louder (cavitation) or the case drain fluid flows out with bubbles, this is an indication that the SY(H)DFEE control system is not being sufficiently supplied with hydraulic fluid.

Notes on troubleshooting can be found in Chapter 14 "Troubleshooting" on page 70.

To test the hydraulic fluid supply:

1. Allow the motor to run at slowest speed. The SY(H)DFEE control system must be operated under no-load conditions. Pay attention to leakage and noise.
2. Check the SY(H)DFEE control system's case drain line during the test. The case drain fluid should not contain any bubbles.
3. Check the suction pressure at port "S" of the SY(H)DFEE control system pump. For the permissible value, please refer to data sheet RE 30030, RE 30630 and RE 30035.
4. Check the case drain pressure at connected port "K<sub>1</sub>" or "K<sub>2</sub>". Refer to data sheets RE 30030, RE 30630 and RE 30035 for permissible values.

**7.1.7 Possible adjustment work on the SYDFEE system**

The operating pressure is the pressure level, which the pump system is to generate as maximum value in the system.

The signal level of the pressure transducer, which is connected to the pump system, is converted into the normalized level of 0...10 V in the pilot valve and passed on as actual pressure value to the pressure controller.

The normalized actual pressure value can be measured at central plug-in connector pin 6 (reference M0 = pin 4).

Depending on the variant of the pilot valve, the corresponding pressure transducer signal is converted into the signal level of 0...10 V (factory default setting of the system).

Some examples:

- 4...20 mA is converted into 0...10 V (variant "C" in the type code)
- 1...10 V is converted into 0...10 V (variant "E" in the type code)

The pressure controller of the SY(H)DFEE.. system compares the level at the command value input (0...10 V) with the converted actual pressure value (0...10 V).

If the measuring range of the pressure transducer does not correspond to the operating pressure, controlling will not be based on the value of the operating pressure when the maximum pressure value is applied (+10 V), but on the final value of the pressure transducer measuring range.

## Commissioning

2 adjustment options are provided:

- Pressure command value adjustment
- Actual pressure value adjustment

### Pressure command value adjustment

For pressure command value adjustment, the pressure command value is normalized to the measuring range of the pressure transducer and fed forward accordingly.

With this procedure, no adjustment work is necessary on the pilot valve. This is especially advantageous in the case of pump systems, which are difficult to access.

Example:

Measuring range of the standard pressure transducer: 0... 315 bar

Selected operating pressure: 250 bar

The following is valid for the pressure value provision:

$$10 \text{ V} / 315 \text{ bar} = 31.7 \text{ mV/bar} (= \text{factor})$$

$$250 \text{ bar} \times 31.7 \text{ mV/bar} = 7.94 \text{ V}$$

This means that the pressure command value is normalized to the factor of 31.7 mV/bar.

In order to be able to feed the operating pressure value forward as pressure command value, a pressure command value of 7.94 V must be generated.

General formula:

Factor:  $10 \text{ V} / \text{measuring range of the pressure transducer}$

Pressure command value [bar]:

$$\text{Pressure} \times \text{factor} = \text{pressure command value [V]}$$

### Actual pressure value adjustment

In the case of actual pressure value adjustment, the actual pressure value is normalized to the operating pressure.

With the factory setting, pilot valve VT-DFPE-2X.. converts the signal of the pressure transducer internally into the range of 0... +10 V.

The signal range (= gain) of the actual pressure value can be changed with the help of potentiometer R2, which is located behind a screw on the pilot valve.

Proceeding while the system is running:

1. Close all directional valves. No fluid is allowed to flow.
2. Apply a swivel angle command value of  $> 5 \text{ V}$ .
3. Use potentiometer R2 behind the screw on the housing cover (see figure below) to adjust the operating pressure.

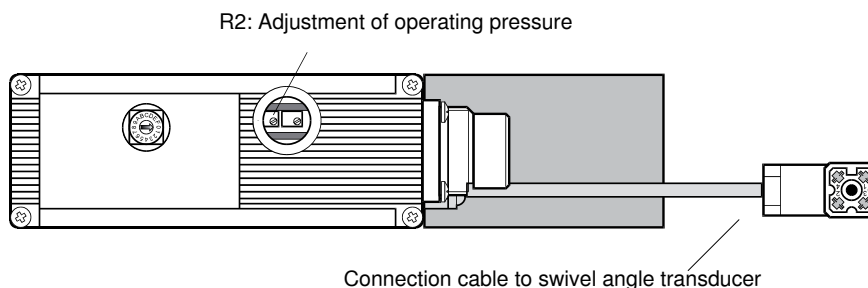

**Fig. 29: Actual pressure value adjustment**

4. Set the pressure command value to 5.00 V (= half operating pressure). After this, adjust the potentiometer until exactly half the operating pressure is

reached. For checking purposes, the max. operating pressure ( $p_{\max} / \pm 3$  bar) must be obtained at a command value of +10.0 V.



When you turn the potentiometer clockwise, the gain is reduced, that is, the pressure level is increased.

### 7.1.8 Optimizing the pressure controller

A decisive influence on the control dynamics of the pressure control loop has the oil volume between the actuator and the pump. Rotary switch S1 is used to match the controller with the connected oil volume. The switch is located behind the screw on the housing cover of the VT-DFP pilot valve (see Fig. 29).

Switch positions 0 to 7 repeat themselves with the positions from 8 to F (see table 5, center column).

For valve electronics with power controller with changeover feature (feature "12" in the type code is "A"; example: SYDFEE-2X/18R-PPA12N00-0000-A0A0FL1), a second volume matching can be activated via the PLC switching input "switch  $T_D$ " (pin 9 / +24 V). This second matching is in a fixed relationship with the setting of switch  $T_D = 0$  V as given in the right-hand column.

#### CAUTION!



#### Risk of damage to the product!

On valve electronics with other extra functions, pin 9 on the central plug-in connector serves as switchable pressure controller for other functions.

- ▶ With this valve type, under no circumstances may an external voltage be connected to this pin. This could lead to the destruction of the electronics

**Table 5: Optimization of the pressure controller for SYDFEE (adjustment of the coding switch)**

Switch position	0	1	2	3	4	5	6	7	8	9	A	B	C	D	E	F
<sup>1)</sup> $T_D$ OFF	≤5	6.25	7.5	10	12.5	15	20	25	≤5	6.25	7.5	10	12.5	15	20	25
$T_D$ ON <sup>2)</sup>	7.5	10	12.5	15	20	25	30	35	12.5	15	20	25	30	35	40	45

<sup>1)</sup> Connected hydraulic fluid volume of lines and actuators (in liters)

<sup>2)</sup> For the second line ( $T_D$  ON) exclusively variant "A" is relevant

Adjustment of the control loop

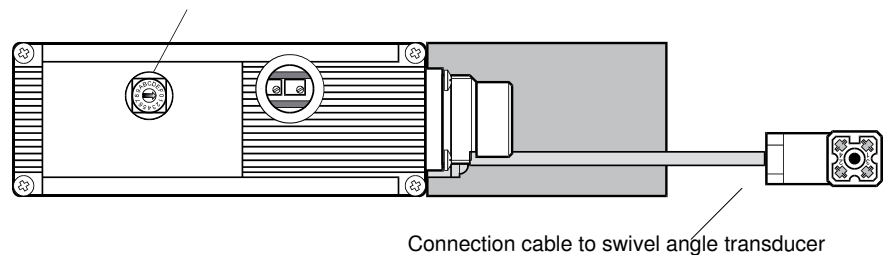

**Fig. 30: Optimization of the pressure controller**

#### Example

When optimizing the pressure controller you may find out that, for example, the best setting for the actuator in question is reached with an oil volume of 10 l (that is, optionally position -3- or -B-, see table 5).

If, however, the pump controls also other or more consumers, it is possible to select a second adjustment via switching input switch  $T_D$  ON (24 V) on the basis of this setting (switch position S1 -3- or -B-).

## Commissioning

If you select position -3- for switch S1, the volume adjustment of the controller can be changed over to 15 l by activating switch T<sub>D</sub> (+24 V).

If you select position -B- for switch S1 you can change over to an even greater oil volume (25 l) by activating switch T<sub>D</sub> (+24 V).

### 7.1.9 Adjusting the power limitation <sup>1)</sup>

The power limitation feature can be used to determine the maximum power consumption of the pump and thus protect the drive motor against overloading.

#### Example Calculation of the rated pump power

Motor power	$P_M = 15 \text{ kW}$
Speed	$n = 1500 \text{ min}^{-1}$
Displacement	$V_G = 100 \text{ cm}^3$ (pump size)
Maximum pressure	$p_{\text{max.}} = 200 \text{ bar}$
Efficiency	$\eta_{\text{mh}} = 1$ (theoretical value)

Maximum pressure = pressure [bar], at which the actual pressure value output of the valve (pin 8 of 11 + PE) provides +10 V.

$$P_{100\%} = \frac{V_G [\text{cm}^3] \cdot n [\text{min}^{-1}] \cdot p_{\text{max}} [\text{bar}]}{600.000 \eta_{\text{mh}}} \quad [\text{kW}]$$

$$P_{100\%} = 78.75 \text{ kW}$$

Calculation of the ratio

$$(p \cdot \alpha)_{\text{max}} = \frac{P_M}{P_{100\%}} \cdot 100 \% = 19 \%$$

Select the operating pressure of the system.

$$p_{\text{comm}} = \frac{10 \text{ V}}{350 \text{ bar}} \cdot 250 \text{ bar} = 7.94 \text{ V} (\hat{=} 79.4 \%)$$

In our example, it is 250 bar  $\hat{=} 7.94 \text{ V}$ .

Calculation of the max. swivel angle with performance limit

$$(p \cdot \alpha)_{\text{max}} = 19 \% (\hat{=} P_{\text{max}})$$

$$P_{\text{comm}} [\%] = 79.4 \% (\hat{=} 7.94 \text{ V})$$

$$\alpha_{\text{max}} = \frac{(p \cdot \alpha)_{\text{max}}}{P} = \frac{19 \%}{79.4 \%} \cdot 100 = 23.9 \%$$

<sup>1)</sup> Only on version with optional function "power limitation" (type code feature "12" is "B" or "C" - example: SYDFEE-2X/018R-PPA1200-0000-A0B1FL1).

### 7.1.10 Adjusting the constant power limitation with potentiometer R3

The power limitation can be set in two ways. Setting while the system is running should be preferred.

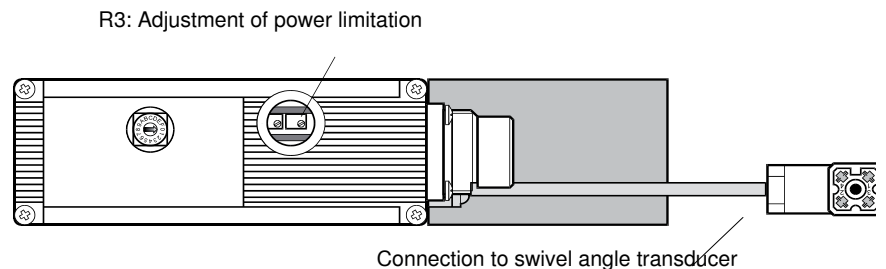

Fig. 31: Adjustment of power limitation

#### Adjustment while the system is running

For this method, you require:

- an adjustable pressure relief valve as variable load for the pump
- a measuring instrument for measuring the current consumption (or power consumption) of the drive motor.

In the description below, we utilize the data of the example above.

1. Close all directional valves, i.e. no oil flow
2. Set the pressure relief valve (DB) slightly higher than the maximum pressure ( $p_{\max} = 250 \text{ bar}$ ;  $p_{\text{DB}} = 270 \text{ bar}$ )
3. Select the max. operating pressure ( $p_{\max} = 250 \text{ bar}$ ) of the pump
4. Select a swivel angle command value greater than the calculated value ( $\alpha_{\text{comm}} > 3 \text{ V}$ )
5. Slowly turn out the DB - the pump now displaces into the DB - and, at the same time, measure the motor current (power); if it becomes too high, turn the DB in immediately.
6. Vary the flow from the pump by means of the DB until the nominal motor current flows; set the power limitation at this operating point.
7. Turn potentiometer R3 on the VT-DFPE-2X/... counter-clockwise until the signal "power limitation active" is issued (= 24 V).  
The signal "power imitation active" can be measured at central plug pin 9.



With the factory setting, potentiometer R3 is always set to maximum power (100 %). In this case, the potentiometer is at the "right-hand limit stop" position. To reduce the power limit, turn potentiometer R3 counter-clockwise.

#### Adjustment while the system is at a standstill

When making the adjustments while the drive motor is switched off, use the calculated maximum power as a guideline.

1. Drive motor OFF
2. Selection of pressure command value  $> 10 \text{ V}$ , e.g.  $10.5 \text{ V}$
3. Provision of actual pressure value at 10 ( $p_{\text{act\_High}}$ ) and 11 ( $p_{\text{act\_Low}}$ ) so that at pin 8 ( $p_{\text{act}}$ )  $+10 \text{ V}$  is measured.
4. Provide a swivel angle command value according to the desired power limit.
5. Turn R3 on the VT-DFPE-2X/... counter-clockwise until the signal "power limitation" is issued (= 24 V). The signal "power limitation active" can be measured at pin 9 of the central plug-in connector.

## Commissioning



With the factory setting, potentiometer R3 is always set to maximum power (100 %). In this case, the potentiometer is at the “right-hand limit stop” position. To reduce the power limit, turn potentiometer R3 counter-clockwise.

### 7.1.11 Performing a functional test

---

**WARNING!**

**Risk of injury in case of incorrectly connected machine or system!**

Any change of the connections will lead to malfunctions (e.g. lifting instead of lowering) and thus represents a corresponding hazard to persons and equipment.

- ▶ When connecting hydraulic components, observe the specified piping according to the hydraulic circuit diagram of the machine or system manufacturer.
- 

Once you have tested the hydraulic fluid supply, you must perform a functional test on the machine or system. The functional test should be carried out according to the instructions of the machine or system manufacturer.

---

Before delivery, the SY(H)DFEE control system is checked for functional capability in accordance with the technical data. During commissioning, it must be ensured that the SY(H)DFEE control system was installed in accordance with the plans and drawings of the machine or system. Use the swivel angle indicator to check whether the SY(H)DFEE control system swivels in and out correctly during operation.

The position of the swivel angle indicator and the assignment of the swivel direction to the direction of rotation and control can be found in the corresponding technical data sheets.

### 7.1.12 Bleeding during commissioning or after longer standstill periods

Just like during commissioning you have to bleed the SY(H)DFEE control system also after longer periods of standstill in order that the pump can build up pressure directly after the electric motor started up. The necessity for this depends, however, also on the installation orientation of the pump.

You can bleed the system manually by “opening” the pressure line at a suitable point (e.g. minimess port, valve, etc.). When an unloading valve to the tank is installed (quasi “pressureless start-up”), this procedure can also be automated when the electric motor starts up: The valve merely needs to be activated briefly; a continuous pressureless start-up as described in the following is not required.

If a SYDZ pre-load valve is installed and the pump does not build up pressure or displace hydraulic fluid, this valve must be bled additionally at point “P” as described in section 7.1.5 “Bleeding of the pre-load valve” on page 54.

## 7.2 Recommissioning after standstill

Depending on the installation conditions and ambient conditions, changes may occur in the system which make recommissioning necessary.

Among others, the following criteria may make recommissioning necessary:

- Air in the hydraulic system
- Water in the hydraulic system
- Aged hydraulic fluid
- Contamination

- ▶ For recommissioning, proceed as described in chapter 7.1 "First commissioning" on page 52.

### 7.3 Running-in phase

Bearings and sliding surfaces are subject to a running-in phase. Increased friction at the start of the running-in phase results in increased heat generation which decreases with increasing operating hours. The volumetric and mechanical-hydraulic efficiency rises as well by the end of the running-in phase of approx. 10 operating hours.

---

**CAUTION!****Risk of damage by insufficient viscosity!**

The increased temperature of the hydraulic fluid during the running-in phase can cause the viscosity to drop to impermissible levels.

- ▶ Monitor the operating temperature during the running-in phase.
  - ▶ Reduce the loading (pressure, speed) of the SY(H)DFEE control system, if impermissible operating temperatures and/or viscosities occur.
- 

## 8 Operation

The product is a component which requires no settings or changes during operation. For this reason, this chapter of the manual does not contain any information on adjustment options. Only use the product within the performance range provided in the technical data. The machine or system manufacturer is responsible for the proper project planning of the hydraulic system and its control.

## 9 Maintenance and repair

### 9.1 Cleaning and care

**CAUTION!**



**Damage to the surface caused by solvents and aggressive detergents!**

Aggressive detergents may damage the seals of the SY(H)DFEE control system and cause them to age faster.

- ▶ Never use solvents or aggressive detergents.

**CAUTION!**



**Contaminants and fluids entering the system will cause faults!**

This will result in the fact that the safe operation of the SY(H)DFEE control system can no longer be ensured.

- ▶ When carrying out any work on the SY(H)DFEE control system observe strictest cleanliness.
- ▶ Do not use high-pressure cleaners

For cleaning and care of the SY(H)DFEE control system, observe the following:

- ▶ Plug all openings with suitable protective caps/devices.
- ▶ Check whether all seals and plugs of the plug-in connections are securely seated to ensure that no moisture can enter the SY(H)DFEE control system during cleaning.
- ▶ Use only water and, if necessary, a mild detergent to clean the SY(H)DFEE control system.
- ▶ Remove coarse dirt from the outside of the system and keep sensitive and important components, such as solenoids, valves and displays, clean.
- ▶ Do not use high-pressure cleaners for cleaning the SY(H)DFEE control system.

### 9.2 Inspection

In order that the SY(H)DFEE control system works reliably and for a long time, Rexroth recommends that you inspect the SY(H)DFEE control system regularly at the following maintenance intervals and document the following operating conditions:

**Table 6: Inspection schedule**

Work to be carried out		Interval
Hydraulic system	Check level of hydraulic fluid in the tank.	Daily
	Check operating temperature (comparable load state).	Weekly
	Analyze quality of the hydraulic fluid.	Annually or every 2000 h (whichever occurs first)

Work to be carried out		Interval
SY(H)DFEE control system	Inspect the SY(H)DFEE control system for leakage. Early detection of hydraulic fluid loss can help identify and rectify faults on the machine or system. For this reason, Rexroth recommends that the SY(H)DFEE control system and the system as a whole always be kept in a clean condition.	Daily
	Check the SY(H)DFEE control system for generation of noise.	Daily
	Check mounting elements for proper fit. Inspect all mounting elements while the system is switched off, depressurized and cooled down.	Monthly

### 9.3 Maintenance

SY(H)DFEE control systems require little maintenance when used as intended. The service life of the SY(H)DFEE control system is heavily dependent on the quality of the hydraulic fluid. For this reason, we recommend changing the hydraulic fluid at least once a year or every 2000 operating hours (whichever occurs first) or having it analyzed by the hydraulic fluid supplier or a laboratory to determine its suitability for further use.

The service life of the SY(H)DFEE control system is limited by the service life of the built-in bearings. The service life can be requested on the basis of the load cycle from the responsible Rexroth Service partner, see Chapter 9.5 "Spare parts" below. Based on these details, a maintenance interval is to be determined by the system manufacturer for the replacement of the bearings and included in the maintenance schedule of the hydraulic system.

### 9.4 Repair



Rexroth offers a comprehensive range of services for the repair of Rexroth SY(H)DFEE control systems.

Repairs of the SY(H)DFEE control system may only be performed by authorized, skilled and instructed staff.

- ▶ Only use genuine spare parts from Rexroth for repairing Rexroth SY(H)DFEE control systems.

Partially tested and pre-assembled original Rexroth assemblies allow for successful repairs within a minimum of time.

### 9.5 Spare parts

#### CAUTION!



#### Personal injury and damage to property due to wrong spare parts!

Spare parts that do not meet the technical requirements specified by Rexroth may cause personal injury and damage property.

- ▶ Use only genuine spare parts from Rexroth.

When ordering spare parts, please indicate the material numbers of the relevant spare parts. On some components, the material number is shown on a nameplate or a label.

Please address all questions regarding spare parts to your responsible Rexroth Service partner.

## Maintenance and repair

Bosch Rexroth AG  
 Service Hydraulics  
 Bgm.-Dr.-Nebel-Str. 8  
 97816 Lohr am Main  
 Tel: +49 (0) 9352 - 18-0  
 Fax: +49 (0) 9352 - 18-39 83  
 spareparts.bri@boschrexroth.de

For the addresses of foreign subsidiaries, please refer to  
[www.boschrexroth.com/adressen](http://www.boschrexroth.com/adressen)

- ▶ Please state the following data from the nameplate on your order:
  - material number
  - serial number
  - production job order number
  - production date

### 9.5.1 Replacement of components

---

#### CAUTION!



#### Uncontrolled system behavior!

The failure of individual components can result in malfunction of the assembly!

- ▶ Replace or have defective components replaced immediately!
- 

The replacement of some components of the SY(H)DFEE control systems is described in the following.

#### Swivel angle sensor VT-SWA-1 for SYDFEE systems

The operating principle of VT-SWA swivel angle sensors, which work with a Hall sensor, is based on the evaluation of a magnetic field related to the rotary angle. The system operates contactless and is therefore wear-free.

In case that repairs have to be carried out on the swivel angle transducer of the SY(H)DFEE system, observe the installation notes for the VT-SWA swivel angle sensor and its magnet carrier. The material number for the kit, magnet carrier and seals included, is R900868651.

#### General

The magnet carrier is a sensitive component and must therefore be handled with care. It must not be subjected to impacts and be kept away from magnetizable or magnetic parts! Until the carrier is installed in the pump housing, the original packaging is the safest place of storage.

In the case of pump assemblies that were produced before 10/97, a spacer might have had to be installed under the magnet carrier for compensating for differences in height. If the "old" swashplate is used, this spacer must be re-installed. If new parts are used, the spacer is no longer required.

#### Installation of the magnet carrier

- ▶ Installation orientation with clockwise rotating pump:  
 The locating pin of the magnet carrier points towards the subplate of the pump (away from the drive motor). The bore for the locating pin is marked with a color point.
- ▶ Insert the magnet carrier in the receptacle provided in the housing of the A10 pump:  
 A special tool (plastic mounting sleeve, material no. R900846331) is required for inserting and tightening the countersunk screw! If this mounting sleeve is not available, use a suitable tool made of non-magnetic material for inserting

the mounting screw and for guiding a screw driver between the poles of the magnet.

- ▶ Tighten the countersunk screw M6 x 12 to 10.5 Nm.
- ▶ After having installed the magnet carrier, check with your fingers, whether the magnets positively adhere to the carrier.

Installation of rotary angle sensor VT-SWA-1-1X

- ▶ “Glue in” the O-ring of the kit in the groove using some grease.
- ▶ Tighten mounting screws M6 x 35 with washers to 15.5 Nm.
- ▶ Adjust the swivel angle sensor. Notes on the adjustment can be found in Chapter 14.2.1 “Checking the swivel angle measurement” on page 74.

Miscellaneous

- ▶ If the magnet carrier must be removed, also use a suitable mounting sleeve for loosening the countersunk screw (see note on “Installation of the magnet carrier”).

If the rotary angle sensor fails, proper operation of the SY(H)DFEE system is no longer possible.

#### Swivel angle sensor VT-SWA-LIN-1X for SYHDFEE systems

General

The prod is a sensitive component and must therefore be handled with care. In particular with regard to the magnetic properties, the prod must not be subjected to hard impacts and must be kept away from metal parts! Keep the prod in the original packaging until it is installed in the pump housing.

Installation of the rotary angle sensor VT-SWA-LIN-1X

- ▶ Tighten sensor to 25 +5 Nm (27 A/F)
- ▶ Adjust the swivel angle sensor. Notes on the adjustment can be found in Chapter 14.2.1 “Checking the swivel angle measurement” on page 74.
- ▶ Measure the actual swivel angle value and set it to 10.05 V +0.01 V (corresponds to maximum stroke) using potentiometer “G”.
- ▶ In some cases, the pump will not swivel out to the positive stop. For this reason, switch the motor on briefly, then switch off, wait until the pump has swiveled out and then measure the actual swivel angle value. If a higher voltage is measured, correct the value. Repeat this procedure several times.

#### Seal kits for the pump

Stating the Mat. no. of the pump you can order seal kits, which are either tailored to the individual component or grouped in a complete package.

#### Pilot valve VT-DFPE-x-2X

The pilot valve is a component, which is sensitive to contamination. When replacing it, take care that no contaminants can enter fluid-carrying parts of the valve and the pump. To replace the pilot valve loosen the 4 screws at the recessed corners of the nameplate on the pilot valve. After the replacement, tighten the screws to a tightening torque of 7 Nm ±10 %. Newly installed valves with integrated electronics need to be adjusted:

- ▶ Take the parameter setting of the coding switch over from the demounted valve.
- ▶ Check the calibration of the actual pressure value and, if required, readjust as described on page 56.
- ▶ Check/calibrate the actual swivel angle value on the VT-SWA-1X, see page 74.

## Maintenance and repair

**Pre-load valve SYDZ0001**

To replace the pre-load valve, loosen the mounting screws and remove the pre-load valve.

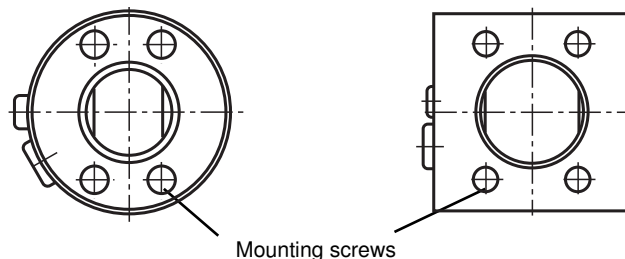

**Fig. 32: Mounting bores: left-hand side (round) for NG18, 28, 25; right-hand side (rectangular) for NG 71, 100, 140**

When positioning a new pre-load valve, take care that the seal on the pump side to the pre-load valve is located in the recess provided for this purpose. Tighten the mounting screws to the following torque:

Sizes 18, 28 und 45: 45 Nm

Size 71: 55 Nm

Sizes 100 and 140: 100 Nm

After having mounted the pre-load valve, connect the pipes for high pressure and case drain oil as described in chapter 6.3 "Installation positions and piping of SY(H)DFEE systems". During re-commissioning, bleed the pre-load valve. Notes on the bleeding procedure can be found in Chapter 7.1.5 "Bleeding the pre-load valve" on page 54.

**HM16-1X**

Disconnect the electrical connection on the pilot valve. Replace the pressure transducer by turning out the existing pressure transducer and screwing in a new one. Tighten the pressure transducer to a torque of 15 Nm.

**9.5.2 Test devices, assembly tools and note on commissioning****Test box for SYDFEE und SYDFEC**

We offer a hand-held control box, designation "VT-PDFE-1-1X/V0/V0" (Mat. no. R900757051) for control systems SY(H)DFEE, SY(H)DFEC and SY(H)DFEn for looping in into the existing cabling.

The hand-held control box requires a 24 V voltage supply from the customer side for the internal reference voltage and is equipped with:

- Command value potentiometer for swivel angle and pressure
- Measuring points for all connection pins
- Additional supply option for a pressure transducer

**Fitting tool for VT-SWA-1 swivel angle transducer (Hall sensor) for SYDFEE-/2X, SYDFEC-2X and SYDFEn**

The following fitting tool is available for the magnet carrier:

- For mounting: "Installation aid for carrier of VT-SWA", Mat. no. R900846331

## 10 Decommissioning

The SY(H)DFEE control system is a component that does not require decommissioning. For this reason, this chapter of the present instructions does not contain any information.

For details about how to disassemble or replace your SY(H)DFEE control system, please refer to Chapter 11 “Demounting and replacement” below.

## 11 Demounting and replacement

### 11.1 Required tools

Disassembly can be performed with standard tools. No special tools are necessary.

### 11.2 Preparing demounting

---

**WARNING!****Risk of injuries due to demounting under pressure and voltage!**

If you do not switch off the pressure and power supply before demounting the product, you may get injured or the device or system components may be damaged.

- ▶ Make sure that the relevant system components are not under pressure or voltage.

1. Decommission the entire system as described in the general instructions for the machine or system.
2. Depressurize the hydraulic system according to the instructions of the machine or system manufacturer.

### 11.3 Demounting the SY(H)DFEE control system

Proceed as follows to demount the SY(H)DFEE control system:

1. Make sure that the hydraulic system is depressurized.
2. Check that the SY(H)DFEE control system has cooled down sufficiently so that it can be uninstalled without any risks.
3. Place a catch pan under the SY(H)DFEE control system to collect any hydraulic fluid that may escape.

---

**CAUTION!****Danger of environmental pollution!**

The discharge or spillage of hydraulic fluid while filling the SY(H)DFEE control system can lead to environmental pollution and contamination of the groundwater.

- ▶ When filling and changing the hydraulic fluid, always place a catch pan under the SY(H)DFEE control system.
  - ▶ Observe the information in the safety data sheet for the hydraulic fluid and the specifications provided by the system manufacturer.
-

## Disposal

1. Loosen the lines and collect the escaping hydraulic fluid in the collector provided for this purpose.
2. Remove the SY(H)DFEE control system. Use suitable lifting gear for this.
3. Drain the SY(H)DFEE control system completely.
4. Plug all openings.

### 11.4 Preparing the components for storage or further use

- ▶ Proceed as described in Chapter 5.2 "Storing the SY(H)DFEE control system" on page 34.

## 12 Disposal

### 12.1 Environmental protection

Careless disposal of the SY(H)DFEE control system, the hydraulic fluid and the packaging material could lead to pollution of the environment.

- ▶ Therefore, dispose of the SY(H)DFEE control system, the hydraulic fluid and the packaging material in accordance with the currently applicable regulations in your country.
- ▶ Dispose of hydraulic fluid residues according to the applicable safety data sheets for these hydraulic fluids.

### 12.2 Return to Bosch Rexroth

Products manufactured by us can be returned to us free of charge for disposal. However, a precondition is that the products are free from any deposits or other contaminations. Hydraulic products must be drained before being returned. Moreover, the products must not contain any unacceptable foreign particles or components of other make.

Please return the products free domicile to the following address:

Bosch Rexroth AG  
Service Industriehydraulik  
Bürgermeister-Dr.-Nebel-Straße 8  
97816 Lohr am Main  
Deutschland

### 12.3 Packaging

For regular deliveries we can use re-usable systems. The materials used for disposable packagings are mainly cardboard, wood and styrol. These can be recycled without any problems. However, for ecological reasons, the use of disposable packagings should be avoided for return shipments to us.

## 12.4 Materials used

Our products do not contain any hazardous substances that could be released during proper use. In normal cases, no negative effects on man and environment have to be expected.

The products basically consist of:

- Cast iron
- Steel
- Aluminum
- Copper
- Plastics
- Electronic components and assemblies
- Elastomers

## 12.5 Recycling

Due to the large metal content our products can be recycled to a great extent. To ensure optimum metal recycling, the units must be disassembled to obtain individual assemblies. Metals contained in the electrical and electronic assemblies can also be recycled using specific separating procedures. As far as products contain any batteries, these must be removed prior to the product recycling and should be recycled as well whenever possible.

## 13 Extension and conversion

The SY(H)DFEE control system may only be converted or extended in the cases described below using genuine Rexroth SY(H)DFEE components. Other conversions or extensions, also the readjustment of lead-sealed adjustment potentiometers render the warranty void. The replacement of a component with a component of the identical design is described in Chapter 9.5 "Spare parts" on page 63.

An extension by adding a SYDZ pre-load valve is possible on the SYDFEE control system, but not on the SYHDFEE control system. Please ensure that the size of the pre-load valve and the size of the pump are identical. If the control system is provided with an HM16 pressure transducer at the valve ex factory, the pressure transducer must be removed and re-mounted to the pre-load valve, because the pressure at the pump and the pressure in pressure port P1 of the pre-load valve may be different.

If an HM 16 pressure transducer is mounted on the pre-load valve or the pump of the control system, the pressure transducer can be removed and re-mounted at another position within the system. In this case, the connection for the pressure transducer must be plugged with a plug, which is suitable for high pressure applications. For the installation, observe the notes given in Chapter 6.6.3 "Selection, place of installation and mounting orientation of the pressure transducer" on page 48.

## 14 Troubleshooting

The following table may assist you in troubleshooting. The table is not exhaustive. In practice, problems which are not listed here may also occur.

### 14.1 How to proceed for troubleshooting

- ▶ Always act systematically and targeted, even under pressure of time. Random and imprudent disassembly and readjustment of settings might result in the inability to ascertain the original cause of fault.
- ▶ First obtain a general overview of how your product works in conjunction with the entire system.
- ▶ Try to determine whether the product worked properly in conjunction with the entire system before the troubles occurred.
- ▶ Try to determine any changes of the entire system in which the product is integrated:
  - Were there any changes to the product's operating conditions or operating range?
  - Were there any changes or repairs on the complete system (machine / system, electrics, control) or on the product? If yes, which?
  - Was the product or machine used as intended?
  - How did the malfunction manifest itself?
- ▶ Try to get a clear idea of the error cause. Directly ask the (machine) operator.
- ▶ If you cannot rectify the error, contact one of the contact addresses which can be found at:  
[www.boschrexroth.com/adressen](http://www.boschrexroth.com/adressen)

## 14.2 Malfunction table

**Table 7: Malfunction table for SY(H)DFEE control systems**

Fault	Possible cause	Remedy
Error output (X1, Pin 3) is 0-5 V	Error in the actual pressure value branch Diagnosis: Actual pressure value normalized (X1, pin 8) is less than -0.5 V or greater than 11.5 V	Test actual pressure value signal (X1, pin 10 and 11) (wire rupture, working range, signal type, polarity)
	Error in the actual swivel angle value branch Diagnosis: Actual swivel angle value normalized (X1, pin 6) is less than -11.5 V or greater than +11.5 V	Check wiring and function of the swivel angle transducer (see page 74)
	Excessive control error of the pressure and swivel angle controller	Adjust the command values for pressure and swivel angle to the actual values (e.g. 0 bar / +100 %) while the drive motor is switched off
	Temperature limit value exceeded in the housing (ca. 80 °C)	Reduce ambient temperature to below 60 °C, increase air movement in the surroundings
	Actual valve value less than -11.5 V or greater than +11.5 V	Contact Rexroth Service
	Voltage symmetry of internal voltages of the pilot valve outside the limit value	Contact Rexroth Service
Humming noise in the pressure control or fluctuations in pressure / flow	Air cushion around the sensor	Bleed control system, pre-load valve (see page 54) and pipes completely
	Problem with the cable shield	Ground shield
	No connection from M0 to L0	Connect M0 (X1, pin 4) and L0 (X1, pin 2) in the control cabinet
	Unfavorable place of mounting / mounting technique of the pressure transducer	Change place of installation (e.g. suspended mounting, no minimess line, no throttling point between pump and pressure transducer)
	Unsuitably high gain of the actual pressure value	Reduce weighting of the actual pressure value and pressure command value, see page 56
Screaming noise	Oil level in the tank too low; pump partly aspires air	Top up oil
	Pump aspires air	Change the routing of the suction line
	Suction line leaky	Seal suction line
	Pump cavitates when pressure is reduced Diagnosis: Measure, whether the pressure in the pressure line overshoots	Optimize controller, reduce the command value via a ramp or in steps.
	Fluid in the tank mixed with air; cooling and/or filtration circuit leaky	Seal

Troubleshooting

Table 7: Malfunction table for SY(H)DFEE control systems

Fault	Possible cause	Remedy
Other unusual noise	Input speed too high	Machine or system manufacturer
	Wrong direction of rotation	Machine or system manufacturer
	Insufficient suction conditions, e.g. air in the suction line, insufficient diameter of the suction line, viscosity of the hydraulic fluid too high, suction height too great, suction pressure too low, foreign body in the suction line	Check, whether shut-off valves are open
		Machine or system manufacturer (e.g. optimize inlet conditions, use suitable hydraulic fluid)
		Completely air-bleed control system, fill suction line with hydraulic fluid
		Remove foreign body from the suction line
	Improper mounting of the control system.	Check mounting of the control system according to the instructions given by the machine or system manufacturer. Observe tightening torques.
	Improper mounting of connected parts, e.g. coupling and hydraulic lines	Mount attachments in accordance with the instructions of the coupling or fitting manufacturer
Air in the pump or in the pre-load valve	Bleed pump and pre-load valve	
Wear of / mechanical damage to the control system	Replace control system, contact Rexroth Service	
No or insufficient pressure (< 4 bar)	Faulty mechanical drive (e.g. defective coupling)	Machine or system manufacturer
	Hydraulic fluid not within the optimum viscosity range	Use suitable hydraulic fluid (machine or system manufacturer)
	Drive unit defective (e.g. hydraulic motor or cylinder)	Machine or system manufacturer
	Wear / mechanical damage	Replace control system, contact Rexroth Service
Pressure fixed, ca. 5...12 bar, cannot be changed	Supply voltage not within the permissible range (23...33.6 V) Diagnosis: Is the actual swivel angle value (X1, pin 6) 0 Volt? If yes, is the supply voltage missing?	Check, whether central plug-in connector X1 is connected to the pilot valve
		Check voltage at the last interconnection point (terminal strip) before the pilot valve
	Command value for pressure, swivel angle or power (optional) is 0 bar or 0 %, respectively	If you utilize, for example, only closed-loop pressure control, connect the swivel angle command value (X1, pin 5) to +10 V
		The potentiometer for the (optional) power limitation must not be at the left-hand limit stop
	Swivel angle sensor defective	Inspect swivel angle sensor, see page 74
Spool jams in pilot valve	Contact Rexroth Service	

Table 7: Malfunction table for SY(H)DFEE control systems

Fault	Possible cause	Remedy
Pressure too low (< 12 bar)	Evaluation of the actual pressure value is incorrectly set Diagnosis: Pressure command value (X1, pin 7) and actual pressure value normalized (X1, pin 8) are equal and can be controlled	Adjust pressure command value and/or actual pressure value (see 7.1.6)
		Replace pressure transducer
		Change place of installation of the pressure transducer (do not install upstream of the pre-load valve, rather close to the consumer)
	Pressure transducer defective / not connected Diagnosis: Measure signal from pressure transducer and compare with indication on the pressure gauge	Replace pressure transducer
	Control system does not work in closed-loop pressure control Diagnosis: Pressure command value (X1, pin 7) normalized is less than actual value (X1, pin 8) normalized	Increase swivel angle command value Increase power limit (see page 58)
	Check, whether hydraulic system is leak-free and the consumption is not too great .	
	Pilot valve defective	Replace pilot valve
Pressure too high	Evaluation of the actual pressure value is incorrectly set Diagnosis: Pressure command value (X1, pin 7) and actual pressure normalized (X1, pin 8) are equal and can be controlled	Adjust pressure command value and/or actual pressure value (see page 56)
		Replace pressure transducer
		Replace pilot valve, see page 65
	Pressure transducer (PT) defective / not connected Diagnosis: Measure signal from PT and compare with indication on the pressure gauge	Replace pilot valve, see page 65
Flow too small	Pressure controller active	Increase pressure command value
	Power limitation (optional) active.	Increase power command value (optional) (see page 59)
	Actual swivel angle acquisition maladjusted	Adjust swivel angle sensor (see page 75)
	Speed of drive too low (slip, incorrect frequency, wrong motor)	Machine or system manufacturer
	Pump damaged (pump leakage too great)	Rotary group defective
	Wear / mechanical damage to the control system	Replace control system, contact Rexroth Service.
Drive motor switches off due to overloading	Excessive power consumption of the pump	Reduce power command values (optional (see page 58)) Reduce swivel angle command value Test actual pressure value acquisition (see page 56)
	Protective overcurrent feature of the motor does not work properly	Check setting and test function
	Spool jams in pilot valve Diagnosis: Disconnect central plug-in connector X1 or supply voltage from pilot valve and test whether the motor is still overloaded	Replace pilot valve, see page 65
	Actual swivel value acquisition maladjusted or does not work	Check actual swivel angle acquisition, see page 74
	Valve electronics defective	Replace pilot valve, see page 65

## Troubleshooting

**Table 7: Malfunction table for SY(H)DFEE control systems**

Fault	Possible cause	Remedy
Hydraulic fluid temperature too high	Inlet temperature at control system too high	Inspect system, e.g. malfunction of cooler, insufficient hydraulic fluid in the tank
	Pre-load valve opens Diagnosis: Pipe to the tank heats up	Pressure must be lower than cracking pressure of pre-load valve. Keep overshoots and pressure pulsations to a minimum
	Malfunction of pressure control valves (e.g. high pressure relief valve, pressure cut-off valve, pressure controller)	Contact Rexroth Service.
	Control system worn out	Replace control system, contact Rexroth Service

### 14.2.1 Checking the swivel angle measurement

The settings for swivel angle measurement are made in the factory. The settings described below are only required after a replacement of the swivel angle transducer.

Depending on circumstances, a calibration of the swivel angle "100 %" can be conducted while the drive motor is running or at rest.

#### Checking swivel angle "zero" (while system is running)

- Close all directional valves
- Apply a swivel angle command value of >5 V
- Apply a pressure command value of 20 bar
- Check, whether the actual swivel angle value ( $\alpha_{act}$ ) is 0 V  $\pm$ 100 mV
- In the case of deviations, correct by means of potentiometer (1); the potentiometer is marked with "O" (= Offset)

#### Checking swivel angle "100%" (while system is running)

- Swivel angle command value greater than 10.5 V, pressure command value ca. 5 V
- Direct the full flow via the actuator, e.g. activate hydraulic motor or set pressure relief valve to ca. 20 bar; in this case, the pilot valve deliberately signals an error (control deviation too great)
- Adjust potentiometer (2) until the actual swivel angle value is +10.05 V; the potentiometer is marked with "G" (= gain) on the swivel angle transducer (corresponds to maximum stroke).

#### Checking swivel angle "100%" (while drive motor is switched off)

- Switch the hydraulic system off and wait for ca. 5 min until the pump has swiveled out mechanically (wait until pressure has decreased completely).
- Turn potentiometer (2) until the actual swivel angle value is +10.05 V; the potentiometer is marked with "G" (= gain) on the swivel angle transducer.
- In some cases, the pump will not swivel out to the positive stop. For this reason, switch the motor on briefly, then switch it off again and wait until the pump has swiveled out. Measure the actual swivel angle value. If a higher voltage is obtained, correct the value.  
Repeat this process several times!

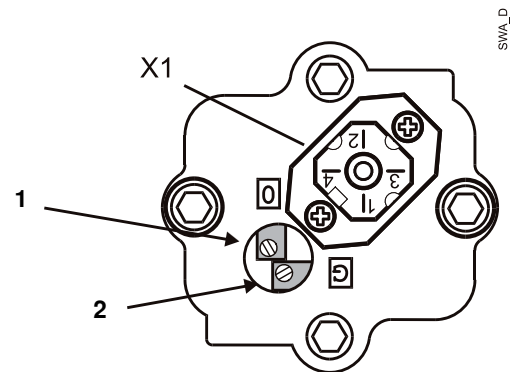

Fig. 33: Swingle angle sensor for SYDFEE

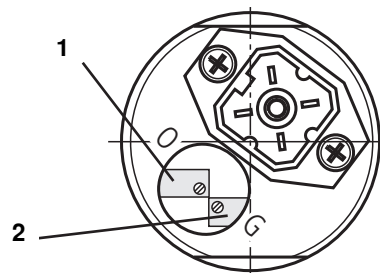

Fig. 34: Swingle angle sensor for SYHDFEE

- 1 Zero point adjustment of swivel angle
- 2 Setting of max. swivel angle

## 15 Technical data

The technical data of your SY(H)DFEF system are contained in the following data sheets:

SYDFEE series 2X            RE 30030

SYDFEE series 3X            RE 30630

SYHDFEE series 1X        RE 30035

The data sheet can be found on the Internet at

[www.boschrexroth.com/ics](http://www.boschrexroth.com/ics)

The preset technical data of your SY(H)DFEE control system can be found in the order confirmation.

## 16 Annex

### 16.1 Address directory

For the addresses of our foreign subsidiaries and responsible sales companies, please visit <http://www.boschrexroth.com>.

#### Contact for repairs and spare parts

Bosch Rexroth AG  
Service Industriehydraulik  
Bürgermeister.-Dr. Nebel-Str. 8  
97816 Lohr am Main  
Germany

Our spare parts catalog can be found on the Internet at  
<http://www.boschrexroth.com/spc>  
Here you can find also your technical contact

Contacts for repairs are listed on the Internet at:  
<http://www.boschrexroth.com/service>

#### Ordering address for accessories and valves

Headquarters:  
Bosch Rexroth AG  
Hydraulics  
Zum Eisengießer 1  
97816 Lohr am Main  
Germany  
Phone +49 (93 52) 18-0  
or the relevant sales subsidiary.

#### Addresses can be found on the Internet at:

<http://www.boschrexroth.com>

For the addresses of foreign subsidiaries, please refer to  
[www.boschrexroth.com/adressen](http://www.boschrexroth.com/adressen)



## 17 Alphabetical index

### A

Abbreviations 6  
Activation sequence 31  
Actual pressure value adjustment 56  
Actuating system supply 13  
Address directory 76  
Adjusting  
    constant power limitation 59  
Adjusting the power limitation 58  
Adjustment work 55  
Ambient conditions 22  
Ambient temperature 22  
Assembly tools 66

### B

Basic operating modes 15  
Bleeding 60  
Bleeding the pre-load valve 54  
Brief regenerative operation 19

### C

Cabling 47  
Care 62  
Case drain oil compensation 27  
Case drain piping 39  
Caution 8  
Checking 74  
    swivel angle "100%" 74  
    swivel angle measurement 74  
    swivel angle "zero" 74  
Circulation operation 17  
Cleaning 62  
Commissioning 51  
    first 52  
Connecting  
    electrically 46  
    hydraulically 43  
Controller structure 15  
Conversion 69

### D

Danger 8  
Data sheet 5  
Decommissioning 67  
Delivery contents 11  
Demounting 67  
Device description 12  
Dimensions 32  
Direction of rotation 41  
Disposal 68  
Dimensioning 22

### E

Environmental protection 68  
Extension 69  
External pilot oil supply 21

### F

Filling 52  
Filtration 24  
Flushing cycle 53  
Functional description 12  
Functional test 60

### G

Generation of noise 25

### H

HFC fluids 24  
HM12 50  
HM13 50

### I

Identification of the product 31  
Improper use 7  
Inspection 62  
Inspection schedule 62  
Installation 36  
    with coupling 41  
Installation conditions 36  
Installation drawing 5  
Installation positions 37  
Installing the SY(H)DFEE control system 40  
Intended use 7  
Internal pilot oil supply 21

### K

Keyed shaft 25

### M

Maintenance 62, 63  
Malfunction table 71  
Master/slave operation 28  
Maximum system pressure 20  
Minimum system pressure 21

### N

Nameplate 31  
Noise level 24

### O

Obligations 10  
Oil-immersed applications 22  
Open circuit 12  
Operating pressure  
    Limits 20  
        maximum 20  
        Minimum 21  
Operating viscosity 23  
Operation 61  
Optimizing the pressure controller 57

Order confirmation 5  
Ordering address 76

## P

Packaging 68  
Performance description 12  
Pilot oil 21  
    external 21  
    internal 21  
Piping 37, 38  
Power limitation 16, 27  
Power supply 47  
    VT-DFPE pilot valve 47  
Pre-load valve 21  
Preparation 40  
Pressure command value adjustment 56  
Pressure control 16  
    closed-loop 16  
Pressure controller with changeover feature 26  
Pressure transducer  
    mounting orientation 48  
    place of installation 48  
    selection 48  
Product description 12  
Pulsation damper 25

## Q

Qualifications 7

## R

Recommissioning 60  
    after downtime 60  
Regenerative operation 18  
    brief 19  
    continuous 18  
Related documents 5  
Repair 63  
Replacement 67  
Replacement of components 64  
Return 68  
Routing of lines 43  
Running-in 61

## S

Safety instructions 7, 8  
Seal kits 65  
Section 12  
Shaft version 25  
Spare parts 63  
Special operating modes 17  
Splined shaft 26  
Spool variant 26  
Stand-by operation 17  
Starting up at zero pressure 17  
Storage 32  
Storing 34

Switching on  
    drive motor of the pump 54  
    supply voltage for the electronics 53  
Swivel angle adjustment 14  
Swivel angle control 15

## T

Technical data 75  
Temperature range 23  
Test devices 66  
Testing the hydraulic fluid supply 55  
Tightening torques 45  
Transport 32  
Troubleshooting 70

## U

Unpacking 36

## V

Viscosity limits 23

## W

Warning 8  
Warranty 9  
Weights 32

## Z

Zero stroke operation 17  
Zero stroke pressure 14

Bosch Rexroth AG  
Hydraulics  
Zum Eisengießer 1  
97814 Lohr a. Main, Deutschland  
Phone +49 (0) 93 52/18-0  
Fax +49 (0) 03 52/18-2358  
[documentation@boschrexroth.de](mailto:documentation@boschrexroth.de)  
[www.boschrexroth.com](http://www.boschrexroth.com)