

Press module for die cushion

Type IH04E

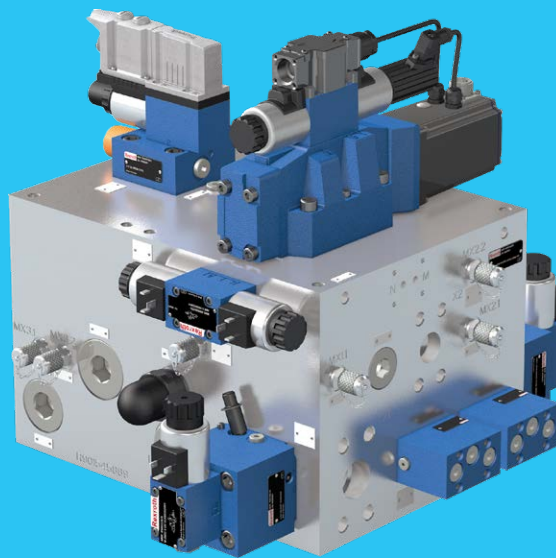

The data specified above only serve to describe the product. No statements concerning a certain condition or suitability for a certain application can be derived from our information. The information given does not release the user from the obligation of own judgment and verification. It must be remembered that our products are subject to a natural process of wear and aging.

© All rights are reserved to Bosch Rexroth AG, also regarding any disposal, exploitation, reproduction, editing, distribution, as well as in the event of applications for industrial property rights.

The cover shows an example configuration. The product supplied may therefore differ from the figure shown.

The original assembly instructions were prepared in German.

Contents

1	About this documentation	5
1.1	Validity of the documentation	5
1.2	Required and additional documentation	5
1.3	Representation of information	6
1.3.1	Safety instructions	6
1.3.2	Symbols	7
1.3.3	Abbreviations	7
2	Safety instructions	8
2.1	About this chapter	8
2.2	Intended use	8
2.2.1	Classification according to Directive 2006/42/EC	9
2.2.2	Limits of use	9
2.3	Improper use	10
2.4	Qualification of personnel	10
2.5	General safety instructions	11
2.5.1	General safety instructions for press modules type IH04E	11
2.6	Product- and technology-dependent safety instructions	12
2.7	Personal protective equipment	15
2.8	Information of the machine manufacturer	15
2.9	Obligations of the machine end-user	15
3	General information on damage to property and damage to product	16
4	Scope of delivery	18
5	Product information	19
5.1	Product description	19
5.2	Description of safety-relevant components	20
5.2.1	Functional safety for hydraulic presses	20
5.2.2	Application example	20
5.3	Product identification	22
6	System design and installation	23
6.1	Installation conditions and position	23
6.2	Safety equipment	24
6.3	System design	24
6.3.1	Limitation of the operating pressure	24
6.3.2	Design of pressure relief valves .150/.151	24
6.3.3	Prevention of access in the danger zone	24
6.3.4	Leakage through the safety-relevant valves .140, .142 and .170	24
6.3.5	Reaction time (response time) of stop function	25
6.3.6	Protection class	25
6.3.7	Dimensioning of nozzles .143, .148 and .181	25
6.3.8	Piping between cylinder piston side and port X1	25
6.3.9	Using the connection port DB	25
6.3.10	Interaction with other functions	25

6.4	Electrical control system	26
6.4.1	Safe separation from the energy supply	26
6.4.2	Emergency stop	26
6.4.3	Safety-related function "Safe reduced velocity"	26
6.4.4	Evaluation of the limit switch signals of the monitored valves .140 and .145	26
6.4.5	Safety signals	27
6.5	Fault detection	27
6.5.1	Control and evaluation of the limit switch signals	27
6.5.2	Malfunction caused by safety-relevant faults	28
7	Commissioning	29
7.1	First commissioning	31
7.2	Bleeding the hydraulic system	31
7.3	Commissioning of the basic module .100 and extension module .105	32
7.3.1	General information	32
7.3.2	Setting the maximum drawing/operating pressure .130 to .132 (extension module .105)	33
7.3.3	Setting the pressure limitation against pressure intensification .150/.151	34
7.3.4	Safe reduced velocity (<10 mm/s) - replacement of nozzles .171 and .172	34
7.4	Commissioning of extension modules .230 and .270	36
7.4.1	Extension module .230 with regenerative circuit	36
7.4.2	Extension module .270 with load sensing	38
7.5	Performing tests	39
8	Disposal	40
8.1	Environmental protection	40
8.2	Return to Bosch Rexroth AG	40
8.3	Packaging	40
8.4	Materials used	40
8.5	Recycling	41
9	Troubleshooting	42
9.1	How to proceed for troubleshooting	42
10	Technical data	44
11	Alphabetical index	45

1 About this documentation

1.1 Validity of the documentation

This documentation applies to the following products:

- Press module for die cushion, type IH04E

This documentation is intended for assemblers, service engineers, machine manufacturers and machine end-users.

This documentation contains important information to design and install the product, identify errors in design, put the product into operation, and eliminate simple faults.

- ▶ Read this documentation thoroughly, and in particular chapter 2 "Safety instructions" and chapter 3 "General information on damage to property and damage to product", before handling the press module type IH04E.
- ▶ Also read the operating instructions 63124-B and the data sheet 63129 before working with the press module type IH04E.

1.2 Required and additional documentation











- ▶ The product must not be commissioned until you have been provided with the documentation marked with the book symbol  and you have understood and observed it.

Table 1: Required and additional documentation

Title	Document number	Document type
 Press modules for hydraulic presses, type IH04	63124-B	Operating instructions
 Press module for die cushion, type IH04E	63129	Data sheet
 2-way cartridge valve pressure functions, cartridge valves type LC..., control cover type LFA...	21050	Data sheet
 Pressure-controlled direct operated proportional pressure relief valve with integrated electronics (OBE), type DBETA	29262	Data sheet
 2-way cartridge valve, actively controllable, type LC2A	21040	Data sheet
 2-way cartridge valve, actively controllable, type LC2A016...125	21040-MON	Assembly instructions
 Pressure relief valve, direct operated, type DBD	25402	Data sheet
 Directional spool valves, direct operated, with solenoid actuation, type WE	23178	Data sheet
 Directional spool valves, pilot-operated, with hydraulic or electro-hydraulic actuation, type WEH and WH	24751	Data sheet

The press module type IH04E is a system component.

- ▶ Also observe the instructions for the other system components and the system manufacturer's documentation for the overall machine/system.

1.3 Representation of information

Uniform safety instructions, symbols, terms and abbreviations are used so that you can quickly and safely work with your product using this documentation. For a better understanding, they are explained in the following sections.

1.3.1 Safety instructions



In this documentation, safety instructions are indicated whenever sequences of actions are explained which bear the risk of personal injury or damage to property. The measures described for hazard avoidance must be observed.

Safety instructions are structured as follows:

 SIGNAL WORD
<p>Type and source of danger</p> <p>Consequences in case of non-compliance</p> <ul style="list-style-type: none"> ▶ Hazard avoidance measures ▶ <Enumeration>

- **Warning sign:** Draws attention to the danger
- **Signal word:** Identifies the degree of danger
- **Type and source of danger:** Specifies the type and source of danger
- **Consequences:** Describes the consequences of non-compliance
- **Precaution:** Specifies how the danger can be prevented

Table 2: Risk classes according to ANSI Z535.6-2006

Warning sign, signal word	Meaning
 DANGER	Indicates a dangerous situation which will cause death or severe injury if not avoided.
 WARNING	Indicates a dangerous situation which may cause death or severe injury if not avoided.
 CAUTION	Indicates a dangerous situation which may cause minor or medium (personal) injury if not avoided.
NOTICE	Damage to property: The product or the environment could be damaged.

1.3.2 Symbols

The following symbols indicate notes which are not safety-relevant but increase the comprehensibility of the documentation.

Table 3: Meaning of the symbols

Symbol	Meaning
	If this information is not observed, the product cannot be optimally used and/or operated.
▶	Individual, independent action
1.	Numbered instruction: The numbers indicate that the actions must be carried out one after the other.
2.	
3.	

1.3.3 Abbreviations

The following abbreviations are used in this documentation:

Table 4: Abbreviations

Abbreviation	Meaning
DB	Pressure relief valve
RE	R exroth document in the E nglish language
REXXXX-B	R exroth operating instructions in E nglish language
REXXXX-MON	R exroth assembly instructions in E nglish language

2 Safety instructions

2.1 About this chapter

The press module type IH04E was designed and manufactured according to the generally accepted code of practice. However, there is still the danger of personal injury and damage to property if you do not observe this chapter and the safety instructions in this documentation.

- ▶ Read this documentation completely and thoroughly before working with the press module type IH04E.
- ▶ Keep this documentation in a location where it is accessible to all users at all times.
- ▶ Always include the required documentation when you pass the press module type IH04E on to third parties.
- ▶ Additionally, please observe the safety instructions for the overall machine/system.

The safety instructions in these instructions only refer to the scope of delivery. Due to the interaction between the press module IH04E and the overall machine/system, the installation of the press module IH04E into the machine involves additional hazards. This applies in particular to the influence of hydraulic and electric controls on hydraulic drives which generate mechanical movements. It is therefore essential for the manufacturer of the overall machinery/system to have undertaken an independent risk assessment. Furthermore, the manufacturer must on this basis have prepared operating instructions for the overall machine/system.



These assembly instructions do not serve as replacement of the operating instructions of the overall machine/system.

2.2 Intended use

The product is a hydraulic control block. It is intended for use in industrial machines only. You may use the product as follows:

- for the control of a lower piston die cushion in hydraulic or mechanical presses according to EN ISO 16092
- in accordance with the application and environmental conditions according to the data sheet 63129
- in accordance with the specified performance limits according to the system-specific circuit diagram and according to data sheet 63129
- using in the original state (apart from system-specific settings) and/or without damage

The press module type IH04E is technical equipment and not intended for private use.

Intended use includes having read and understood this documentation, especially chapters 2 "Safety instructions" and 3 "General information on damage to property and damage to product".

2.2.1 Classification according to Directive 2006/42/EC

The press module type IH04E is a safety-related component intended only to be incorporated into or assembled with machinery or partly completed machinery to form, together with them, a machine within the meaning of Directive 2006/42/EC. The press module type IH04E is neither a machine, nor a safety component nor a partly completed machinery in terms of Directive 2006/42/EC - article 2.

The press module type IH04E may be commissioned only if it is integrated in the machine for which it is designed, and only if this machine fully complies with the basic safety and health requirements of Directive 2006/42/EC.

The area of application applies to hydraulic and mechanical presses according to EN ISO 16092-1, paragraph 3.1.

The press module type IH04E hydraulically controls the cylinder piston of a die cushion which is displaced by an upper die/punch according to EN ISO 16092-1, paragraph 5.3.1).

All operating modes according to EN ISO 16092-1 paragraph 5.4.2 and 5.3.2.1.h such as automatic mode, single stroke, jog mode as well as set-up and reliable slow closing velocity (<10 mm/s) are permitted. They operate according to a fixed working cycle specified in data sheet 63129.

The safety-related hydraulic control circuit with built-in valve position switches and direction control implements the safe operational stop or secure stop and has been designed for the following types of production:

- Single stroke: manual feed and sampling
- Automatic mode: manual feed and sampling
- Automatic mode: automatic feed and sampling

2.2.2 Limits of use

- ▶ Observe the operating conditions and performance limits specified in data sheet 63129.

2.3 Improper use

Any use deviating from the intended use is improper and thus not admissible.

Improper use of the press module type IH04E further includes:

- Use of the press module type IH04E for operation in explosive environments
- Use of the press module type IH04E under aggressive oder corrosive environmental conditions

Bosch Rexroth AG does not assume any liability for damage caused by improper use. The user assumes responsibility for all risks surrounding improper use.

2.4 Qualification of personnel

The activities described in this documentation require basic knowledge of mechanics and hydraulics as well as knowledge of the appropriate technical terms. In order to ensure safe use, these activities may only be carried out by an expert in the respective field or an instructed person under the direction and supervision of an expert.

Experts are those who can recognize potential dangers and apply the appropriate safety measures due to their professional training, knowledge and experience, as well as their understanding of the relevant conditions pertaining to the work to be undertaken. An expert must observe the relevant specific professional rules and have the necessary hydraulic expert knowledge.

Hydraulic expert knowledge means, among other things:

- Reading and completely understanding hydraulic circuit drawings,
- in particular, completely understanding the relationships regarding the safety equipment and
- having knowledge of the function and set-up of hydraulic components.



Bosch Rexroth offers training in specific fields. An overview of the training contents is available on the Internet via the following link:

www.boschrexroth.com/de/de/academy/.

2.5 General safety instructions

- Observe the valid regulations on accident prevention and environmental protection.
- Observe the safety regulations and provisions of the country in which the product is used/applied.
- Only use Rexroth products in technically perfect condition.
- Observe all notes on the product.
- Persons who assemble, operate, disassemble or maintain Rexroth products must not be under the influence of alcohol, drugs or pharmaceuticals that may affect their ability to react.
- Only use accessories and spare parts approved by the manufacturer in order to exclude any hazard to persons due to unsuitable accessories and spare parts.
- Comply with the technical data and environmental conditions specified in the product documentation.
- The installation or use of inappropriate products in safety-relevant applications could result in unintended operating states in the application, which in turn could cause personal injuries and/or damage to property. Therefore, only use a product for safety-relevant applications if this use is expressly specified and permitted in the documentation of the product, see chapter 4 "Scope of delivery", or if the safe suitability of the product in the application is confirmed by a separate conformity evaluation procedure for the end product, e.g. in explosion-protected areas or in safety-related parts of control systems (functional safety).
- Do not commission the product until you can be sure that the end product (for example a machine/system) where the Rexroth products are installed complies with the country-specific provisions, safety regulations and standards of the application.
- Never remove or damage lead seals that have been fitted at the factory.
- Ensure that all safety equipment included in the scope of delivery is present, has been installed properly and is functional. You must not suppress or disable position switches on the valve.

2.5.1 General safety instructions for press modules type IH04E

Pay particular attention to the hazards specified in par. 4 of EN ISO 16092 and EN 289 standards, such as:

- crushing and shearing between moving parts, such as tools, plungers, ejectors, or components attached to the lower die to perform special functions
- danger of entrapment (hazard due to being caught) in moving parts of the machine, separating protective devices, motor and drive machinery, mechanical handling equipment
- ejection of machine components

Pay attention to the main hazard zones specified in par. 4 of EN ISO 16092 and EN 289 standards, such as:

- die area with moving parts
- mechanical handling devices

The installation of the press module type IH04E is only admissible if a leakage velocity of 5 mm/s is not exceeded when opening the measuring port on the load-supporting side.

For hydraulic presses according to EN ISO 16092-3 and use of a PLC for valve monitoring, the PLC must meet the specification profile (such as SRP/CS) according to EN ISO 13849-1 PL "e" (category 4).

For maintenance and repair, the user must additionally ensure a mechanical restraint device between the tools, see EN ISO 16092, 5.3.6 and/or EN 289, 5.4.1.1.3.

For hydraulic presses according to EN 289 with a depth of the clamping plate greater than 800 mm and stroke greater than 500 mm, a mechanical restraint device according to EN 289, 5.4.1.1.3. is required.

2.6 Product- and technology-dependent safety instructions

The following safety instructions apply to chapters 6 to 9.

WARNING

Uncontrolled moving parts due to incorrect control and unexpected start-up when safety functions are bypassed or functional safety is not observed!

Danger to life! Risk of injury! Danger of entanglement, ejection or crushing of persons!

- ▶ Note the requirements of EN ISO 13849 as well as the relevant product standards EN ISO 16092 and EN 289 when setting up functional safety.
- ▶ Mount EMERGENCY stop devices, a safety door, light barriers, light curtains and/or two-hand control device.
- ▶ Immediately replace defective safety-related components.

Leakage of (pressurized) hydraulic fluid and oil mist!

Danger to life! Risk of injury! Explosion hazard, risk of fire, health hazard, environmental pollution! Damage to property!

- ▶ Switch the machine/system off immediately (emergency off switch).
- ▶ Identify and remedy the leakage.
- ▶ Never try to stop or seal the leakage or the oil jet using a cloth.
- ▶ Avoid direct contact with the leaking hydraulic fluid.
- ▶ Use your personal protective equipment, e. g safety goggles.
- ▶ Do not use the press module type IH04E in areas with open fire (e.g. ignition sources ...) and only at a sufficient distance to hot heat sources.
- ▶ When dealing with hydraulic fluids, you must implicitly observe the information of the hydraulic fluid manufacturer.

 **WARNING**

Unexpected press movements due to functional failures (overheating of the solenoid coil, drift error in the integrated electronics of proportional valves) of the press module type IH04E when the intended maximum temperatures are exceeded!

Danger to life! Risk of injury! Damage to property!

- ▶ Only use the press module type IH04E within the approved environmental and hydraulic fluid temperature range.

Rapid aging of seals and permanent leakage of valves when the press module type IH04E is used outside the approved temperature range!

Danger to life! Risk of injury! Damage to property!

- ▶ Only use the press module type IH04E within the approved hydraulic fluid temperature range.
- ▶ In case of leakage, immediately replace damaged seal rings and/or the affected valve.

Resonance or fluid noise, e.g. loud whistling and vibrations in case of unfavorable arrangement of the press module type IH04E in the press!

Danger of hearing damage! Material damage to the valves!

- ▶ Wear ear protection.
- ▶ In this case, contact a service engineer.

 **CAUTION**

Hot surfaces at press modules type IH04E, e.g. at valves and valve solenoid coils!

Risk of burning!

- ▶ Avoid contact with the press module type IH04E during operation.
- ▶ Only touch the surfaces of the press modules type IH04E with heat-resistant protective clothing, e.g. gloves, or do not work at hot surfaces.
- ▶ Allow the valves to cool down sufficiently before touching them.
- ▶ Observe the protective measures of the system manufacturer.
- ▶ If necessary, attach protective covers.

 **CAUTION**

Contact with hydraulic fluid!

Health hazard/impairment of health, e.g. eye injuries, skin lesions, poisoning due to inhalation and swallowing!

- ▶ Avoid contact with hydraulic fluids.
- ▶ When dealing with hydraulic fluids, you must implicitly observe the safety instructions of the hydraulic fluid manufacturer.
- ▶ Use your personal protective equipment, e. g safety goggles.
- ▶ If however hydraulic ... fluid comes into contact with the eyes or enters the bloodstream or is swallowed, consult a doctor immediately.

Slip hazard due to oily surfaces!

Risk of injury!

- ▶ Protect and mark the danger zone.
- ▶ Immediately remove leaked hydraulic fluid.
- ▶ Use an oil binding agent in order to bind the leaked hydraulic fluid.
- ▶ Remove and dispose of the contaminated oil binding agent, see chapter 8 "Disposal".
- ▶ Wear the protective equipment, e.g. safety shoes, prescribed for your activity.

Improperly laid pipes, hoses and cables!

Risk of injury! Risk of stumbling!

- ▶ Lay pipes, hoses and cables so that no-one can trip over them.
- ▶ Fasten cables and lines in order to prevent them from getting loose due to vibrations.
- ▶ Do not assemble hydraulic hoses close to heat sources.

Malfunction or unexpected system movements due to functional failures, e.g. jamming of valve spools, leakage in poppet seats or clogging of nozzles, due to contaminated hydraulic fluid!

Risk of injury!

- ▶ Comply with the cleanliness classes required in the relevant data sheet.
- ▶ If necessary, flush the hydraulic system for commissioning.

2.7 Personal protective equipment

During maintenance work as well as during installation and removal of the press module type IH04E, always wear the following personal protective equipment:

- Heat- or cold-resistant protective gloves
- Ear protection
- Safety shoes
- Perfectly fitting safety goggles
- Protective helmet

2.8 Information of the machine manufacturer

The machine manufacturer must provide the following information:

- The intended use for which the machine is designed
- The frequency of inspection and functional testing of the non-separating guards and the indicators
- The necessary maintenance of the guarding
- The procedures required for maintenance and/or repair, especially if guarding has been rendered ineffective
- A list of safety-relevant components, which must not be modified or replaced by the machine end-user
- The intervals for the replacement of safety-relevant components
- The frequency of checking for external leakage
- The frequency and procedure for testing the function of the hydraulic system to detect internal leakages
- The maximum weight and the maximum dimensions of the tools which may be used for the press

2.9 Obligations of the machine end-user

The machine end-user of the press must provide training for personnel on a regular basis regarding the following subjects:

- Observation and use of the machine manufacturer's operating instructions and the legal regulations
- Observation of the intended operation (incl. maintenance) of the press module type IH04E
- Observation of factory security officers' instructions and operating instructions of the machine end-user
- Behavior in case of emergency
- Effects of an emergency stop, how to free a person who has become entrapped in the die area, in particular as a result of bypassing or misuse of the safety equipment or after an emergency stop has been triggered, see EN 289, par. 7.2.3

3 General information on damage to property and damage to product

The following information applies to chapters 6 to 9:

NOTICE

Impermissible mechanical load due to impact or shock forces on assembled valves!

Damage to property!

- ▶ Do not place/put the press module type IH04E on the attachment parts (e.g. valves).
- ▶ Never use the assembled valves as a handle or step.
- ▶ Do not place/put any objects on top of the press module type IH04E.

Contamination of the hydraulic fluid by fluids and foreign particles!

Early wear and malfunctions! Damage to property!

- ▶ It is imperative that the working environment at the site of installation is free of dust and foreign substances in order to prevent foreign particles (e.g. welding beads or metal chips) from getting into the hydraulic lines and causing wear or malfunctions at the press module type IH04E.
- ▶ Make sure that all connections, hydraulic lines and attachment parts (e.g. valves) are clean and free of chips.
- ▶ For removing lubricants or any other contamination, use industrial residue-free wipes.
- ▶ No contamination must enter when closing the connections.
- ▶ Before commissioning, ensure that all hydraulic connections are tight and that all seals and caps of the plug-in connections are correctly installed and undamaged in order to prevent fluids and foreign particles from penetrating the press module type IH04E.

Mixing hydraulic fluids!

Damage to property!

- ▶ Generally avoid any mixing of hydraulic fluids of different manufacturers and/or of different types of the same manufacturer.
- ▶ Check the compatibility of the various hydraulic fluids and their compatibility with the components and seals. Mixing of hydraulic fluids may occur for example due to hydraulic fluid residues in a component.

NOTICE

Improper cleaning!

Damage to property!

- ▶ Cover all openings with the appropriate protective fittings / plugs / protective caps in order to prevent cleaning agents from penetrating the system.
- ▶ Check that all seals and electric plug-in connectors are firmly fitted to prevent the penetration of cleaning agents.
- ▶ Do not use aggressive and/or easily inflammable cleaning agents for cleaning. Clean the product using a suitable cleaning liquid and residue-free industrial wipes.

Leaking or spilled hydraulic fluid!

Environmental pollution and contamination of the ground water!

- ▶ Immediately remedy possible leakage.
- ▶ If hydraulic fluid is spilled, use an oil binding agent.
- ▶ Observe the information in the safety data sheet of the hydraulic fluid and the system manufacturer's provisions.

Environmental pollution caused by incorrect disposal!

Environmental pollution! Damage to property!

- ▶ Dispose of the press module type IH04E, the hydraulic fluid and the packaging in accordance with the applicable national regulations in your country.
- ▶ Dispose of the hydraulic fluid according to the applicable safety data sheet of the hydraulic fluid.

ONLY FOR ELECTRIC COMPONENTS!

Uncontrolled disconnection and connection of plug-in connectors!

Damage to property!

- ▶ Before installation works, separate the device from the mains or from the voltage source or de-energize it.
- ▶ Do not plug in or pull off the electric plug-in connector as long as the voltage supply is activated.

4 Scope of delivery

In addition to the order-related press module type IH04E, the scope of delivery consists of the general documentation and the product-specific documentation.

Table 5: Scope of delivery of the documentation¹⁾

	Document number	Title	Contents
General documentation	63124-B	General operating instructions for press modules	<ul style="list-style-type: none"> • General safety instructions • General product description • Work tasks performed by personnel • Transport and storage • Assembly • Commissioning • Operation • Maintenance and repair • Decommissioning • Disassembly and replacement • Disposal • Troubleshooting
	63129-MON (this document)	Type-specific assembly instructions for the press module type IH04E	<ul style="list-style-type: none"> • General safety instructions • Type-specific product description • Description of safety-relevant components • System design and installation • Error detection • Commissioning • Troubleshooting
Product-specific documentation	63129	Type-specific data sheet for the press module	<ul style="list-style-type: none"> • Limits of use • Hydraulic power • Functional description, cycle diagram and circuit diagram
	Order-related	Hydraulic circuit diagram	<ul style="list-style-type: none"> • Technical items • Connection designation and size • Solenoid switching sequence • Safety-related information
	Order-related	Parts list	<ul style="list-style-type: none"> • Material number • Type designation • Technical item • Data sheet number of valves
	Order-related	Installation drawing	<ul style="list-style-type: none"> • Drawing number with index • Dimensions • Position of the valves • Position of connection ports • Mounting surface • Weight

¹⁾ For further information on the applicable documentation, see chapter 1.2 "Required and additional documentation".



The warranty only applies to the delivered configuration. The claim to warranty expires if the product is assembled, commissioned and operated incorrectly, not used as intended and/or handled improperly.

5 Product information

5.1 Product description

The press module type IH04E is a hydraulic control manifold according to EN ISO 4413:2010, paragraph 5.4.4.3, comprising:

- A basic module .100
- A safety-related hydraulic control including a directional valve .110
 - against unintended closing movement of the plunger according to category 4 (EN ISO 16092:2018)
 - in accordance with general design principles of EN ISO 13849-1:2015
 - performance level validated to EN ISO 13849-2:2012
- Optional attached and/or separate extension module .105
- Attached extension modules .230 and .270

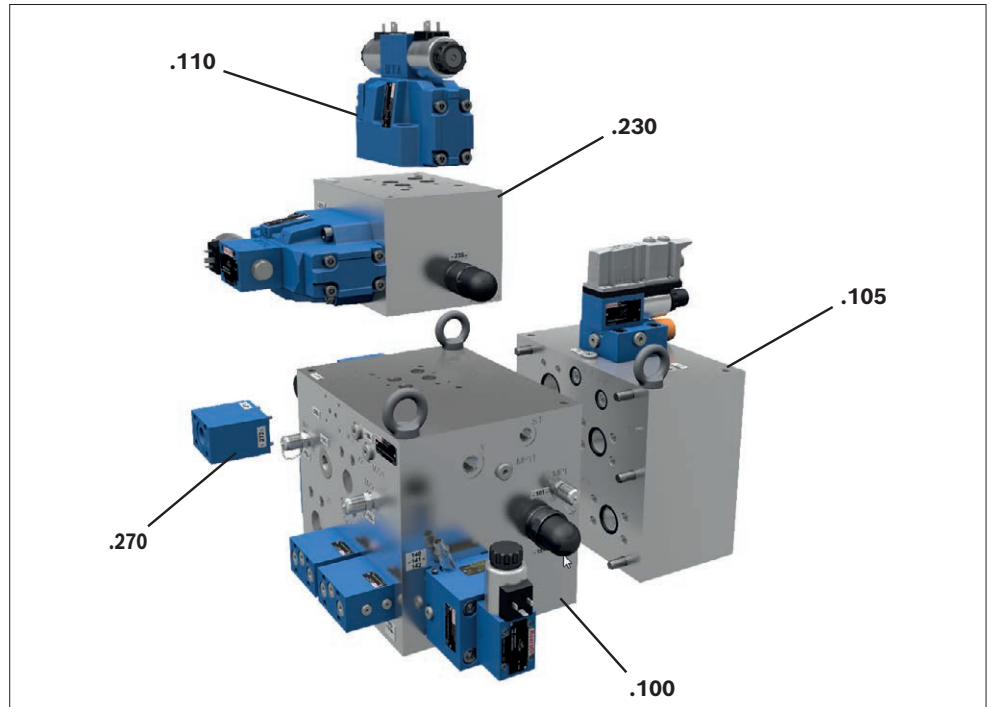

Fig. 1: Main components of the press module type IH04E

5.2 Description of safety-relevant components

5.2.1 Functional safety for hydraulic presses

A press module type IH04E consists of at least one basic module 100 and a directional valve .110, in order to avoid the mechanical hazards in the tool area with category 4 and PL e according to EN ISO 16092-1:2018 and 2:2020 or 3:2018.



The safety-related functions are part of the basic design and do not influence the set-up of the additional extension modules.

Table 6: Safety-related functions

Safety measures on the mechanical hazards	Normative reference	PL according to ISO13849	Safety category
Avoidance of unintended lowering by own weight	EN ISO 16092-3:2018, paragraph 5.3.7.2	e	4
Avoidance of unintended start-up from the rest position	EN ISO 16092-1:2018, paragraph 5.4.1.1.4 a)	e	4
Stopping of the dangerous closing movement	EN ISO 16092-1:2018, paragraph 5.4.1.1.4 c) EN ISO 16092-2:2020, table 1 EN ISO 16092-3:2018, table 1	e	4
Safe reduced velocity below 10 mm/s	EN ISO 16092-1:2018, paragraph 5.3.2.1 h) EN ISO 16092-3:2018, table 1 EN ISO 16092-3:2018, appendix F, F.3 example 2	d	3

5.2.2 Application example

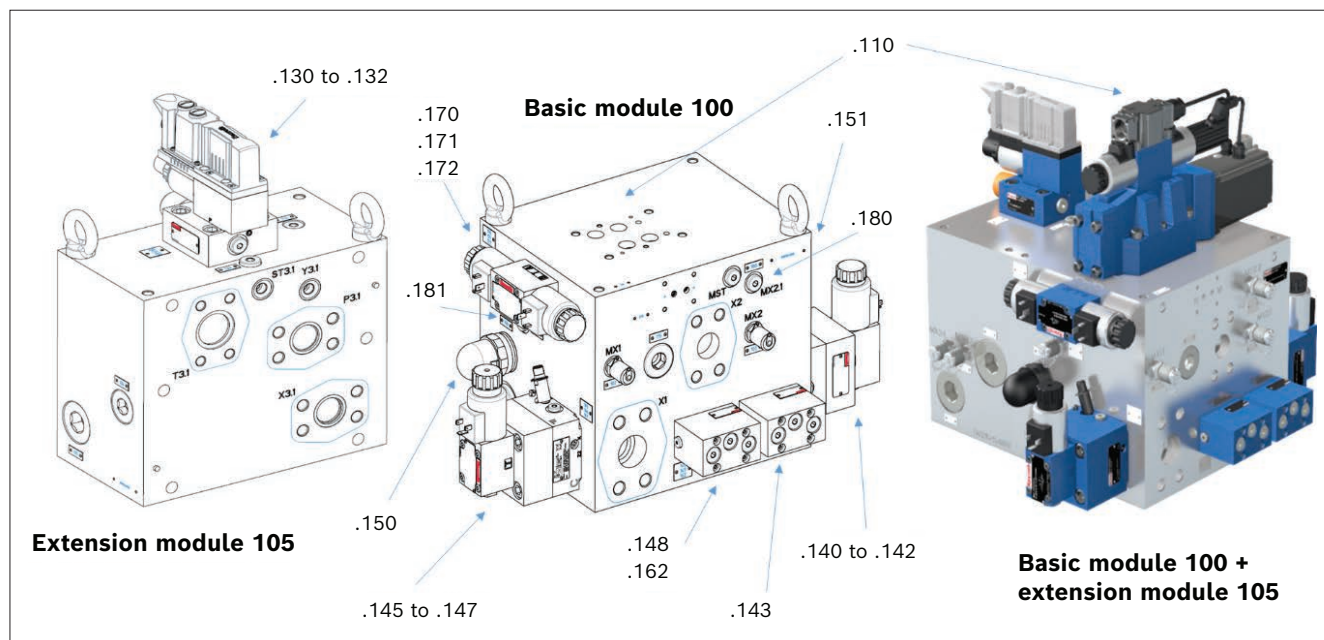

Fig. 2: Example: IH04ES-10/16G2-NEND-RTE220E-NN-G24

Table 7: Example:**Functions of the press module IH04ES-10/16G2-NEND-RTE220E-NN-G24**

Techn. item	Denomination	Function	Features
.110	Directional valve	Direction control of the cylinder piston	Not safety-relevant; On/off valve (passive only) Prop/high-response valve (passive and active)
.130/.131	Pressure function of cartridge valve	Main stage for drawing force (pressure) adjustment on the piston chamber side; max. operating pressure adjustment	Not safety-relevant; for further information on the cartridge valve, refer to data sheet 21050, see chapter 1.2 "Required and additional documentation".
.132	Proportional pressure relief valve	Proportional drawing force (pressure) adjustment	Not safety-relevant; pressure-controlled; direct operated; for further information on the pressure relief valve, refer to data sheet 29262, see chapter 1.2 "Required and additional documentation".
.140/.141	2-way cartridge valve, actively controllable	Second safety channel: Restraint device between piston chamber side and tank, energy separation	Position-monitored S140; for further information on the 2-way cartridge valve, refer to data sheet 21040, see chapter 1.2 "Required and additional documentation".
142	Directional valve	Pilot valve for the second restraint device	Spool valve
143	Supply nozzle	Flow limitation for the pilot control valve .143	0.8 mm
.145/.146	2-way cartridge valve, actively controllable	First safety channel: Restraint device between piston chamber side and tank, energy separation	Position-monitored S145; for further information on the 2-way cartridge valve, refer to data sheet 21040, see chapter 1.2 "Required and additional documentation".
.147	Directional valve	Pilot valve for the first restraint device	Seat piston valve
.148	Supply nozzle	Flow limitation for pilot valve .147	0.8 mm
.150/.151	Pressure relief valve	Pressure limitation against pressure intensification on the piston chamber side; The pressure relief valve must be set and sealed by the specialist in accordance with EN ISO16092-3, paragraph 5.2.3.6, to the required pressure (at least 10% above operating pressure).*	Direct operated; for further information on the pressure relief valve, refer to data sheet 25402, see chapter 1.2 "Required and additional documentation"; *only safety-relevant for dangerous downward movement; In the condition as supplied, the valve is set to 350 bar and sealed. Changes may only be made by accordingly qualified personnel.

Techn. item	Denomination	Function	Features
.162	Supply nozzle	Flow limitation for pilot valve .147	0.8 mm
.170	Directional valve	Direction control of the cylinder piston for slow velocity setup (<10 mm/s)	For further information on the directional valve, refer to data sheet 23178, see chapter 1.2 "Required and additional documentation".
.171	Discharge/supply nozzle	Flow limitation on the piston chamber side	0.8 mm
.172	Discharge/supply nozzle	Flow limitation on the annulus area side	0.8 mm
.180/.181	Nozzle	Flow limitation on the piston chamber side and annulus area side (<5 mm/s)	0.8 mm .180 not safety-relevant

5.3 Product identification

The press module type IH04E can be identified by its name plate.

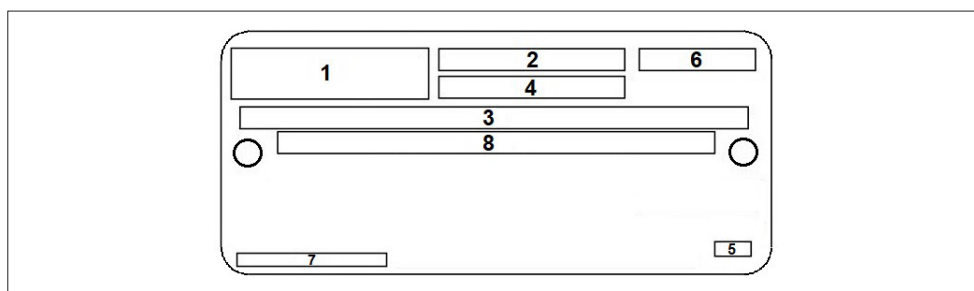

Fig. 3: Schematic illustration of a name plate

- | | |
|------------------------------|-----------------------------------|
| 1 Manufacturer's logo | 5 Area / works number |
| 2 Material number | 6 Date of production |
| 3 Type designation | 7 Designation of origin |
| 4 Serial number | 8 Customer material number |

6 System design and installation

WARNING

Unintended downward movement due to oil loss through measuring point MX1, MX1.1!

Danger to life! Risk of injury!

- ▶ Stay away from the danger zone if a hose or the like is attached to measuring point MX1, MX1.1.
- ▶ After using the measuring point MX1, MX1.1, carefully check that it is tightly closed and that the protective cap is reassembled.

Unintended downward movement due to oil loss through cylinder seals, valves and fittings!

Danger to life! Risk of injury!

- ▶ Ensure that the retraction of the cylinder in the standstill does not exceed 1 mm/s in normal operation and 5 mm/s in the event of component failure.
- ▶ Always keep the time spent in the danger zone as short as possible.
- ▶ Always use a mechanical restraint device for all work.



For information regarding the installation into the overall machine/system, particularly regarding its overall function and logical mode of operation, please refer to the operating instructions of the machine manufacturer. For additional information on how to prepare and execute the installation, refer to operating instructions 63124-B, see chapter 1.2 "Required and additional documentation".

6.1 Installation conditions and position

- ▶ During installation, always observe the environmental conditions such as the temperature range and operating parameters such as the hydraulic fluid, filtration, voltage and operating pressure specified in data sheet 63129, see chapter 1.2 "Required and additional documentation".
- ▶ It is imperative to provide for absolute cleanliness. Contamination of the hydraulic fluid may considerably impair the life cycle of the hydraulic component.
- ▶ Provide measures to prevent slipping on leaking hydraulic fluid, e.g. non-slip floor, drip pan.
- ▶ Select the installation position according to your technical requirements.
 - Overhead installation is excluded.
 - Install the press module type IH04E horizontally and with the directional valve .110 at the top.
 - Select the installation position so that the installation, repair, disassembly and adjustment of valves is possible without problems.
 - Assemble the press module type IH04E as close to the cylinder as possible.
 - Position or house the press module type IH04E in such a way that hazards due to liquids spraying out under high pressure are avoided. Ensure that the X1 line is as short as possible.

6.2 Safety equipment

In order to implement the required safety-related functions, safety equipment, for example a light curtain, is required. The safety equipment shall also comply with the requirements of the relevant standards, such as EN ISO 13849 and 16092, and possibly other applicable standards.

6.3 System design

6.3.1 Limitation of the operating pressure

- ▶ For modules without extension module .105, provide a separate external limitation of the maximum operating pressure.

6.3.2 Design of pressure relief valves .150/.151

- ▶ Ensure that the pressure relief valves .150/.151 are not actuated at maximum operating pressure on the ring side together with maximum own weight.
- ▶ Set the pressure relief valves .150/.151 and any pressure relief valves mounted externally to the connection port DB at least 10% higher than the normal maximum operating pressure and secure them against adjustment if downward movements must be safely prevented.
- ▶ Ensure that the cylinder and piping on port X1 can withstand the set pressure (EN ISO 16092-3, par. 5.2.3.3).



The setting must not exceed 350 bar.

6.3.3 Prevention of access in the danger zone

- ▶ Ensure that during a motion, access is prevented in the danger zone, i.e. the safety equipment remains active.



The hydraulic control does not emit a reliable (alone sufficient) muting signal with respect to the direction of movement or velocity of a die cushion controlled by it.

An exception to this is set-up with safe reduced velocity and hold-to-run control device.

6.3.4 Leakage through the safety-relevant valves .140, .142 and .170

- ▶ Ensure that leakage through the safety-relevant valves .140, .142 and .170, when in a safe (rest) position, does not cause any motion faster than 1 mm/s.
 - Design the system accordingly depending on cylinder dimensions, own weight and system pressure.

6.3.5 Reaction time (response time) of stop function

- ▶ Measure the reaction time (response time) of the stop function on the machine and calculate the minimum safety distances (see EN ISO 16092-1 appendices C and D, EN ISO 16092-2 appendices B and D and EN ISO 16092-3 appendices B, C and E).

6.3.6 Protection class

- ▶ Design your system/electrical connections for the IP65 protection class.

6.3.7 Dimensioning of nozzles .143, .148 and .181

- ▶ Dimension the nozzle .143 so that in the event of an error on the check valve .144, a cylinder velocity of >5 mm/s is prevented.
- ▶ Dimension the nozzle .148 so that in the event of an error on pilot valve .147 or check valve .144, a cylinder velocity of >5 mm/s is prevented.
- ▶ Dimension the nozzle .181 so that in the event of an error on the threaded coupling MX1 (or connected hose, pressure gauge or similar), a cylinder velocity of >5 mm/s is prevented.



During initial commissioning, the respective nozzle must be adapted if necessary.

6.3.8 Piping between cylinder piston side and port X1

- ▶ Ensure that the piping between the cylinder piston side and port X1 meets the requirements of EN ISO 16092-1, paragraph 5.2.1.7, e.g. fixed piping without compression connectors and hoses, if downward movements must be safely prevented.

6.3.9 Using the connection port DB

- ▶ Connect only one additional pressure relief valve to the pressure relief port.



Use of the connection port DB for other purposes is improper use.

- ▶ Ensure that additional external pressure relief valves on this port meet the requirements of EN ISO 16092-3, paragraph 5.2.3.3 and the piping of the external valves meets the requirements of EN ISO 16092-1, paragraph 5.2.1.7, e.g. fixed piping without cutting-ring connectors and hoses.

6.3.10 Interaction with other functions

- ▶ Consider possible interactions with other functions.

6.4 Electrical control system

In order to realize the required safety functions, a safe electrical control system is furthermore required. The safe electrical control system must also meet the requirements of the relevant standards, e.g. EN ISO 13849 and 16092, and possibly other applicable standards.

The safe electrical control system must ensure the functions described in the following sections.

6.4.1 Safe separation from the energy supply

- ▶ Ensure that the solenoids of the valves .142, .147 and .170 are safely separated from the energy supply when a cylinder motion would be dangerous.

6.4.2 Emergency stop

During operation

- ▶ Ensure that the solenoids of the valves .142, .147 and .170 are safely separated from the energy supply during the emergency stop.



In this case, Bosch Rexroth recommends that all other valve solenoids be de-energized.

In case of loss in the energy supply

- ▶ Ensure that an emergency stop is triggered when the energy supply is lost (electrical voltage supply, control voltage, hydraulic pressure supply or pilot oil supply).

This prevents an unexpected start when the energy supply is switched on again.

6.4.3 Safety-related function "Safe reduced velocity"

- ▶ For the safety-related function "Safe reduced velocity", ensure that the solenoid of the pilot valve .142 is disconnected from the power supply by a control with two monitored safety channels.

6.4.4 Evaluation of the limit switch signals of the monitored valves .140 and .145

- ▶ Ensure that the electric control system evaluates the limit switch signals of the monitored valves .140 and .145 to detect faults. This includes:
 - Testing of the correct function at least once per cycle
 - In case of a fault, triggering an emergency stop at the latest at the end of the cycle
 - Switching of the valves in automatic mode only if the danger zone is protected by the safety equipment.

6.4.5 Safety signals

- ▶ Ensure that safety signals are separate from other signals.



By separating the safety signals from one another, the protection against "common cause failure (CCF)" can be increased.

6.5 Fault detection

6.5.1 Control and evaluation of the limit switch signals



The machine manufacturer is responsible for providing appropriate control and evaluation so that all safety-relevant faults are detected in good time.

- ▶ Ensure that the limit switch signals are controlled and evaluated during the press cycle to detect safety-relevant faults in good time.



When applying EN ISO 13849, a DC value of 99% (tolerance 5%) must be achieved.

- ▶ Ensure that no new cycle or dangerous motion is initiated if one or more limit switch signals deviate from the expected state.
- ▶ Do not continue to operate the press until all faults have been corrected.
- ▶ Ensure that all safety-relevant valves in the standstill are in the safe position and that these are confirmed by the corresponding limit switch signals.

6.5.2 Malfunction caused by safety-relevant faults

The following malfunctions can be caused by safety-relevant faults which cannot be detected by the control and evaluation of the valve limit switch signals.



If one of these malfunctions is detected, the press must not be operated until all faults have been corrected.

Table 8: Malfunctions due to safety-relevant faults

No.	Malfunction	Possible cause(s)
1	<p>Slow lowering of the cylinder when safety-relevant valves are in the safe position.</p> <p>Notice: Some errors, such as contamination in the oil, leakage at the cylinder seals, can cause the cylinder piston to lower, which cannot be prevented by the hydraulic circuit. However, the circuit is designed in such a way that in the case of such errors in the press module type IH04E, the maximum volume flow due to leakage is limited - the worst case corresponds to a 0.8 mm nozzle. The resulting cylinder velocity depends on the cylinder load and annulus area and is normally less than 5 mm/s.</p>	<ul style="list-style-type: none"> • Leakage at cylinder seals or piping/fittings • Leakage at pressure relief valve .150/.151 • Leakage at valves .142, .144, .147, .149 • Leakage at threaded coupling MX1 • Crack in the manifold
2	<p>Slow start-up of the cylinder when safety-relevant valves are in the safe position.</p>	<ul style="list-style-type: none"> • Leakage at valves .144, .149

7 Commissioning

WARNING

Leakage of hydraulic fluid due to incorrectly mounted press module type IH04E!

Danger to life! Risk of injury!

- ▶ Only commission your machine/system after all hydraulic connections and the press module type IH04E have been completely and properly mounted according to the specifications.
- ▶ Look out for defective sealing points and replace defective seal rings immediately.
- ▶ Wear personal protective equipment during the initial commissioning.

Bursting of the press module type IH04E or ejection of the cap elements due to inadmissible operating pressure!

Danger to life! Risk of injury! Danger of bursting!

- ▶ Before commissioning the hydraulic system, ensure that the maximum admissible pressure of the hydraulic components in the machine/system cannot be exceeded.
- ▶ Ensure that in your machine/system, the maximum admissible operating pressure is secured by means of pressure limitation equipment.

Unintended downward movement due to oil loss through measuring point MX1, MX1.1!

Danger to life! Risk of injury!

- ▶ Stay away from the danger zone if a hose or the like is attached to measuring point MX1, MX1.1.
- ▶ After using the measuring point MX1, MX1.1, carefully check that it is tightly closed and that the protective cap is reassembled.

Unintended downward movement due to oil loss through cylinder seals, valves and fittings!

Danger to life! Risk of injury!

- ▶ Ensure that the retraction of the cylinder does not exceed 1 mm/s in normal operation and 5 mm/s in the event of component failure.
- ▶ Always keep the time spent in the danger zone as short as possible.
- ▶ Always use a mechanical restraint device for all work.

NOTICE

Uncontrolled connection or disconnection of electrical component plug-in connectors!

Damage to property!

- ▶ Before installation works, separate the press module type IH04E from the mains or from the voltage source or de-energize it.
- ▶ Do not plug in or pull off the electric plug-in connector as long as the voltage supply is activated.

Wear and malfunctions caused by contaminated hydraulic fluid!

Damage to property!

- ▶ During commissioning, absolute cleanliness must be ensured.
- ▶ Make sure that the hydraulic system is only filled with a filtered hydraulic fluid.
- ▶ Ensure that no contaminations are able to penetrate when sealing the ports.



For commissioning of the press module type IH04E, always observe the operating instructions of the overall machinery/system.

General information

- ▶ Ensure that changes to the safety-relevant valves/nozzles, see chapter 5.2 "Description of safety-relevant components", are only made by accordingly qualified and experienced specialists and after consultation with the manufacturer.
- ▶ Ensure that nozzles are not changed after initial commissioning.
- ▶ Ensure that safety-relevant components, see chapter 5.2 "Description of safety-relevant components" are only replaced by valves of the same type.



For further information on replacing valves, see chapter 10.7 of the general operating instructions 63124-B, see chapter 1.2 "Required and additional documentation"

- ▶ Ensure that safety-relevant components, see chapter 5.2 "Description of safety-relevant components", are replaced before the specified period of use is exceeded, because the required reliability of the components is no longer guaranteed when these limits are exceeded and the performance level of the safety functions is no longer valid; in this case there is an increased probability of a dangerous failure.



For further information on the period of use of the components, refer to the associated data sheets, and on calculating the probability of a dangerous failure refer to data sheet 08012, for reliability characteristics MTTFD for functional safety according to EN ISO 13849, see chapter 1.2 "Required and additional documentation".

7.1 First commissioning

For commissioning, proceed as follows:

- ▶ Make sure that all hydraulic connections are closed and all electrical connections are connected.
- ▶ Immediately depressurize the machine/system if hydraulic fluid still leaks despite proper assembly.
- ▶ Commission hydraulic components only if they are fully installed.
- ▶ Allow the press module type IH04E with integrated electronics to acclimatize for some time prior to commissioning as the electronics might be damaged by the generation of condensed water.
- ▶ Electrical connections must be checked for proper condition by or under the guidance and supervision of a specialized electrician before the initial or any re-commissioning.
- ▶ Before switch on, check whether the protective grounding conductor of all electric devices is firmly connected according to the connection diagram.



When commissioning the press module type IH04E on a machine/system, first of all commission the electronics that might exist and then the hydraulics. When commissioning the electronics, the hydraulics (power unit, valve etc.) must be switched off in order to prevent damage of the hydraulic components caused by incorrect wiring and malfunctions of the electronics.



Ensure a mechanical restraint function between the tools (EN ISO 16092, par. 5.3) or move the cylinder piston to a fall-proof parking position if the safety equipment of the overall machine/system is not active during initial commissioning.

- ▶ Ensure that all pressure valves except the pressure relief valves .150/.151 are set during commissioning, as these are set to minimum in the condition as supplied.



Pressure relief valves .150/151 are pre-set in the condition as supplied to 350 bar and secured against unauthorized adjustment, see Table 7.

- ▶ To limit damage in the event of a malfunction, start the first movement attempts with the lowest possible pressure.

7.2 Bleeding the hydraulic system

- ▶ For bleeding the overall system, observe the operating instructions of the machine and/or system into which the press module type IH04E is installed.
- ▶ Switch the press module type IH04E several times under 50% of the operating pressure before placing it into full operation so that air which has remained in the press module type IH04E can exit.

Mechanical damage due to inadmissibly high acceleration of the hydraulic fluid and the valve spools is thus avoided and the life cycle of the press module type IH04E is increased.

7.3 Commissioning of the basic module .100 and extension module .105

7.3.1 General information

- ▶ Ensure that the specified protection and safety equipment is in place and functional at every stage of the life cycle, such as commissioning, cleaning, maintenance or repairing, as well as in every operating mode.



Suppression or bridging of the specified safety equipment or removal of the specified protection equipment is not admissible.

- ▶ Before commissioning, ensure that the "OFF" operating mode (EN ISO 16092-1, paragraph 3.4.1.1) is functional to prevent start-up or continuous operation.
- ▶ Ensure that the "UP/DOWN" jog mode (EN ISO 16092-1, paragraph 3.4.1.2 and EN ISO 16092-3, paragraph 5.5.1) is functional with a safe reduced velocity (less than 10 mm/s) and hold-to-run device via the on/off valve .170 and the retaining valves .145/.147.



The die cushion movement is triggered by the permanent operation of a control device by the operator.

- ▶ When closing/extending, ensure that the maximum pilot oil supply flow rate is limited via nozzle .171 if it is higher than the piston side flow rate at 10 mm/s.
- ▶ When opening/retracting, ensure that the maximum pilot oil supply flow rate is limited via nozzle .172 (only if downward movements must be reliably prevented) if it is higher than the ring side flow rate at 10 mm/s.
- ▶ Ensure that the ring side is filled sufficiently with hydraulic fluid during retraction to avoid cavitation.
- ▶ Ensure that the maximum flow rate of the pilot oil supply is sufficient and that the nozzle .172 is not too small.
- ▶ Check the nozzles .171 and .172 during commissioning and adjust them if necessary.
 - Check the nozzles by closing/extending with minimum load pressure and opening/retracting with maximum load pressure.
 - Then update the changed nozzle fitting in the technical documentation of the machine (hydraulic circuit diagram/parts list).



The load pressure is the sum of the weight of the die cushion and the lower tool relative to the effective piston chamber surface.

- ▶ Ensure that the test stroke/single stroke (EN ISO 16092, par. 3.4.1.3) is functional via the main hydraulic circuit (.110, .130/.135 and .145/.147).

Sequence:

After the start (e.g. via two-hand control device), a complete run of a working cycle takes place.

Depending on the design of the die cushion module, the velocity is determined either by the pump (passively) or the prop/high-response valve .110 (actively). Depending on the design, the drawing pressure and thus the drawing force are determined via the pressure relief valve .130/.132 or the prop/high-response valve .110 (actively).

- ▶ If necessary, adjust the pressure of the pressure relief valves .150/.151 and seal them again to prevent unauthorized adjustment.



The pressure relief valves .150/.151 are pre-set in the condition as supplied to 350 bar, see Table 7.

- Then update the setting in the technical documentation of the machine (hydraulic circuit diagram/parts list).
- Ensure that the cylinder and piping on port X1 can withstand the set pressure (EN ISO 16092-3, par. 5.2.3.3).
- Ensure that the setting is not higher than 350 bar.

7.3.2 Setting the maximum drawing/operating pressure .130 to .132 (extension module .105)



The pressure limitation protects the system from overload. For modules without extension module .105, a separate external limitation of the maximum operating pressure must be provided.

Proceed as follows to set the extension module .105:

- ▶ Connect a pressure gauge to measuring point MP1.
 - To do this, remove the protective cap at the measuring point MP1.
- ▶ Pull the connectors off the .110 directional valve to keep the valve in its basic position.
- ▶ Note that in the condition as supplied, the hexagonal grub screw of the pressure relief valve mounted in the logic cover .131 is unscrewed, i.e. minimum pressure adjustment.
- ▶ Ensure that the command value at the proportional pressure relief valve .132 is equal to or slightly higher than the maximum operating pressure to be set.
- ▶ Start the pump(s), which are now running in depressurized circulation via the cartridge valve with pressure function .130.
- ▶ Adjust the pump(s) so that the maximum operating pressure can be achieved, depending on the type of pump used and with minimum flow rate.

- ▶ Remove the protective cap and slowly turn in the hexagonal grub screw of the pressure relief valve mounted in the logic cover .131 clockwise until the pressure specified in the hydraulic circuit diagram of the machine is achieved.



The pressure must not exceed 315 bar.

- ▶ Tighten the lock nut of the pressure relief valve mounted in the logic cover .131 and replace the protective cap.
- ▶ Select the operating mode "OFF".
- ▶ Assemble the connectors to the directional valve .110 and tighten them.
- ▶ Remove the pressure gauge from measuring point MP1 and assemble the protective cap again.
 - Ensure that the measuring point MP1 is closed without leaks.



An increase in the operating pressure directly influences the required setting at the pressure relief valves .150/.151 against pressure intensification on the piston chamber side.

7.3.3 Setting the pressure limitation against pressure intensification .150/.151

The direct operated pressure relief valves .150/.151 are used as protection against pressure intensification in the piston chamber of the cylinder.



The pressure relief valves .150/.151 are pre-set in the condition as supplied to 350 bar, see Table 7.

- ▶ Set the direct operated pressure relief valves .150/.151 according to EN ISO 16092-3, paragraph 5.2.3.6 at least 10% above the maximum operating pressure and seal them afterwards if downward movements must be reliably prevented.

7.3.4 Safe reduced velocity (<10 mm/s) - replacement of nozzles .171 and .172



Safe reduced velocity is operated with the pilot oil supply on port ST.

The main pumps are not required.

When operating with a safe reduced velocity, the 2-way cartridge valve .140 must be closed and solenoid Y142 of the directional control valve (pilot valve) .142 must be de-energized.

The safe reduced velocity (<10 mm/s) is controlled by the valves .170 (Y17a) and .145/.147 (Y147), in order to enable the safety function "safe reduced velocity" up to PLd/category 3 according to EN ISO 13849.

Proceed as follows to set the safe reduced velocity (<10 mm/s):

- ▶ Connect a pressure gauge to measuring point MX1.
 - To do this, remove the protective cap at the measuring point MX1.
- ▶ Retract the die cushion cylinder to the end stop (end stop must be able to withstand the maximum cylinder force).
- ▶ Switch off the pumps and all valves.
- ▶ Ensure that the piston chamber pressure at the measuring point MX1 = 0 bar.
- ▶ If necessary, connect a suitable hose to the measuring point MX1 and discharge the hydraulic fluid into a suitable oil tray until the pressure has completely reduced.
- ▶ Relieve the annulus area of the cylinder, e.g. by manually actuating the B-side of the directional valve .110 in the parallel position.

The pressure is only released up to approx. 3 bar preload pressure of the tank line.

- ▶ Connect a suitable hose to the measuring point MX2 and discharge the hydraulic fluid into a suitable oil tray until the pressure has completely reduced.
 - To do this, remove the protective cap at the measuring point MX2.
- ▶ Connect a pressure gauge to the measuring point MX2 and ensure that the pressure at this measuring point is 0 bar.
- ▶ Remove the directional valve .170 as the nozzles .171/.172 are mounted directly below the valve.
- ▶ Adjust the nozzles .171/.172 to the safe reduced velocity (<10 mm/s), see chapter 7.3.1. Close/extend with minimum load pressure and open/retract with maximum load pressure.
- ▶ Reinstall directional valve .170.



For the tightening torque, refer to data sheet 23178, see chapter 1.2 "Required and additional documentation".

- ▶ Select the "DOWN" jog mode.
- ▶ Verify that the closing velocity is below 10 mm/s.
- ▶ Ensure that the pressure in the annulus area of the cylinder at the measuring point MX2 does not drop to zero during retraction (cavitation).
- ▶ Remove the pressure gauge from the measuring points MX1 and MX2 and reassemble the protective caps.
 - Ensure that the measuring points MX1 and MX2 are closed without leaks.
- ▶ Select the operating mode "OFF".

7.4 Commissioning of extension modules .230 and .270



For the pressure values, refer to the hydraulic circuit diagram prepared by the machine manufacturer, and for further information, see the data sheets in chapter 1.2 "Required and additional documentation".

7.4.1 Extension module .230 with regenerative circuit

Table 9: Extension module .230 with regenerative circuit

Techn. item	Denomination	Function	Features
230	Sandwich plate	Rapid traverse with regenerative circuit	-
231	Directional valve	Regenerative circuit On/Off	Pilot-operated, see data sheet 24751.
235	Pressure relief valve	Protection against overpressure	See data sheet 25402.

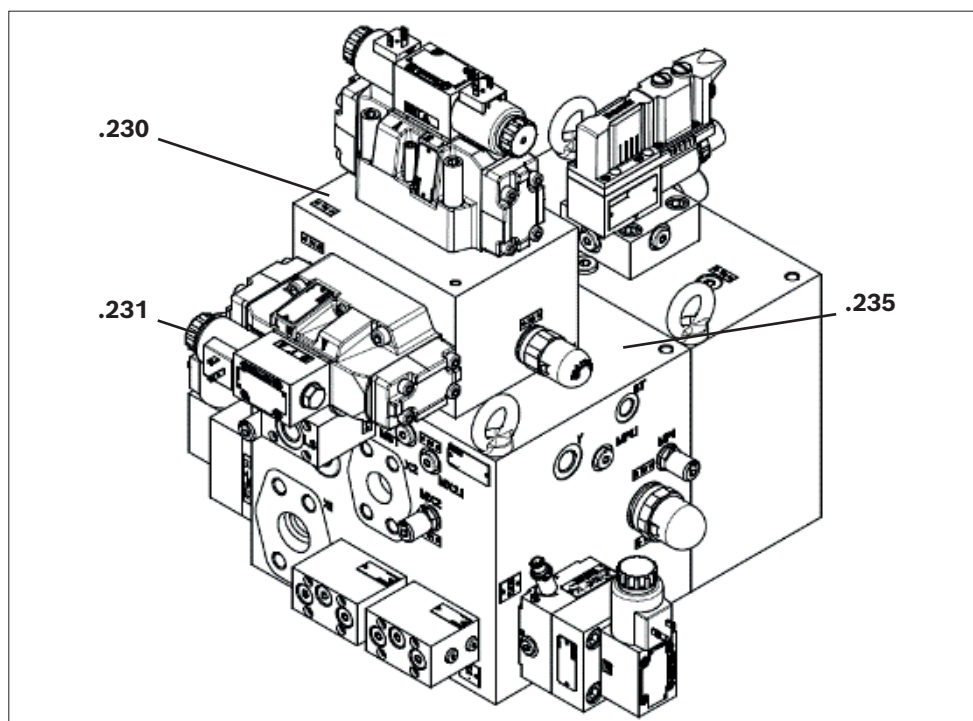

Fig. 4: Extension module .230 with regenerative circuit

To set the extension module .230 with regenerative circuit, proceed as follows:



In the condition as supplied, the hexagonal grub screw of the pressure relief valve .235 is set to minimum, i.e. minimum pressure adjustment.

The maximum operating pressure and the pressure limitation at the ring side have already to be set.

- ▶ Connect a pressure gauge to the measuring point MX2.
 - To do this, remove the protective cap at the measuring point MX2.
- ▶ Retract the cylinder until the end stop (end stop must be able to withstand the maximum cylinder force).
 - Remove the protective cap and, if necessary, slightly turn in the hexagonal grub screw of the pressure relief valve .235 clockwise until sufficient pressure is present.

The pressure on the ring side builds up to the pressure set at the pressure relief valve .235.

- Ensure that the command value at the proportional pressure relief valve .132 is equal to or slightly higher than the maximum pressure to be set.
- ▶ Adjust the pumps so that the maximum pressure to be set can be achieved, dependent on the type of pump used and with minimum flow rate.
 - Slowly turn in the hexagonal grub screw of the pressure relief valve .235 clockwise until the pressure specified in the hydraulic circuit diagram of the machine is achieved.
 - Ensure that the pressure is equal to or higher than the maximum drawing pressure and does not exceed 315 bar.
- ▶ Tighten the lock nut of the pressure relief valve .235 and put on the protective cap.
- ▶ Select the operating mode "OFF".
- ▶ Remove the pressure gauge from the measuring point MX2 and assemble the protective cap again.
 - Ensure that the measuring point MX2 is closed without leaks.

7.4.2 Extension module .270 with load sensing

Table 10: Extension module .270 with load sensing

Techn. item	Denomination	Function	Features
.270	Control plate	Load sensing function	-
.271	Nozzle	Limitation of flow from piston side	-
.272	Nozzle	Limitation of flow from ring side	-
.275	Shuttle valve	Determination of the pressure direction for load sensing	-

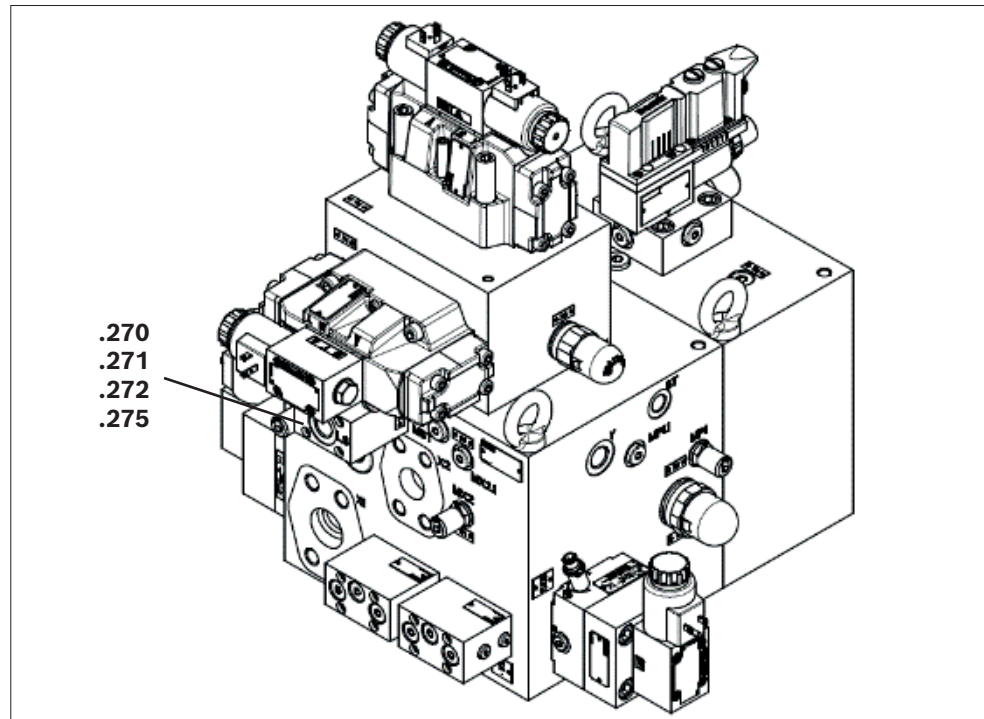

Fig. 5: Extension module .270 with load sensing

In order to use the load sensing function, you need a pump control with flow controller for your machine/system.

- ▶ Check the exact pump type.
- ▶ Please refer to the relevant data sheet for the correct setting of the pump.

7.5 Performing tests

If the downward movement must be safely prevented, then perform the following additional tests during commissioning and regular checking of the press:

Table 11: Required tests

No.	Component	Test
1	Leakage test valve .140	<ul style="list-style-type: none"> ▶ Hold the load with valve .145 open and without pump pressure. ▶ Measure the resulting velocity. <p>The maximum velocity should be <1 mm/s. If the maximum value is exceeded, the press must not be operated.</p>
2	Leakage test valve .145	<ul style="list-style-type: none"> ▶ Hold the load with valve .140 open and without pump pressure. ▶ Measure the resulting velocity. <p>The maximum velocity should be <1 mm/s. If the maximum value is exceeded, the press must not be operated.</p>



If the maximum values are exceeded during these tests, the press must not be put into operation or continue to be operated until the error is fixed.

Also check the following locations for leakage:

- Cylinder seals or piping/fittings
- Pressure relief valves .150/.151
- Threaded coupling MX1
- Crack in the manifold

8 Disposal

8.1 Environmental protection

- ▶ Careless disposal of the hydraulic components and the hydraulic fluid could lead to environmental pollution.
- ▶ Thus, dispose of the product and the hydraulic fluid in accordance with the currently applicable national regulations in your country.
- ▶ Dispose of hydraulic fluid residues according to the applicable safety data sheets for these hydraulic fluids.
- ▶ Please observe the following notices for the environmentally-friendly disposal of the hydraulic components.

8.2 Return to Bosch Rexroth AG

The hydraulic products manufactured by us can be returned to us for disposal purposes free of charge. There must be no inappropriate foreign substances or third-party components when products are returned. Hydraulic valves have to be drained before being returned. The components have to be delivered free to the following address:

Bosch Rexroth AG
Industrial Hydraulics Service
Bürgermeister-Dr.-Nebel-Straße 8
97816 Lohr am Main
Germany

8.3 Packaging

Upon request, reusable systems can be used for regular deliveries.

The materials for disposable packaging are mostly cardboard, wood, and expanded polystyrene. They can be recycled without any problems. Due to ecological reasons, disposable packaging should not be used for returning products to Bosch Rexroth.

8.4 Materials used

Hydraulic components from Bosch Rexroth do not contain any hazardous materials that could be released during intended use. Normally, no negative effects on human beings and on the environment are to be expected.

The press module type IH04E consists essentially of:

- Cast iron
- Steel
- Aluminum
- Copper
- Plastics
- Electronics components and assemblies
- Elastomers

8.5 Recycling

Due to the high metal content, hydraulic products can mostly be recycled. In order to achieve an ideal metal recovery, disassembly into individual assemblies is required. The metals contained in electric and electronic assemblies can be recovered by means of special separation procedures as well.

9 Troubleshooting



In addition to the safety-relevant errors in Table 8, Table 12 can help you with troubleshooting. This table is not exhaustive.

In practice, there may be problems that are not included here.

Further information on this topic is included in the respective product-specific documentation, see chapter 1.2 "Required and additional documentation".

9.1 How to proceed for troubleshooting

- ▶ Always work systematically and purposefully, even when under time pressure. Random, thoughtless disassembly and changing of settings might result in the inability to determine the original cause of error.
- ▶ First, get a general idea of the function of the press module type IH04E in connection with the overall machine/system.
- ▶ Try to find out whether the press module type IH04E has worked properly in conjunction with the overall machinery before the error occurred first.
- ▶ Try to determine any changes of the overall machine/system, in which the press module type IH04E is integrated:
 - Were there any changes to the application conditions or area of application of the press module type IH04E?
 - Has any maintenance work been performed recently? Is there an inspection or maintenance record?
 - Have modifications (e.g. refitting) or repair works been performed on the overall machine/system (machine/system, electrical system, control system) or the press module type IH04E? If yes: What were they?
 - Was the hydraulic fluid changed?
 - Was the press module type IH04E or the machine/system used as intended?
 - How did the fault become apparent on the control panel or visually on the press module type IH04E?
- ▶ Try to get a clear idea of the cause of error. If necessary, ask the actual (machine) operator.
- ▶ Document all work done.
- ▶ If you cannot remedy the error, please contact one of the contact addresses you find at www.boschrexroth.com or:

Bosch Rexroth AG
 Service
 Bgm.-Dr.-Nebel-Str. 8
 97816 Lohr am Main
 Phone +49 (0) 9352 - 40 - 50 60
service@boschrexroth.de

Table 12: Fault table

Malfunction	Possible cause
Drawing pressure not reached	<ul style="list-style-type: none"> • Maximum drawing pressure setting on the logic cover .131 too low. • Cable break at pilot valve .132. • Incorrect command value from the electric control system on pilot valve .132. • Pressure control via direction valve .110 not optimized. • Pressure relief valves .150/.151 set too low. • Pressure relief valve .235 set too low.
Drawing pressure too high	<ul style="list-style-type: none"> • Valve .140 and/or .145 does not open. Pressure relief valves .150/.151 are activated. • Incorrect command value from the electric control system to pilot valve .132. • Pressure control via direction valve .110 not optimized.
Cylinder piston remains in the lower position	<ul style="list-style-type: none"> • Pressure supply failure. • Pressure relief valve .130/.131 does not close and is stuck. • Pilot valve .132 does not switch or does not switch completely. • Maximum drawing pressure setting on the logic cover .131 too low. • Directional valve .110 does not switch. • Pressure relief valves .150/.151 not set.
Switching shock when starting a motion	<ul style="list-style-type: none"> • Switching time of directional valve .110 too fast. • Pump pressure too high.
Loud bang when driving against end stop	<ul style="list-style-type: none"> • Velocity too high. • Pump pressure too high.
Cylinder can only be driven in one direction	<ul style="list-style-type: none"> • Directional valve .110 stuck in a switching position.
Underpressure in the annulus area of the cylinder	<ul style="list-style-type: none"> • Tank preload pressure too low. • Nozzle .172 too small.
Safe reduced velocity <10 mm/s not working	<ul style="list-style-type: none"> • Nozzle .171/.172 blocked. • Directional valve .170 does not switch.
Safe reduced velocity (<10 mm/s) can only be driven in one direction	<ul style="list-style-type: none"> • Directional valve .170 stuck in a switching position.
Safe reduced velocity higher than 10 mm/s	<ul style="list-style-type: none"> • Nozzle .171 or .172 too large. • Nozzles set with incorrect own weight (closing/extending with minimum load pressure and opening/retraction with maximum load pressure).



In case of faults in individual components, please consult the documentation of the respective component.

10 Technical data



The admissible technical data of the respective press module type IH04E can be found in the respective data sheet, see chapter 1.2 "Required and additional documentation".

The data sheet can be found on the Internet at
www.boschrexroth.com/mediadirectory

For further information, refer to the online product catalog
www.boschrexroth.com

11 Alphabetical index

A			
	Abbreviations	7	
B			
	Bleeding the hydraulic system	31	
C			
	Commissioning	29	
	- Basic module .100 and extension module .105.	32	
	- Extension modules .230 and .270	36	
	Control and evaluation of the limit switch signals	27	
D			
	Damage to property	16	
	Design of pressure relief valves .150/.151	24	
	Dimensioning of nozzles .143, .148 and .181	25	
	Disposal	40	
	- Environmental protection	40	
	- Materials used	40	
	- Packaging	40	
	- Recycling	41	
	- Return to Bosch Rexroth AG	40	
E			
	Electrical control system	26	
	Emergency stop		
	- During operation	26	
	- In case of loss of the energy supply	26	
	Extension module .270		
	- with load sensing	38	
	- with regenerative circuit	36	
F			
	Fault detection	27	
I			
	Information of the machine manufacturer	15	
	Installation conditions	23	
	Installation position	23	
	Intended use	8	
	Interaction with other functions ..	25	
L			
	Leakage test valve .140	39	
	Leakage test valve .145	39	
	Leakage through the safety-relevant valves .140, .142 and .170	24	
	Limitation of the operating pressure	24	
M			
	Main components	19	
	Malfunction caused by safety-relevant faults	28	
O			
	Obligations of the machine end-user	15	
P			
	Personal protective equipment ...	15	
	Piping between cylinder piston side and port X1	25	
	Prevention of access in the danger zone	24	
	Product description	19	
	Product identification	22	
	Protection class	25	
Q			
	Qualification	10	
R			
	Reaction time (response time) of stop function	25	
	Required documentation	5	
	Risk classes according to ANSI Z535.6-2006	6	
S			
	Safe separation from the energy supply	26	

Safety equipment	24	Safety signals	27
Safety instructions	8	Scope of delivery	18
- General	11	Symbols	7
- Product- and technology- dependent	12	System design	24
- Signal word	6	T	
Safety-related functions		Technical data	44
- Avoidance of unintended lowering by own weight	20	Tests during commissioning	39
- Avoidance of unintended start-up from the rest position	20	Troubleshooting	42
- Safe reduced velocity ...	20, 26, 34	U	
- Stopping of the dangerous closing movement	20	Using the connection port DB	25

Bosch Rexroth AG

Industrial Hydraulics

Zum Eisengießer 1

97816 Lohr a. Main

Germany

Tel. +49 (0) 9352/40 30 20

my.support@boschrexroth.com

www.boschrexroth.com