

Less Emission, Lower Cost. Rexroth Hydrostatic Fan Drives

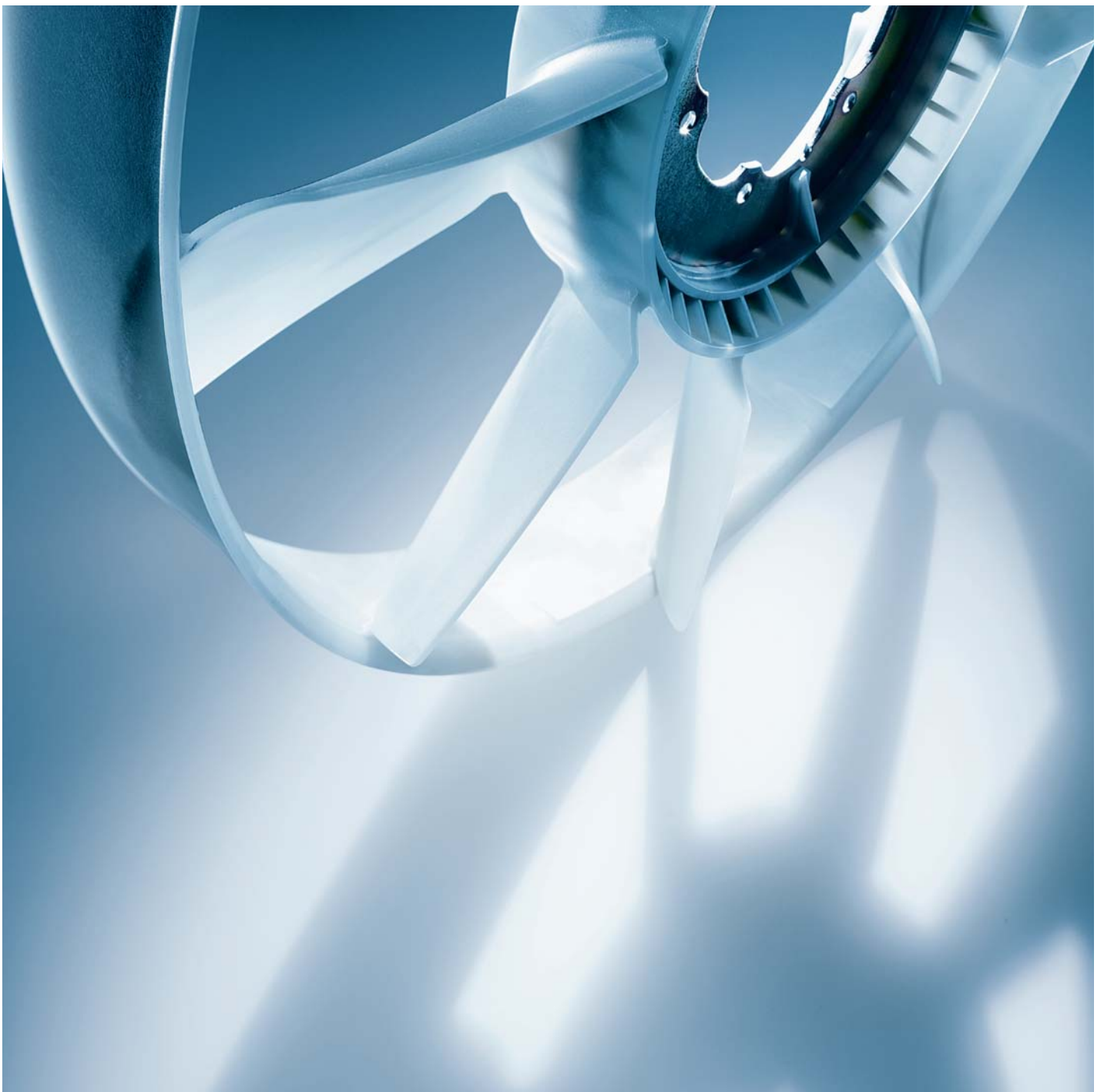

Optimum combustion temperature for a cleaner environment

The emission standards for commercial vehicles have been tightened worldwide and mandatory emission limits established. One thing necessary for achieving these values is an optimal combustion temperature for the engine, which in turn requires efficient cooling management. Required cooling capacity may increase by 15 to 40 percent related to the change-over to Euro 6 or TIER 4 final respectively. Moreover this results in about 20 percent higher space requirement for the radiator. Rexroth hydrostatic fan drives compensate for these changed conditions and play a significant role in modern engine systems.



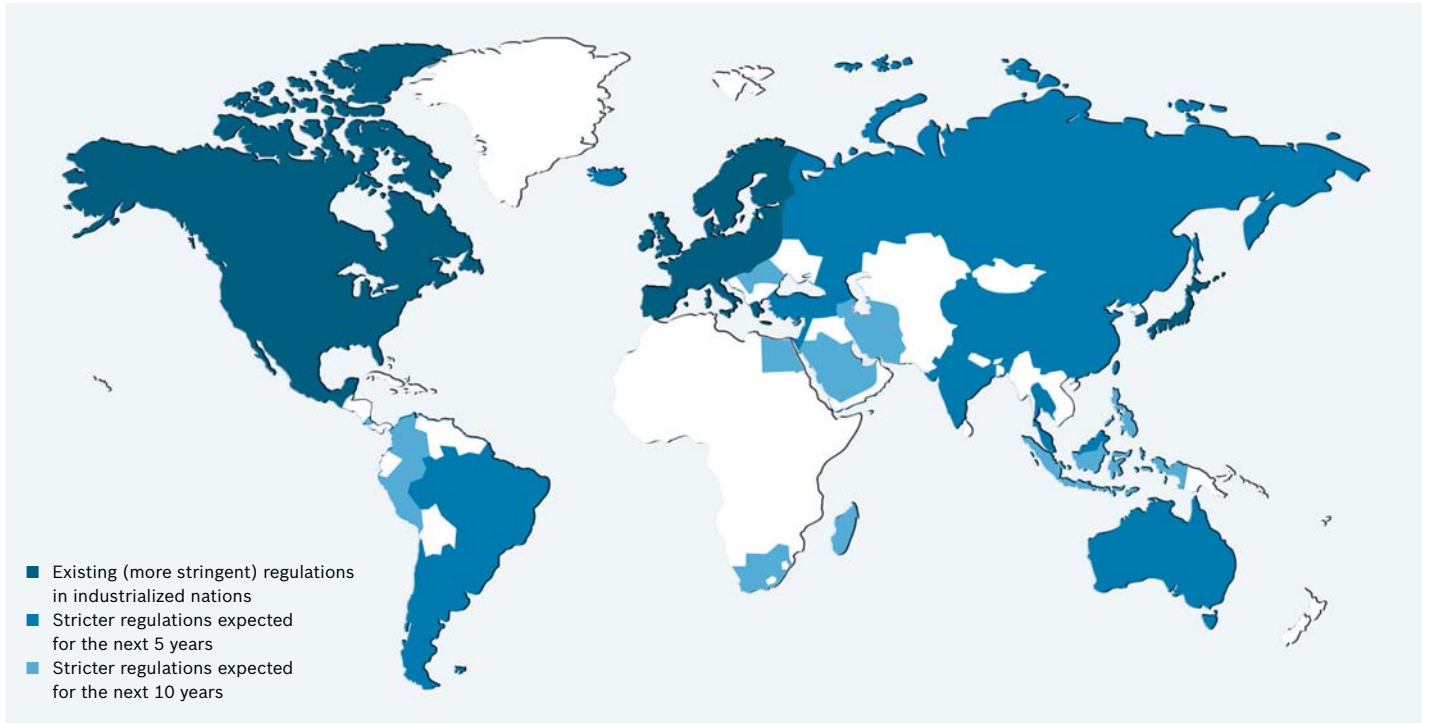

New emission legislation:

Hydrostatic fan drives play an important role

In order to meet today's exhaust and emission limits vehicle manufacturers are responding with alternative drive technologies which are operated in an ever narrowing temperature range and work using the maximum torque even at the lowest engine speeds.

Contributing to this are, above all, emissions-optimized diesel engines with particle filters and exhaust gas treatment systems. Alternative fuels such as CNG, LPG or Ethanol as well as alternative drive concepts like fuel cell technology, hydrogen fueled engines or hybrids are some other options. But in any case the demand on the fan system to provide the required cooling capacity for the modern drive technologies remains unaffected. And of course it needs to be as efficient and space-saving as possible. Both requirements are met using a modern controlled hydrostatic fan drive system with a variable axial pump.

▲ The world is moving closer together in terms of environmental protection

Legislations and directives governing the emission of pollutants from diesel engines are in force in many industrialized nations: Such as for carbon monoxide and dioxides, for sulfur and nitrogen oxides, for dust and soot. Further tightening of the limits is either concluded or already in planning. For example Euro 6 for on-highway vehicles and TIER 4 final for off-highway vehicles.

Experts anticipate that similar regulations and standards will be globally enforced with some delay. Thus the world will move closer together in terms of environmental protection.

For engine manufacturers, the challenge in meeting the standards is to reduce peak combustion temperatures, while further reducing the particle content of the exhaust gas. Rexroth hydrostatic fan drives make sure that the combustion process takes place at the optimum temperature – at all times.

The future of air movement lies with Rexroth hydrostatic fan drives

The task of a hydrostatic fan drive is to use controlled air movement to carry off the dissipated heat from the combustion engine arriving at the radiator. Here the drive serves to ensure optimal engine and combustion temperature. Intelligently controlled fan drive systems thereby help to maintain the legal emissions directives while saving energy. How? Controlled by highly developed sensors, they provide cooling based on the measured temperature to consistently reduce operating costs. No more or less cooling than needed – regardless of whether in on- or off-highway applications.

From sensors and controllers to pumps and motors, Rexroth offers the right fan concept for a wide variety of applications.



Axial-piston motor



External gear pump



Plastic tank



Axial-piston pump



BODAS application software



External gear motor

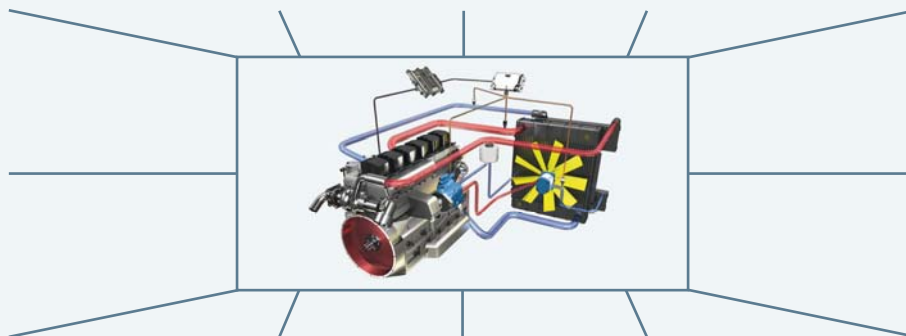

BODAS diagnosis software



Reversing valve



Thermal pressure valve



Valve module



BODAS temperature sensors



BODAS controller

The benefits of hydrostatic fan drives at a glance



Environment

- ▶ Meeting exhaust gas directives (Euro 4/5/6, TIER 4, US10, Stage IV...)
- ▶ Reduction in fuel consumption
- ▶ Reduced pollutant and noise emission

Costs

- ▶ Clear reduction in operating costs by up to 5 percent
- ▶ Long-lasting Rexroth components
- ▶ Higher efficiency compared with other fan drive technologies

Function

- ▶ Steplessly variable fan speed independent on the engine speed
- ▶ High fan power at low engine speeds
- ▶ Option for reverse fan function and standstill
- ▶ Flexible component layout
- ▶ Radiator assembly can be split
- ▶ Space saving

Energy

- ▶ Cooling on demand for reduced fuel consumption
- ▶ Additional fuel savings with fan stop option

Rexroth hydrostatic fan drives bring a breath of fresh air to every industry



Rexroth hydrostatic fan drives are used in a wide variety of applications – from agricultural and forestry equipment to construction machines and buses.



▲ **Blowing the air the other way: The reversing operation**

Temperatures are just one problem. The second problem is dust and dirt, which deposits itself inside the radiator, especially in the case of construction and agricultural machines. To prevent the cooling performance from deteriorating, engineers have come up with a smart solution – the reversing operation. The fan rotor direction of rotation changes at different intervals, so that air is blown in the opposite direction, carrying the dirt outside. The advantage of the reversing operation is obvious. The radiator remains unobstructed and the engine operates at ideal engine and combustion temperatures.



◀ **There are times when a fan is not needed:
The standstill option**

With the optional standstill feature, the fan rotor is completely shut down during the start-up phase or when ambient temperatures are very low. Thus the internal combustion engine reaches its operating temperature faster and the exhaust gas pollutants are optimally reduced. Moreover, the consumption-optimized standstill feature permits fuel savings of up to 1 percent compared to conventional fan standstill solutions.

Clear advantage for a hydrostatic fan drive

Today's combustion engines with their power and torque characteristics demand high cooling power even at low engine speeds. The tightened exhaust standards (Euro 6, US10, TIER 4 and Stage IV) also result in an increase in the space requirement for the radiator and fan by up to 15 percent. To offset this, a flexible arrangement of the radiator with respect to the engine is needed. By separating the combustion engine from the radiator, previously unused areas can now be optimally utilized.

Hydrostatic fan drive

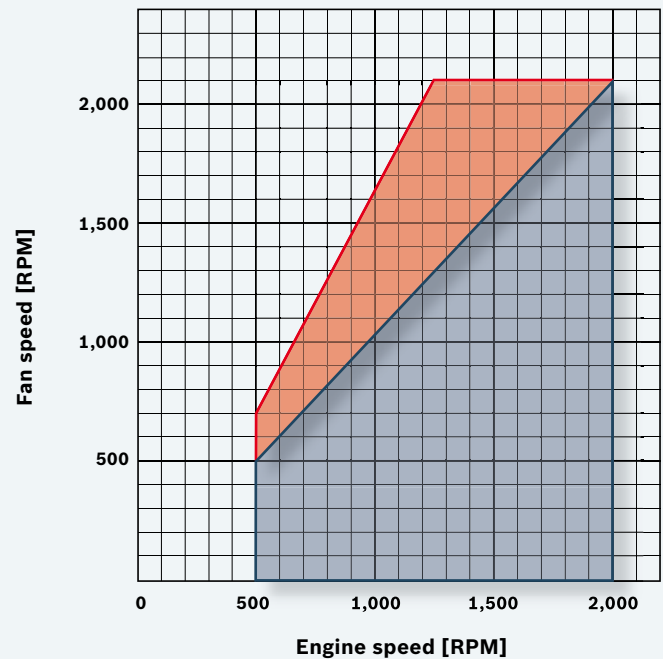
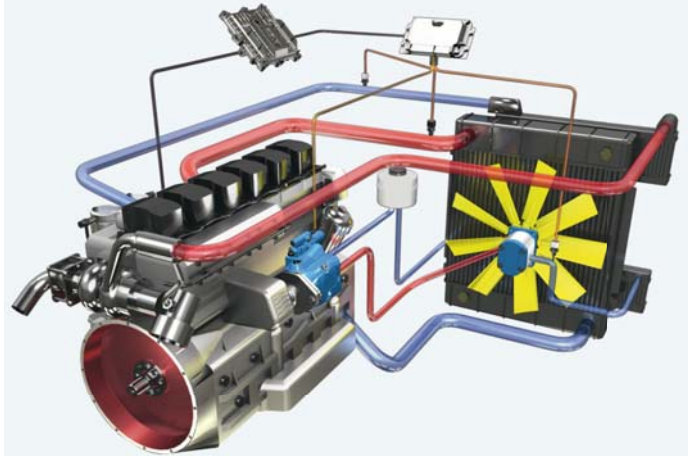

▲ Hydrostatic fan drive

- ▶ Fan speed decoupled from the engine speed
- ▶ Stepless (proportional) control of the fan speed
- ▶ Additional fan power at low diesel engine speed
- ▶ "Cooling on demand"
- ▶ Fuel savings of up to 5 percent
- ▶ Reduced noise levels
- ▶ Flexible layout of the system components
- ▶ Options for fan stop, reverse and splitting the radiator module

Mechanical drive

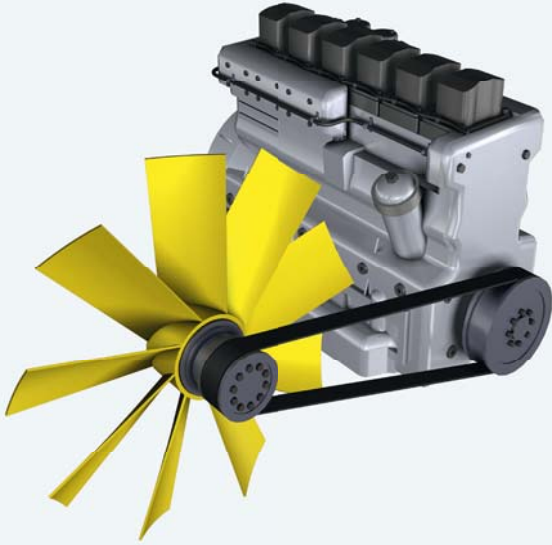

Electromagnetic clutch

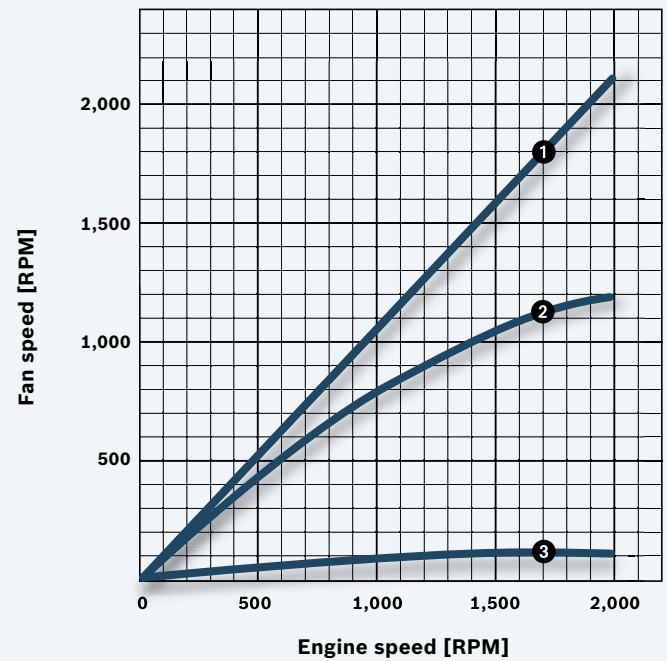
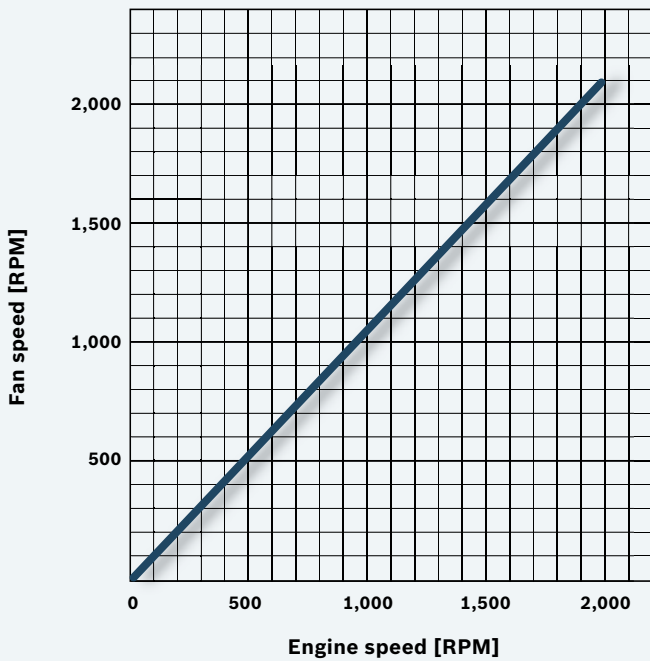
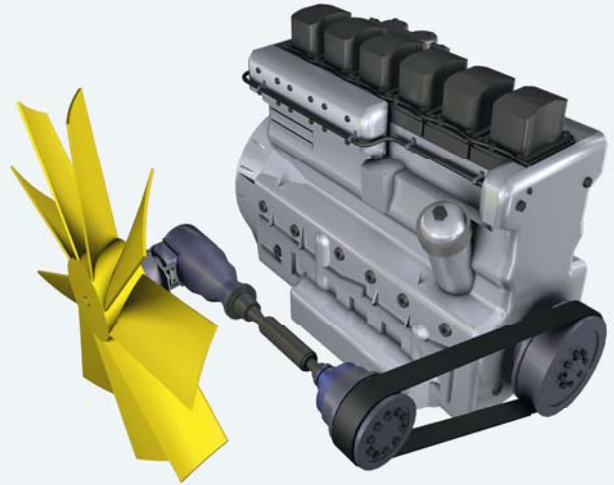

▲ Mechanical drive

- ▶ Fan speed directly dependent on engine speed
- ▶ Limited cooling power at low engine speeds
- ▶ Fixed arrangement of the radiator module
- ▶ Sub-optimal noise levels
- ▶ Cost-effective solution for low-cost countries

▲ Electromagnetic clutch

- ▶ Fan speed variable in three steps
- ▶ Limited fan output at low engine speeds
- ▶ Fixed arrangement of the radiator module
- ▶ Sub-optimal noise levels
- ▶ Cost-effective solution for low-cost countries

Hydrostatic fan drives: Controlled air movement pays

Cooling is always a technical challenge, since energy needs to be expended for already consumed energy in order to keep the engine and combustion temperature at the proper level. This is accomplished by efficiently dissipating the heat loss, which unfortunately always involves energy consumption and cost. Hydrostatic fan drives enable this expenditure to be precisely metered, since the fan output automatically varies exactly according to the measured temperatures. Compared with a mechanical fan drive system this saves up to 5 percent in fuel!



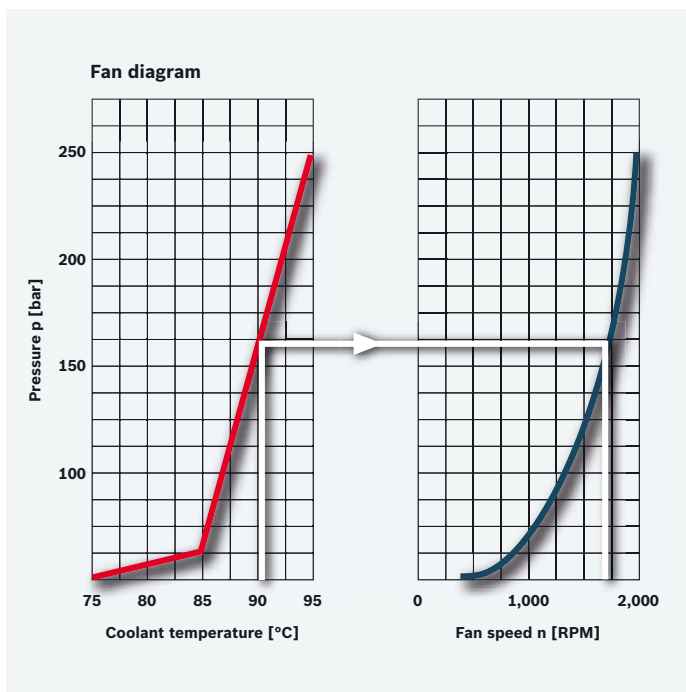

Continuously variable fan power – independent of engine speed

There is a sensible way of saving energy: Using only the amount of energy that is needed to achieve a desired condition. This calls, first and foremost, for flexibility. That is why Rexroth hydrostatic fan drives provide variable power continuously, depending on how much cooling is desired at any given time. The temperature is kept constant independently of the engine speed. Sensors measure the temperatures and control the fan performance.

This guarantees that the hydrostatic fan drives consume only the amount of energy that is actually required. This reduces the impact on the environment and saves operating costs compared to conventional fan systems.

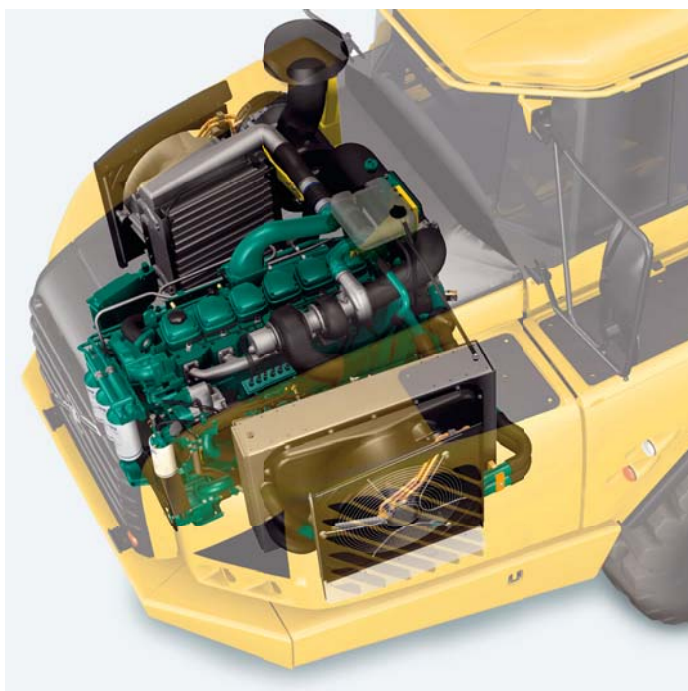

Flexible equipment assembly – more latitude in engine development

There is a limit to development in engine technology: the engine compartment. Rexroth hydrostatic fan drives give design engineers great latitude – within the bounds of the space available – in arranging the fan system and all its components. Hydraulic pumps, tubes, controllers and the radiator can simply be put where there is free space – the available space is efficiently utilized. This flexibility is a major advantage compared to direct drives using belts or drive shafts. For example, a roof cooling system of the type planned and already in use on modern buses is thus only possible together with a hydrostatic fan drive.

Thanks to this latitude, design and development engineers can focus all their attention on what is really essential: the engine and its performance.

Rexroth hydrostatic fan drives come in 2 x 2 variants

Rexroth hydrostatic fan drives are available in four different variants. For one, the fan drive can be hydraulically or electrically controlled. For another thing, the fan can be driven by a fixed or variable system. Which hydrostatic fan drive variant is the right one for you depends largely on how many operating temperatures need to be monitored and controlled – and on the engine power, of course. In any case, we can guarantee: The design and development engineers of Rexroth will support you in making the right choice from the outset of your project.

The first choice to be made:**Hydro-mechanically or electro-hydraulically controlled fan drive?**

The hydro-mechanical fan control system is used for relatively simple systems, i. e. applications where one or two temperatures at maximum need to be controlled. In modern vehicle technology, however, an increasing number of fluids and temperatures are controlled. This is necessary, for instance, where an exhaust gas recirculation system is used or where the diesel engine charging air needs to be cooled. To make sure that the different operating temperatures can be evaluated and weighted to guarantee correct fan operation, you need an electro-hydraulically controlled fan drive. The various signals are processed faster and more efficiently, while the quality of the control process improves – entirely independently of the engine power.

The BODAS controller from Rexroth minimizes the computational complexity involved in temperature evaluation. It can be connected to the CAN bus of the internal combustion engine, thus making additional temperature sensors superfluous.

The second choice to be made:**Constant gear pump or variable axial-piston pump?**

The fixed gear pump is used for small to medium fan drive powers (of up to approx. 15 kW). The constant gear pump and the constant gear motor featuring an integrated priority valve make sure that the pressure and flow necessary to remove the dissipated heat are always available at the fan motor. The priority valve can direct any excess flow to other hydraulic consumers. This type of hydraulically controlled fan drive saves between 10 and 20 percent energy compared to an uncontrolled fan drive system.

Axial-piston pumps are often used for higher fan drive powers (from approx. 10 kW upwards). These variable pumps supply the exact amount of oil that is needed for the desired fan speed. This means that the pump output is constantly adapted to match the required fan power. This reduces fuel consumption by up to 5 percent. One more advantage: With this system the oil coolers can be up to 70 percent smaller compared to a constant pump system.



Hydrostatic fan drives

Hydro-mechanical control system

Fixed system

- ▶ External gear pump
- ▶ External gear motor
- ▶ Thermal pressure valve
- ▶ Priority valve
- ▶ Hydraulic tank

- ▶ Can be used independently of the drive train (diesel engine, gas engine, fuel cell, etc.)
- ▶ Radiator is freely arrangeable
- ▶ Stepless fan speed control (independent of internal combustion engine speed)
- ▶ Low-weight pump and motor
- ▶ Short overall pump length
- ▶ Noise-optimized 'Silence Plus' gear pump
- ▶ Low acquisition cost

Variable system

- ▶ External gear pump
- ▶ External gear motor
- ▶ Thermal pressure valve
- ▶ Hydraulic tank

- ▶ Can be used independently of the drive train (diesel engine, gas engine, fuel cell, etc.)
- ▶ Radiator is freely arrangeable
- ▶ Stepless fan speed control (independent of internal combustion engine speed)
- ▶ Long service life
- ▶ Pump adapts itself to the required fan power (up to 5 % fuel savings compared to a fixed pump system)
- ▶ 50 to 70 % smaller oil cooler (compared to a fixed pump system)

Elektro-hydraulical control system

Fixed system

- ▶ External gear pump
- ▶ External gear motor
- ▶ Electronics/sensors
- ▶ Electronic pressure-relief valve
- ▶ Hydraulic tank

- ▶ Can be used independently of the drive train (diesel engine, gas engine, fuel cell, etc.)
- ▶ Radiator is freely arrangeable
- ▶ Stepless fan speed control (independent of internal combustion engine speed)
- ▶ Low-weight pump and motor
- ▶ Short overall pump length
- ▶ Noise-optimized 'Silence Plus' gear pump
- ▶ Low acquisition cost
- ▶ Several operating parameters are measured and weighted (which is relevant to compliance with emission levels)
- ▶ CAN bus connection

Variable system

- ▶ Axial-piston pump
- ▶ Axial-piston motor
- ▶ Electronics
- ▶ Temperature sensors
- ▶ Hydraulic tank

- ▶ Can be used independently of the drive train (diesel engine, gas engine, fuel cell, etc.)
- ▶ Radiator is freely arrangeable
- ▶ Stepless fan speed control (independent of internal combustion engine speed)
- ▶ Long service life
- ▶ Pump adapts itself to the required fan power (up to 5 % fuel savings compared to a fixed pump system)
- ▶ 50 to 70 % smaller oil cooler (compared to a fixed pump system)
- ▶ Additional fuel savings can be obtained with the optional fan standstill feature
- ▶ Several operating parameters are measured and weighted (which is relevant to compliance with emission levels)
- ▶ CAN bus connection

Hydrostatic fan drives with a variable pump: Less energy consumption and thus less emission

The comparison between a fan drive featuring a fixed pump and a system with a variable pump shows, in the case of a city bus: Fan drives with variable pumps consume less energy and thus reduce operating costs in the long term.



Application example: City bus fan

Key data

Maximum fan power:	12 kW
Lowest diesel engine speed, at which the maximum fan speed must be available:	1.400 RPM
Selected motor size:	14 cm ³
Selected pump size:	28 cm ³
Maximum pressure level of the system:	240 bar
Gear ratio i:	1

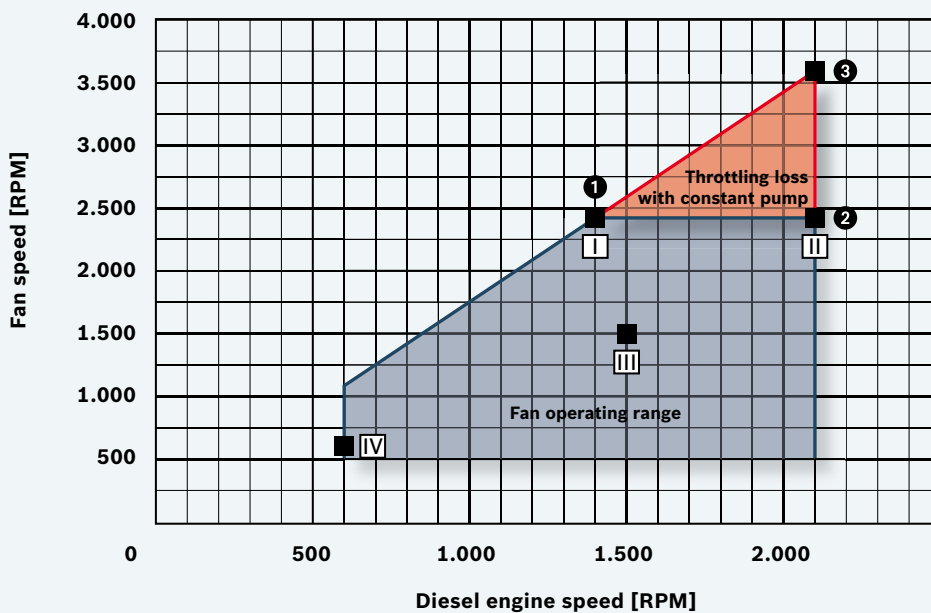

Design considerations

The motor size results from the maximum system pressure level and the fan power at maximum fan speed. The selection of the pump size is made based on the lowest diesel engine speed, at which the maximum fan speed must be available. Point ① is also the decisive factor in choosing between a constant and a variable pump. The farther to the left design point ① is located in the speed diagram, the higher the throttling loss with a fixed system. In line with this, the design points for the oil cooler for the variable system ② and for the fixed system ③ will change as well.

Operating cycle

	Engine speed	Fan speed	Duty cycle
Operating point I	1.400 RPM	2.400 RPM	3 %
Operating point II	2.100 RPM	2.400 RPM	2 %
Operating point III	1.500 RPM	1.500 RPM	65 %
Operating point IV	600 RPM	600 RPM	30 %

Energy balance (application example)

	Total power requirement (related to cycle)	Power savings (related to cycle)	Required oil cooler at design point	Max. Flow rate	Required tubing diameter	Required hydraulic oil tank
Constant pump	5,9 kW	0 kW	13,2 kW ③	55,8 l/min	100 %	100 %
Variable pump	3,5 kW	2,4 kW	5,1 kW ②	35,5 l/min	80 %	65 %

Recapitulation: The variable pump with integrated fan standstill function permits fan operation energy costs to be significantly reduced. Thus the higher initial cost of this system will be quickly recovered. Rexroth hydrostatic fan drives with variable pumps save up to 5 percent in fuel costs on a long-term basis.*

* The energy savings shown are dependent on the system design and may be higher or lower in actual operation.

Many components make up a system solution: The Rexroth hydrostatic fan drive

A fan drive system from Rexroth is made up mainly of proven standard components, supplemented with fan-specific special solutions and custom control software. As a result all the parts are in perfect harmony and can be matched to any requirements of the overall system.

Axial-piston pump



A10VO 28...85 ED/52
A10VO 28...85 DRG/52
Technical data sheet
RE 92 703

A10VSO 10 ED/52
A10VSO 10 DRG/52
Technical data sheet
RE 92 713

External gear pump



AZPF-22-004...028
AZPN-22-020...036
AZPG-22-022...056
Technical data sheets
RE 10 089, RE 10 091,
RE 10 093
AZPS-22-004...028
Technical data sheet
RE 10 095

Axial-piston pump



A10VO 28...140 ED/31
A10VO 28...140 DRG/31
Technical data sheet
RE 92 701

A10VSO 18 ED/31
A10VSO 18 DRG/31
Technical data sheet
RE 92 712

External gear pump Silence Plus



AZPJ-22-012...028
Technical data sheet
RE 98 243

Axial-piston pump



A11V(L)O 190...260/11
Technical data sheet
RE 92 500

External gear motor



AZMF-22-008...022
Technical data sheet
RE 14 026

Option:
integrated DSM speed sensor
Technical data sheet
RE 95 132

Axial-piston motor

A10FM/E 10...63/52
 Technical data sheet
 RE 91 172

Option:
 integrated DSM speed sensor
 Technical data sheet
 RE 95 132

Plastic tank

TMP
 Technical data sheet
 RE 95 721

Axial-piston motor

A2FM 5...1000/6
 Technical data sheet
 RE 91 001

Option:
 integrated DSM speed sensor
 Technical data sheet
 RE 95 132

BODAS temperature sensors

**TSA for air,
 TSF for fluids respectively**
 Technical data sheets
 RE 95 180
 RE 95 181

Reversing valve

LF1 / LF2
 Technical data sheet
 RE 18 305-04

BODAS controller

RC2-2
 Technical data sheets
 RE 95 201
 RE 95 202
 RE 95 203

Thermal pressure valve

MHDBDT
 Technical data sheet
 RE 64 309

BODAS application software

AFC
 Technical data sheet
 RE 95 360

Valve module

Technical data sheet
 Upon request

BODAS PC diagnosis tool

Technical data sheet
 RE 95 086

Laying out your hydrostatic fan drive: in good hands at Rexroth



Professional, individual consultation and comprehensive service offering are our strengths. Thanks to many years of experience, the intimate industry knowledge of our specialists and the trustful cooperation with our customers we are able to develop the ideal hydrostatic fan system for any application either on- or off-road. And that's not all: from startup to repair and spare parts service to our broad range of training courses – at Rexroth you experience expert, reliable advice and assistance.

Developing for tomorrow's demands today

The future is being mapped today. Playing a large role in this are the industry specialists at Rexroth. Their task is to analyze current and future customer requirements in the area of drive and control technology for the respective sector and to develop appropriate solutions. In the case of our fan drive this means the ideal Rexroth fan drive for every application in every sector.

System solutions from Rexroth: perfectly matched fan components

Future requirements for vehicles and machines can be summed up as follows: more powerful, faster availability, lower emissions and above all less expensive to operate. Thanks to broad industry knowledge and engineering know-how, modern simulation programs and high-performance testing equipment, we help to meet these requirements. Together with customers and partners we use a minimum of interfaces to develop complete, ready-to-use system solutions using perfectly matched components.

Focus on the future of the hydrostatic fan drive

Rexroth is continually developing our hydrostatic fan drives. Of particular importance is the question of which solutions can be implemented by a hydrostatic fan drive. At Rexroth we are already working on ways to combine the hydrostatic fan drive with additional functions. These include for example the air-conditioning compressor, the air compressor and other applications. Such combined systems are simple to realize using BODAS electronic controllers and software.

The goal: new combinations for greater energy savings and environmental protection

The advantages of these new combinations lie in optimal weight distribution and economy of space inside the machine. The bottom line is energy savings and protection of the environment. And last but not least, operating costs are reduced. Through such innovative development we are laying the foundation for the future success of our customers.

Service that sets standards

With our certified Rexroth service centers in over 40 countries we ensure that our customers always have direct local access anywhere in the world to our comprehensive service offering.

Rexroth service – simply convincing



◀ Service – Startup Support

To ensure that the crucial step of putting a newly developed system into operation is successful, we offer our customers a wide variety of comprehensive services:

- ▶ Installation support by specially trained field service personnel
- ▶ Comprehensive prototype testing
- ▶ Equipment startup
- ▶ Measuring and troubleshooting service



◀ Repair

The level and quality of after-sales services tell customers a lot – if not everything – about a system developer. We offer:

- ▶ Rapid and reliable repairs and modifications
- ▶ Worldwide network of modern repair workshops with qualified engineers and online access to the latest design data
- ▶ On-site repair by our field-technicians
- ▶ Warranty as for new parts
- ▶ Replacement system Reman



◀ Training and Consultancy

He who knows a lot, can do a lot – this statement sums up our program of basic and advanced training courses in mobile hydraulics.

At www.boschrexroth.com/mobil-seminars you will find our current offer of training courses.

▲ Spare Parts Service

This Rexroth service is known for its prompt and skilled response:

- ▶ Original manufacturers' spares
- ▶ Preassembled units and kits
- ▶ Efficient logistics worldwide
- ▶ Supply of spare parts even after series production has been discontinued

Bosch Rexroth AG

Mobile Applications
Glockeraustrasse 4
89275 Elchingen, Germany
Tel. +49 7308 82-0
Fax +49 7308 72-74
info.brm@boschrexroth.de
www.boschrexroth.com/brm