

D-28.22

- DWVPA-2 ... : with 8 bar hydrostat spring
- DWVPZ-2 ... : with 5 bar hydrostat spring
- Integral pressure relief function
- With damping orifice on port Z
- Pilot or drain to port B
- Good corrosion protection, stainless steel adjusting screw
- Available with line- and manifold mounting body type DD-12 (see data sheet G-24.21)

Bypass by-pass adjustable, 10 mm Sea e Pilot, Spool-type Main Stage

Series DWVPA-2 ... DWVPZ-2 ...
140 l/min, 315 bar



OIL SOLUTIONS

PO Box 38
Strathfieldsaye, VIC, 3551
1800 OIL SOL
1800 645 765
sales@oilsolutions.com.au
www.oilsolutions.com.au
"For All Your Hydraulic Needs"

DIMENSION

Adjuster style S

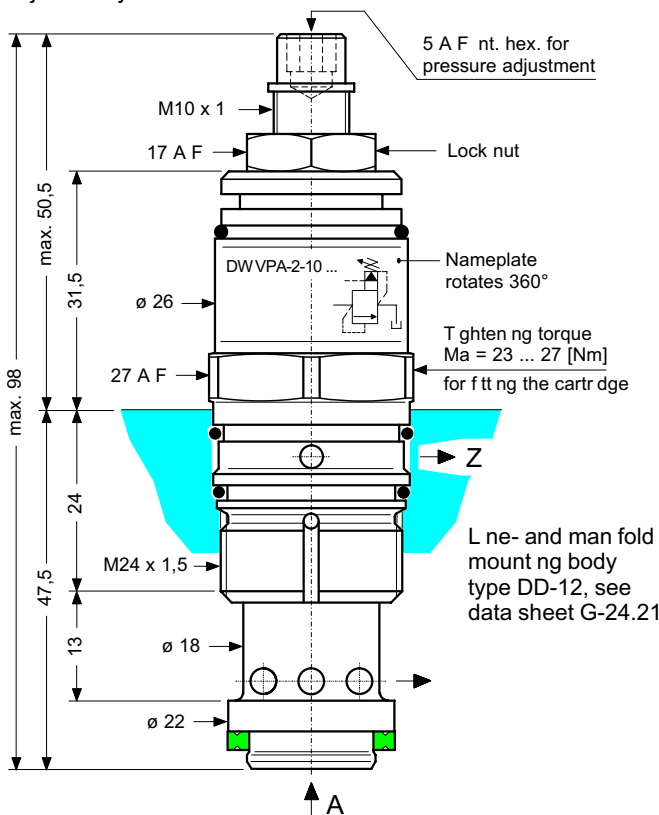

avi y type DD
see data sheet -45.2

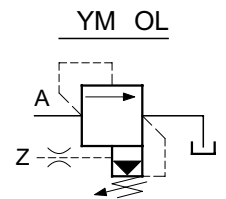

DWVPA-2-10 ...
DWVPZ-2-10 ...

AD U TER TYLES

Hydrostat cartridges can also be supplied with adjuster styles and 4 (see Model Code Key).

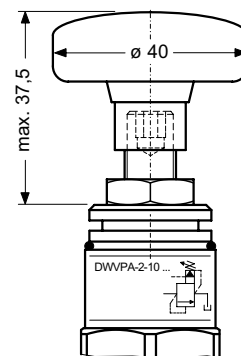

Adjuster style
Hand knob

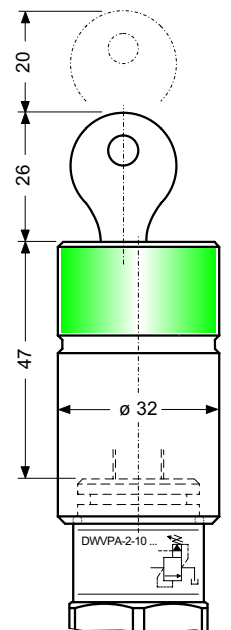

Adjuster style 4
Lockable hand knob
type 2H compl es w th
Volkswagen Factory
pec f cat on V 1.09

DE CRIPTION

Series DWVPA-2-10.. /DWVPZ-2-10.. cartridges are applied as bypass hydrostats in hydraulic circuits. Two fixed hydrostat springs are available, 8 bar (DWVPA ...) or 5 bar (DWVPZ ...).

The cartridges have an additional, integral, pressure relief function from A to . The orifice which is necessary for this relief function is already incorporated in the Z port of the cartridge, so it does not have to be designed into the block.

The cartridge has a seated pilot stage and a sliding spool-type main stage.

Pilot or drain with the valve to port , which should preferably be run direct to tank otherwise any pressure fluctuations will affect the valve setting by the same amount.

When the Z port is vented, the cartridge unloads port A to .

Form tools are available for sale or hire, should customers wish to manufacture their own blocks or subplates.

For direct pipe-mounted applications, the line- and manifold mounting body type DD-12 (G 1 2") can be used.

SCHEMATIC SECTION

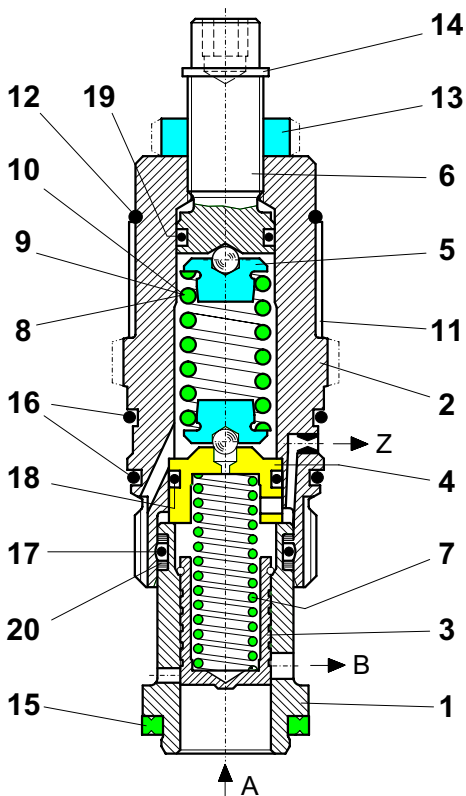

COMPONENTS / SERVICE PARTS

It.	Qty.	Description		
			*) = part of seal kit no. DS-216	
			▲ = available as service part	
1	1	Cartridge neck DWVPA	ø 21,9 x 30,5	
2	1	Cartridge head D2	ø 30 x 57	
3	1	Spool DWVPA	ø 12 x 17,4	
4	1	Ball seat	ø 15 x 10	
5	2	Ball holder, complete	ø 11 x 5,7	
6	1	Adjusting screw	ø 13 x 31	
7	1	Spool spring	1,4 x 8,7 x 36,4	iG = 14
8	1	Spring - pressure range N	2,1 x 12,0 x 21,0	iG = 6,5
9	1	Spring - pressure range M	1,9 x 11,6 x 21,0	iG = 7
10	1	Spring - pressure range L	1,5 x 10,8 x 21,0	iG = 8,5
11	1	Nameplate collar	ø 26 / 24 x 15	
12	▲	Snap ring	ø 24,7 x 1,6	
13	▲	Hex. nut	M10 x 1	DIN 439 B
14	▲	Circlip	ø 9	type SS
	1	Seal kit no. DS-216, comprising *):		
15	1*)	Seal	ø 22,1 / 16,5 x 2,5	
16	2*)	O-ring no. 020	ø 21,95 x 1,78	N90
17	1*)	O-ring	ø 14,00 x 2,00	N90
18	1*)	O-ring no. 013	ø 10,82 x 1,78	N90
19	1*)	O-ring no. 012	ø 9,25 x 1,78	N90
20	2*)	Backup ring	ø 18 / 15,2 x 1,2	

TO ORDER SERVICE PARTS, STATE:

- complete unit model code from the nameplate, including the design number
- data sheet number, including issue date
- part item number from above list
- part description from above list
- quantity required

INSTALLATION AND SERVICING

MUST BE CARRIED OUT WITH CARE, AND BY QUALIFIED PERSONNEL ONLY

When changing seals, the new seals should be thoroughly oiled or greased before fitting them to the valve.

Use the correct tightening torque when fitting the cartridge.

NOTE - before removing the cartridge from its cavity, and during the the whole time that it is not fitted in a cavity, the spring (item 8 ... 10) must be fully decompressed by turning back the adjusting screw (item 6), otherwise the cartridge neck will be pushed out of the cartridge head.

MAIN CHARACTERISTICS

Type	bypass hydrostat cartridge
Design	seated pilot stage, sliding spool main stage with remote control port Z
Mounting method	screw-in cartridge (M24 x 1,5)
Size	nom. 10 mm, cavity type DD
Mass	0,23 kg
Mounting attitude	unrestricted
Flow direction	A → B (see symbol)
Operating pressure	... 315 bar in A and B (... 315 bar in Z also)

Pressure adjust. range	pressure range N: 10 ... 315 bar pressure range M: 10 ... 210 bar pressure range L: 10 ... 65 bar
Fluids	hydraulic oils HL and HLP to DIN 51 524 other fluids by arrangement
Min. fluid cleanliness	18/14 to ISO 4406 / CETOP RP70H 8 ... 9 to NAS 1638
Fluid temperature range	-20° ... +60° C
Viscosity range	10 ... 300 cSt
Flow rate Q max. A → B	140 l/min
Flow rate Q max. attainable at the actuator	... 55 l/min with DWVPA-2 (Δp 8 bar) ... 45 l/min with DWVPZ-2 (Δp 5 bar)

PERFORMANCE DATA Oil viscosity 33 cSt

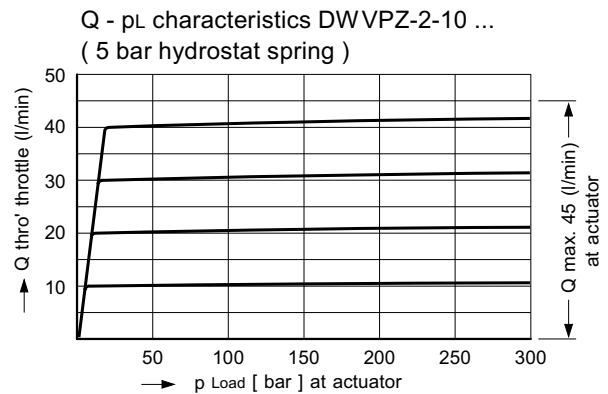
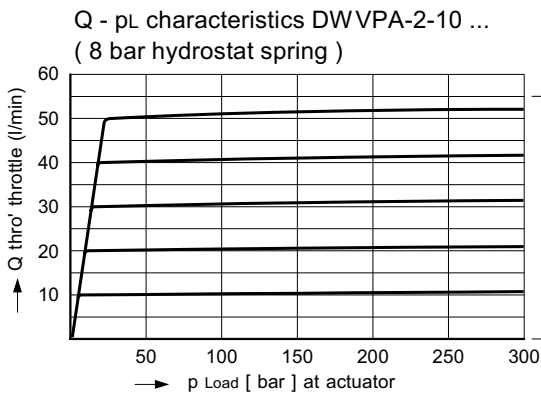
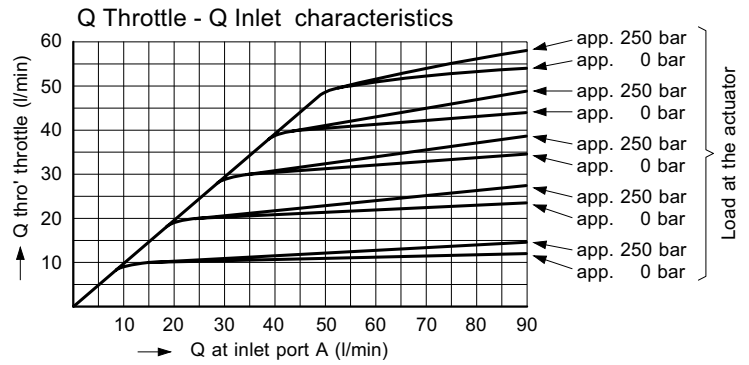
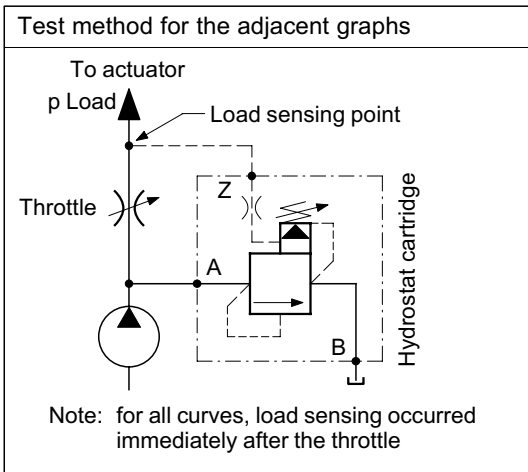

MODEL CODE KEY

- D = pressure control valve
- W = hydrostat
- V = two-stage
- P = cartridge design
- A ... Q = standard model per relevant data sheet
- Z ... R = special features by arrangement
- 2 = pressure control type 2 (with remote control port Z, pilot oil drained to port B)
- 10 = nominal size 10 mm
- S = with screw adjuster (standard)
- H = with hand knob adjuster
- Z = with lockable hand knob adjuster type Z4
- N = pressure range 10 ... 315 bar (Normal)
- M = pressure range 10 ... 210 bar (Medium)
- L = pressure range 10 ... 65 bar (Light)
- (blank) = Nitrile seals (standard)
- V = Viton seals
- S = special seals by arrangement
- 1 ... 9 = design number (omit when ordering new units)

Ex. D W V P A - 2 - 10 - S N - 1

RELATED DATA SHEETS

- i - 45.2 cavity type DD
- G - 24.21 Line- and manifold mounting body type DD-12 (G 1/2")

APPLICATION EXAMPLE

Typical manifold block for a load-sensing system with a constant delivery pump ('OPEN CENTRE'). The two-stage bypass hydrostat (BDWV) provides the following functions:

- main system pressure relief (315 bar).
- load sensing: the highest load pressure is fed back thro' the shuttle valves WV1 - WV5 and the pump operates at that pressure + Δp of 8 bar from the main stage of the hydrostat.
- unloading the system (approx. 8 bar)

The two cylinders Zyl. 1 and Zyl. 2 are required to operate together at different, but constant, speeds therefore the two inline hydrostats (IDW1 and IDW2) are provided.

The Δp between hydrostat and load sensing point can be set between 5 and 8 bar.

The speed of the cylinder Zyl. 1 is determined by the throttle Dü1, the maximum pressure by the pilot stage of the bypass hydrostat BDWV.

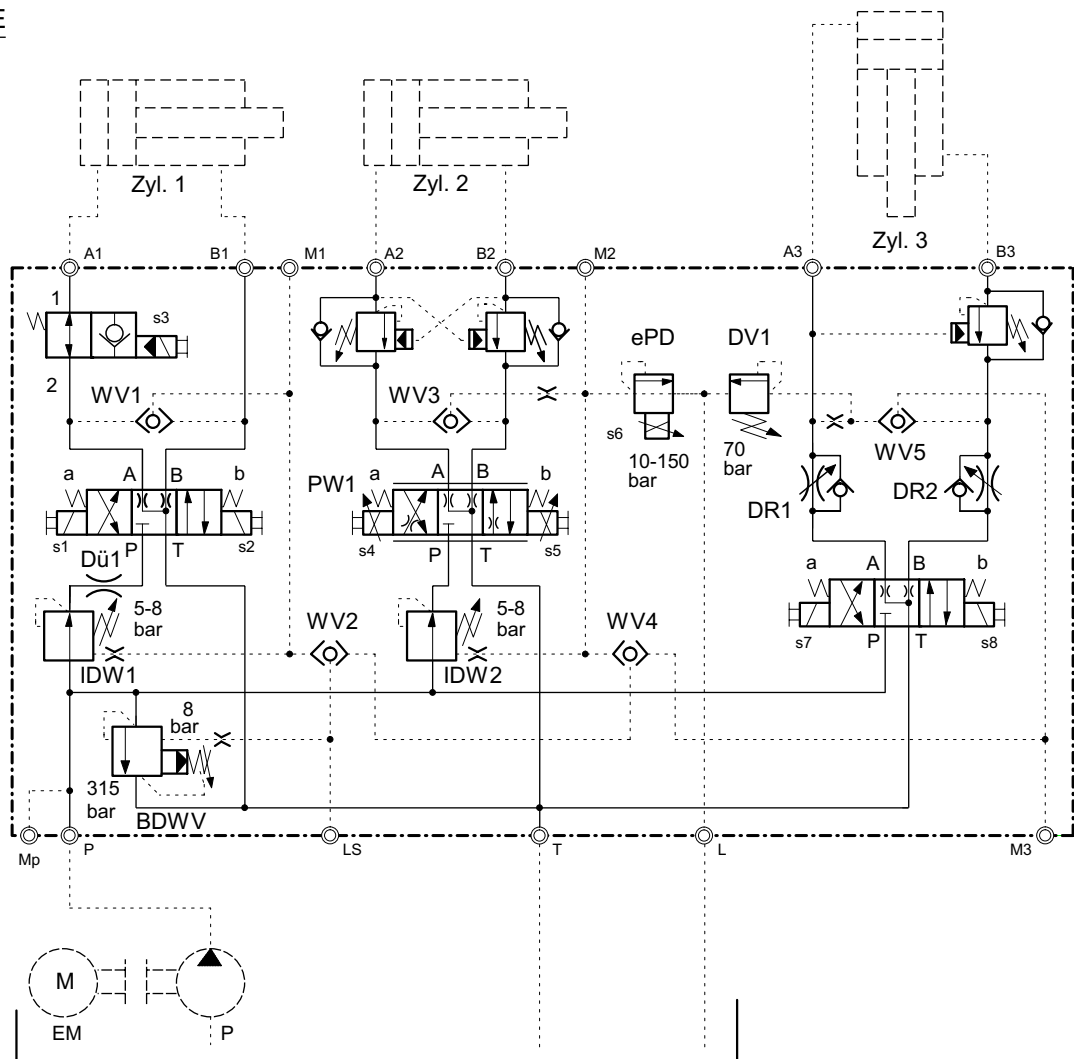

The speed of Zyl. 2 is determined by the 4/3 proportional directional valve, the maximum pressure by a pilot valve, in this case a proportional relief valve (ePD).

The interaction of the inline hydrostat and the proportional pressure relief pilot valve produces a 2-way proportional pressure reducing function.

Cylinder Zyl. 3 must operate alone and at a constant, load-

independent speed. The lifting speed is determined by the throttle valve DR2, the maximum pressure by the pilot stage of the bypass hydrostat valve.

The lowering speed is determined by the throttle valve DR1.

When lowering (extending), the cylinder must be protected against buckling of the piston rod; the pressure is limited to 70 bar by a pilot relief valve DV1 in the load sensing line.