



Master Module

Series EBM...

PO Box 38
Strathfieldsaye, VIC, 3551
1800 OIL SOL
1800 645 765

sales@oilsolutions.com.au

www.oilsolutions.com.au

"For All Your Hydraulic Needs"



Contents

Page

1	Overview EBM Modules	5
2	EBM-107000 Multifunction card	6
2.1	Description	6
2.2	Application example	6
2.3	Technical data	6
2.4	Dimension	7
2.5	Connector pinout	7
2.6	Commissioning	8
2.7	Setup procedure	8
2.8	Diagnostic	11
2.9	Ordering information	12
2.10	Fault Finding	13
3	EBM-107001 Multifunction Card	14
3.1	Description	14
3.2	Application examples	14
3.3	Technical Data	14
3.4	Dimension	15
3.5	Connector pinout	15
3.6	Commissioning	16
3.7	Setup procedure	16
3.8	Diagnostic	20
3.9	Ordering informations	20
3.10	Fault finding	21
4	EBM-200... Slave module	22
4.1	Description	22
4.2	Application examples	22
4.3	Technical Data	22
4.4	Input Characteristics	24
4.5	Output Characteristics	27
4.6	Dimension	31
4.7	Connector pinout	32
4.8	Diagnostic	33
4.9	Ordering Informations	33
5	EBM-800 Master module	34
5.1	Description	34
5.2	Application examples	34
5.3	Technical Data	34

5.4	Input Characteristics	35
5.5	Output Characteristics	36
5.6	Dimension	37
5.7	Connector pinout	37
5.8	Ordering information	38

1 Overview EBM Modules

<p>EBM-107000 Multifunction card</p> 	<p>Description</p> <p>Inputs: 1 analog Outputs: 2 proportional</p> <p>See chapter 2</p>
<p>EBM-107001 Multifunction card</p> 	<p>Description</p> <p>Inputs: 2 analog 1 digital Outputs: 4 proportional 4 On/Off outputs</p> <p>See chapter 3</p>
<p>EBM-200000 slave module</p> 	<p>Description</p> <p>Inputs: 8 analog 4 digital Outputs: 4 digital 3 A 6 PWM 7 A 4 PWM 3 A</p> <p>See chapter 4</p>
<p>EBM-210000 slave module</p> 	<p>Description</p> <p>Inputs: 6 analog 8 digital 1 PT1000 Outputs: 4 PWM 3 A 4 H-bridge 5 A 4 H-bridge 12 A</p> <p>See chapter 4</p>
<p>EBM-220000 slave module</p> 	<p>Description</p> <p>Inputs: 8 analog 6 digital 8 PT1000 Outputs: 4 digital 3 A 6 PWM 7 A 4 PWM 3 A</p> <p>See chapter 4</p>
<p>EBM-800 Master Module</p> 	<p>Description</p> <p>Used as an expansion element in CAN bus system</p> <p>Inputs: 8 analog 8 digital Outputs: 4 PWMi (standard, expandable with MX module) 4 H-bridges</p> <p>See chapter 5</p>

2 EBM-107000 Multifunction card



- Wear-free semiconductor output stages
- 2 prop. power outputs with current measurement
- Flexible configuration thanks to 1 analogue input
- User-friendly setup via CAN bus
- Supply voltage range from 12 V to 30 V DC
- Integral reference-voltage source for direct supply of setpoint sources
- Robust, encapsulated design, specifically for mobile machines

2.1 Description

The EBM-107000 plug-in card is a digital multifunction electronic unit. It has 8 power outputs (2 x prop. with current measurement), one analogue input (voltage or current, switchable). With the configurable analogue inputs, it can be flexibly configured to suit a large number of setpoint sources. These can be parametrised for voltage or current measurement. The outputs are switched by contactless, and therefore wear-free, semiconductor output stages.

The card can be used to control proportional directional valves as well as ON/OFF valves (e.g. seat valves). The card itself is controlled by an analogue joystick with one or two axes, or by potentiometers. The electronic unit is also equipped with an enable input. If the joystick is deflected, the directional valve is energised proportionally to the amount of deflection.

2.2 Application example

- Processing signals from joysticks for controlling proportional and ON/OFF directional valves in mobile hydraulic systems.
- Agricultural machinery
- Municipal equipment technology
- Forestry machines
- Construction equipment

2.3 Technical data

General Characteristics	Unit	Description, value
Supply voltage	V DC	12/24 V nominal voltage \pm 15%, ripple < 10%
Current consumption of the electronics (without solenoid) and CAN-bus	mA	ca. 20
Reference voltage	V DC	8 (provided on the card), max. load 50 mA
Inputs: 1 analog input		Voltage or current, switchable
Input impedance: voltage input current input	k Ω	approx. 76 0.2
Outputs: 2 proportional outputs		4 PWM channels with current measurement for controlling two directional valve sections, max. 3 A
Diagnostic		3 LEDs
PWM frequency	Hz	100
Protection class		IP 67
Operating temperature	$^{\circ}$ C	-40...+85
Dimensions	mm	140 x 100 x 45
Weight	g	ca. 200
Connection		JAE MX23A26NF1 plug-in connector, 26-pin

2.4 Dimension

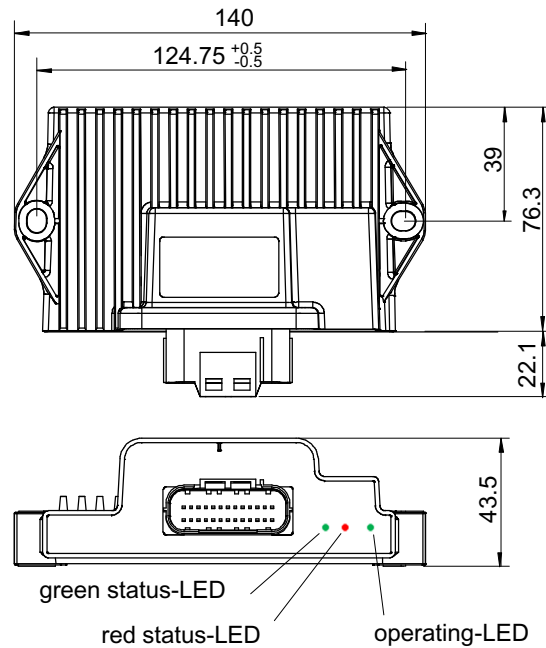

2.5 Connector pinout

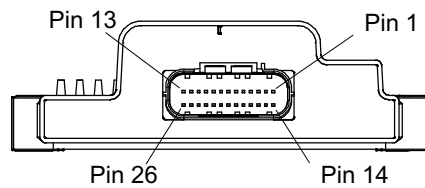

Pin	Pin Description	Pin	Pin Description
1	Enable pin	14	Reference voltage +8 V
2	n. c.	15	n. c.
3	n. c.	16	Analogue in 1
4	n. c.	17	CAN low
5	n. c.	18	CAN high
6	Ground (logic)	19	Ground (supply)
7	Supply voltage	20	Ground (supply)
8	Supply voltage	21	Ground (solenoid)
9	Supply voltage	22	Ground (supply)
10	Supply voltage	23	Ground (solenoid)
11	Solenoid CH1 positive	24	Ground (solenoid)
12	Solenoid CH2 positive	25	Ground (solenoid)
13	n. c.	26	n. c.

2.5.1 Connection example

Please provide a 10 A fuse for connection to the vehicle voltage system.

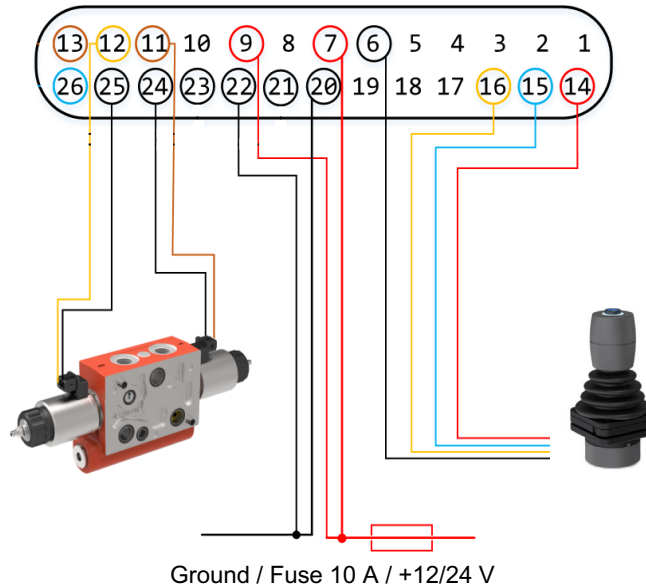

2.6 Commissioning

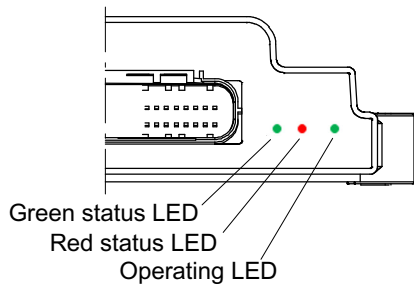

Connect the electronics in accordance with the connection pinout.

If the green operating LED does not light up, check the power supply.

2.7 Setup procedure

The electronics are configured via the CAN bus. This is accessible via pins 17 and 18 of the connector. A terminating resistor with a 120 Ω rating is required in the CAN bus cable. The CAN bus is not used during normal operation. The parametrisation is carried out with the PC program "PmTool".

Baud rate: 250 kBits/s, device address: 9

There are three blocks of parameters:

- Application-specific parameters
- Input parameters, for all parameters that relate to the inputs
- Output parameters, for all parameters that relate to the outputs

2.7.1 Application parameters

Parameter	Value	Unit	Range
Status1	0xE		0x0 ... 0xFFFF
Status2	0x0		0x0 ... 0xFFFF
Status3	0x0		0x0 ... 0xFFFF
R Solenoid	3.5	[Ohm]	2.0 ... 80.0

2.7.2 Setting the application parameters

Status 1 to 3 can be used to activate various functions of the application:

Status 1: +1 = Joystick parameters defined by customer (otherwise, factory-set parameters)

Status 3: free

R Solenoid: Coil resistance of the solenoid coil used. Matching of the PWM outputs CH5 ... CH8.

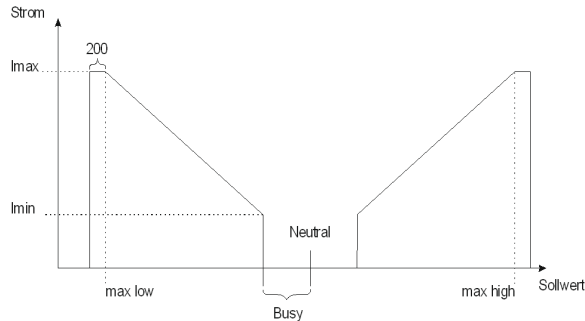

2.7.3 Input parameters

Output CH1	Output CH2	Output CH3	Output CH4	Output CH5	Output CH6	Output CH7	Output CH8	Input Parameter	Application Parameter	Test	Device Information	Save and restore
								<input checked="" type="checkbox"/> all				
Joystick type								0	<input checked="" type="checkbox"/>		0 ... 3	
Joystick Busy threshold								200	<input checked="" type="checkbox"/>	[mV/μA]	1 ... 3000	
Joystick Neutral								2500	<input checked="" type="checkbox"/>	[mV/μA]	2000 ... 14000	
Joystick max low								500	<input checked="" type="checkbox"/>	[mV/μA]	500 ... 5000	
Joystick max high								4500	<input checked="" type="checkbox"/>	[mV/μA]	4000 ... 20000	

2.7.3.1 Parameters for the input signals

In order to be able to use as many different setpoint sources as possible, there are various parametrisation options.

Joystick type: Four predefined joysticks are available for selection:

Value	Setpoint voltage from source
0	2,5 V ± 2 V
1	4,0 V ± 3,15 V
2	4,0 V ± 3,5 V
3	12 mA ± 8 mA

Table with pre-set profiles for "common" input signals via the "Joystick type" parameter.

Joystick Busy Threshold: Threshold in mV above which a joystick deflection is detected

Joystick Neutral: Neutral position in mV

Joystick max low: Minimum value in mV at maximum deflection
Example: Joystick Neutral: 4 V, maximal lowering: 2 V
Joystick max low: 2000

Joystick max high: Maximum value in mV at maximum deflection
Example: Joystick Neutral: 4 V, maximal lifting: 6 V
Joystick max high: 6000

2.7.4 Output parameters

Output CH1	Output CH2	Output CH3	Output CH4	Output CH5	Output CH6	Output CH7	Output CH8	Input Parameter	Application Parameter	Test	Device Information	Save and restore
<input checked="" type="checkbox"/> all												
Fine control characteristic	1	<input checked="" type="checkbox"/>										0 ... 9
Min current	700	<input checked="" type="checkbox"/>	[mA]									50 ... 1200
Max current	1600	<input checked="" type="checkbox"/>	[mA]									300 ... 3000
Strategy	3	<input checked="" type="checkbox"/>										0 ... 4
Ramp start	0	<input checked="" type="checkbox"/>	[ms]									0 ... 2000
Ramp stop	0	<input checked="" type="checkbox"/>	[ms]									0 ... 2000
Set point min	10	<input checked="" type="checkbox"/>										0 ... 10000
Set point max	1000	<input checked="" type="checkbox"/>										0 ... 30000
Power reduction time	2	<input checked="" type="checkbox"/>	[s]									0 ... 5
Power reduction SP	60	<input checked="" type="checkbox"/>	[%]									0 ... 100
SW On threshold	10	<input checked="" type="checkbox"/>	[%]									0 ... 100
KP CH1	35	<input checked="" type="checkbox"/>										0 ... 255
KI CH1	10	<input checked="" type="checkbox"/>										0 ... 255

2.7.4.1 Parameters for output signals

In order to be able to use as many different valves as possible, the following parametrisation options are available for the output channels:

To ensure optimum resolution, the currents need to be set for each proportional valve.

No settings are needed for ON/OFF valves. The current range is defined by the minimum current (I_{min}) and the maximum current (I_{max}).

Fine control characteristic: Fine control of 50%

- Fine control characteristic: 0: OFF (no flow)
 1: Linear from 0...max
 2 - 9: 20...90% of joystick deflection with 50% flow rate.
 From n%...100% joystick deflection, 100% flow rate

Minimum current: Current at a setpoint signal of 1 %.
Maximum current: Current at a setpoint signal of 100%.
Strategy: 1: ON/OFF
 2: PWM
 3: PWMi
 4: ON/OFF with power reduction

Ramp start: Time in ms until the maximum current I_{max} is reached, with a setpoint jump of 0%..100%.

Ramp stop: Time in ms until the output switches off, with a setpoint jump of 100%..0%.

Power reduction time: The ON/OFF output is switched on for a period of 0 s ... 5 s. The current is then reduced.

Power reduction setpoint (SP): Current value 0..100% for the ON/OFF output after the "Power reduction time"

ON/OFF 'On' threshold: Setpoint threshold 0%..100% for ON/OFF 'On'

2.7.4.2 Ramp function

A ramp function can be set using the parameters "Ramp start" and "Ramp stop". The value specifies the time in milliseconds after which the current reaches the set I_{max} with a setpoint jump of 100%.

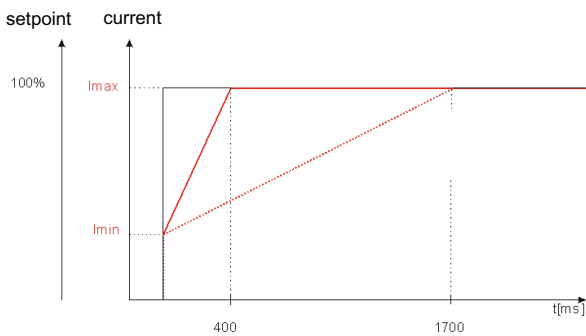

2.7.4.3 Fine control

If fine control of the joystick functions is required, the "Fine control" parameter can be set in the range 2-9 (20%-90%).

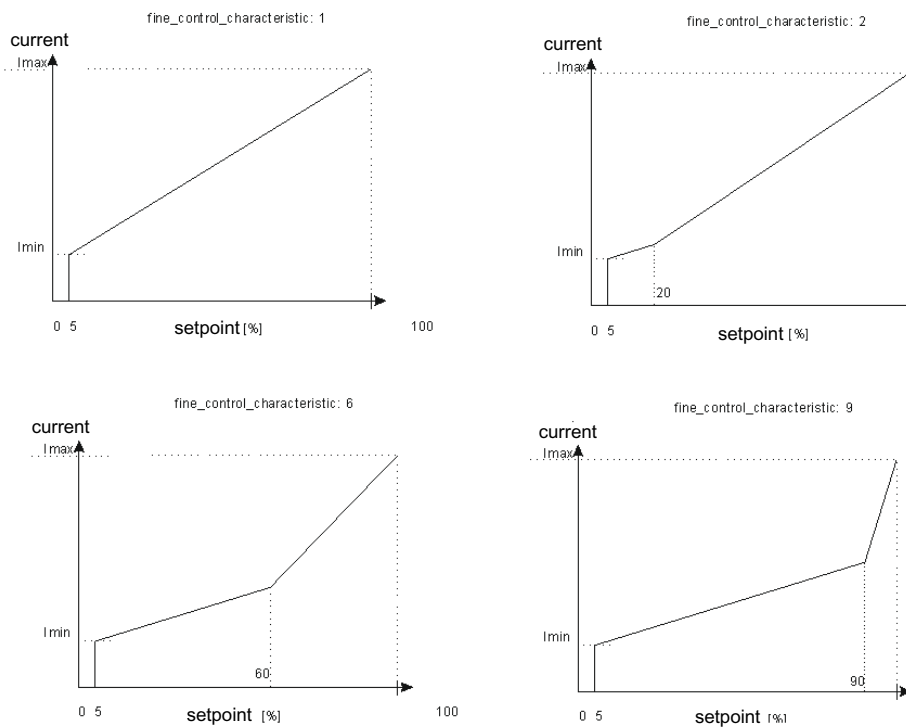

2.8 Diagnostic

Status LED green	ON	OFF
Operating mode OK	0,5 s	0,5 s
Analogue input joystick not OK	On	-
Enable not connected or $U_b < 10 V$	0,1 s	0,1 s

Status-LED red	ON	OFF
Current cannot be reached, Controller max	3 s	0,5 s
Current cannot be reached, Controller min	1 s	2 s

Operating LED: Power supply is available

2.9 Ordering information

2.9.1 Ordering information for multifunction card

Type	Model code	Part number
Multifunction card	EBM-107000	100041121

2.9.2 Accessories

Type	Ordering code	Note
EKAB-10700*	100041120	Cable harness

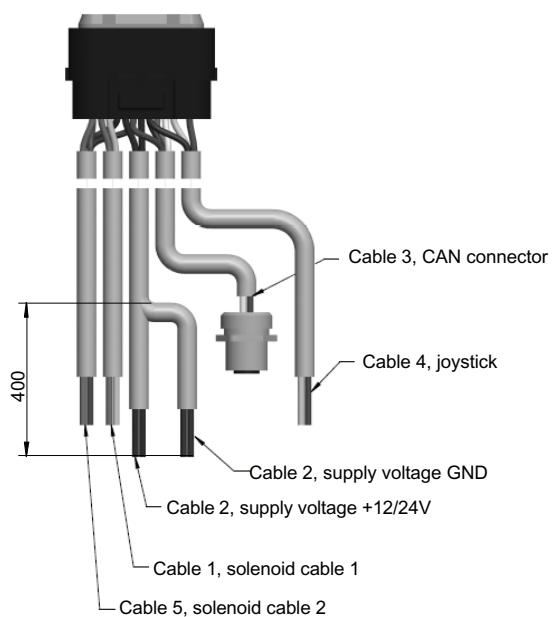

Cable	Length
Solenoid cable 1	440 mm
Supply cable	900 mm
CAN connector	200 mm
Joystick cable	2100 mm
Solenoid cable 2	440 mm

2.10 Fault Finding

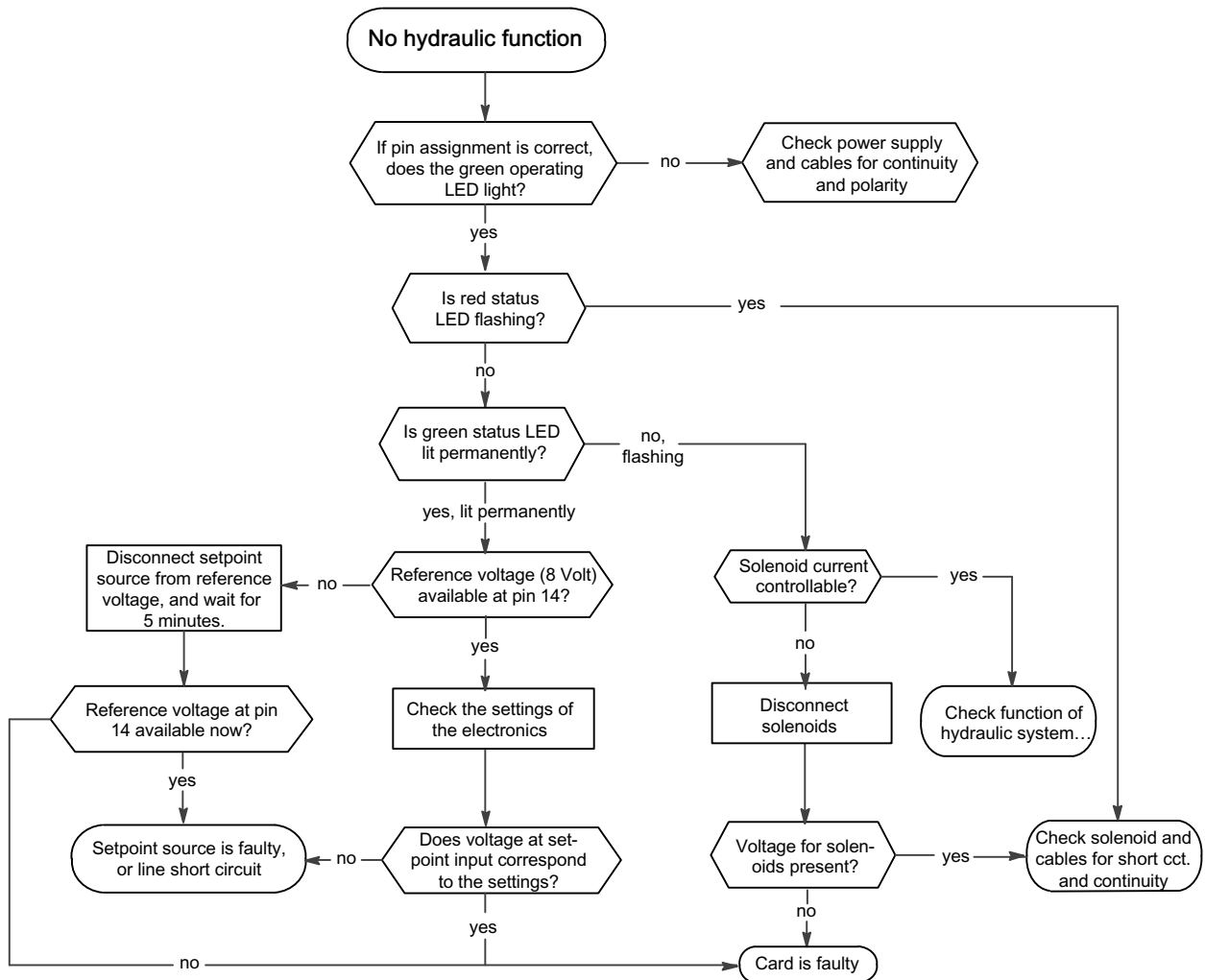

3 EBM-107001 Multifunction Card



- Wear-free semiconductor output stages
- 4 prop. power outputs with current measurement
- Flexible configuration thanks to 2 analogue inputs
- Pre-configured profiles can be selected for standard applications
- User-friendly setup via CAN bus
- Supply voltage range from 12 V to 30 V DC
- Integral reference-voltage source for direct supply of setpoint sources
- Robust encapsulated design, specifically for mobile machines

3.1 Description

The EBM-107001 plug-in card is a digital multifunction electronic unit. It has 8 power outputs (4 x prop. with current measurement, 4 x ON/OFF), two analogue inputs (voltage or current, switchable) and one digital (ON/OFF) input. With 2 configurable analogue inputs, it can be flexibly configured to suit a large number of setpoint sources. These can be parametrised for voltage or current measurement. The outputs are switched by contactless, and therefore wear-free, semiconductor output stages.

The card can be used to control proportional directional valves as well as ON/OFF valves (e.g. seat valves). The card itself is controlled by an analogue joystick with one or two axes, or by potentiometers. The electronic unit is also equipped with an enable input. If the joystick is deflected, the directional valve is energised proportionally to the amount of deflection. ON/OFF outputs can also be activated at the same time, depending on the parametrisation in the setup.

3.2 Application examples

- Processing signals from joysticks for controlling proportional and on/off directional valves in mobile hydraulic systems.
- Agricultural machinery
- Municipal equipment technology
- Forestry machines
- Construction equipment

3.3 Technical Data

General Characteristics	Unit	Description, value
Supply voltage	V DC	12 / 24 V nominal voltage \pm 15%, ripple < 10%
Current consumption of the electronics (without solenoid) and CAN-bus	mA	ca. 20
Reference voltage	V DC	8 (provided on the card), max. load 50 mA
Inputs: 2 Analogue inputs 1 Digital input		Voltage or current, switchable NPN or PNP logic, switchable
Input impedance: Voltage input Current input	k Ω	approx. 76 0,2
Outputs: 4 Proportional outputs 4 ON/OFF outputs		4 PWM channels with current measurement for controlling two directional valve sections, max. 3 A For auxiliary functions
Diagnostic		3 LEDs
PWM frequency	Hz	100
Protection class		IP 67

General Characteristics	Unit	Description, value
Operating temperature	° C	-40...+85
Dimensions	mm	140 x 100 x 45
Weight	g	ca. 200
Connection		JAE MX23A26NF1 Plug-in connector, 26-pin

3.4 Dimension

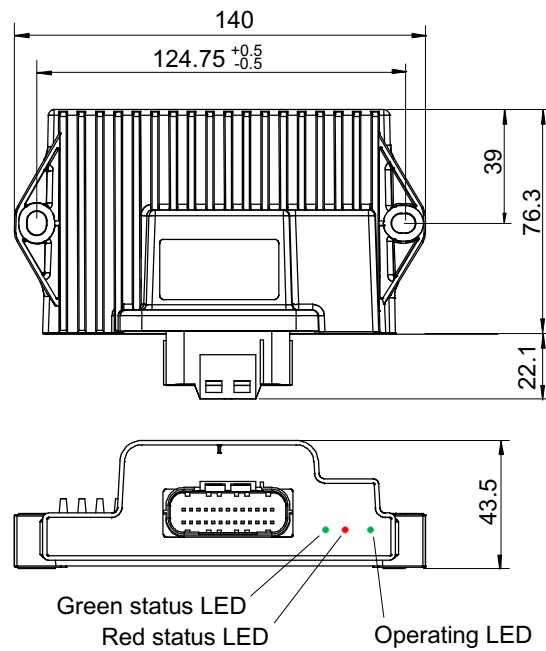

3.5 Connector pinout

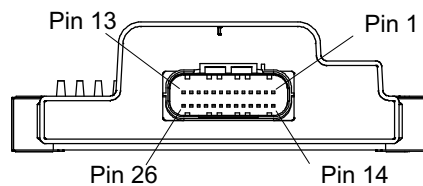

Pin	Pin Description	Pin	Pin Description	Pin	Pin Description
1	Enable pin	11	Solenoid CH1 positive	21	Ground (solenoid)
2	ON/OFF function CH5	12	Solenoid CH2 positive	22	Ground (supply)
3	ON/OFF function CH6	13	Solenoid CH3 positive	23	Ground (solenoid)
4	ON/OFF function CH7	14	Reference voltage +8 V	24	Ground (solenoid)
5	ON/OFF function CH8	15	Analog in 2	25	Ground (solenoid)
6	Ground (logic)	16	Analog in 1	26	Solenoid CH4 positive
7	Supply voltage	17	CAN low		
8	Supply voltage	18	CAN high		
9	Supply voltage	19	Ground (supply)		
10	Supply voltage	20	Ground (supply)		

3.5.1 Connection example

Please provide a 10 amp fuse for connection to the vehicle voltage system.

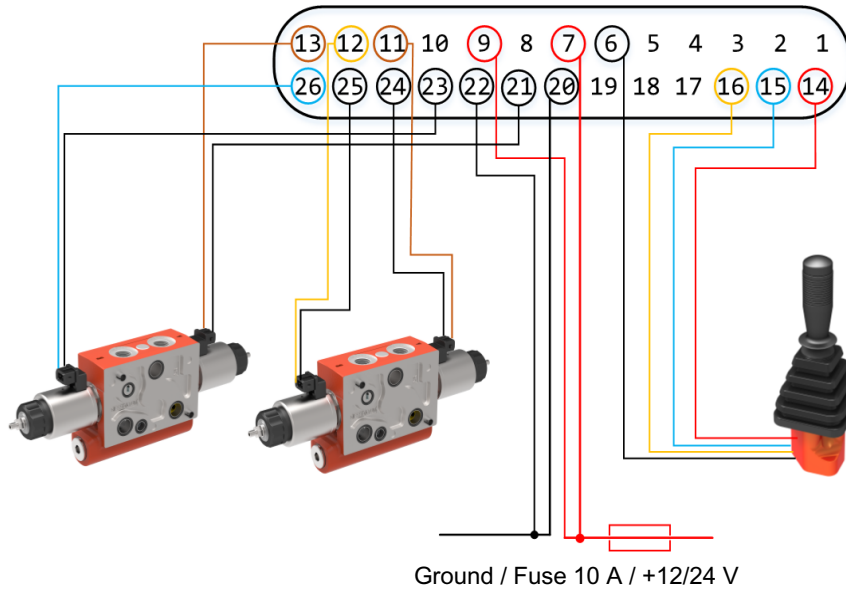

3.6 Commissioning

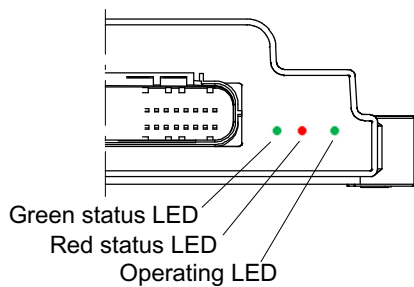

Connect the electronics in accordance with the connection pinout.

If the green operating LED does not light up, check the power supply.

3.7 Setup procedure

The electronics are configured via the CAN bus. This is accessible via pins 17 and 18 of the connector. A terminating resistor with a 120 Ohm rating is required in the CAN bus cable. The CAN bus is not used during normal operation. The parametrisation is carried out with the PC program "PrmTool".

Baud rate: 250 kBits/s, device address: 9

3.7.1 Application parameters

There are three blocks of parameters:

- Application-specific parameters
- Input parameters, for all parameters that relate to the inputs
- Output parameters, for all parameters that relate to the outputs

Parameter	Value	Unit	Range
Status1	0xE		0x0 ... 0xFFFF
Status2	0x0		0x0 ... 0xFFFF
Status3	0x0		0x0 ... 0xFFFF
R Solenoid	3.5	[Ohm]	2.0 ... 80.0

3.7.1.1 Setting the application parameters

Status 1 to 3 can be used to activate various functions of the application:

- Status 1:** +1 = Joystick parameters defined by customer (otherwise, factory-set parameters)
 +2 = Joystick with 2 axes
 +4 = CH5, CH6 with deflection of the Y-axis
 +8 = CH7, CH8 with deflection of the X-axis
- Status 2:** +1 = Enable input is not active
- Status 3:** Free
- R Solenoid:** Coil resistance of the solenoid coil used. Matching of the PWM outputs CH5 ... CH8.

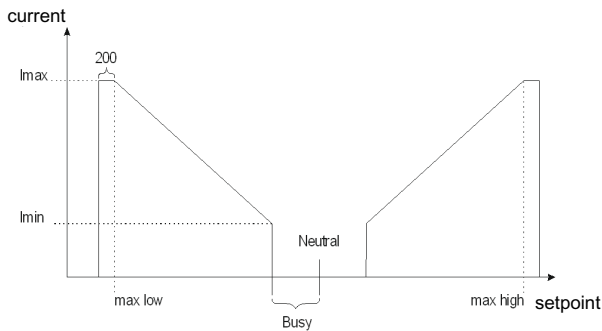

A user-defined range can be used. To do this, status1 must be set to +1. The parameters "Joystick Busy", "Joystick Neutral", "Joystick max low" and "Joystick max high" can then be defined by the user.

If an out-of-range condition is detected, all outputs are switched off. An out-of-range occurs when the analogue value at the input exceeds 200 mV or 200 uA of "Joystick max low" or "Joystick max high".

3.7.2 Input parameters

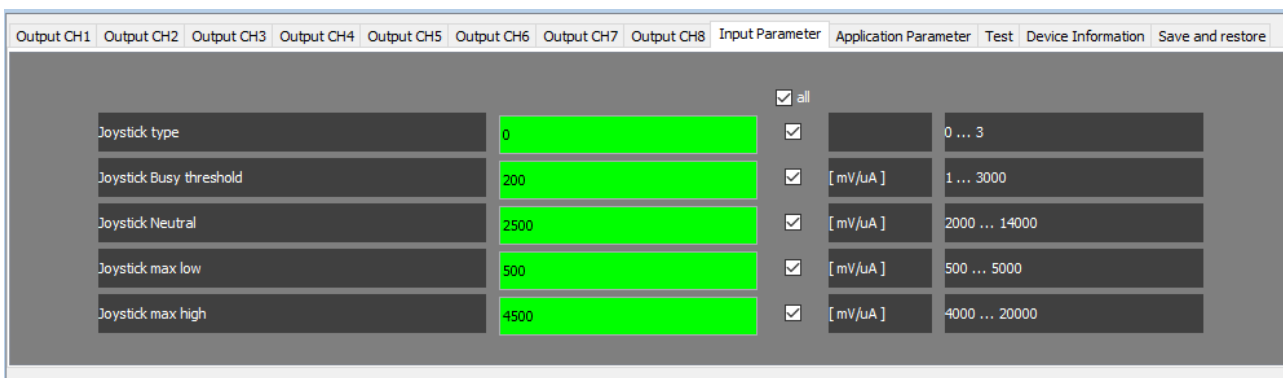

3.7.3 Parameters for the input signals

In order to be able to use as many different setpoint sources as possible, there are various parametrisation options.

Joystick type: Four predefined joysticks are available for selection:

Value	Setpoint voltage from source
0	2,5 V ± 2 V
1	4,0 V ± 3,15 V
2	4,0 V ± 3,5 V
3	12 mA ± 8 mA

Table with pre-set profiles for "common" input signals via the "Joystick type" parameter.

Joystick Busy Threshold: Threshold in mV above which a joystick deflection is detected

Joystick Neutral: Neutral position in mV

Joystick max low: Minimum value in mV at maximum deflection
 Example: Joystick Neutral: 4 V, maximum lowering: 2 V
 Joystick max low: 2000

Joystick max high: Maximum value in mV at maximum deflection
 Example: Joystick Neutral: 4 V, maximal lifting: 6 V
 Joystick max high: 6000

3.7.4 Output parameters

Output CH1	Output CH2	Output CH3	Output CH4	Output CH5	Output CH6	Output CH7	Output CH8	Input Parameter	Application Parameter	Test	Device Information	Save and restore
<input checked="" type="checkbox"/> all												
Fine control characteristic	1	<input checked="" type="checkbox"/>									0 ... 9	
Min current	700	<input checked="" type="checkbox"/>						[mA]			50 ... 1200	
Max current	1600	<input checked="" type="checkbox"/>						[mA]			300 ... 3000	
Strategy	3	<input checked="" type="checkbox"/>									0 ... 4	
Ramp start	0	<input checked="" type="checkbox"/>						[ms]			0 ... 2000	
Ramp stop	0	<input checked="" type="checkbox"/>						[ms]			0 ... 2000	
Set point min	10	<input checked="" type="checkbox"/>									0 ... 10000	
Set point max	1000	<input checked="" type="checkbox"/>									0 ... 30000	
Power reduction time	2	<input checked="" type="checkbox"/>						[s]			0 ... 5	
Power reduction SP	60	<input checked="" type="checkbox"/>						[%]			0 ... 100	
SW On threshold	10	<input checked="" type="checkbox"/>						[%]			0 ... 100	
KP CH1	35	<input checked="" type="checkbox"/>									0 ... 255	
KI CH1	10	<input checked="" type="checkbox"/>									0 ... 255	

3.7.4.1 Parameters for output signals

In order to be able to use as many different valves as possible, the following parametrisation options are available for the output channels:

To ensure optimum resolution, the currents need to be set for each proportional valve. No settings are needed for On/Off valves. The current range is defined by the minimum current (I_{min}) and the maximum current (I_{max}).

Fine control characteristic: Fine control of 50% flow rate

Fine control characteristic: 0: OFF (no flow)
 1: Linear from 0...max
 2 - 9: 20...90% of joystick deflection with 50% flow rate.
 From n% ...100% joystick deflection, 100% flow rate

Minimum current: Current at a setpoint signal of 1%.

Maximum current: Current at a setpoint signal of 100%.

Strategy: 1: ON/OFF
 2: PWM
 3: PWMi
 4: ON/OFF with power reduction

Ramp start: Time in ms until the maximum current I_{max} is reached, with a setpoint jump of 0%..100%.

Ramp stop: Time in ms until the output switches off, with a setpoint jump of 100%..0%.

Power reduction time: The ON/OFF output is switched on for a period of 0 s ... 5 s. The current is then reduced.

Power reduction setpoint (SP): Current value 0..100% for the ON/OFF output after the "Power reduction time"

ON/OFF 'On' threshold: Setpoint threshold 0%..100% for ON/OFF 'On'

Ramp function

A ramp function can be set using the parameters "Ramp start" and "Ramp stop". The value specifies the time in milliseconds after which the current reaches the set I_{max} with a setpoint jump of 100%.

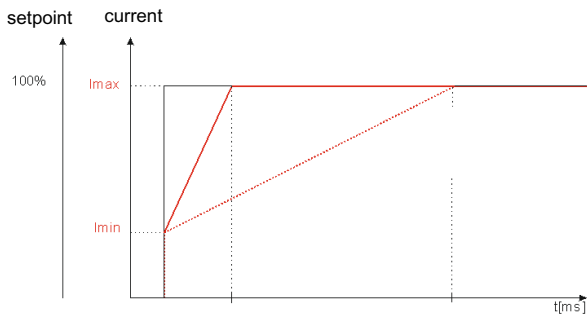

Fine control

If fine control of the joystick functions is required, the "Fine control" parameter can be set in the range 2-9 (20%-90%).

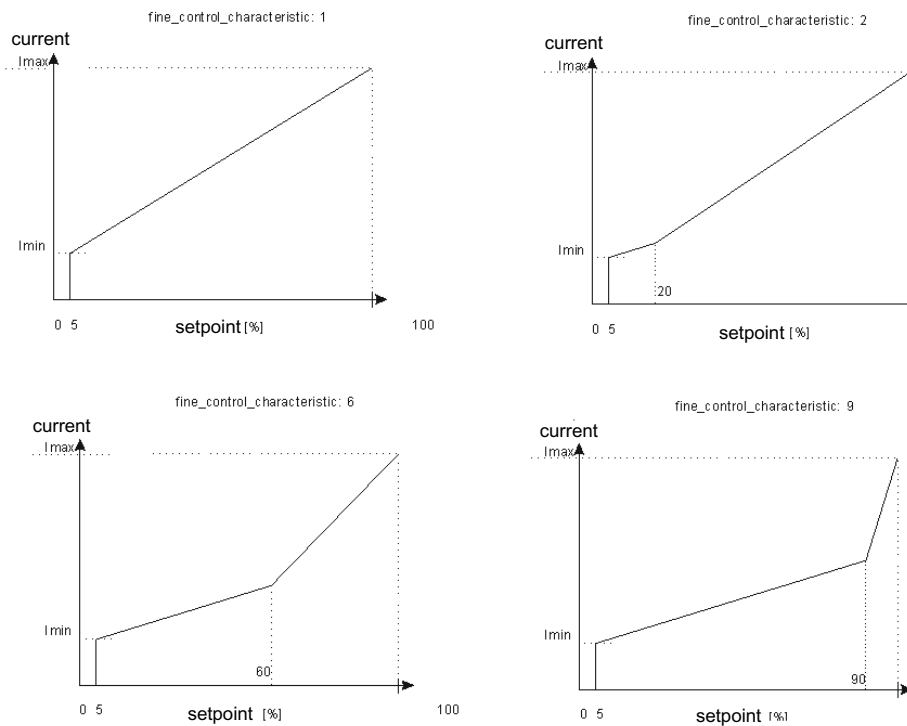

Power reduction for ON/OFF outputs

It is possible to set a power reduction function for the ON/OFF outputs. This means that the ON/OFF output delivers maximum current when it is switched on. The

coil current is then reduced after an adjustable period of 0...5 s. This saves energy and the coil does not heat up as much.

The following parameters must be set for reduced-power operation:

Power reduction time: Time 'on' until power is reduced

Power reduction setpoint (SP): Current value 0...100% with active power reduction

Example: The power reduction should start 1 s after power-on, and the current should then be reduced by 20%.

Power reduction time: 1
Power reduction SP: 80

3.8 Diagnostic

Status-LED green	ON	OFF
Operating mode OK	0,5 s	0,5 s
Analogue input joystick not OK	ON	-
Enable not connected or $U_b < 10\text{ V}$	0,1 s	0,1 s

Status-LED red	ON	OFF
Open Load CH5 - CH8	0,5 s	0,5 s
Current cannot be reached, Controller max	3 s	0,5 s
Current cannot be reached, Controller min	1 s	2 s

Operating-LED: Power supply is available

3.9 Ordering informations

3.9.1 Ordering informations for multifunction card

Type	Model code	Part number
Multifunction card	EBM-107001	100041524

3.9.2 Accessories

Type	Ordering code	Note
EKAB-10700*	100041120	Cable harness

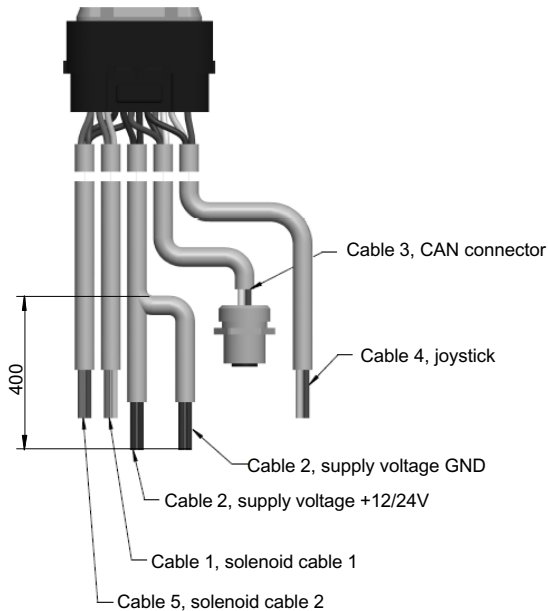

Cable	Length
Solenoid cable 1	440 mm
Supply cable	900 mm
CAN connector	200 mm
Joystick cable	2100 mm
Solenoid cable 2	440 mm

3.10 Fault finding

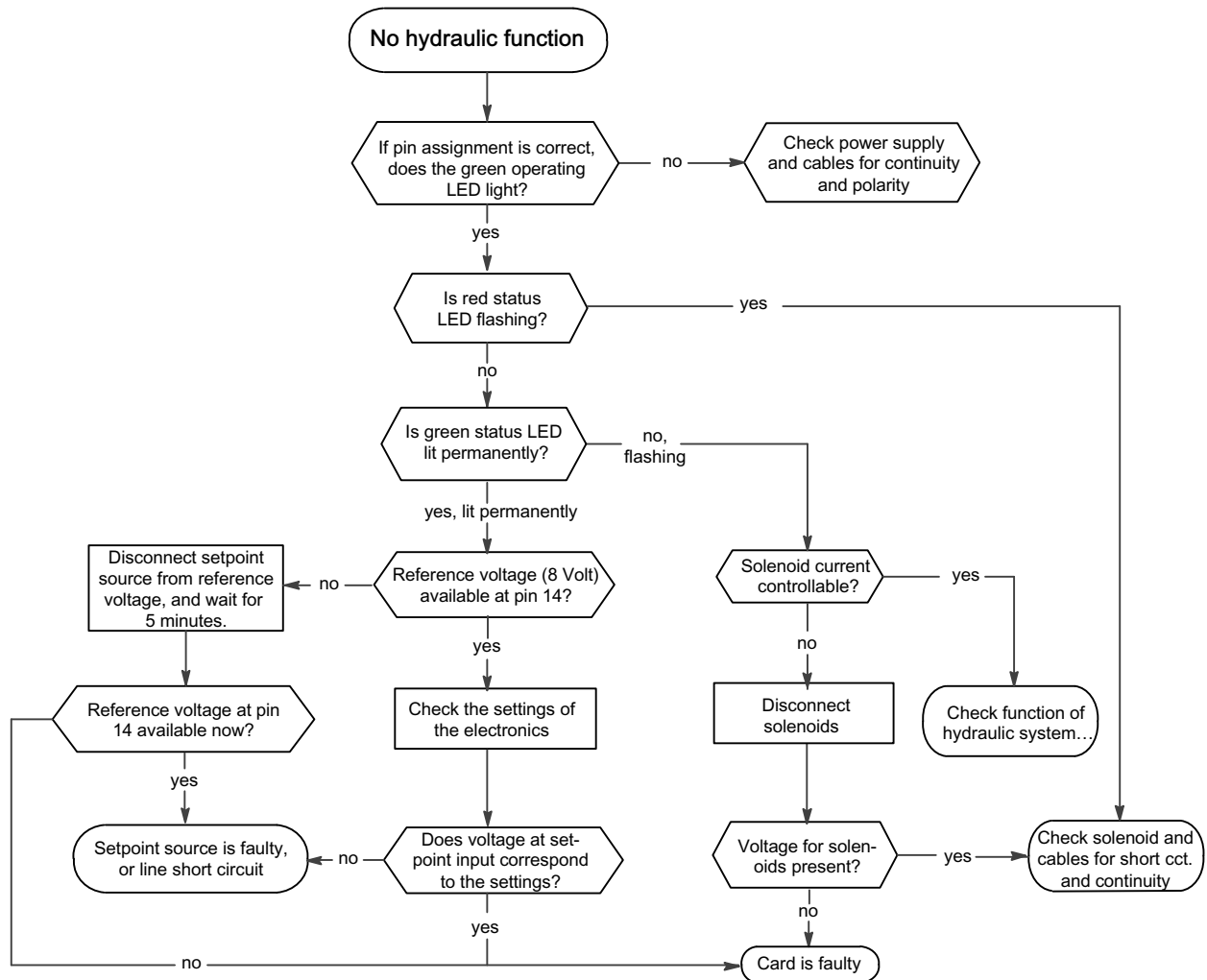

4 EBM-200... Slave module



- Molex TM CMC plug 48-pole
- Compact encapsulated enclosure
- 2 LED for diagnostic and CAN status
- Various component configurations (AE, CAN)
- Certificates: ECE R10 (E1), CE ISO 14982

4.1 Description

The EBM-200 expansion module is a cost-effective and universally applicable IO extension for mobile machinery. It can take on almost any remote task and this way significantly reduce wiring expenses. With this module a number of usual market sensors and actuators can be operated. With technologies such as dithering and flow control, hydraulic valves can be activated optimally.

The communication interface CANopen allows the integration into conventional CAN networks used in mobile machinery. Thanks to its rugged and encapsulated enclosure it is applicable in any situation even under harsh environmental conditions.

4.2 Application examples

- Agricultural machinery
- Municipal equipment technology
- Forestry machines
- Construction equipment
- Road-construction machinery
- Transport and materials handling

4.3 Technical Data

4.3.1 Overview of inputs and outputs

Inputs / Outputs	EBM-200000	EBM-210000	EBM-220000
Total number of inputs	12	15	16
Input digital / frequency	4	8	6
Input 12 bit analog current or voltage	8	6	8
Input 16 bit analog current or voltage	-	-	2
Input PT1000	-	1	8
Short-circuit-proof sensors	3	3	8
Total number of outputs	14	12	3
PWM output 3A with precision current measurement	4	4	-
PWM output 7A	6	-	-
PWM output 3A	4	-	-
Output half-bridge 5A, combinable to full-bridge	-	4	-
Output half-bridge 12A, combinable to full-bridge	-	4	-
Output analog 0...10 V	-	-	3

4.3.2 General Technical Data

General Characteristics	Unit	Description, value
Enclosure		Polyamide
CAN port		1 CANOpen
Input impedance: voltage input	kΩ	35
Diagnostic		3 LEDs
PWM frequency	Hz	100
Protection class		IP 65
Operating temperature	° C	-40...+85
Dimensions	mm	140 x 94 x 43
Weight	g	ca. 325

4.3.3 Electrical characteristics

Power supply of output drivers	Unit	Description, value
Current	A	max. 25
Supply voltage	V DC	8...32
Protection against polarity reversal	A	25
Voltage protection	V	36 V for 1 hour at T _{max} -20°C, function state C
ECU	Unit	Description, value
Supply voltage	V DC	8...32
Protection against polarity reversal	A	2
Current consumption	mA	12V approx. 49 mA + total current at VEXT_SEN 24V approx. 34 mA + total current at VEXT_SEN

4.4 Input Characteristics

4.4.1 Inputs EBM-200000

4.4.1.1 Digital/analog inputs (DI_PNP, AI) can be configured as:

Characteristics	Description, value, unit	
Analog inputs	Abbreviation	AI
	Quantity	8
Voltage inputs	Voltage input	0...10V
	Resolution	12 bit _s
	Input resistance	≥35 kΩ
	Load resistor	120 Ω
	Measuring accuracy	± 2% relative to the rated measuring range
Moving average filter	Filter depth range	1...32
	At 1 no filtering is active.	
Current inputs	Measuring range	0...20 mA
	Overcurrent range	21...24 mA
	Measuring accuracy	± 1,5% relative to the current measurement range 20 mA
	In case of overcurrent, the current measurement is interrupted. At the end of the overcurrent event, the current measurement is automatically resumed.	
As DI_PNP	Switch-on level	≥ 4,6 V
	Switch-off level	≤ 1,6 V
	Input resistance	≥ 35 kΩ
	Input frequency	max. 10 Hz

4.4.1.2 Digital inputs (DI_P) can be configured as:

Characteristics	Description, value, unit	
Digital inputs with frequency measurement	Abbreviation	DI_P
	Quantity	4
	Pulldown resistor	< 5,6 kΩ
	Switch-on level	≥ 4,6 V
	Switch-off level	≤ 1,6 V
	Input frequency	0,1Hz...10 kHz
	Dielectric strength	max. 32 V

4.4.1.3 Configuration inputs (CFG1_IN, CFG2_OUT) can be configured as:

Characteristics	Description, value, unit	
Configuration inputs for configuring the node ID	Abbreviation	CFG1_IN, CFG2_OUT
	Quantity	2

4.4.2 Inputs EBM-210000

4.4.2.1 Analog inputs (AI) can be configured as:

Characteristics	Description, value, unit
Analog inputs	Abbreviation AI Quantity 6 Resolution 12 bit
Voltage measurement	Rated measuring range 0...10V Overvoltage measurement 10...12 V Input resistance $\geq 35 \text{ k}\Omega$ Load resistor 120 Ω Maximum voltage 32 V Measuring accuracy $\pm 2\%$ relative to the rated measuring range 10 V
Current measurement	Measuring range 0...20 mA Overcurrent range 21...24 mA Measuring accuracy $\pm 1,5\%$ relative to the current measurement range 20 mA In case of overcurrent, the current measurement is interrupted. At the end of the overcurrent event, the current measurement is automatically resumed.
As DI_PNP	Switch-on level $\geq 4,6 \text{ V}$ Switch-off level $\leq 1,6 \text{ V}$ Input resistance $\geq 35 \text{ k}\Omega$ Input frequency max. 10 Hz

4.4.2.2 Analog PT1000 input (AI_PT1000) can be configured as:

Characteristics	Description, value, unit
Analog inputs	Abbreviation AI_PT1000 Quantity 1 Measuring range $-45 \text{ }^\circ\text{C} \dots +150 \text{ }^\circ\text{C}$ Resolution and Accuracy $\pm 1\%$ Terminal/connection between AI_PT1000 and GND_PT1000

4.4.2.3 Digital inputs (DI) can be configured as:

Characteristics	Description, value, unit
Digital inputs with frequency measurement	Abbreviation DI Quantity 8 Pulldown resistor $< 5,6 \text{ k}\Omega$ Switch-on level $\geq 4,6 \text{ V}$ Switch-off level $\leq 1,6 \text{ V}$ Input frequency 0,1Hz...10 kHz Dielectric strength max. 32 V

4.4.2.4 Configuration inputs (CFG1_IN, CFG2_OUT) can be configured as:

Characteristics	Description, value, unit
Configuration inputs for configuring the node ID	Abbreviation CFG1_IN, CFG2_OUT Quantity 2

4.4.3 Inputs EBM-220000

4.4.3.1 Analog inputs (AI) can be configured as:

Characteristics	Description, value, unit	
Analog inputs	Abbreviation	AI
	Quantity	8
	Resolution	12 bit
Voltage measurement	Rated measuring range	0...10V
	Overvoltage measurement	10...12 V
	Input resistance	$\geq 43 \text{ k}\Omega$
	Load resistor	120 Ω
	Maximum voltage	32 V
	Measuring accuracy	$\pm 1,5\%$ relative to the rated measuring range 12 V
Moving average filter	Filter depth range	1...32 (At 1 no filtering is active)
	Measuring cycle	1 ms
Current measurement	Measuring range	0...20 mA
	Overcurrent range	21...24 mA
	Measuring accuracy	$\pm 1\%$ relative to the current measurement range 20 mA
	Overcurrent detection limits	the current so that the device is not damaged.
Sample time	Sample time	2 ms
As AI_PT1000	Measuring range	-45 °C...+150 °C
	Resolution and accuracy	$\pm 1\%$
	Terminal/connection	Between AI_x and any GND_SEN
As DI_PNP	Switch-on level	$\geq 4,6 \text{ V}$
	Switch-off level	$\leq 1,6 \text{ V}$
	Input resistance	$\geq 43 \text{ k}\Omega$
	Input frequency	max. 10 Hz

4.4.3.2 High-precision analog inputs (AI_PREC) can be configured as:

Characteristics	Description, value, unit	
High-precision analog inputs	Abbreviation	AI_PREC
	Quantity	2
	Resolution	16 bit
	Dielectric strength	max. 32 V
Current measurement	Measuring range	0...20 mA
	Overcurrent range	21...24 mA
	Measuring accuracy	$\pm 0,5\%$ relative to the current measurement range 20 mA
	Overcurrent detection limits	the current so that the device is not damaged.
Sample time	8 ms until AI_PREC_1 and AI_PREC_2 are activated. 2 ms if only one AI_PREC is used.	

4.4.3.3 Digital inputs (DI) can be configured as:

Characteristics	Description, value, unit
Digital inputs with frequency measurement	Abbreviation DI Quantity 6 Pulldown resistor < 5,6 kΩ Switch-on level ≥ 4,6 V Switch-off level ≤ 1,6 V Input frequency 0,1Hz...10 kHz Dielectric strength max. 32 V

4.4.3.4 Configuration inputs (CFG1_IN, CFG2_OUT) can be configured as:

Characteristics	Description, value, unit
Configuration inputs for configuring the node ID	Abbreviation CFG1_IN, CFG2_OUT Quantity 2

4.5 Output Characteristics

4.5.1 Outputs EBM-200000

4.5.1.1 Output PWMi_H3 can be configured as:

Characteristics	Description, value, unit
High-side PWM output with precise current diagnostics	Abbreviation PWMi_H3 Quantity 4 Peak current 3 A per channel Load range 0,02...3 A per channel Properties: No-load detection, compatible with inductive load, overcurrent detection, precise current measurement
Pulse width modulation	PWM frequency max. 1500 Hz Resolution 0,1 % Dither frequency 50...200 Hz Dither amplitude 0...20 %
Current control	PID controller with configurable control parameters control period ≥ 5 ms, adjustable
Current diagnostic	Resolution 12 bit Measuring range 0,2...4 A Measuring accuracy ±2,5% of the maximum value referred to the current range 3 A
Use as input	NPN and PNP input Switching the interface to NPN or PNP affects the entire PWMi_H3_x group! Switch-on level ≥ 4,6 V Switch-off level ≤ 1,6 V Input resistance PNP = 94 kΩ / NPN = 10 kΩ

4.5.1.2 Output PWM_H7 can be configured as:

Characteristics	Description, value, unit	
High-side PWM output with current diagnostics	Abbreviation Quantity Peak current Load range Properties:	PWM_H7 6 7 A per channel 0,2...7 A per channel No-load detection, compatible with inductive load, overcurrent detection
Pulse width modulation	PWM frequency Resolution	min. 5 Hz / max. 1500 Hz 0,1 %
Current diagnostic	Diagnostics value < 0,2 A ≤ 1,5 A > 1,5...7 A Related to the measuring range 7 A	Measuring accuracy ±45 % ±35 % ±25 %
Use as input	NPN and PNP input Switch-on level Switch-off level Input resistance	Switching the interface to NPN or PNP affects the entire PWM_H7_x group! ≥ 4,6 V ≤ 1,6 V PNP = 94 kΩ / NPN = 10 kΩ

4.5.1.3 Output DO_H3 can be configured as:

Characteristics	Description, value, unit	
Digital output with current diagnostics	Abbreviation Quantity Peak current Total current Switch load On/Off switching frequency Properties:	DO_H3 4 3 A per channel max. 6 A for all 4 channels 0,02...3 A max. 50 Hz No-load detection, compatible with inductive load, overcurrent detection
Current diagnostic	Current < 0,2 A ≤ 1,5 A > 1,5...3 A Related to the measuring range 3 A	Measuring accuracy ±45 % ±35 % ±25 %
Use as input	NPN and PNP input Switch-on level Switch-off level Input resistance	Switching the interface to NPN or PNP affects the entire DO_H3_x group! ≥ 4,6 V ≤ 1,6 V PNP = 94 kΩ / NPN = 10 kΩ

4.5.1.4 Sensor output VEX_SEN can be configured as:

Characteristics	Description, value, unit	
Output for supplying sensors: VBAT_ECU is looped through to VEXT_SEN via a PTC resistor. An overcurrent or short circuit at the sensor supply can be detected.	Abbreviation Quantity Peak current	VEXT_SEN 3 min. 100 mA per channel at 85 °C ca. 500 mA per channel at 25 °C

4.5.2 Outputs EBM-210000

4.5.2.1 Output PWMi_H3 can be configured as:

Characteristics	Description, value, unit
High-side PWM output with precise current diagnostics	Abbreviation PWMi_H3 Quantity 4 Peak current 3 A per channel Load range 0,02...3 A per channel Properties: No-load detection, compatible with inductive load, overcurrent detection, precise current measurement
Pulse width modulation	PWM frequency max. 1500 Hz Resolution 0,1 % Dither frequency 50...200 Hz Dither amplitude 10...90 %
Current control	PID controller with configurable control parameters control period ≥ 5 ms, adjustable
Current diagnostic	Resolution 12 bit Measuring range 0,2...3 A Measuring accuracy $\pm 2,5\%$ of the maximum value referred to the current range 3 A
Use as input	PNP input Switch-on level $\geq 4,6$ V Switch-off level $\leq 1,6$ V

4.5.2.2 Output PWMi_HL5 can be configured as:

Characteristics	Description, value, unit
PWM half-bridges up to 5 A with current monitoring	Abbreviation PWMi_HL5 Quantity 4 Peak current 5 A per channel Load range 0,02...5 A per channel Properties: No-load detection, compatible with inductive load, overcurrent detection
Pulse width modulation	PWM frequency 10 Hz ... 1 kHz Resolution 0,1 % PWM frequency 1 kHz ... 5 kHz Resolution 1 %
Current diagnostic	Resolution 12 bit Measuring range 0 A...7,5 A Measuring accuracy $\pm 15\%$

4.5.2.3 Output PWMi_HL12 can be configured as:

Characteristics	Description, value, unit	
PWM half-bridges up to 12 A with current monitoring	Abbreviation	PWMI_HL12
	Quantity	4
	Peak current	12 A per channel
	Load range	0,02...12 A per channel, 30 A peak load
	Properties: compatible with inductive load, overcurrent detection, current measurement	
Pulse width modulation	PWM frequency	10 Hz ... 1 kHz
	Resolution	0,1 %
	PWM frequency	1 kHz ... 15 kHz
	Resolution	1 %
	min. PWM frequency	10 Hz
Current diagnostic	Resolution	12 bit
	Measuring range	0...15 A
	Measuring accuracy	± 15%

4.5.2.4 Sensor output VEX_SEN can be configured as:

Characteristics	Description, value, unit	
Output for supplying sensors.	Abbreviation	VEXT_SEN
	Quantity	1
Operating voltage	Operating voltage	10 V
	Quantity	1%
Operating current	Operating current	min. 100 mA
	Accuracy	1%
Diagnostic	The voltage generated at the 10 V power supply can be read out via SDO. Each channel can be checked for short circuit.	

4.5.3 Outputs EBM-220000

4.5.3.1 Analog outputs (AO) can be configured as:

Characteristics	Description, value, unit	
High-side PWM output with precise current diagnostics	Abbreviation	AO
	Quantity	3
	Mode	0...20 mA or 0...10 V: max. 20 mA
	It is possible to switch between the configuration as current output or voltage output.	
	Accuracy (current)	±2,5% of the value range
	Accuracy (voltage)	100 mV
	Resolution	12 bit configured in mV

4.5.3.2 Outputs VREF_10 V can be configured as:

Characteristics	Description, value, unit	
Output for supplying sensors.	Abbreviation	VREF_10V
	Quantity	2
Operating voltage	Operating voltage	10 V
	Quantity	1%

Characteristics	Description, value, unit
Operating current	Operating current min. 100 mA Accuracy 1%
Diagnostic	The voltage generated at the 10 V power supply can be read out via SDO. Each channel can be checked for short circuit.

4.5.3.3 Sensor output VEX_SEN can be configured as:

Characteristics	Description, value, unit
VEXT_SEN is the 24 V output for supplying power to external sensors and is supplied from VBAT_ECU.	Abbreviation VEXT_SEN Quantity 1
Operating voltage	Operating voltage VBAT Quantity 1%
Operating current	Operating current 100 mA Accuracy 1%
Diagnostic	Each channel can be checked for short circuit.

4.6 Dimension

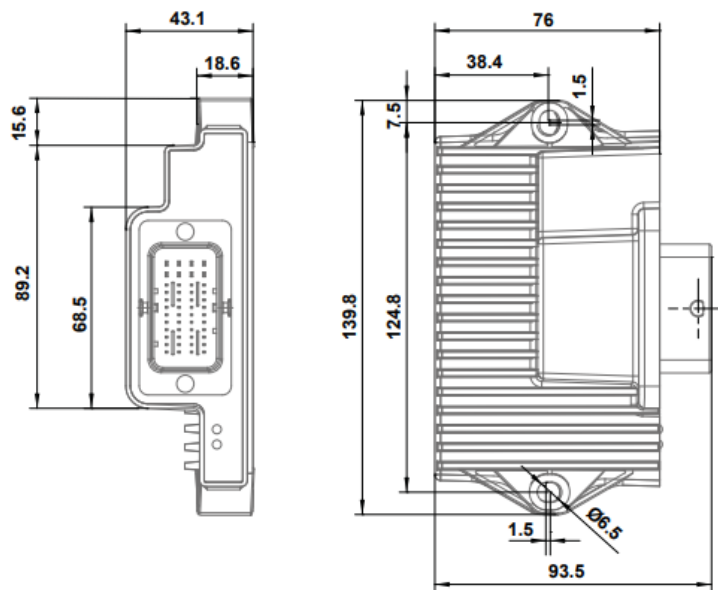

4.7 Connector pinout

The pins of lines A to K drive up to 6 A, the pins of lines L to M drive up to 12 A.

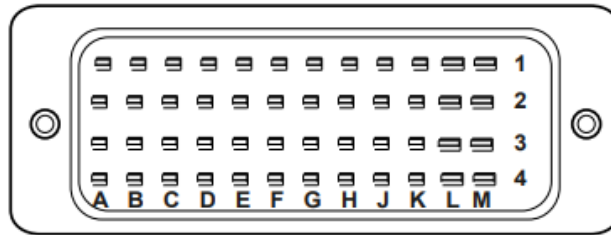

4.7.1 Connector pinout EBM-200000

	4	3	2	1
A	PWM_H7_5	n. c.	CAN_TERM2	CAN_H
B	PWM_H7_5	AI_1	CAN_TERM1	CAN_L
C	PWM_H7_6	AI_2	DI_P_1	PWMI_H3_4
D	PWM_H7_6	AI_3	DI_P_2	PWMI_H3-3
E	PWM_H7_4	AI_4	DI_P_3	PWMI_H3_2
F	PWM_H7_4	AI_5	DI_P_4	PWMI_H3_1
G	PWM_H7_3	AI_6	GND_SEN	DO_H3_4
H	PWM_H7_3	AI_7	VEXT_SEN_3	DO_H3_3
J	CFG1_IN	AI_8	VEXT_SEN_2	DO_H3_2
K	CFG2_OUT	VBAT_ECU	VEXT_SEN_2	DO_H3_1
L	GND_PWR	GND_PWR	VBAT_PWR	VBAT_PWR
M	GND_PWR	GND_H7_2	PWM_H7_1	VBAT_PWR

4.7.2 Connector pinout EBM-210000

	4	3	2	1
A	n. c.	n. c.	CAN1_TERM2	CAN1_H
B	n. c.	AI_1	CAN1_TERM1	CAN1_L
C	n. c.	AI_2	DI_1	PWMI_HL5_1
D	n. c.	AI_3	DI_2	PWMI_HL5_2
E	PWMI_H3_1	AI_4	DI_3	PWMI_HL5_3
F	PWMI_H3_2	AI_5	DI_4	PWMI_HL5_4
G	PWMI_H3_3	AI_6	GND_SEN	DI_5
H	PWMI_H3_4	AI_PT1000	VREF_SEN	DI_6
J	CFG_1	GND_PT1000	VEXT_SEN_1	DI_7
K	CFG_2	VBAT_ECU	VEXT_SEN_2	D_8
L	GND	PWMI_HL12_4	PWMI_HL12_1	VBAT_PWR
M	GND	PWMI_HL12_3	PWMI_HL12_2	VBAT_PWR

4.7.3 Connector pinout EBM-220000

	4		2	
A	DI_1	n. c. (BOOT)	CAN1_TERM2	CAN1_H
B	DI_2	AO_3	CAN1_TERM1	CAN2_L
C	DI_3	GND_SEN	VEXT_SEN_1	AI_1
D	DI_4	GND_SEN	VEXT_SEN_2	AI_2
E	DI_5	GND_SEN	VEXT_SEN_3	AI_3
F	DI_6	GND_SEN	VEXT_SEN_4	AI_4
G	AO_1	GND_SEN	VEXT_SEN_5	AI_5
H	AO_2	GND_SEN	VEXT_SEN_6	AI_6
J	CFG1_IN	GND_SEN	VEXT_SEN_7	AI_7
K	CFG2_OUT	VBAT_ECU	GND_SEN	AI_8
L	VEXT_SEN_8	GND_SEN	VREF_10V_1	AI_PREC_1
M	GND	GND_SEN	VREF_10V_2	AI_PREC_2

4.7.4 Abbreviation used in this document

PWM_H7 = High-side PWM output up to 7 A
 VEXT_SEN = Sensor supply protected by PTC resistor
 DO_H3 = Digital high-side output
 PWMI_H3 = High-side PWM output up to 3 A with precise current measurement
 DI_P = Digital and frequency input
 DI_P_1 = Digital and frequency input which can also be used as NPN input as of HW Rev. 02.00
 AI = Analog input, current/voltage
 AI_PREC_X = Analog input with high resolution (16 bit)
 AO_X = Analog output
 VBAT_ECU = Power supply for logic unit and sensors
 VBAT_PWR = Power supply for output driver
 GND_PWR = Ground - power outputs
 GND_SEN = Ground - sensor power supply
 CAN_TERMx = These two pins must be jumpered to enable the 120 Ω terminating resistor.
 CFG = Configuration pin for setting the CAN-ID
 IN_CFG_X = Configuration pin for setting the CAN-ID
 OUT_CFG_X = Configuration pin for setting the CAN-ID
 VREF_10V_X = Stabilized reference voltage for sensors
 n. c. = Reserved pin that must not be connected.

4.8 Diagnostic

Color	Blinking pattern	Description
Red	Permanently ON	Operating voltage is present. The bootloader is not working.
Red	ON: 200 ms OFF: 200 ms	Bootloader is working. The device has no firmware.
Red	ON: 400 ms OFF: 400 ms	The start process is completed without errors. The device is in the Stopped state.
Green	ON: 200 ms OFF: 200 ms	The start process is completed without errors. The device is in the Pre-Operational state.
Green	ON: 200 ms OFF: 600 ms	The start process is completed without errors. The device is in the Operational state.
Green	3x ON/OFF 200 ms Break 400 ms	The start process is completed without errors. The device is in calibration mode.
Red Green	ON: 200 ms OFF: 400 ms	The device is in the Bus Off state. Bus communication is not possible. There is a wiring error.
Red	3x ON/OFF 200 ms	Measured values are outside their specified ranges. The following errors may have occurred:
Green	ON: 400 ms OFF: 400 ms	- The PCB temperature is too high - The CPU temperature is too high - the maximum total current consumption is exceeded.

4.9 Ordering Informations

4.9.1 Ordering informations Multifunction card

Type	Model code	Part number
Multifunction card	EBM-200000	Part number is assigned when the order is placed.
Multifunction card	EBM-210000	Part number is assigned when the order is placed.
Multifunction card	EBM-220000	Part number is assigned when the order is placed.

5 EBM-800 Master module



- 32-bit controller, 500 MHz
- Programming according IEC 61131 STX or C
- Modular configuration for high flexibility
- CAN-, USB-, LIN- and RS232 interfaces for high connectivity
- Compact and robust design
- CE, E1 Certificat

5.1 Description

5.1.1 Basic controller

The partially modular designed compact controller EBM-800 having got modular design. Due to its vast I/O capacity featuring high-performance H-bridges, PWM outputs, flexibly applicable inputs and high total electric currents, even ist basic configuration is already sufficient for numerous applications. Besides hydraulic actuators, it can even directly control electric motors. Expandability by 2 MX modules allows for easily adjusting to a great variety of functions and applications.

Besides standard ports and interfaces, the EBM-800 is equipped with inputs apt for Namur, as well as with a LIN port. This way, it can be integrated into almost any systems architecture. The high-level language STX to IEC61131-3 lets you represent virtually any control task. Programming in C is possible, too.

5.1.2 MX module

MX modules are configurable multipurpose add-on modules for the EBM-800 controllers. Bucher Hydraulics supplies

the EBM-800 in different versions with 1 or 2 additional integrated MX modules.

5.2 Application examples

- Agricultural machinery
- Forestry machines
- Municipal equipment technology
- Transport and material handling
- Construction equipment
- Road-construction machinery

5.3 Technical Data

5.3.1 Basic controller

Electrical Characteristics	Unit	Description, value
CPU		ARM11, 32-bit, 500 MHz
Memory		128 MB RAM, 512 MB Flash, 128 kB MRAM
Peripheral devices		FPGA
Programming		IEC 61131-3 STX, C
Operating system		WinCE 6.0
Supply voltage	V DC	8...32
Operating/storage temperature	°C	-40...+85
Protection class		IP 65, IP 67
Reference voltage	V DC	5 or 10, to be switched over depending on software configuration

Electrical Characteristics	Unit	Description, value
Max. permitted total current	A	30, temporarily 60
Vibration		ISO 016750-3, 10...150 Hz, 6h
Shock		ISO 016750-3, 50 g, 18 ms, 10 x 6
Interfaces:		
CAN		2x 125 kB/s...1 MB/s CANopen , SAE J1939, ISO BUS 11783
USB		1x USB 2.0
RS232		1x 9,6 kB/s - 115 kB/s
LIN		1x 9,6 kB/s - 115 kB/s
Ethernet		1x optional
Operation and diagnostic		2x Status-LEDs
RTC		optional
Max. Number of inputs and outputs		40
Max. Number of MX modules (expansion)		2x Up to 8 inputs/outputs per MX module. For possible configurations see descript MX modules.
Safety relay in load circuit		Yes, PWM outputs can be disable
Diagnostic/Safety		Total current monitoring w protection against polarity reversal w overload and no-load detection w all I/Os are protected against short circuit to GND and Ub

5.4 Input Characteristics

5.4.1 Analog inputs (AI) configured as:

Characteristics	Description, value, unit	
	Abbreviation	AI
	Quantity	8
	Resolution	12 bit
Voltage measurement	Rated measuring range	0...5,7 V
	Overvoltage measurement	10...22 V
	Input impedance	75 k Ω
	Load resistor	120 Ω
Current measurement	Measuring range	0...20 mA
	Overcurrent range	21...24 mA
	Measuring accuracy	\pm 1% relative to the current measurement range 20 mA
	Overcurrent detection limits the current so that the device is not damaged.	
Alternative usage: NAMUR input with a bias voltage of 8.2 V; Digital input active-high, input impedance 50 k Ω ; Frequency input, 0.1...10 kHz , period > 1 μ s		

5.4.2 Digital inputs (DI) configured as:

Characteristics	Description, value, unit	
Digital inputs active high	Abbreviation	DI
	Quantity	8
	Input impedance	50 k Ω
Alternative usage as frequency input: Frequency input: 0,1...10 kHz , period > 1 μ s		

5.5 Output Characteristics

5.5.1 High-side PWM outputs inputs (PWM_H) configured as:

Characteristics	Description, value, unit
High-side PWM output	Abbreviation AO Quantity 4 PWM frequency 10 Hz...1 kHz Resolution 1% Alternative usage as digital output: Digital output 3,5 A high-side
PWM H-bridge up to 15 A	Abbreviation PWM_HL Quantity 2 Peak current 15 A per channel Alternative usage as: 4x PWM output: PWM frequency 10 Hz...1 kHz Peak current 15 A per channel 4x Digital output: Digital output 15 A high-side 4x Digital output: Digital output 15 A low-side

5.5.2 PWM H-bridge (PWM_HL) configured as:

Characteristics	Description, value, unit
PWM H-bridge up to 15 A	Abbreviation PWM_HL Quantity 2 Peak current 15 A per channel Alternative usage as: 4x PWM output: PWM frequency 10 Hz...1 kHz Peak current 15 A per channel 4x Digital output: Digital output 15 A high-side 4x Digital output: Digital output 15 A low-side

5.5.3 MX-Module configured as:

Characteristics	Description, value, unit
PMX-Module	Abbreviation PWMi Quantity 8 Peak current 32 A PWM frequency 10 Hz...1 kHz Load range 3,5 A per channel Resolution 10 bit Safety relay in load circuit yes
Diagnostic	Open load, short circuit, current measuring (1%)

5.6 Dimension

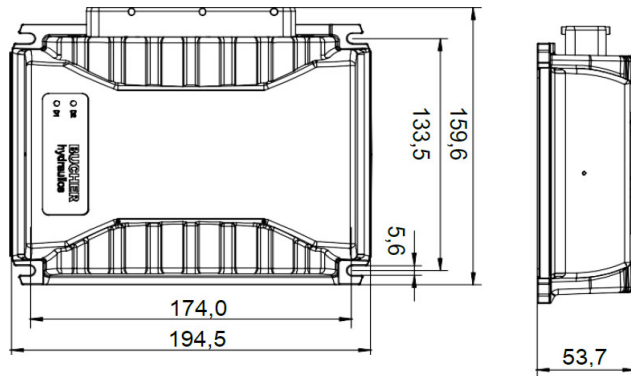

5.7 Connector pinout

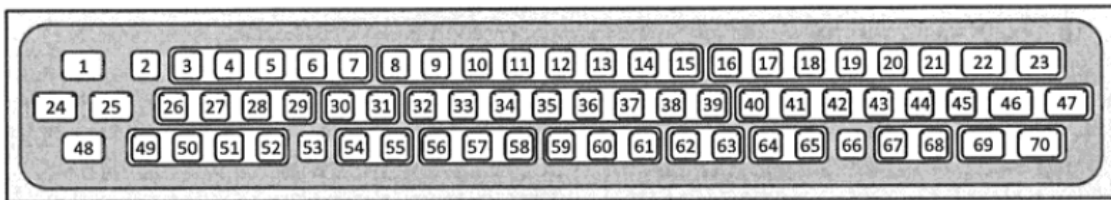

Pin	Pin Description	Pin	Pin Description	Pin	Pin Description	Pin	Pin Description	Pin	Pin Description
1	H-bridge 1A, max. 15A	15	Multi function input 2	29	CAN2-H	43	MX module 2 - Port 3	57	MX module 1 - Port 6
2	Power ON	16	Multi function input 3	30	Digital input 1	44	MX module 2 - Port 6	58	MX module 1 - Port 5
3	Power supply logic	17	Multi function input 4	31	Digital input 2	45	MX module 2 - Port 7	59	MX module 1 - Port 4
4	CAN1-L	18	Multi function input 5	32	Digital input 3	46	Supply power outputs	60	LIN
5	CAN1-H	19	Multi function input 6	33	Digital input 4	47	Ground	61	RS232-RX
6	PWM3	20	Multi function input 7	34	Digital input 5	48	H-bridge 2B, max. 15A	62	Ground
7	PWM1	21	Multi function input 8	35	Digital input 6	49	Power supply logic	63	MX module 1 - Port 2
8	PWM2	22	Supply of power outputs	36	Digital input 7	50	Supply release relay	64	Ground
9	PWM4	23	Ground (power outputs)	37	Digital input 8	51	n. c.	65	Ground
10	USB + 5V	24	H-bridge 1 B, max. 15 A	38	RS232-TX	52	n. c.	66	MX module 2 - Port 8
11	USB Dp	25	H-bridge 2A, max. 15A	39	Ground	53	MX module 1 - Port 2	67	MX module 2 - Port 4
12	USB D _M	26	Ground	40	Ground	54	MX module 1 - Port 3	68	MX module 2 - Port 5
13	Output reference voltage	27	Input for release relay	41	MX module 2 - Port 1	55	MX module 1 - Port 8	69	Supply power outputs
14	Multi function input 1	28	CAN2-L	42	MX module 2 - Port 1	56	MX-Modul 1 - Port 7	70	Ground

5.8 Ordering information

5.8.1 Basic controller

Description	Item number	PWMi	HB	CAN	Serial	MFQE	DIN
EBM-800 Master module	100036918	4	2	2	1	8	8

5.8.2 Controller with additional MX modules

Description	Item number	PWMi	HB	CAN	Serial	MFQE	DIN	
EBM-810 Master module	100036919	12	2	2	1	8	8	1
EBM-820 Master module	100036920	20	2	2	1	8	8	2

5.8.3 Connector and cable

Description	Type	Part number
Wiring harness: AMP connector, 70 free cable, 1,5 meters long, open cable ends	EBM-8 wiring harness	100037706
AMP connector housing, JPT/micro timer 2, socket, 70-pole	AMP connector	100037705

info.kl@bucherhydraulics.com

www.bucherhydraulics.com

© 2022 by Bucher Hydraulics GmbH, D-79771 Klettgau

All rights reserved.

Data is provided for the purpose of product description only, and must not be construed as warranted characteristics in the legal sense. The information does not relieve users from the duty of conducting their own evaluations and tests. Because the products are subject to continual improvement, we reserve the right to amend the product specifications contained in this catalogue.

Classification: 470.710..