

BUCHER
hydraulics

Efficient System Solutions for the Electrification of Mobile Machines



OIL SOLUTIONS

With coordinated mobile hydraulics to high performance and profitability

PO Box 38
Strathfieldsaye, VIC, 3551
1800 OIL SOL
1800 645 765

sales@oilsolutions.com.au

www.oilsolutions.com.au

"For All Your Hydraulic Needs"

ELECTRIFICATION



Electrification Has Become a Trend

Just a passing phenomenon?

Sustainability and urbanization are two megatrends that will continue to drive the electrification and efficiency of mobile machinery. In the coming decades, this will further increase the demand for innovative solutions.

Current challenges:

- Reducing CO₂ emissions in the EU by at least 60% (by 2030)¹⁾
- Reducing energy needs and using renewable energies, see “Energy Efficiency Strategy 2050” of the German Federal Government ²⁾
- “Zero-emission” as a goal for a positive ecological footprint

As a strong partner, Bucher Hydraulics supports its customers with innovative and efficient system solutions.

HELSINKI

Has set a target for 2020, 100% of municipal tenders must take environmental criteria into account

COPENHAGEN

By 2025, all renovation projects are to be carried out based on the "low energy" principles.

AMSTERDAM

Clean Air Action Plan:
The goal is to change the entire city to "zero emission" by 2030.

CALIFORNIA

E-quotas for commercial vehicles as of 2024.
As of 2045, only emission-free commercial vehicles are to be admitted!

LONDON

Increases the requirements concerning "Low Emission Zones".

CHINA

At least 80% of the new public bus fleets are to be emission-free by the end of 2020.
However, some cities have set a target of 100%.

¹⁾ European Parliament (2018); Reducing CO₂ emissions; EU-climate objectives and provisions

²⁾ Climate Action Plan 2015 (2016); Climate protection political principles and objectives of the Federal Government BMU

The main topic

Smart Electrohydraulics as a Success Factor

Increased efficiency with optimal hydraulic systems

In the electrification process, many machine manufacturers focus on the traction drives, but often pay too little attention to the existing hydraulics.

Classic hydraulic drive and control solutions for mobile machines are often designed to reduce initial costs rather than efficiency. This provides an opportunity to offer energy-saving potential of up to 60 %.

Benefits thanks to coordinated system components:

- Savings potential for battery and operating costs due to the reduced energy demand of fine-tuned hydraulic systems
- New application possibilities thanks to reduced noise emissions
- Greater range and longer operating times with the same battery size
- High energy efficiency and durability serve as a basis for successful electrification

All these advantages have a positive effect on life cycle costs.

Conventional hydraulics

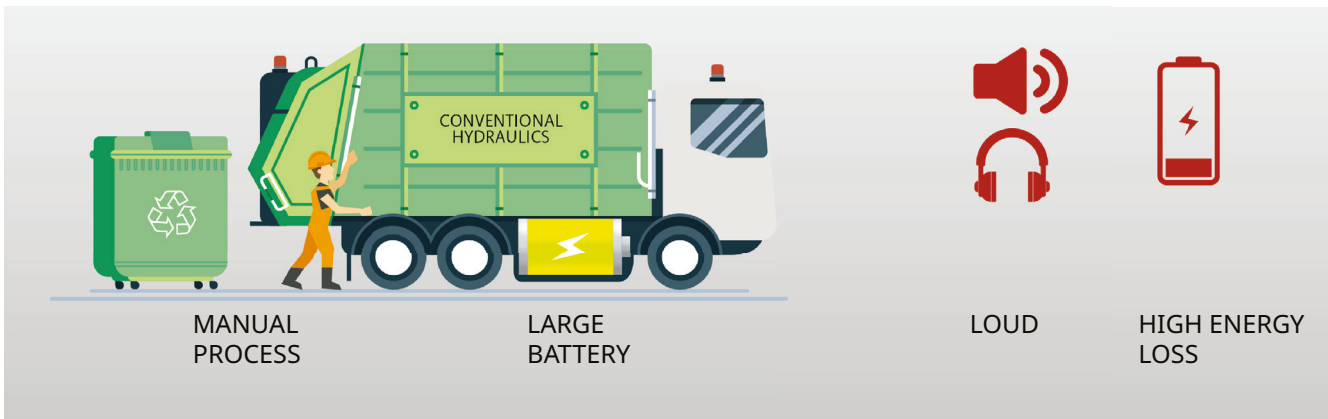

Advanced electrohydraulics

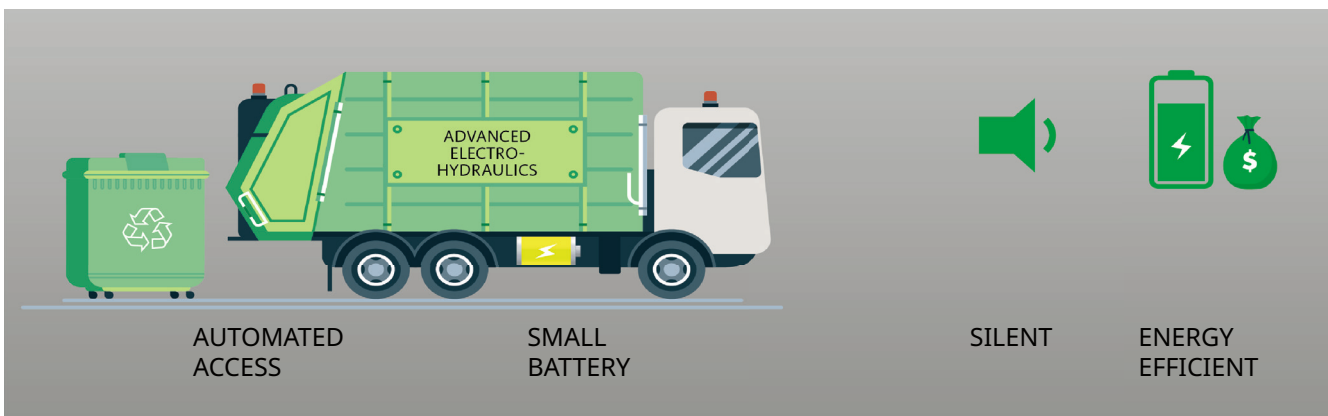



Approach based on HELAX

HELAX – The smart solution to lift and lower loads

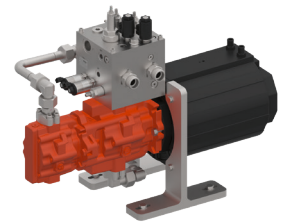

HELAX

Massive energy savings thanks to recuperation

The hydraulic-electric linear axis with AX technology (HELAX) offers enormous energy savings compared to traditional load-sensing working hydraulics. Electrical energy is produced and fed back into the battery when heavy loads are lowered.

HELAX properties:

- Maximum efficiency thanks to new AX pump and elimination of valve technology
- Recuperation of energy during lowering due to innovative system architecture
- Compliance with safety standards

We address to your individual requirements and needs and work with you to determine the highest value system for you.

System comparison: number of possible cycles (lifting & lowering) with constant battery capacity

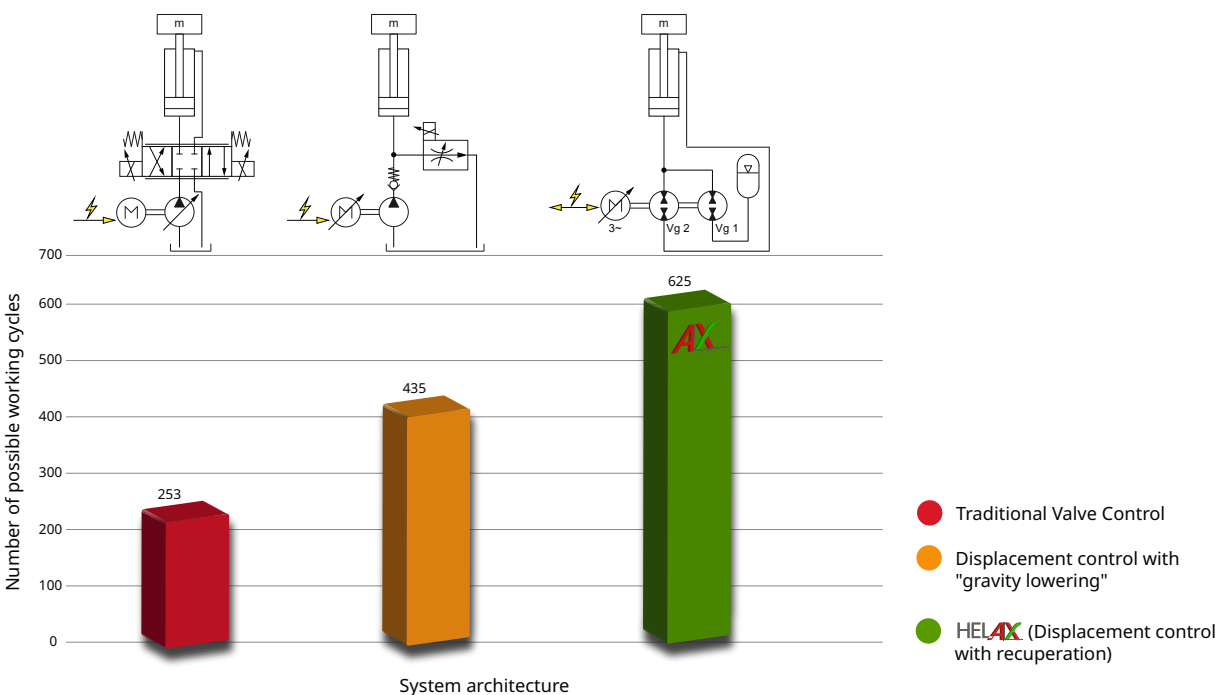

HELAX Variants

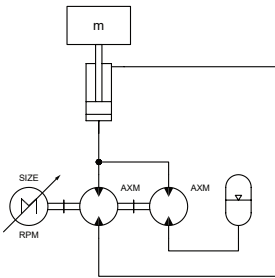

Standard configuration

- Hydraulic & electric recuperation
- AX double pump

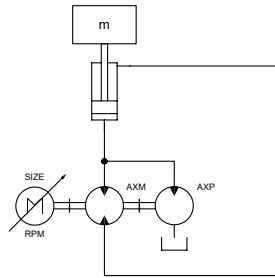

No hydraulic accumulator

- Electric recuperation only
- Less space requirements
- Larger power electronics

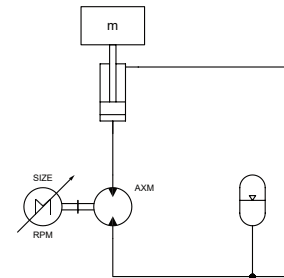

2 Quadrant HELAX

- Gravity lowering only
- AX single pump
- Less components

Impact of the system architecture on the energy demand

In order to achieve high cost-effectiveness, longer service life as well as reduced energy consumption, efficient, coordinated hydraulic components are of crucial importance.

We offer you innovative solutions for the electrification of mobile machines.

Energy reduction

Longer operating time

Cost and time savings

1 working cycle
57% energy reduction

Demand-based
volume flow control

Power-on-Demand System Solution

Success factors

Energy efficiency, noise emission, uprating and total operating costs depend largely on the system architecture as well as on the components used. Bucher Hydraulics has several Power-on-Demand system architectures such as Flow-on-Demand, Negative-Flow-Control or Negative-Bypass-Control.

Compared to conventional valve control, Flow-on-Demand solutions in particular offer many advantages:

- Simple integration into existing machine concepts
- Rapid acceleration and precise load control
- No susceptibility to oscillation of actuators
- Less heat loss and thus reduced cooling efforts
- Low noise emissions

Together we will find a customized solution for your needs. You will be convinced by the main benefits such as increased efficiency, noise reduction and system stability. Combining your system with our AX pump can drive the electrification of your mobile machines forward.

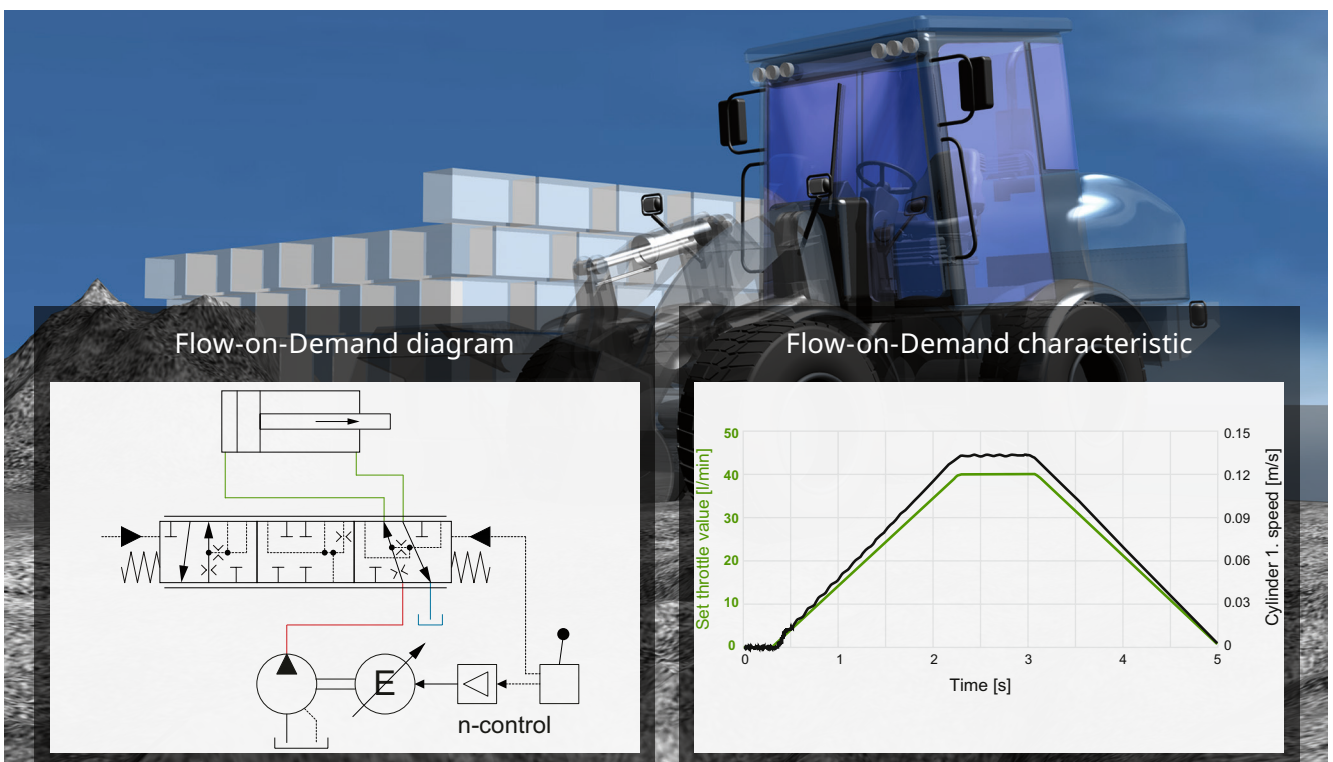

Based on Module Combination

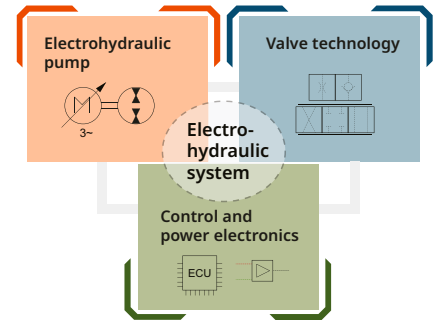

The perfect combination

To combine electric drive technology and hydraulics, various modules are combined, resulting in an electrohydraulic system solution with demand-based volume flow control.

Typical combination of a Flow-on-Demand system solution

Main components:

- Electrohydraulic pump (EHP) with suitable inverter
- Valve technology with Flow-Sharing principle
- Electronic control unit (ECU) with Flow-on-Demand software

The foundation of a unique, optimally tuned system architecture produces a decisive increase in efficiency and cost-effectiveness.

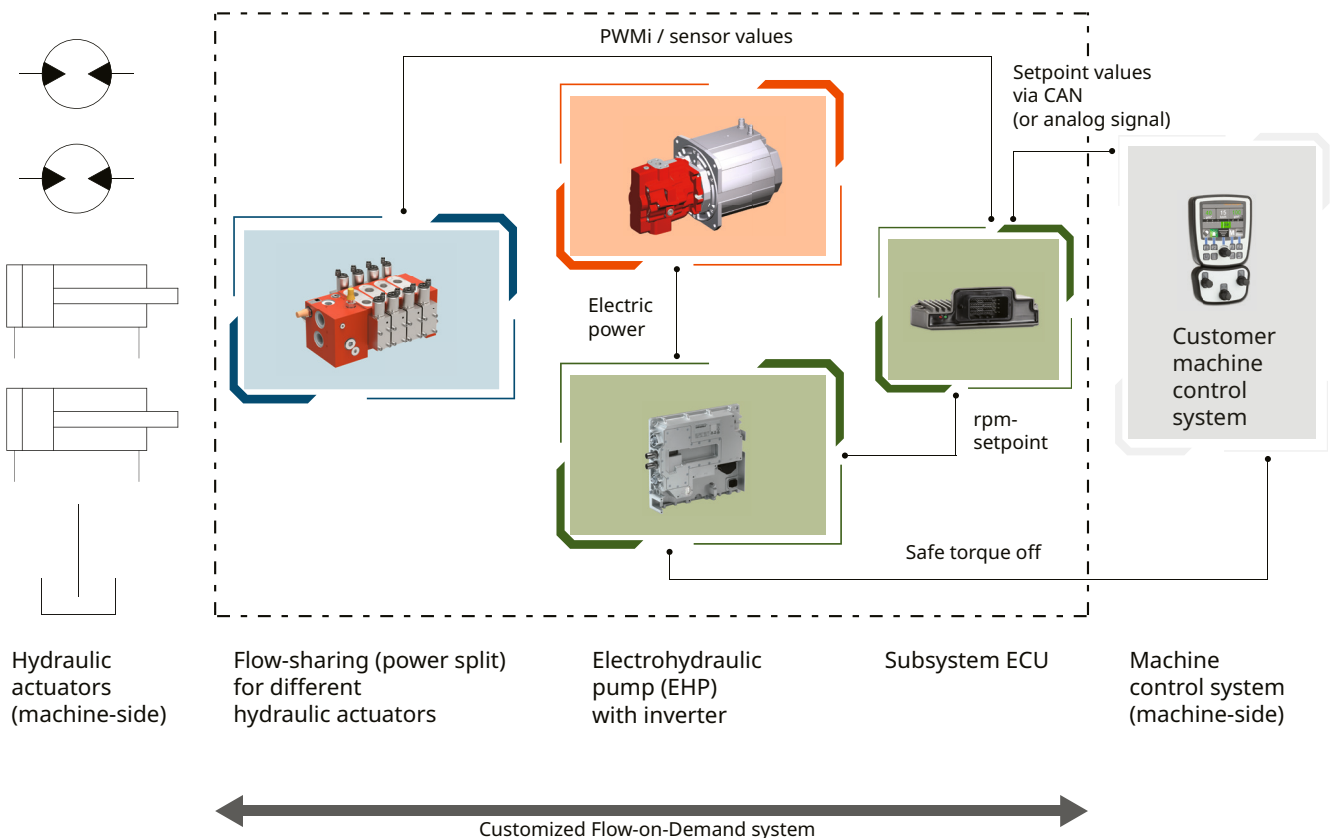

Low Voltage Applications

Smart PowerPack „S“ Set, Connect – Runs!

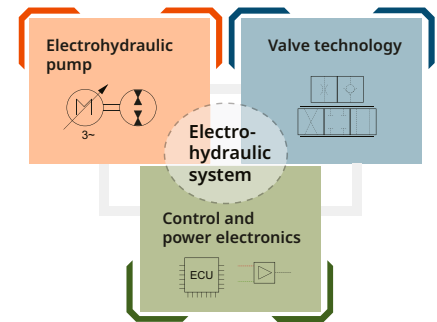

One for all

The Smart-PowerPack system is a small Power-on-Demand unit for providing hydraulic power. It combines a variety of technologies to create a system that allows for interchangeability across multiple applications. The system is able to sense the application it is connected to and modify its operating parameters and user interface accordingly.

Features and components

- Negative-Bypass-Control (NBC) as Power-on-Demand technology.
- Brushless electric motor for long-life, maintenance-free operation
- Temperature sensor for protection against overheating
- Quiet, compact, efficient, durable and precise
- Digital Controls sets system parameters based on application sense function
- System also available as distributed design

Advantages

- User-friendly 7" touchscreen with info to connected application
- Suitable for electric vehicles (zero greenhouse gas emissions)
- Highly efficient components
- Significant noise reduction
- Hydraulic and electric in one easy connection
- Open standards such as CANbus and Bluetooth
- Communication through user inputs or other systems



Technical data

	Operating flow max.	Operating pressure max.	Tank-volume	Peak supply
Metric	14.4l/min	230 bar	5l	58VDC

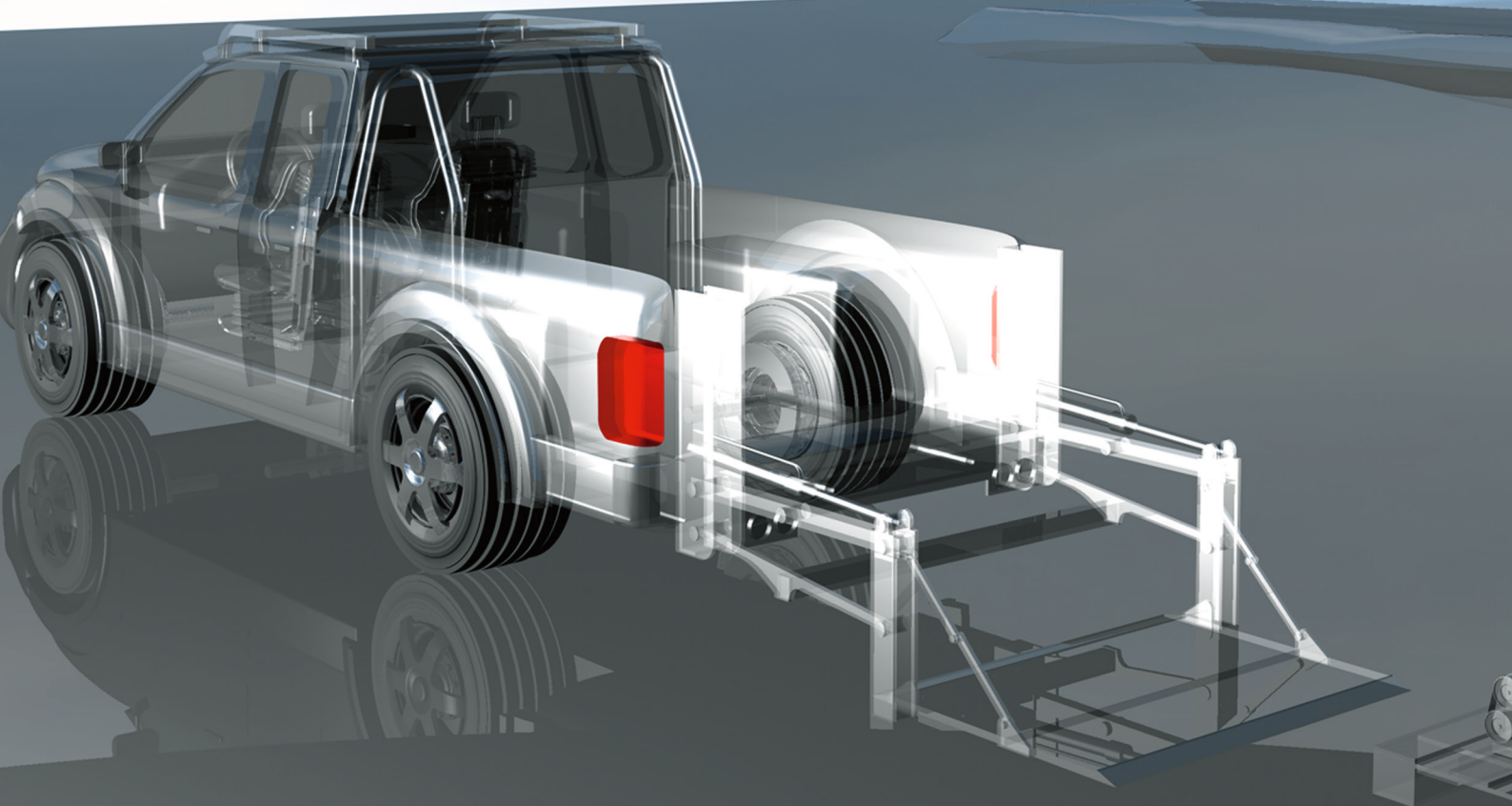

High Voltage Applications

Smart PowerPack „L“ The eh-PTO Solution

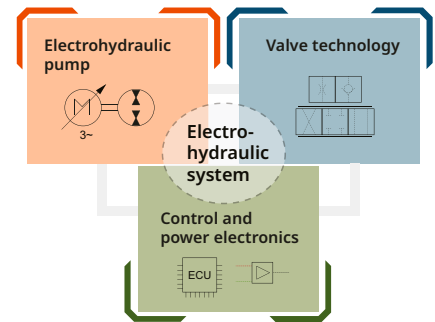

Electrification made easy

To reduce CO₂ emissions, commercial vehicle manufacturers will remove mechanical V-belts or power take-offs (PTO) in the future. Our electrohydraulic Power-on-Demand systems close this emerging gap.

The Smart PowerPack “L” is a construction kit for the power range from 15 - 60 kW and voltages above 400 VDC. In addition to power electronics in various sizes, the kit also includes several pump series from Bucher Hydraulics, offering great flexibility to meet a wide range of applications. Options also include a closed cooling system for the power electronics.

Advantages:

- Install, connect - it's up and running!
- Careful use of battery capacity due to demand-based volume flow provision.
- Reduced cooling requirements of the hydraulic oil
- Lower diesel consumption due to decoupled auxiliary drive
- Lower noise emissions during work functions allow new fields of application

Features and components

- Replaces an LS pump on the diesel engine
- Automatic speed control through Negative-Bypass-Control (NBC) technology
- Easy switching between open-center and closed-center systems
- Cooling system for power electronics as option
- Also available as distributed design

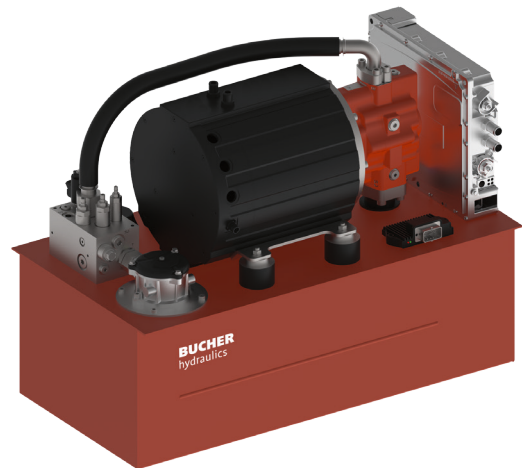

Technical data

	Operating flow max. l/min	Operating pressure max. bar	Continuous power kW	Peak power kW
400 VDC	80	265	24	25
650 VDC	140	330	40	45
800 VDC	140	330	50	60



Individual System Analysis – Our Strong Point



Increased efficiency with coordinated system architecture

Bucher Hydraulics provides support with new, electro-hydraulic system architectures, which are ideally matched according to technical and economic criteria.

Optimal system analysis though:

- Recording the current state incl. the economic and technical requirements
- Accurate analysis and precise evaluation thanks to specially developed design software
- Best-fit approach for your machine

Comprehensive range of services:

- The optimization potential is checked directly on your machine using a functional model
- Supervised commissioning
- Support for series start-up after prototype release
- On-time, flawless delivery of your harmonized system solution

Our customers can rely on Bucher Hydraulics' decades of proven expertise.



High-tech at the highest level

Key Component: AX Pump

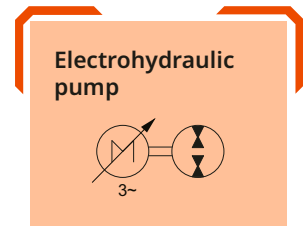

Revolutionary technology

The combination of a tuned inverter, electro motor, and a Bucher Hydraulics axial pump all work together to form the foundation for a high efficiency “Power-on-Demand” hydraulic power supply. Previous problems such as pressure pulsations, low speeds at high pressure and high power dissipation are solved with the unique AX pump.

Advantages of the innovative AX pumps and motors:

- 94% overall efficiency
- 99% start-up efficiency
- No minimum speed limit
- Low pulsations and noise level
- Low temperature increase

The unique AX pump opens up new possibilities for the electrification of mobile applications and is an ideal component in the modernization of your mobile equipment.

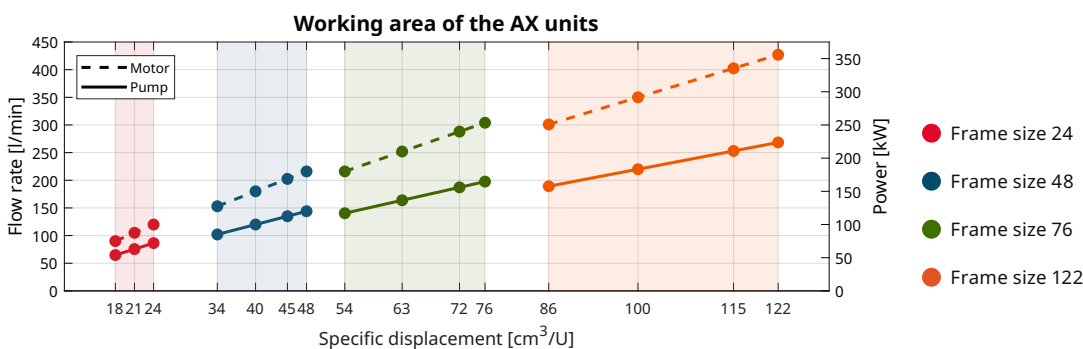

Technical data

	Displacement cm³/U	Continuous pressure max. bar	Peak pressure bar	Speed range AX pump rpm	Max. speed AX motor rpm
Size 24	18...24	450	500	0...3600	0...5000
Size 48	34...48	450	500	0...3000	0...4500
Size 76	54...76	450	500	0...2600	0...4000
Size 122	86...122	450	500	0...2200	0...3500



Frame size 24

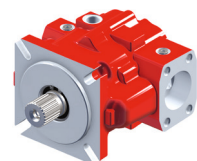

Frame size 122



Adaptability and optimal control

Valve Technology

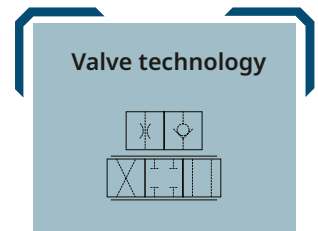

Valve technology

For decades, Bucher Hydraulics has been successfully positioning itself as a global player in the field of valve technology. With our directional valves, we offer an adaptable and comprehensive modular system to implement new innovative solutions.

Advantages of our directional valves in terms of electrification:

- Reduced energy consumption and precise positioning thanks to stepper motor drive
- Directional valves that can be combined together for flexible adaptation to various requirements
- Extremely precise control, even when operated simultaneously
- Considerably reduced energy consumption due to low pressure losses

Technical data

	Flow rate l/min	Inlet pressure bar	Actuator pressure bar
HDS14	70	280	320
HDS24	100	280	320
HDS34	150	300	350



HDS14

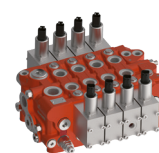

HDS24

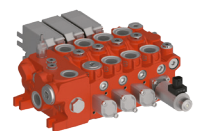

HDS34

Technical data

	Flow rate l/min	Inlet pressure bar	Actuator pressure bar
LVS08	50	250	280
LVS12	180	300	320
L.8S	90	315	315



LVS08/LVS12

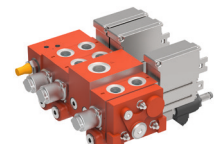

L.8S

Consistent
development

Power Electronics

Control and
power electronics

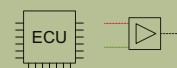

Multi-inverter and DC/DC converter

The compact MOBILE product platform from Bucher Hydraulics Mobile Drives with its multi-inverters and DC/DC converters for successful use in your commercial vehicles and mobile machinery. This has resulted in a modular drive system based on a catalog approach that minimizes the effort and time required for implementation in a vehicle concept and fulfills a key requirement with regards to the product life cycle – the reliable availability of components. Our modular system is designed to fit into your vehicle concept in terms of form and function over a long period of time.

Advantages:

- Designed specifically for use in commercial vehicles in rough environments
- Wide range of versions available starting from series production
- Base housing concept for the entire modular system
- Easy integration into your system
- Short product launch times

Designed specifically for use
in commercial vehicles in rough
environments:

- City buses
- Trucks
- Mobile working machines such as:
Construction vehicles
Mining vehicles
- Agricultural vehicles such as:
Tractors
Various implements
Mowers

Technical data

	Maximum Operating voltage	Peak Power	Secondary DC voltage	Secondary DC current
DCU	848 VDC	(2x) 15/30/60 kW	–	–
DCU/PSU	848 VDC	15/30/60 kW	12/24 kW	200A
PSU	848 VDC	–	12/24 kW	200A
DCU S	800 VDC	11/22 kW	–	–



DCU

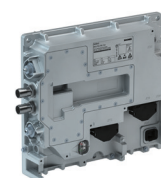

DCU/PSU

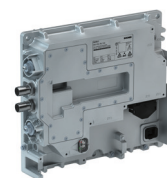

PSU



DCU S

Smart Solutions. Superior Support.®

[bucherhydraulics.com](https://www.bucherhydraulics.com)

Bucher Hydraulics AG
Industriestrasse 15
6345 Neuheim, Switzerland
T +41 41 757 03 33
info@bucherhydraulics.com