



OIL SOLUTIONS

## Master Module

Series ELMR...

PO Box 38  
Strathfieldsaye, VIC, 3551  
1800 OIL SOL  
1800 645 765

[sales@oilsolutions.com.au](mailto:sales@oilsolutions.com.au)

[www.oilsolutions.com.au](http://www.oilsolutions.com.au)

"For All Your Hydraulic Needs"









## Contents

Page

<b>1</b>	<b>Overview ELMR Module</b> .....	<b>5</b>
<b>2</b>	<b>Series ELMR 201 Slave Module</b> .....	<b>6</b>
	2.1 Description .....	6
	2.2 Technical data .....	6
	2.3 Output Characteristics .....	8
	2.4 Dimension .....	8
	2.5 Wiring .....	9
	2.6 Configuration examples .....	10
<b>3</b>	<b>Series ELMR 223 Master Module</b> .....	<b>11</b>
	3.1 Description .....	11
	3.2 Technical Data .....	11
	3.3 Dimensions .....	16
	3.4 Ordering Code .....	16
	3.5 Wiring .....	16
	3.6 CAN, RS232, ERROR, TEST .....	16
	3.7 Inputs / Outputs .....	17
<b>4</b>	<b>Series ELMR 225 Master Module</b> .....	<b>18</b>
	4.1 Description .....	18
	4.2 Technical Data .....	18
	4.3 Input Characteristics .....	20
	4.4 Output Characteristics .....	21
	4.5 Dimensions .....	22
	4.6 Ordering Code .....	22
	4.7 Accessories .....	23
	4.8 Wiring .....	23
	4.9 Installation .....	23
<b>5</b>	<b>Series ELMR 228 Master Module</b> .....	<b>25</b>
	5.1 Description .....	25
	5.2 Technical Data .....	25
	5.3 Input Characteristics .....	28
	5.4 Output Characteristics .....	29
	5.5 Dimensions .....	30
	5.6 Ordering Code .....	30
	5.7 Accessories .....	30
	5.8 Wiring .....	30
	5.9 Installation .....	31



## 1 Overview ELMR Module

<p>ELMR 201 Slave modul</p>	<p>Description</p>
	<p>Used as an expansion element in CAN bus systems            Closed screened metal housing            55-pin connector            10 ... 30 V DC            Status-LED: green, red</p> <p>8 outputs (digital, PWM, current-controlled)</p> <p>See chapter 2</p>
<p>ELMR 223 Master module</p>	<p>Description</p>
	<p>Used as an expansion element in CAN bus systems            Closed screened metal housing            55-pin connector            10 ... 32 V DC            Status-LED: red, green, blue</p> <p>8 outputs PWMi            4 outputs PWM, digital            8 outputs digital            4 H-bridges            8 inputs (digital analog, frequency)</p> <p>See chapter 3</p>
<p>ELSK 225 Master module</p>	<p>Description</p>
	<p>Used as an expansion element in CAN bus systems            Plastic housing black            10 ... 32 V DC            Status-LED: red, green, orange</p> <p>2 outputs (digital, PWMi)            10 outputs (digital, PWM)            4 inputs (digital analog, frequency)            4 inputs (digital, resistor)</p> <p>See chapter 4</p>
<p>ELMR 228 Master module</p>	<p>Description</p>
	<p>Used as an expansion element in CAN bus systems            Plastic housing black            8 ... 32 V DC            Status-LED: red, green, orange</p> <p>8 outputs (digital, PWMi)            4 inputs (digital, resistor)            4 inputs (digital analog, frequency)</p> <p>See chapter 5</p>

## 2 Series ELMR 201 Slave Module



- The extreme mechanical stresses that result from impacts and shock loadings
- Low a. high ambient temperature while in operation
- the direct effects of dirt, water and dampness during field service
- The large voltage fluctuations that are found in battery/ alternator systems
- Severe interference effects, whether radiated or conductorlinked, on the entire electrical system

### 2.1 Description

The ELMR201 slave module is used as an expansion element in Bucher CAN bus systems. The module has 8 outputs that are available with or without current compensation. The CANopen protocol is used to communicate with the Bucher master modules ELMR221 to ELMR224.

### 2.2 Technical data

#### 2.2.1 Test standards and regulations

Test standards and regulations	
Humidity test to IEC 68-2-30	≤ 90% rel. humidity, non-condensing
Mechanical resistance	Vibration to IEC 68-2-6 Shock to IEC 68-2-27 Bump to IEC 68-2-29
Immunity to conducted interference	DIN 40839 / part 1, pulses 1, 2, 3a, 3b (corresponds to ISO 7637) severity level 4, function state A
	DIN 40839 / part 1, pulses 5 (corresponds to ISO 7637) severity level 1, function state C
	DIN 40839 / part 3, pulses 1, 2, 3a, 3b (corresponds to ISO 7637) severity level 4, function state A
Immunity to interfering fields	Guideline 95/54/EG to EN 50082-2
Interference emission	Guideline 95/54/EG to EN 50081-1

#### 2.2.2 General Characteristics

General Characteristics	
Housing	Closed screened metal housing with flange fastening
Dimensions (l x w x h)	132 x 43 x 153 mm
Mounting	By means of 4 M5 x L screws to DIN 7500 or DIN 7984 mounting position horizontal or vertical to the mounting wall

General Characteristics	
Connection	55-pin connector, latched, protected against reverse polarity; type AMP housing or Framatome AMP junior timer contacts, crimp connentions 0,5 / 2,5 mm <sup>2</sup>
Output	8
Can be configured as	Digital, positive switching (High-Side) PWM channel Current-controlled channel
Switching current per output	Max. 4 A (without current monitoring) Max. 2 A (with current monitoring)
Total current	Max. 16 A

### 2.2.3 Electrical Characteristics

Electrical Characteristics			
Operating voltage $U_B$	10...30 V DC		
Current consumption	≤ 100 mA (without external load)		
Operating temperature	-40°C...+85°C		
Storage temperature	-40°C...+90°C		
Protection	IP 67 (protection for plugs, depending on cable processing)		
Interface	CAN interface 2.0 B, ISO 11898		
Baud rate	10 kBit/s ... 1 MBit/s (default 125 kBit/s)		
Communication profile	CANopen, CiA DS 301 version 3.0, CiA DS 401 version 1.4		
Node-ID	32 (Default)		
Status LED	Two-colour LED (red/green)		
Operating status (status-LED)	LED colour	Flashing frequency	Description
If both faults occur simultaneously, the LED appears orange.	Green	Constantly Off Constantly On 2,0 Hz	No operating Voltage CANopen: PRE-OPERATIONAL/ PREPARED CANopen: OPERATIONAL
	Red	Constantly On	Communication fault

### 2.3 Output Characteristics

Outputs	Technical Data
Digital outputs	8 semi-conductor outputs, short-circuit and overload protection Switching voltage 10...30 V DC Switching current max. 4 A (without current monitoring) max. 2 A (with current monitoring) Total current max. 16 A Current monitoring of 2 channels each can be selected by means of wire connection, the following channels are combined: 1+2, 3+4, 5+6, 7+8
PWM outputs	2 outputs each can be configured as PWM channel, the following channels are combined: 1+2, 3+4, 5+6, 7+8 PWM frequency 20...250 Hz Pulse break ratio 1...1000% Resolution 1% Load current max. 4 A Total current max. 16 A
Current outputs	2 outputs each can be configured as current channel, the following channels are combined: 1+2, 3+4, 5+6, 7+8 PWM frequency 20...250 Hz Control range 0,1...2 A Control resolution 2,5 mA Setting resolution 1 mA Precision $\pm 2\%$ FS Load current max. 2 A Min. load resistance $12\Omega$ (for $U_B = 24$ V DC)
Note	Digital and PWM / current output can be combined as a pair

### 2.4 Dimension

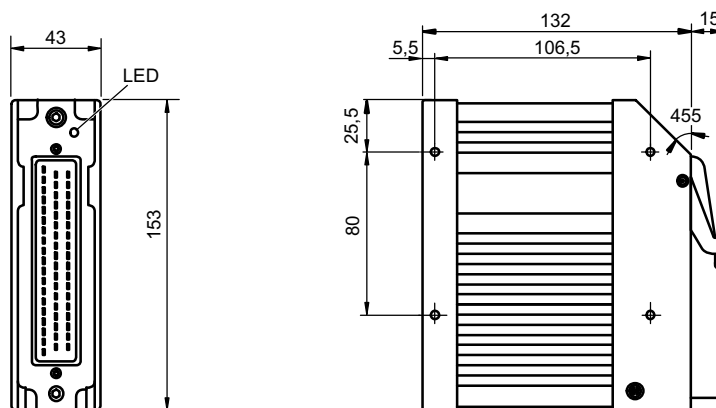

Description	Ordering code	Item No.
ELMR201-01*** CAN	Electronic	100030588

## 2.5 Wiring

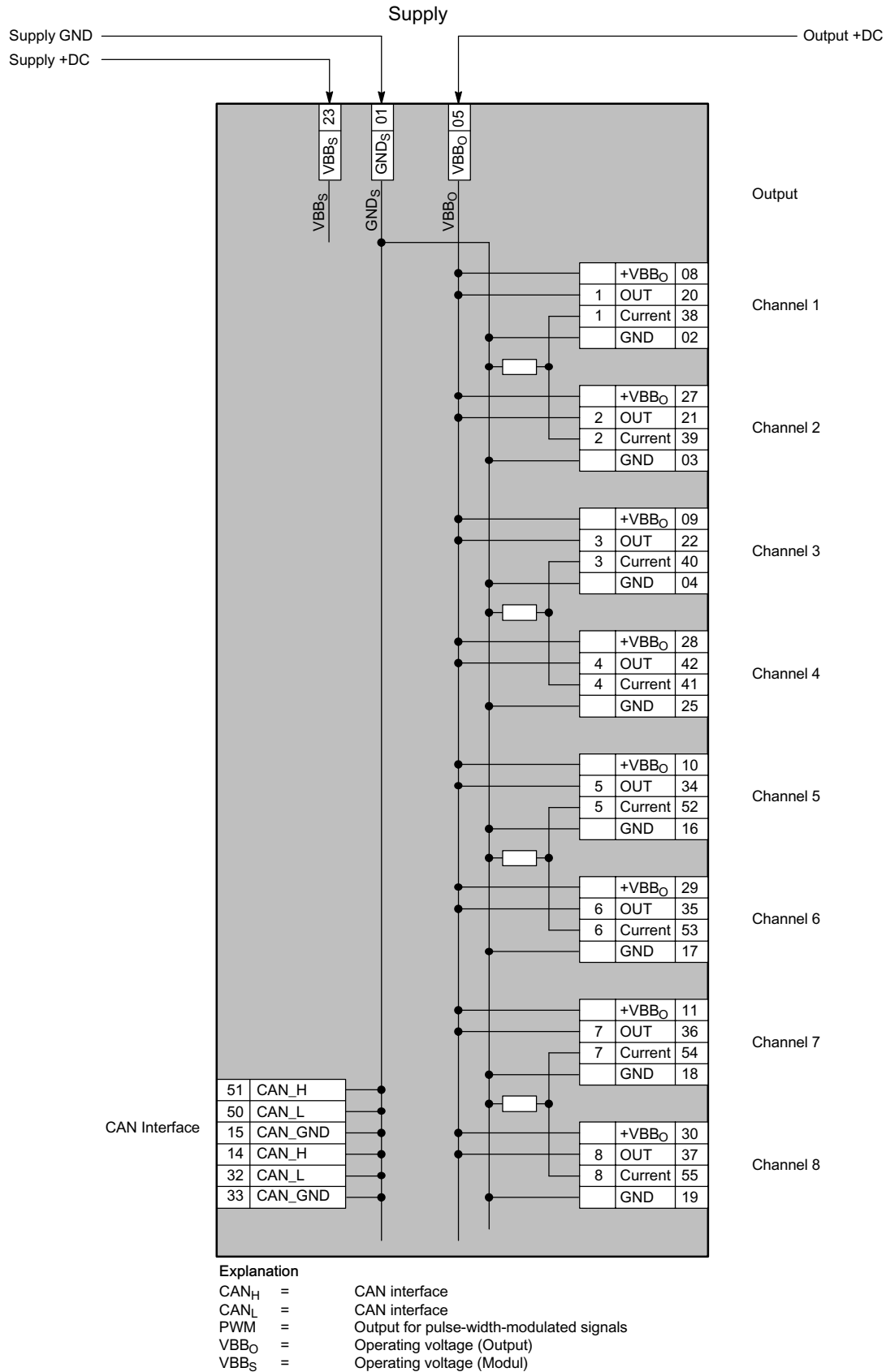

**IMPORTANT:** Before the voltage is applied please consider that the following pins must be connected to the respective potentials!

## 2.6 Configuration examples

### 2.6.1 Example 1

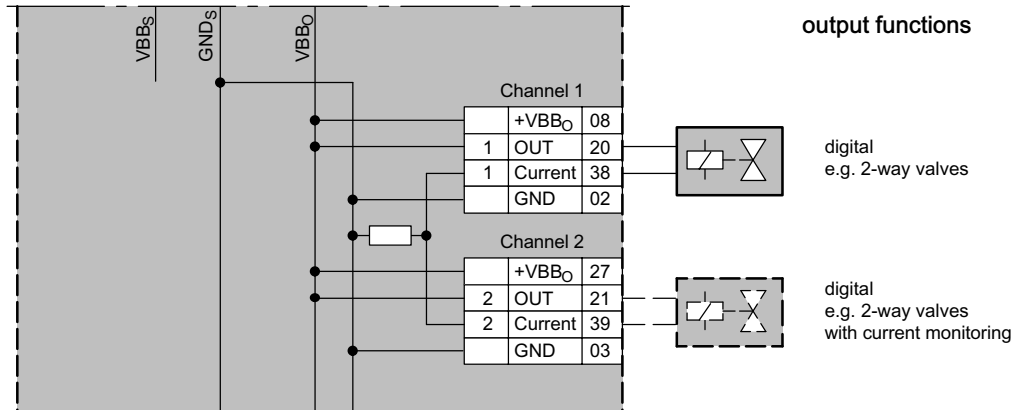

### 2.6.2 Example 2

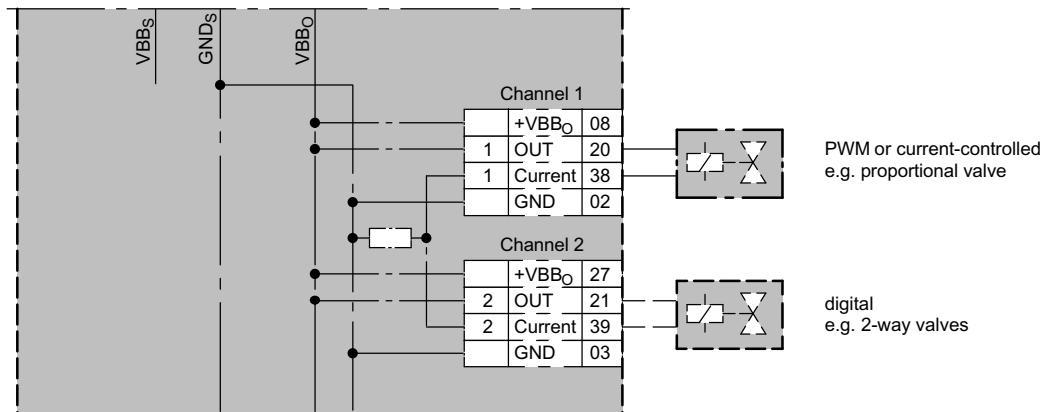

### 2.6.3 Example 3

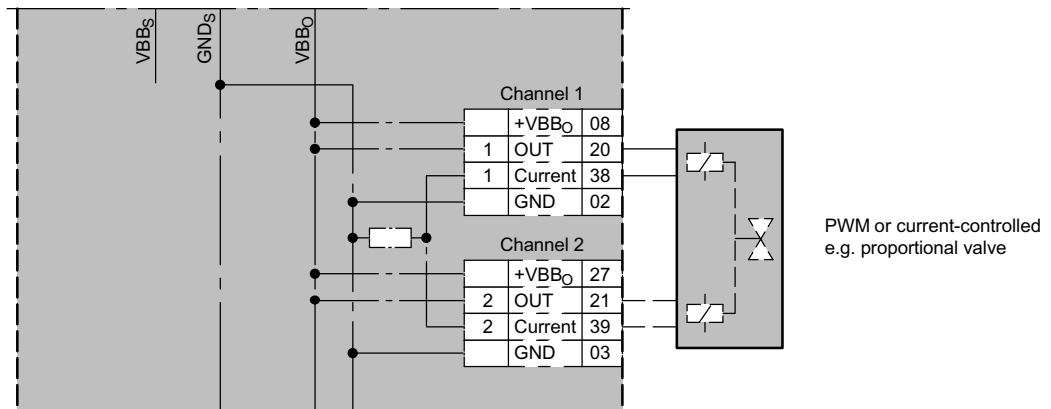

### 3 Series ELMR 223 Master Module

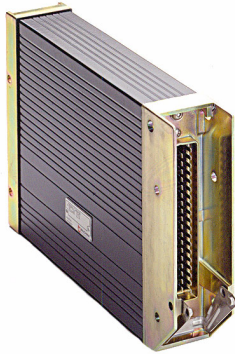

- Electrical data and equipment is optimised for use in the mobile industry
- Programming to IEC 61131-3
- Diagnostic functions for software and hardware
- Outputs are protected against short-circuits and overloads; can be examined by diagnostics
- RS232 serial interface
- CAN-Bus (master) with CANopen protocol
- Automatic, and program-controlled, data storage in flash EPROM

#### 3.1 Description

The ELMR223 master module is used as a controller in Bucher CAN bus systems. The module can have up to 24 power outputs, some of which are configurable. The features of the operating system, which was specially developed by Bucher Hydraulic, enable customer applications to be developed in significantly shorter timescales. The operating system represents the intelligence and functionality of

the complete electronic system. It includes interface communications, parameterisation, configuration, I/O processing, recording/data logging and parameter-driven control algorithms (e.g. for controlling synchronous motion). The operating system is in use in numerous applications and is therefore robust, and proven to a high degree.

##### 3.1.1 Application examples

- The extreme mechanical stresses that result from impacts and shock loadings
- Low and high ambient temperatures while in operation
- The direct effects of dirt, water and dampness during field service
- The large voltage fluctuations that are found in battery/alternator systems
- Severe interference effects, whether radiated or conductor-linked, on the entire electrical system

#### 3.2 Technical Data

##### 3.2.1 Test standards and regulations

Test standards and regulations	
Climatic tes	Damp heat to EN 60068-2-30, test Db ( $\leq 95\%$ rel. humidity, non-condensing) Salt mist test to EN 60068-2-52, test Kb, severity level 3 Degree of protection to EN 60529
Mechanical resistance	Vibration to IEC 68-2-6, Test Fc Shock to IEC 68-2-27, Test Ea Bump to EN 60068-2-29, Test Eb
Immunity to conducted interference	To ISO 7637-2, pulses 2, 3a, 3b, severity level 4, function state A
	to ISO 7637-2, pulses 5, severity level 1, function state A
	tp ISO 7637-2, pulses 1, severity level 4, function state C
Immunity to interfering fields	Directive 95/54/EG (at 100 V/m) and DIN EN 61326 (e1 type approval)
Interference emission	Directive 95/54/EG and DIN EN 61326 (e1 type approval)

### 3.2.2 General Characteristics

General characteristics	Description, value, unit
Housing	closed, screened metal housing with flange fastening
Dimensions (h x w x d)	153 x 225 x 43 mm
Mounting	by means of 4 M5 x L screws to DIN 7500 or DIN 7984 mounting position horizontal or vertical to thr mounting wall
Connection	55-pin connector, latched, protected against reverse polarity type AMP housing or Framatome AMP junior timer contacts, crimp connection 0,5 / 2,5 mm <sup>2</sup>
Weight	1,2 kg
Operating/ storage temperature	-40°C ... +85°C
Protection	IP 67 (protection rating for plug deo. on cable preparation)

### 3.2.3 Electrical Characteristics

Electrical characteristics	Description, value, unit	
Operating voltage $U_B$	10...32 V DC	
	Overvoltage	36 V for $t \leq 10$ s
	undervoltage detection	for $U_B \leq 9,5$ V
	Auto save	for $U_B \leq 9,0$ V
Current consumption	$\leq 160$ mA (without external load at 24 V DC)	
CAN interface 1	CAN interface 2.0 B, ISO 11898	
	Baud rate	20 Kbits/s ... 1 Mbit/s (default setting 125 Kbits/s)
	Communication profile	CANopen, CiA DS 301 version 4, CiA DS 401 version 1.4
Node-ID (CANopen)	Hex 20 (= dez 32)	
CAN interface 2	CAN interface 2.0 A/B, ISO 11898	
	Baud rate	20 Kbits/s ... 1 Mbit/s (default setting 125 Kbits/s)
	Communication profile	SAE J 1939 or free protocol
Serial interface	RS 232 C	
	Baud rate	9,6 kBit/s, 19,2 kBit/s, 28,8 kBit/s
	Topology	point-to-point (max. 2 participants); master-slave connect.
	Protocol	predefined ifm protocol (INTELHEX)
Processor	CMOS microcontroller 16 Bit C167CS; cycle frequency 20/40 MHz	
Device monitoring	undervoltage monitoring watchdog function check sum test for program and system excess temperature monitoring	
Process monitoring concept	two relays according to EN 954 monitor two groups of 12 outputs each	
Program memory	1 MByte Flash, can be used by the user	
Data memory	128 Kbytes SRAM, 32 Kbytes Flash, 3 Kbytes FRAM	

Electrical characteristics	Description, value, unit
Data memory (protected in case of power failure)	256 Byte (auto-save memory)
Status indication	3-colour LED (red/green/blue)

### 3.2.4 Configurations

Input/output channels (total)	max. 40 (the total number which is available depends on the wiring and configuration of the controller)				
Inputs	max. 40 (corr. to 0 outputs)				
		Number	Signal	Version	
	Possible configurations	8 or	Digital Analog	For positive sensor signals with diagnostic capability 0...10/32 V DC, 0/4...20 mA or ratiometric	B <sub>L</sub> A
		8	Digital	For positive sensor signals	B <sub>L</sub>
		4 or	Digital Frequency	For positive sensor signals, with diagnostic capability max. 50 kHz	B <sub>L</sub> I <sub>L</sub>
		4 or	Digital Frequency	For positive/negative sensor signals, with diagnostic capability max. 1 kHz	B <sub>L/H</sub> I <sub>L/H</sub>
		8	Digital	For positive/negative sensor signals, diagnosable	B <sub>L/H</sub>
8		Digital	For positive sensor signals, diagnosable	B <sub>L</sub>	
Outputs	Max. 24 (corr. to 16 inputs)				
		Number	Signal	Version	
	Possible configurations	8 or or	Digital PWM Current-controlled	Positive switching (High Side), diagnosable PWM frequency 20...250 Hz 0,1...4 A	B <sub>H</sub> PWM PWM <sub>I</sub>
		8	Digital	Positive switching (High Side), diagnosable	B <sub>H</sub>
		4 or	Digital PWM	Positive switching (High Side),diagnosable PWM frequency 20...250 kHz	B <sub>H</sub> PWM
4		Digital	Positive/negative switching (High/Low Side), with diagnostic capability can also be used as H bridge	B <sub>H/L</sub> H-Bridge	

Operating states (Status-LED)	LED-colour	Status	Description
If both faults occur simultaneously, the LED appears orange.		Off	No operating voltage
	Orange	1 x On	Initialisation or reset checks
	Green	5 Hz	No operating system loaded
	Green	0,5 Hz 2,0 Hz On	Run, CANopen: PREOPERATIONAL Run, CANopen: OPERATIONAL Stop, CANopen: PREPARED
	Red	0,5 Hz 2,0 Hz On	Run with error (CANopen: PREOPERATIONAL) Run with error (CANopen: OPERATIONAL) Fatal error or stop with error

### 3.2.5 Input Characteristics

Digital/analogue inputs (B<sub>L</sub>, A)

%IW00...07

%IX0.00...07

Can be configured as:

Characteristics	Description, value, unit	
Voltage inputs	Voltage input Resolution Input resistance Input frequency	0...10/32 V 10 bit <sub>s</sub> 50/30 kΩ 50 Hz
Current inputs	Current input Resolution Input resistance Input frequency	0/4...20 mA 10 bit 400 kΩ 50 Hz
Digital inputs for positive sensor signals, diagnosable	Switch-on level Switch-off level Input resistance Input frequency	0,7 U <sub>B</sub> 0,4 U <sub>B</sub> 30 kΩ 50 Hz
Digital inputs for positive sensor signals	Switch-on level Switch-off level Input resistance Input frequency	0,4...0,7 U <sub>B</sub> 0,29 U <sub>B</sub> 3,21 kΩ 50 Hz
Digital inputs for positive sensor signals, diagnosable	Switch-on level Switch-off level Input resistance Input frequency	0,7 U <sub>B</sub> 0,4 U <sub>B</sub> 2,86 kΩ 50 Hz
Frequency inputs for positive sensor signals, diagnosable. evaluation with integrated comparator	Input resistance Input frequency	2,86 kΩ max. 50 Hz
Digital inputs for positive/negative sensor signals, diagnosable	Switch-on level Switch-off level Input resistance Input frequency	0,7 U <sub>B</sub> 0,4 U <sub>B</sub> 3,21 kΩ 50 Hz
Frequency inputs for positive/negative sensor signals with diagnosable, evaluation with integrated comparator	Input resistance Input frequency	3,21 kΩ max. 1 kHz
Digital inputs for positive/negative sensor signals, diagnosable	Switch-on level Switch-off level Input resistance Input frequency	0,7 U <sub>B</sub> 0,4 U <sub>B</sub> 3,21 kΩ 50 Hz
Digital inputs for positive sensor signals, diagnosable	Switch-on level Switch-off level Input resistance Input frequency	0,4...0,7 U <sub>B</sub> 0,2...0,24 U <sub>B</sub> 3,21 kΩ 50 Hz
Test input	During the test mode (e.g. programming) the "TEST" connection must be connected to U <sub>B</sub> . For the "RUN" mode the Input must not be connected. Input resistance 3,21 kΩ	
*) NAMUR inputs	Digital inputs with diagnostic capability can be used as NAMUR inputs when used with an external resistor connection. Supply voltage 5...25 V; e.g. ifm NAMUR sensors NT5001...NN5002	

### 3.2.6 Output Characteristics

Characteristics	Description, value, unit
Outputs (B <sub>H</sub> , PWM, PWM <sub>I</sub> ) %QX0.00...07 Can be configured as:	Semiconductor outputs, with diagnostic capability posit. switching (high side), short-circuit an overload protected switching voltage 10...32 V DC switching current max. 4 A
%QX0.00...05 Can be configured as:	PWM outputs; with diagnostic capability PWM frequency max. 250 Hz PWM pulse ratio 1...99 % Resolution depending on PWM frequency Load current max. 4 A Integr. pull-down resistor (4,7 kΩ) to trigger Danfoss valves
	Current-controlled outputs; with diagnostic capability Switching current 0,1...4 A Total current max. 16 A Setting resolution 1 mA Control resolution 5 mA Accuracy ± 2% FS
Outputs (B <sub>H</sub> ) %QX0.08...15 Can be configured as:	Semiconductor outputs, with diagnostic capability positive switching (high side), short-circuit an overload protected Switching voltage 10...32 V DC Switching current max. 2 A Output frequency max. 100 Hz (depending on load)
Outputs (B <sub>H</sub> , PWM) %QX0.16, 19, 20, 23 Can be configured as:	Semiconductor outputs, with diagnostic capability positive switching (high side), short-circuit an overload protected Switching voltage 10...32 V DC Switching current max. 4 A Output frequency max. 100 Hz (depending on load)
	PWM outputs PWM frequency max. 250 Hz PWM pulse ratio 1...99 % Resolution depending on the PWM frequency Load current max. 4 A
Outputs (B <sub>L/H</sub> ) %QX0.17, 18, 21, 22 Can be configured as:	Semiconductor outputs, with diagnostic capability positive/negative switching (high/low side), short-circuit and overload protected Switching voltage 10...32 V DC Switching current max. 4 A Output frequency max. 100 Hz (depending on load)
Internal relay outputs for electrically isolated deactivation of the outputs	Normally open contacts in series to 2 groups of 12 semiconductor outputs. Sustained forcing by means of hardware and additional controlling by means of user program.
	The relays must always be switched without load!
	Total current max. 12 A je Gruppe Switching current 0,1...15 A Overload current 20 A Number of operating cycles ≤ 10 <sup>6</sup> (without load) Switching-time constant ≤ 3 ms

#### Explanation

A = Analog  
B<sub>H</sub> = Binary High Side  
B<sub>L</sub> = Binary Low Side  
I<sub>H</sub> = Pulse High Side  
I<sub>L</sub> = Pulse Low Side

PWM = Pulse width modulation  
PWM<sub>I</sub> = Current-controlled output  
%IWx = IEC-address for analogue input  
%IX0.xx = IEC-address for binary input  
%QX0.xx = IEC-address for binary output

### 3.3 Dimensions

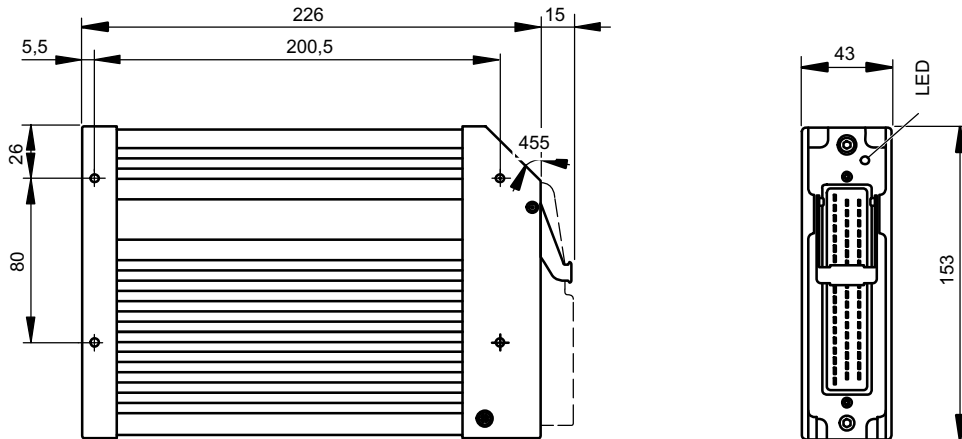

### 3.4 Ordering Code

Description	Ordering code	Item No.
ELMR223-***** CAN	CAN without software	100026514

### 3.5 Wiring

Pin	Potential	Description	Note
23	VBB <sub>S</sub> (10...32 V DC)	Supply sensors and module	
05	VBB <sub>O</sub> (10...32 V DC)	Supply outputs	
34	VBB <sub>R</sub> (10...32 V DC)	Supply via relay	relay awitched (1)
01	GND <sub>S</sub>	Ground sensors and module	relay awitched (2)
15	GND <sub>O</sub>	ground outputs	
12	GND <sub>A</sub>	ground analog outputs	

### 3.6 CAN, RS232, ERROR, TEST

Pin	Potential	Description	Note
14	CAN1 <sub>H</sub>	CAN-Interface 1 (High)	
32	CAN1 <sub>L</sub>	CAN-Interface 1 (Low)	
26	CAN2 <sub>H</sub>	CAN-Interface 2 (High)	SAE J 1939
25	CAN2 <sub>L</sub>	CAN-Interface 2 (Low)	SAE J 1939
33	GND	ground	
06	RxD	RS 232-Interface (programming)	Pin 03, PC D-Sub (9 pin)
07	TxD	RS 232-Interface (programming)	Pin 02, PC D-Sub (9 pin)
13	ERROR	Error output B <sub>H</sub>	
24	TEST	Test input	

### 3.7 Inputs / Outputs

Pin	Inputs	Configuration	Outputs	Configuration	diagnosable input / output	relay switched
08	%IX0.00 / %IW00	B <sub>L</sub> A	-	-	• / -	
27	%IX0.01 / %IW01	B <sub>L</sub> A	-	-	• / -	
09	%IX0.02 / %IW02	B <sub>L</sub> A	-	-	• / -	
28	%IX0.03 / %IW03	B <sub>L</sub> A	-	-	• / -	
10	%IX0.04 / %IW04	B <sub>L</sub> A	-	-	• / -	
29	%IX0.05 / %IW05	B <sub>L</sub> A	-	-	• / -	
11	%IX0.06 / %IW06	B <sub>L</sub> A	-	-	• / -	
30	%IX0.07 / %IW07	B <sub>L</sub> A	-	-	• / -	
44	%IX0.08	B <sub>L</sub>	%QX0.00	B <sub>H</sub> PWM PWM <sub>I</sub>	- / •	VBB <sub>O</sub> (1)
45	%IX0.09	B <sub>L</sub>	%QX0.01	B <sub>H</sub> PWM PWM <sub>I</sub>	- / •	VBB <sub>O</sub> (1)
46	%IX0.10	B <sub>L</sub>	%QX0.02	B <sub>H</sub> PWM PWM <sub>I</sub>	- / •	VBB <sub>O</sub> (1)
47	%IX0.11	B <sub>L</sub>	%QX0.03	B <sub>H</sub> PWM PWM <sub>I</sub>	- / •	VBB <sub>O</sub> (1)
20	%IX0.12	B <sub>L</sub> I <sub>L</sub>	-	-	• / -	
02	%IX0.13	B <sub>L</sub> I <sub>L</sub>	-	-	• / -	
21	%IX0.14	B <sub>L</sub> I <sub>L</sub>	-	-	• / -	
38	%IX0.15	B <sub>L</sub> I <sub>L</sub>	-	-	• / -	
36	%IX0.16	B <sub>L</sub>	%QX0.04	B <sub>H</sub> PWM PWM <sub>I</sub>	- / •	VBB <sub>R</sub> (2)
54	%IX0.17	B <sub>L</sub>	%QX0.05	B <sub>H</sub> PWM PWM <sub>I</sub>	- / •	VBB <sub>R</sub> (2)
17	%IX0.18	B <sub>L</sub>	%QX0.06	B <sub>H</sub> PWM PWM <sub>I</sub>	- / •	VBB <sub>R</sub> (2)
53	%IX0.19	B <sub>L</sub>	%QX0.07	B <sub>H</sub> PWM PWM <sub>I</sub>	- / •	VBB <sub>R</sub> (2)
19	%IX0.20	B <sub>L</sub> / I <sub>L</sub> /H	-	-	• / -	
55	%IX0.21	B <sub>L</sub> / I <sub>L</sub> /H	-	-	• / -	
18	%IX0.22	B <sub>L</sub> / I <sub>L</sub> /H	-	-	• / -	
37	%IX0.23	B <sub>L</sub> / I <sub>L</sub> /H	-	-	• / -	VBB <sub>O</sub> (1)
39	%IX0.24	B <sub>L</sub> /H	%QX0.08	B <sub>H</sub>	• □ •	VBB <sub>O</sub> (1)
03	%IX0.25	B <sub>L</sub> /H	%QX0.09	B <sub>H</sub>	□ •	VBB <sub>O</sub> (1)
40	%IX0.26	B <sub>L</sub> /H	%QX0.10	B <sub>H</sub>	□ •	VBB <sub>O</sub> (1)
22	%IX0.27	B <sub>L</sub> /H	%QX0.11	B <sub>H</sub>	□ •	VBB <sub>O</sub> (1)
41	%IX0.28	B <sub>L</sub> /H	%QX0.12	B <sub>H</sub>	□ •	VBB <sub>O</sub> (1)
42	%IX0.29	B <sub>L</sub> /H	%QX0.13	B <sub>H</sub>	□ •	VBB <sub>O</sub> (1)
43	%IX0.30	B <sub>L</sub> /H	%QX0.14	B <sub>H</sub>	□ •	VBB <sub>O</sub> (1)
04	%IX0.31	B <sub>L</sub> /H	%QX0.15	B <sub>H</sub>	□ •	VBB <sub>O</sub> (1)
48	%IX0.32	B <sub>L</sub>	%QX0.16	B <sub>H</sub> PWM	□ •	VBB <sub>R</sub> (2)
49	%IX0.33	B <sub>L</sub>	%QX0.17	B <sub>H</sub> /L H-Bridge	□ •	VBB <sub>R</sub> (2)
31	%IX0.34	B <sub>L</sub>	%QX0.18	B <sub>H</sub> /L H-Bridge	□ •	VBB <sub>R</sub> (2)
50	%IX0.35	B <sub>L</sub>	%QX0.19	B <sub>H</sub> PWM	□ •	VBB <sub>R</sub> (2)
51	%IX0.36	B <sub>L</sub>	%QX0.20	B <sub>H</sub> PWM	□ •	VBB <sub>R</sub> (2)
52	%IX0.37	B <sub>L</sub>	%QX0.21	B <sub>H</sub> /L H-Bridge	□ •	VBB <sub>R</sub> (2)
16	%IX0.38	B <sub>L</sub>	%QX0.22	B <sub>H</sub> /L H-Bridge	□ •	VBB <sub>R</sub> (2)
35	%IX0.39	B <sub>L</sub>	%QX0.23	B <sub>H</sub> PWM	□ •	VBB <sub>R</sub> (2)

Note the double pin connection of inputs/outputs.

## 4 Series ELMR 225 Master Module



- Electrical data and equipment is optimised for use in the mobile industry
- Programming to IEC 61131-3
- Detection of under- and over-voltages
- Diagnostic functions for software and hardware
- Outputs are protected against short-circuits and overloads; can be examined by diagnostics
- CAN-Bus (master) with CANopen protocol
- Automatic data storage

### 4.1 Description

The ELMR225 master module is used as a controller in Bucher CAN bus systems. The module can have up to 12 power outputs, some of which are configurable. The features of the operating system, which was specially developed by Bucher Hydraulic, enable customer applications to be developed in significantly shorter timescales. The operating system represents the intelligence and functionality of

the complete electronic system. It includes interface communications, parameterisation, configuration, I/O processing, recording/data logging and parameter-driven control algorithms (e.g. for controlling synchronous motion). The operating system is in use in numerous applications and is therefore robust, and proven to a high degree.

#### 4.1.1 Application examples

- The extreme mechanical stresses that result from impacts and shock loadings
- Low and high ambient temperatures while in operation
- Severe interference effects, whether radiated or conductor-linked, on the entire electrical system

### 4.2 Technical Data

#### 4.2.1 Test standards and regulations

Test standards and regulations	Description
CE marking	EN 61000-6-2 Elektromagnetic compatibility (EMC) Noise immunity
	EN 61000-6-4 Elektromagnetic compatibility (EMC) Emission standard
	EN 61010-1 Safety requirements for electrical equipment for measurement, control and laboratory use
E1 marking	UN/ECE-R10 Emission standard Immunity with 100 V/m
Electrical tests	ISO 7637-2 Pulse 1, severity level: IV, function state C Pulse 2a, severity level: IV, function state A Pulse 2b, severity level: IV, function state C Pulse 3a, severity level: IV, function state A Pulse 3b, severity level: IV, function state A Pulse 4, severity level: IV function state A Pulse 5, severity level: III, function state C (data valid for the 24 V system) Pulse 4, severity level: III, function state C (data valid for the 12 V system)

Test standards and regulations	Description	
Climatic tests	EN 60068-2-30	Damp heat, cyclic Upper temperature 55 °C, number of cycles: 6
	EN 60068-2-78	Damp heat, steady state test temperature 40 °C / 93 % RH, test duration: 21 days
	EN 60068-2-52	Salt spray test Severity level 3 (motor vehicle) only with installed EC0401 or EC0402 cover
Mechanical tests	ISO 16750-3	Test VII: vibration, random Mounting location: vehicle body
	EN 60068-2-6	Vibration, sinusoidal 10 ... 500 Hz, 0,72 mm/10 g; 10 cycles/axis
	ISO 16750-3	Bumps 30 g/6 ms; 24.000 shocks
Tests for railway applications	EN 50121-3-2	Electromagnetic compatibility (EMC)
	EN 50155 clause 12.2	Electronic equipment used on rolling stock

#### 4.2.2 General Characteristics

General characteristics	Unit	Description, value
Housing		Plastic housing (black)
Dimensions (h x w x d) without cover	mm	163 x 112 x 25,5
Dimensions (h x w x d) with cover		163 x 112 x 68
Mounting		by means of 4 M4 x L screws to DIN 912 or DIN 7984 Mounting position horizontal or vertical to the mounting wall
Connection		AMP blade male terminals 6,3 mm, to be clipped into place and thus vibration-resistant, protected against reverse polarity, contacts AMP timer, CuZn pre- tinned, core cross-section 0,5 ... 2,5 mm <sup>2</sup>
Weight	kg	0,3
Operating/ storage temperature	°C	-40 ... +85
Protection		IP 54 (protection rating for plug deo. on cable prepar- ation)

#### 4.2.3 Electrical Characteristics

Electrical characteristics	Unit	Description, value
Operating voltage	V DC	8...32
Current consumption	mA	45 (at 24 V DC)
Overvoltage	V	36 V for $t \leq 10$ s
Undervoltage detection		at $U_B \leq 7,8$ V
Undervoltage shutdown		at $U_B \leq 7,0$ V
Processor		Freescle PowerPC, 50 MHz
Memory (total)		592 kByte RAM / 1536 kByte Flash / 1 kByte FRAM
Device monitoring		Undervoltage monitoring Watchdog function Checksum test for program and system Excess temperature monitoring

### 4.2.4 Configuration

Input/output channels (total)	Number	Version	
<b>Inputs</b>		<b>12 (configurable)</b>	
Configurations	4	Digital for positive / negative sensor signals Analogue (0...10 / 32 V DC, 0...20 mA, ratiometric) Frequency ( $\leq 30$ kHz)	B <sub>L</sub> /B <sub>H</sub> A FRQ
	4	Digital for positive sensor signals resistance measurement (0,016 ... 3,6 k $\Omega$ )	B <sub>L</sub>
	4	Digital for positive sensor signals	B <sub>L</sub>
<b>Outputs</b>		<b>12 (configurable)</b>	
Configurations	2	Positive switching (high Side), PWM output (20...250 Hz), 2A Current-controlled 0,02 ... 2 A, diagnosis	B <sub>H</sub> PWM PWM-I
	4	Positive switching (high side), PWM output (20...250 Hz) 2A, diagnosis	B <sub>H</sub> PWM
	4	Positive switching (high side), PWM frequency 20...250 kHz 1 A	B <sub>H</sub> PWM
	2	Positive switching (high side), PWM output (20...250 Hz), 4A, diagnosis	B <sub>H</sub> PWM

Operating states (status LED)	Colour	Blinking frequency	Description
If both faults occur simultaneously, the LED appears orange.	-	Permanently Off	No operating voltage
	Orange	1x On	Initialisierung or reset checks
	Green	5 Hz 2 Hz Permanently On	No operating system loaded application is running (RUN) application stopped (STOP)
	Red	10 Hz 5 Hz Permanently On	Application stopped (STOP with error) application stopped due to undervoltage system fault (FATAL ERROR))

## 4.3 Input Characteristics

Analogue-Inputs (A)

Connection A: 02, 03, 06, 07

IN0 ... IN3

Can be configured as:

Inputs	Technical data
Input voltage	Input voltage 0...10/32 V Resolution 10 bits Input resistance 65,6 / 50,7 k $\Omega$ Input frequency $\leq 500$ Hz
Current inputs, with diagnostic capability	Input current 0...20 mA Resolution 12 bits Input resistance 400 k $\Omega$ Input frequency $\leq 500$ Hz At a current of > 23 mA the input is switched to the voltage input!
Voltage inputs, 0...32 V, ratiometric	Function $(U_{IN} / U_B) \times 1000$ ‰ Value range 0...1000 ‰ Input resistance 50,7 k $\Omega$

Inputs	Technical data	
Binary voltage inputs for positive sensor signals	Switch-on level	> 0,7 U <sub>B</sub>
	Switch-off level	< 0,3 U <sub>B</sub>
	Input resistance	3,2 kΩ
	Input frequency	50 Hz
	Diagnosis wire break	> 0,95 U <sub>B</sub>
	Diagnosis short circuit	< 1 V
Binary voltage inputs vor negative sensor signals	Switch-on level	> 0,7 U <sub>B</sub>
	Switch-off level	< 0,3 U <sub>B</sub>
	Input resistance	3,2 kΩ
	Input frequency	50 Hz
Frequency inputs	Input resistance	3,2 kΩ
	Input frequency	≤ 30 kHz
	Switch-on level	> 0,35...0,48 U <sub>B</sub>
	Switch-off level	< 10,29 U <sub>B</sub>
Binary voltage inputs for positive sensor signals	Switch-on level	> 0,7 U <sub>B</sub>
	Switch-off level	< 0,3 U <sub>B</sub>
	Input resistance	3,2 kΩ
	Input frequency	50 Hz
	Diagnosis wire break	> 0,95 U <sub>B</sub>
	Diagnosis short circuit	< 1 V
Resistor input	<b>Resistor input</b>	
	Measuring range	0,016...3,6 kΩ
	Accuracy	± 3%
Binary voltage inputs for positive sensor signals	Switch-on level	> 0,7 U <sub>B</sub>
	Switch-off level	< 0,3 U <sub>B</sub>
	Input resistance	3,2 kΩ
	Input frequency	50 Hz
	Diagnosis wire break	> 0,95 U <sub>B</sub>
	Diagnosis short circuit	< 1 V

#### 4.4 Output Characteristics

Digital outputs (B<sub>H</sub>, PWM, PWM-I)

Connection D: 01, 03

OUT0 ... OUT1

Can be configurated as:

Outputs	Technical data	
Semiconductor outputs, positive switching (high side), short circuit and overload protected, with diagnostic capability	Switching voltage	8... 32 V DC
	Switching current	≤ 2 A
	Load resistance	≥ 6 Ω (at 12 V DC) ≥ 12 Ω (at 24 V DC)
PWM outputs	Output frequency	20...250 Hz
	Pulse / pause ratio	1... 1000 ‰
	Switching current	≤ 2 A
Current-controlled output	Output frequency	20...250 Hz
	Control range	0,02...2 A
	Setting resolution	1 mA
	Control resolution	2 mA
	If only one output is active, the switching current is ≤ 2,5 A max. Switch-on current	≤ 11 A
Semiconductor outputs, positive switching (high side), short-circuit and overload protected, with diagnostic capability, pull-up resistor disconnectable	Switching voltage	8 ... 32 V DC
	Switching current	≤ 2 A

Outputs	Technical data	
PWM outputs	Output frequency	20...250 Hz
	Pulse / pause ratio	1...1000 ‰
	Switching current	≤ 2 A
	If only one output is active, the switching current is ≤ 2,5 A	
	Max. switch-on	≤ 11 A
Semiconductor outputs, positive switching (high side), short-circuit and overload protected	Switching voltage	8...32 V DC
	Switching current	≤ 1 A
PWM outputs	Output frequency	20...250 Hz
	Pulse / pause ratio	1...1000 ‰
	Switching current	≤ 1 A
	Max. switch-on current	≤ 11 A
Semiconductor outputs, positive switching (high side), short circuit and overload protected with diagnostic capability, pull-up resistor disconnectable	Switching voltage	8...32 V DC
	Switching current	≤ 4 A
PWM outputs	Output frequency	20...250 Hz
	Pulse / pause ratio	1...1000 ‰
	Switching current	≤ 4 A
	Max. switch-on current	≤ 30 A
Free wheel diodes	Free wheel diodes for the deactivation of inductive loads are integrated	
Overload protection (valid for all outputs)	≤ 5 minutes (at 100% overload)	
Short-circuit strength (valid for all inputs and outputs)	≤ 5 minutes (contact + VBB with GND)	
Max. total current of the output supplies VBB <sub>1</sub> / VBB <sub>2</sub> (continuous current load)	Permanently ≤ 50 % of the nominal current	

#### 4.4.1 Explanation

A	= Analog	PWM	= Pulse width modulation
B <sub>H</sub>	= Binary high side	PWM <sub>I</sub>	= Current-controlled output
B <sub>L</sub>	= Binäre low side	VBB <sub>S</sub>	= Supply sensors / module
FRQ	= Frequency-/ pulse input	VBB <sub>1</sub>	= Supply OUT 0 ... 7
		VBB <sub>2</sub>	= Supply OUT8 ... 11

#### 4.5 Dimensions

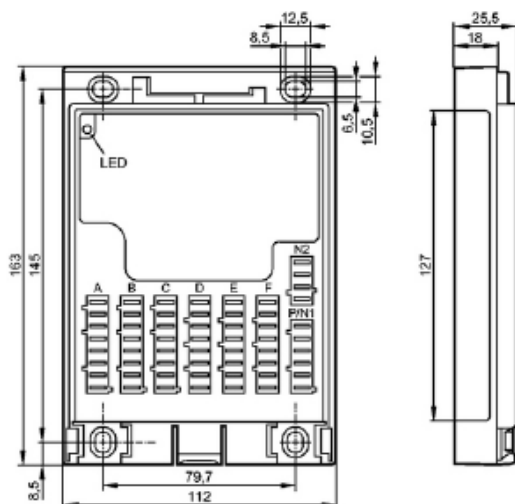

#### 4.6 Ordering Code

Model	Description	Item No.
ELMR225-****	CAN without software	100035806

## 4.7 Accessories

Model	Description	Item No.
ELMR225 Cover	Cover EC401 with cable seal	100036337

## 4.8 Wiring

A	B	C	D	E	F	N2	P/N1
8 poles						4 poles	6 poles
VBB	VBB <sub>S</sub>	VBB <sub>S</sub>	OUT0	OUT4	OUT8	VBB <sub>S</sub>	VBB <sub>S</sub>
IN0	IN4	IN8	GND	GND	GND	GND	VBB <sub>1</sub>
IN1	IN5	IN9	OUT1	OUT5	OUT9	CAN2_H	VBB <sub>2</sub>
GND	GND	GND	GND	GND	GND	CAN2_L	GND
GND	GND	GND	OUT2	OUT6	OUT10		CAN1_H
IN2	IN6	IN10	GND	GND	GND		CAN1_L
IN3	IN7	IN11	OUT3	OUT7	OUT11		
VBB <sub>S</sub>	VBB <sub>S</sub>	VBB <sub>S</sub>	GND	GND	GND		

## 4.9 Installation

### 4.9.1 Installation of the cable seal

- Insert the cable seal into the locator from below.  
The locking of the cable seal audibly clips into place.
- Cable seal is included in the in the cover 100036337.

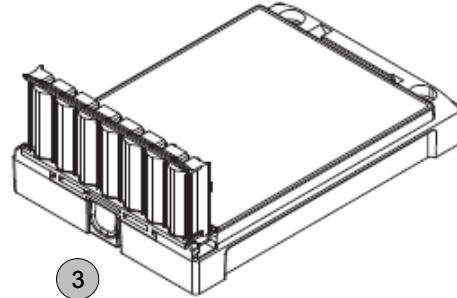
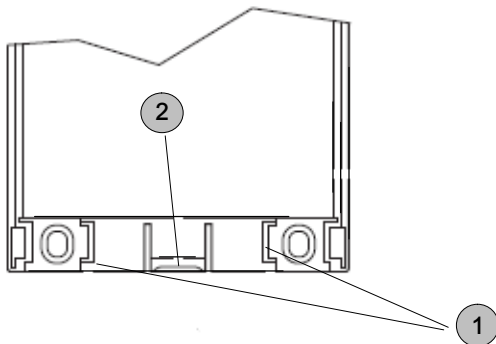

1	Locator for cable seal
2	Locking
3	Mounted cable seal

**IMPORTANT:** The cable seal cannot be used as strain relief of the cables.

### 4.9.2 Installation of the cover

The cover features a single-lever locking. Installation is done without tools.

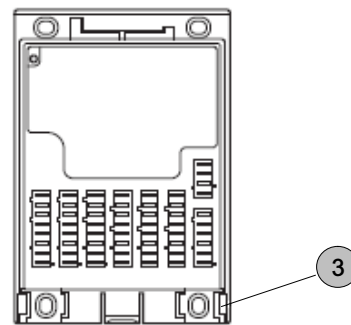
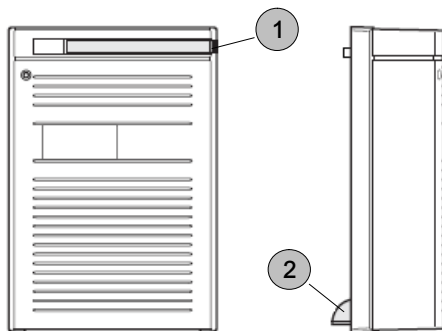

1	Locking lever
---	---------------

2	Cover guides
---	--------------

3	Insertion slots for cover guides
---	----------------------------------

1. Pull out the locking lever and rotate it towards you.
2. Place the cover diagonally onto the device. Insert the 2 cover guides, found at the bottom of the cover, into the slots.

3. Close the cover onto the lower part. The 2 guides and slots provide a pivot point.
4. Move the locking lever back into its initial position. -> The cover is locked.

## 5 Series ELMR 228 Master Module



- Electrical data and equipment is optimised for use in the mobile industry
- Programming to IEC 61131-3
- Detection of under- and over-voltages
- Diagnostic functions for software and hardware
- Outputs are protected against short-circuits and overloads; can be examined by diagnostics
- CAN-Bus (master) with CANopen protocol
- Automatic data storage

### 5.1 Description

The ELMR228 master module is used as a controller in Bucher CAN bus systems. The module can have up to 8 power outputs, some of which are configurable. The features of the operating system, which was specially developed by Bucher Hydraulic, enable customer applications to be developed in significantly shorter timescales. The operating system represents the intelligence and functionality of

the complete electronic system. It includes interface communications, parameterisation, configuration, I/O processing, recording/data logging and parameter-driven control algorithms (e.g. for controlling synchronous motion). The operating system is in use in numerous applications and is therefore robust, and proven to a high degree.

#### 5.1.1 Application examples

- The extreme mechanical stresses that result from impacts and shock loadings
- Low and high ambient temperatures while in operation
- Severe interference effects, whether radiated or conductor-linked, on the entire electrical system

### 5.2 Technical Data

#### 5.2.1 Test standards and regulations

Test standards and regulations		
CE marking	EN 61000-6-2: 2005	Elektromagnetic compatibility (EMC) Noise immunity
	EN 61000-6-4: 2007	Elektromagnetic compatibility (EMC) Emission standard
E1 marking	UN/ECE-R10	Emission standard Immunity with 100 V/m
Electrical tests	ISO 7637-2: 2004	Pulse 1, severity level: IV, function state C Pulse 2a, severity level: IV, function state A Pulse 2b, severity level: IV, function state C Pulse 3a, severity level: IV, function state A Pulse 3b, severity level: IV, function state A Pulse 4, severity level: IV function state A Pulse 5, severity level: III, function state C (data valid for the 24 V system) Pulse 4, severity level: III, function state C (data valid for the 12 V system)

Test standards and regulations		
Climatic tests	EN 60068-2-30	Damp heat, cyclic Upper temperature 55 °C, number of cycles: 6
	EN 60068-2-78: 2002	Damp heat, steady state test temperature 40 °C / 93 % RH, test duration: 21 days
	EN 60068-2-52: 1996	Salt spray test Severity level 3 (motor vehicle) only with installed EC0401 or EC0402 cover
Mechanical tests	ISO 16750-3: 2012	Test VII: vibration, random Mounting location: vehicle body
	EN 60068-2-6: 2008	Vibration, sinusoidal 10 ... 500 Hz, 0,72 mm/10 g; 10 cycles/axis
	ISO 16750-3: 2012	Bumps 30 g/6 ms; 24.000 shocks
Tests for railway applications	EN 50121-3-2: 2006	Electromagnetic compatibility (EMC)
	EN 50155 clause 12.2: 2008	Electronic equipment used on rolling stock

### 5.2.2 General Characteristics

General characteristics	Unit	Description, value
Housing		Plastic housing (black)
Dimensions (h x w x d) without cover	mm	163 x 112 x 25,5
Dimensions (h x w x d) with cover		163 x 112 x 68
Dimensions (h x w x d) with cover and basic display		163 x 112 x 73,4
Mounting		By means of 4 M4 x L screws to DIN 912 or DIN 7984
Mounting position		Mounting position horizontal or vertical to the mounting wall
Connection		AMP blade male terminals 6,3 mm, to be clipped into place and thus vibration-resistant, protected against reverse polarity Contacts AMP timer, CuZn pre-tinned, Core cross-section 0,5 ... 2,5 mm <sup>2</sup>
Weight	kg	0,3
Operating/ storage temperature	°C	-40 ... +85
Protection		IP 54 (protection rating for plug deo. on cable preparation)

### 5.2.3 Electrical Characteristics

Electrical characteristics	Unit	Description, value
Operating voltage	V DC	8 ... 32
Current consumption	mA	45 (at 24 V DC)
Overvoltage	V	36 V for $t \leq 10$ s
Undervoltage detection		At $U_B \leq 7,8$ V
Undervoltage shutdown		At $U_B \leq 7,0$ V

Electrical characteristics	Unit	Description, value
Processor	MHz	50 MHz
Memory (total)		592 kByte RAM / 1536 kByte Flash / 1 kByte FRAM
Device monitoring		Undervoltage monitoring Watchdog function Checksum test for program and system Excess temperature monitoring

#### 5.2.4 Configurations

Input/output channels (total)	Number	Version	
<b>Inputs</b>			
<b>8 (configurable)</b>			
Configurations	4	Digital for positive / negative sensor signals Analogue (0...10 / 32 V DC, 0...20 mA, ratiometric) Frequency ( $\leq 30$ kHz)	B <sub>L</sub> /B <sub>H</sub> A FRQ
	4	Digital for positive sensor signals Resistance measurement (0,016...3,6 k $\Omega$ )	B <sub>L</sub>
<b>Outputs</b>			
<b>8 (configurable)</b>			
Configurations	4	Positive switchig (high Side), PWM output (20...250 Hz), 2A Current-controlled 0,02...2 A, diagnosable	B <sub>H</sub> PWM PWM-I
	4	Positive switching (High Side), negative switching (Low-Side), 4 A PWM output (20 ... 250 Hz) 4A, diagnosable Current-controlled 0,2 ... 4 A, diagnostic H-bridge circuit	B <sub>H</sub> B <sub>L</sub> PWM PWM-I H-Bridge

Operating states (ststus LED)	Colour	Blinking frequency	Description
If both faults occur simultaneously, the LED appears orange.	-	Permanently Off	No operating voltage
	Orange	1x On	Initialisierung or reset checks
	Green	5 Hz 2 Hz Permanently On	No operating system loaded Application is running (RUN) Application stopped (STOP)
	Red	10 Hz 5 Hz Permanently On	Application stopped (STOP with error) Application stopped due to undervoltage System fault (FATAL ERROR)

### 5.3 Input Characteristics

Analog inputs (A, B<sub>L</sub>, B<sub>H</sub>, FRQ)

Connection A: 02, 03, 06, 07

IN0 ... IN3

Can be configured as:

Inputs	Technical data	
Input voltage	Input voltage Resolution Input resistance input frequency	0...10/32 V 10 bits 65,6 / 50,7 kΩ ≤ 500 Hz
Current inputs, with diagnostic capability	Input current Resolution Input resistance Input frequency At a current of > 23 mA the input is switched to the voltage input!	0 ... 20 mA 12 bits 400 kΩ ≤ 500 Hz
Input voltages, 0...32 V, ratiometric	Function Value range Input resistance	$(U_{IN} / U_B) \times 1000 \text{ }^0/_{00}$ 0 ... 1000 $^0/_{00}$ 50,7 kΩ
Binary voltage inputs for positive sensor signals	Switch-on level Switch-off level Input resistance Input frequency Diagnosis wire break Diagnosis short circuit	> 0,7 U <sub>B</sub> < 0,3 U <sub>B</sub> 3,2 kΩ 50 Hz > 0,95 U <sub>B</sub> < 1 V
Binary voltage inputs vor negative sensor signals	Switch-on level Switch-off level Input resistance Input frequency	> 0,7 U <sub>B</sub> < 0,3 U <sub>B</sub> 3,2 kΩ 50 Hz
Inputs frequency	Input resistance Input frequency Switch-on level Switch-off level	3,2 kΩ ≤ 30 kHz > 0,35 ... 0,48 U <sub>B</sub> < 10,29 U <sub>B</sub>

Digital- /resistor inputs (B<sub>L</sub>, R)

Connection B: 02, 03, 06, 07

IN4 ... IN7

Can be configured as:

Inputs	Technical data	
Binary voltage inputs for positive sensor signals	Switch-on level Switch-off level Input resistance Input frequency Diagnosis wire break Diagnosis short circuit	> 0,7 U <sub>B</sub> < 0,3 U <sub>B</sub> 3,2 kΩ 50 Hz > 0,95 U <sub>B</sub> < 1 V
Resistor input	Measuring current Input frequency Measuring range Accuracy Diagnosis Diagnosis short circuit against VBB	< 2,0 mA 50 Hz 0,016... 3,6 kΩ ± 2% FS: 16 Ω...3 kΩ ± 5% FS: 3 Ω...15 kΩ ± 10% FS: 15 kΩ...15 kΩ > 31 kΩ

## 5.4 Output Characteristics

Digital outputs (B<sub>H</sub>, PWM, PWM<sub>I</sub>)

Connection D: 01, 03, 05, 07

OUT0 ... OUT3

Can be configured as:

Outputs	Technical data	
Semiconductor outputs, positive switching (high side), short circuit and overload protected	Switching voltage	8...32 V DC
	Switching current	≤ 2 A
	Load resistance	≥ 6 Ω (at 12 V DC) ≥ 12 Ω (at 24 V DC)
PWM outputs	Output frequency	20...250 Hz
	Pulse / pause ratio	1...1000 <sup>0/00</sup>
	Switching current	≤ 2 A
Current-controlled output	Output frequency	20...250 Hz
	Control range	0,02 2 A
	Setting resolution	1 mA
	Control resolution	2 mA

Maximum ambient temperature by PWM operation ≤ 70° C.

Digital outputs (B<sub>H</sub>, PWM, PWM<sub>I</sub>)

Connection D: 01, 03, 05, 07

OUT0 ... OUT3

Can be configured as:

Outputs	Technical data	
Semiconductor outputs, positive switching (high side), short-circuit and overload protected, diagnosable, PullUp resistor disconnected	Switching voltage	8...32 V DC
	Switching current	≤ 2 A
	Max. energy recovery	< 3 J (bei 25°C)
	Load resistor	> 3 Ω (bei 12 V DC) > 6 Ω (bei 24 V DC)
PWM-output	Output frequency	20...250 Hz
	Pulse / pause ratio	1...1000 <sup>0/00</sup>
	Switching current	≤ 2 A
Currentcontrolled output	Output frequency	20...250 Hz
	Control range	0,02...4 A
	Control resolution	2 mA
Free wheel diodes	Free wheel diodes for the deactivation of inductive loads are integrated	
Overload protection (valid for all outputs)	≤ 5 minutes (at 100% overload)	
Short-circuit strength (valid for all inputs and outputs)	≤ 5 minutes (contact + VBB with GND)	
Max. Total current of the output supplies VBB <sub>1</sub> / VBB <sub>2</sub> (continuous current load)	permanently ≤ 50 % of the nominal current	

Maximum ambient temperature by PWM operation ≤ 70° C.

### 5.4.1 Explanations

A = Analog  
 B<sub>H</sub> = Binary high side  
 B<sub>L</sub> = Binäry low side  
 FRQ = Frequency-/ pulse input  
 H = H-bridges function

PWM = Pulse width modulation  
 PWM-I = Current-controlled output  
 R = Resistance input  
 VBB<sub>S</sub> = Supply sensors / module  
 VBB<sub>1</sub> = Supply OUT0 ... 3  
 VBB<sub>2</sub> = Supply OUT4 ... 7

## 5.5 Dimensions

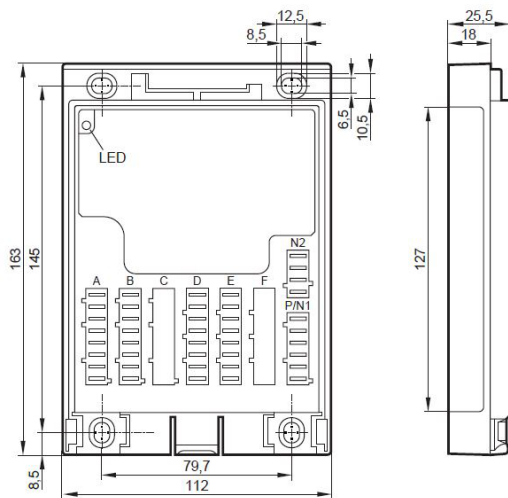

## 5.6 Ordering Code

Model	Description	Part number
ELMR 228-****	CAN without software	100036680

## 5.7 Accessories

Model	Description	Part number
ELMR225-cover	Cover EC401 with cable seal	100036337

## 5.8 Wiring

A	B	C	D	E	F	N2	P/N1
8-polig						4-polig	6-polig
VBB <sub>S</sub>	VBB <sub>S</sub>		OUT0	OUT4		VBB <sub>S</sub>	VBB <sub>S</sub>
IN0	IN4		GND	GND		GND	VBB <sub>1</sub>
IN1	IN5		OUT1	OUT5		CAN2_H	VBB <sub>2</sub>
GND	GND		GND	GND		CAN2_L	GND
GND	GND		OUT2	OUT6			CAN1_H
IN2	IN6		GND	GND			CAN1_L
IN3	IN7		OUT3	OUT7	OUT11		
VBB <sub>S</sub>	VBB <sub>S</sub>		GND	GND	GND		

### 5.8.1 Explanations

VBB1 = supply OUT 0 ... 3

VBB2 = supply OUT 4 ... 7

## 5.9 Installation

### 5.9.1 Installation of the cable seal

- Cable seal is included in the in the cover 100036337.
- Insert the cable seal into the locator from below.  
The locking of the cable seal audibly clips into place.

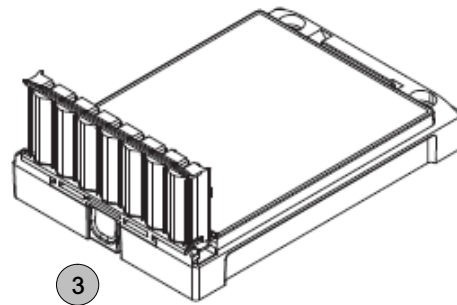
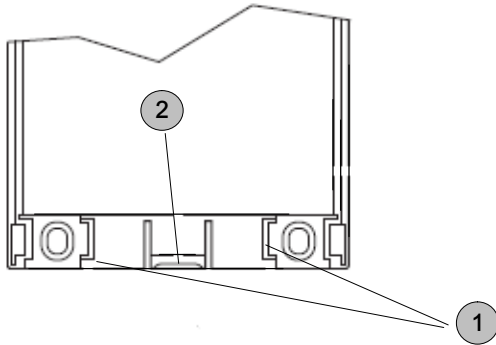

1	Locator for cable seal
2	Locking
3	Mounted cable seal

**IMPORTANT:** The cable seal cannot be used as strain relief of the cables.

### 5.9.2 Installation of the cover

The cover features a single-lever locking. Installation is done without tools.

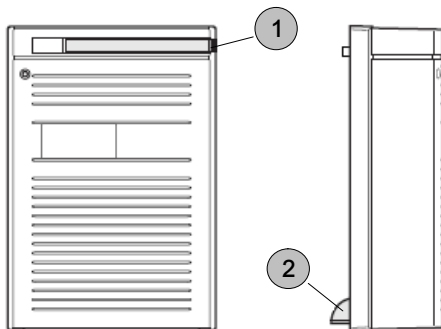

1	Locking lever
2	Cover guides

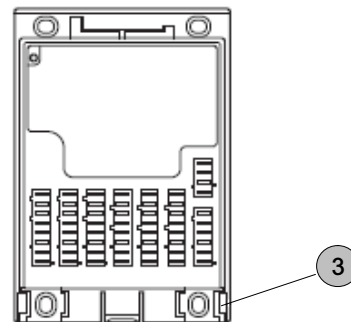

3	Insertion slots for cover guides
---	----------------------------------

1. Pull out the locking lever and rotate it towards you.
2. Place the cover diagonally onto the device. Insert the 2 cover guides, found at the bottom of the cover, into the slots.

3. Close the over onto the lower part. The 2 guides and slots provide a pivot point.
4. Move the locking lever back into its initial position. -> The cover is locked.

[info.kl@bucherhydraulics.com](mailto:info.kl@bucherhydraulics.com)

[www.bucherhydraulics.com](http://www.bucherhydraulics.com)

© 2022 by Bucher Hydraulics GmbH, D-79771 Klettgau

All rights reserved.

Data is provided for the purpose of product description only, and must not be construed as warranted characteristics in the legal sense. The information does not relieve users from the duty of conducting their own evaluations and tests. Because the products are subject to continual improvement, we reserve the right to amend the product specifications contained in this catalogue.

Classification: 470.710..