

M-14.5 a

Throttling Valve, 10 mm 6 mm
Semi-cartridge

Series RD

160 l/min, 350 bar

- Low cost model for use in manifold blocks
- self-cleaning metering areas
- self-locking adjusting screw and locknut
- Fine control in lower flow range (RDZ)
- Also available as stack valves in A and S
- RD -10 and RD -6 share the same cavity
- Optional hand knob available

Dimensions

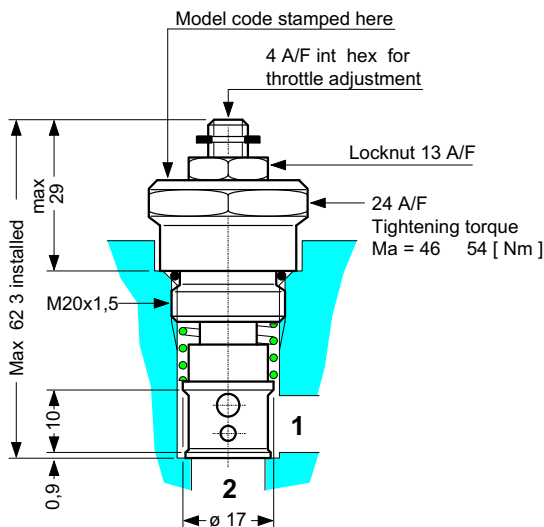

Cavit T p DF
see Data Sheet i-45.3



Symbol

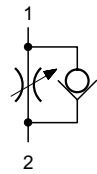

RD - 10
RD - 6
RDZ - 6

Description

Series RD throttling valves with reverse flow check valves are designed as semi-cartridges. The 2 sizes are distinguished only by differing throttle sleeves (item 3) and consequently by different controlled flow ranges (see performance characteristics).

In the direction 2 > 1 the valves allow free flow (cracking pressure 0,7 bar). In the direction 1 > 2, flow is governed by the throttle setting. The design of the throttle ensures automatic self-cleaning during reverse flow.

To set the throttle orifice, use a 4 A/F hexagon key in the end of the selflocking adjusting screw. The 13 A/F locknut provides additional security. Optionally available with hand knob adjuster.



1800-OILSOL
1800-645765

<https://oilsolutions.com.au/>

sales@oilsolutions.com.au

SCHEMATIC SECTION

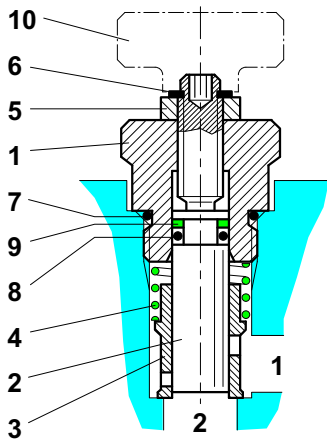

COMPONENTS AND SERVICE PARTS

It.	Qty.	Description	1*) Seal Kit No. DS-228 ▲ Service part		
1	1	1	1	Guide nut	24 A/F x 25
2	1	1	1	Adjusting screw	∅ 10 x 54,5
3	1	-		Throttle sleeve RDB-10	∅ 17 x 20,8
	-	1		Throttle sleeve RDB-6	∅ 17 x 20,8
	-	-	1	Throttle sleeve RDZ-6	∅ 17 x 20,8
4	1	1	1	Spring	iG = 6,5 1 x 17 x 20
5	1	1	1	Special hex. nut	M6 x 0,75
	1	1	1	Seal kit No. DS-228, comprising*):	
6	1*)	1	1	Circlip	∅ 7 Type SS
7	1*)	1	1	O-Ring No. 017	∅ 17,17 x 1,78
8	1*)	1	1	O-Ring No. 108	∅ 6,02 x 2,62
9	1*)	1	1	Back-up ring	∅ 10/6,7 x 1
10	(1)	(1)	(1)	Hand knob complete	

RDB-10
RDB-6
RDZ-6

TO ORDER SERVICE PARTS, STATE:

- complete unit model code from the nameplate, including design number.
- spare part description from above list.
- spare part item number from above list
- data sheet number, including issue date
- quantity required

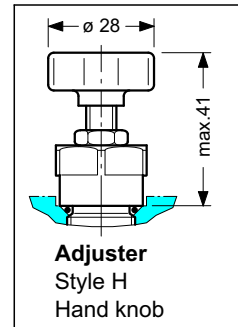

INSTALLATION AND SERVICING

ALL INSTALLATION AND SERVICING MUST BE CARRIED OUT WITH CARE, AND BY QUALIFIED PERSONNEL ONLY

when changing seals, the new seals should be thoroughly oiled or greased before they are fitted.

Use the correct tightening torque for the guide nut (It. 1).

PRINCIPAL CHARACTERISTICS

Type	Throttle / Check Valve semi-cartridge
Design	direct acting, spool type
Mounting method	screw in
Size	RDB-10 10 mm nominal RDB-6 6 mm nominal RDZ-6 6 mm nominal for cavity DF
Mass	0,11 kg
Mounting attitude	unrestricted
Flow direction	see symbol
Operating pressure	max. 350 bar
C.V. cracking pressure	approx. 0,7 bar in free flow direction

Fluids	hydraulic oils HL and HLP to DIN 51 524 other fluids - contact BHFRU
Fluid temperature range	-20° + 60° C
Viscosity range	10.... 300 cSt
Min. fluid cleanliness	18/14 to ISO 4406 CETOP RP70H 8 ... 9 to NAS 1638
Flow rate, Q max	RDB-10 = 160 l/min RDB-6 = 80 l/min RDZ-6 = 60 l/min see Performance Characteristics

PERFORMANCE CHARACTERISTICS (Oil viscosity 33cSt)

RDB-10

Δp -Q characteristics through check valve

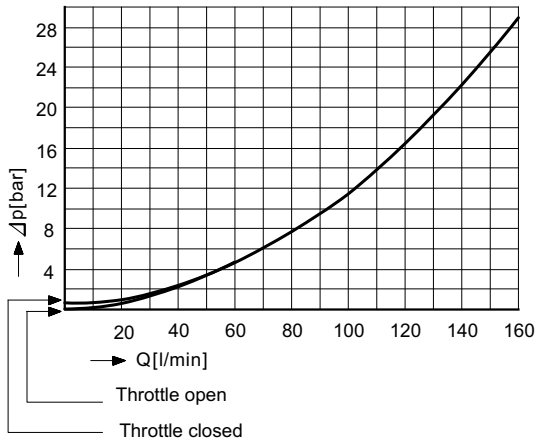

RDB-6

Δp -Q characteristics through check valve

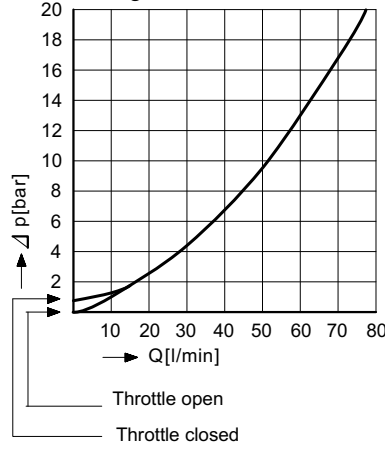

RDZ-6

Δp -Q characteristics through check valve

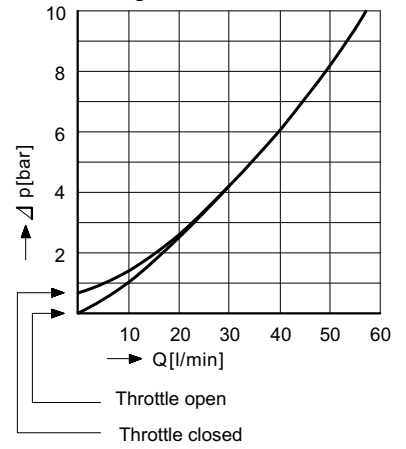

RDB-10 Δp -Q characteristics

at constant throttle settings.
Measured with bores 1 and 2 = \varnothing 10 mm

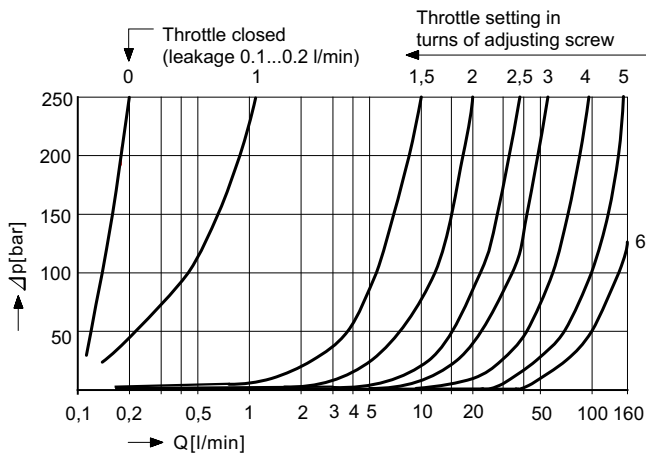

RDB-6 Δp -Q characteristics

at constant throttle settings.
Measured with bores 1 and 2 = \varnothing 7 mm

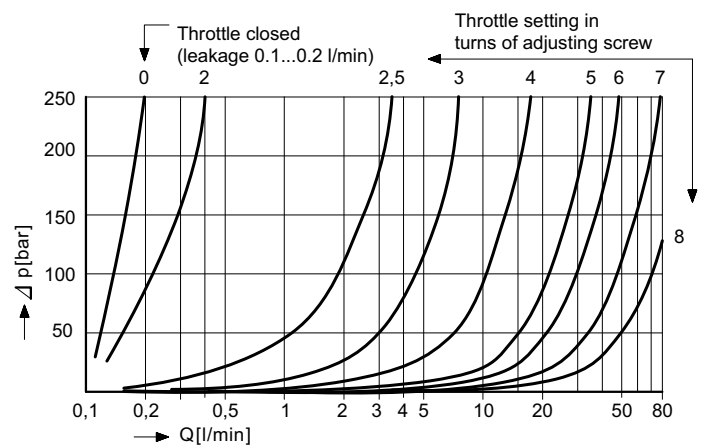

RDZ-6 Δp -Q characteristics

at constant throttle settings.
Measured with bores 1 and 2 = \varnothing 7 mm

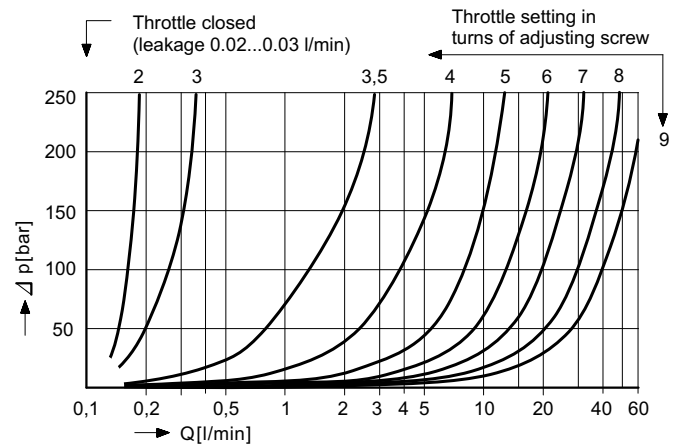

Ex..

RD	B	-	10	_	_	-	1
----	---	---	----	---	---	---	---

MODEL CODE KEY

RD = Semi-cartridge throttle valve with reverse flow C.V.

A ... Q = Standard model per relevant data sheet

Z ... R = Special features by arrangement

10 = Nominal size 10 mm (flows to ... 160 l/min)

6 = Nominal size 6 mm (flows to ... 80 l/min)

(Blank) = Hex. skt. screw adjuster (standard)

H = Hand knob adjuster (Option)

(Blank) = Nitrile seals (standard)

V = Viton seals

Special seals by arrangement

1 ... 9 = Design No. (omit when ordering)

RELATED DATA SHEETS

i - 45.3 = Cavity type DF

M - 20.1 = Stack-mounting Throttle valve with reverse Flow Check Valve Size 3

M - 22.1 = Stack-mounting Throttle valve with reverse Flow Check Valve Size 5