

SCHEMATIC SECTION

showing the relevant ports

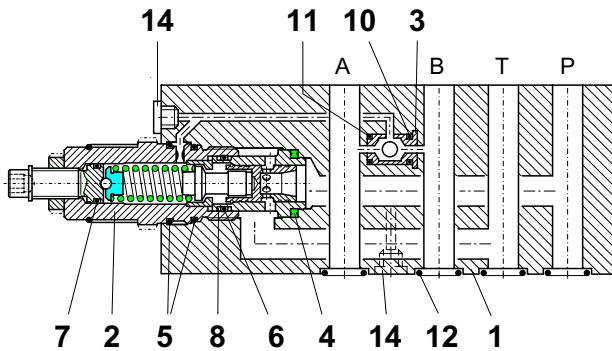

INSTALLATION AND SERVICING

MUST BE CARRIED OUT WITH CARE, AND BY QUALIFIED PERSONNEL ONLY.

At installation, be sure to mount the valve with the correct faces contacting the adjacent units and with all interface connections lining up properly.

When changing seals, the new seals should be thoroughly oiled or greased before fitting them to the valve.

Use the correct tightening torques when fitting the cartridge.

NOTE - before removing the cartridge, fully decompress the hydrostat spring by turning back the adjusting screw. If the hydrostat spring is compressed while the cartridge is removed, the cartridge neck will be pushed out of the cartridge head.

MAIN CHARACTERISTICS

Type	stacking inline hydrostat
Design	direct acting, sliding spool type
Mounting method	stack mounting
Size	ISO 4401 size 05 interface nominal 10 mm
Mass	2,95 kg
Mounting attitude	unrestricted
Flow direction	see symbol
Operating pressure	... 315 bar in P, A, B and T

Hydrostat spring	adjustable 5 ... 15 bar
Fluids	hydraulic oils HL and HLP to DIN 51 524 other fluids - contact HTF
Min. fluid cleanliness	18/14 to ISO 4406 / CETOP RP70H 8 ... 9 to NAS 1638
Fluid temperature range	-20° ... +60° C
Viscosity range	10 ... 300 cSt
Flow rate Q max.	... 60 l/min
Flow rate Q max. attainable at the actuator	... 60 l/min with spring $\Delta p = 15$ bar ... 23 l/min with spring $\Delta p = 5$ bar

COMPONENTS / SERVICE PARTS

It.	Qty.	Description	*) = part of seal kit no. DS-268 ▲ = available as service part	
1	1	Stacking body 50 x 70 x 116	type MY-10	
2	1	Hydrostat cartridge	type DWDP A-5D-10 ...	
3	1	Shuttle valve	type RW-2,5	
4	1	Seal kit no. DS-268, comprising *):		
4	1*)	Seal	$\varnothing 22,1 / 16,5 \times 2,5$	
5	2*)	O-ring no. 020	$\varnothing 21,95 \times 1,78$	N90
6	1*)	O-ring	$\varnothing 14,00 \times 2,00$	N90
7	1*)	O-ring no. 012	$\varnothing 9,25 \times 1,78$	N90
8	2*)	Backup ring	$\varnothing 18 / 15,2 \times 1,2$	
9				
10	1*)	O-ring	$\varnothing 5,50 \times 1,50$	N90
11	1*)	O-ring	$\varnothing 4,00 \times 1,50$	N90
12	5*)	O-ring no. 014	$\varnothing 14,12 \times 1,78$	N90
13				
14	2	Plug screw	G 1/8"	ED VSTI

TO ORDER SERVICE PARTS, STATE:

- complete unit model code from the nameplate, including the design number
- data sheet number, including issue date
- part item number from above list
- part description from above list
- quantity required

PERFORMANCE DATA Oil viscosity 33 cSt

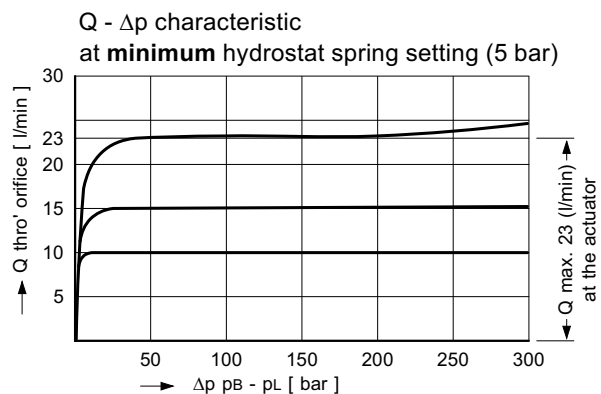
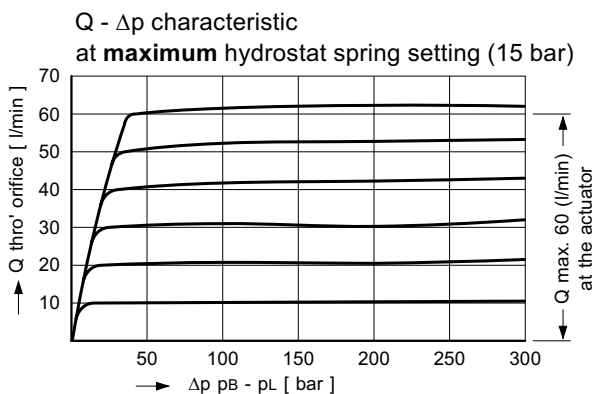

MODEL CODE KEY

Ex.

S D W D P B - 5 D - P - MY - 10 - S 0515 - 1

- S = stacking valve
- D = pressure function
- W = hydrostat
- D = direct acting
- P = with cartridge valve
- A ... Q = **standard** model per relevant data sheet
- Y ... R = special features by arrangement
- 5 = pressure control type 5
- D = with HTF cavity type DD
- P = function in P
- MY = stacking body, code MY
- 10 = ISO 4401 size 5 interface, nominal 10 mm
- S = with hex. skt. screw adjuster (**standard**)
- H = with hand knob adjuster
- Z = with lockable hand knob adjuster type Z4
- 0515 = hydrostat spring 5 ... 15 bar (stepless adjustment)
- (blank) = Nitrile seals (**standard**)
- V = Viton seals
- S = special seals by arrangement
- 1 ... 9 = design number (omit when ordering new units)

RELATED DATA SHEETS

- i - 41 DIN 24 340 A10 interface
- D - 28.55 Hydrostat cartridge, series DWDP A-5D-10 ...
- R - 32 Shuttle valve, series RW-2,5

APPLICATION EXAMPLE

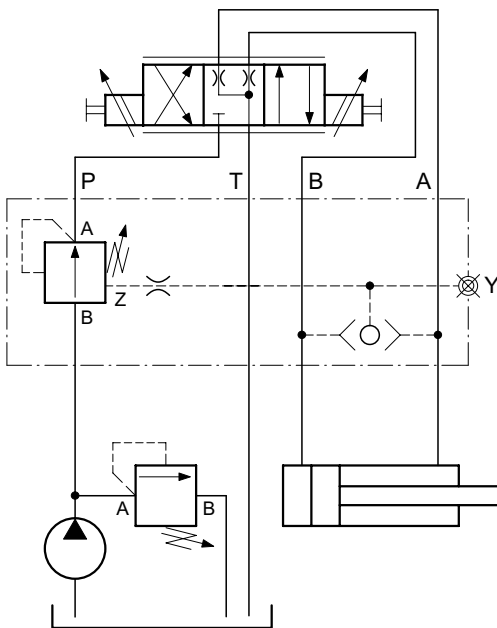

When combined with a downstream orifice, the inline hydrostat provides a two-way flow control function, with its associated benefits.

These are:

- the flow rate set by the orifice remains constant even as the load pressure fluctuates up or down

Option with pressure limiting

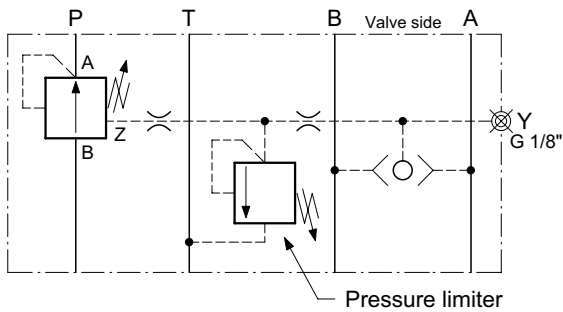

Function:

By including a pressure relief valve in the control line Z, the pressure at the outlet port A of the cartridge will be limited to the relief setting, regardless of the pressure at the inlet B. An actuator which operates at a low pressure can, in this way, be limited in the force it can produce (similar to a pressure reducing function).

Option with LS signal port

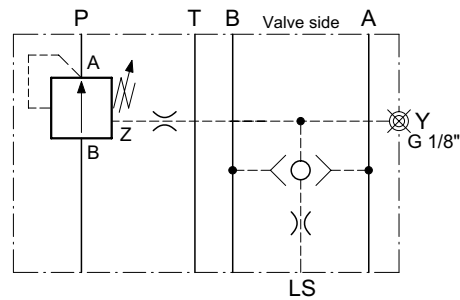

Function:

By combining several LS lines with the help of external check valves, the highest of the various load pressures in one or more stacking assemblies can be fed back to the LS pump or bypass hydrostat.