

PRESSURE SETTINGS

LOAD PRESSURE: to hold the maximum load without leakage, we recommend that the SNSA...-10 is set as follows:

$$p_E = p_L \cdot 1.3$$

p_E = valve pressure setting
 p_L = maximum load-induced pressure

Example: Load pressure p_L = max. 200 [bar]
 pressure setting p_E = 200 [bar] · 1,3 = **260 [bar]**

PILOT PRESSURE: the required pilot pressure is calculated as follows:

$$p_x = \frac{p_E - p_L}{i}$$

p_x = pilot pressure
 p_E = valve pressure setting
 p_L = effective load-induced pressure
 i = pilot ratio (see PRINCIPAL CHARACTERISTICS)

Example: Pressure setting p_E = 260 [bar]
 Load pressure p_L = eff. 180 [bar]
 Pilot ratio i = 4.5
 $p_x = \frac{260 [\text{bar}] - 180 [\text{bar}]}{4,5} = \text{approx. } 18 [\text{bar}]$

Application example

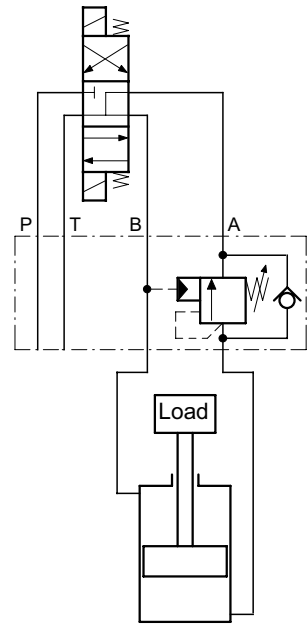

SCHEMATIC SECTION

showing the relevant parts

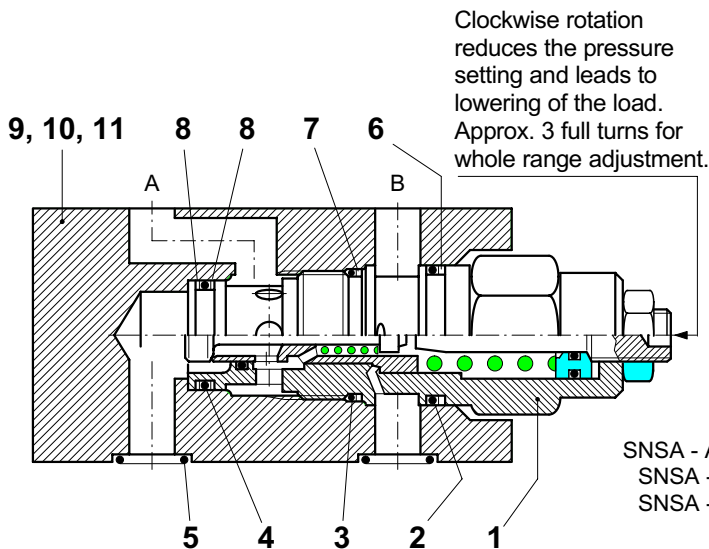

COMPONENTS AND SERVICE PARTS

It.	Qty.	Description		
1	2	1	1	Cartridge 350 bar type CBEG LCN
				Cartridge 175 bar type CBEG LDN
	1	1	1	Seal Kit No. DS-240, comprising *):
2	2*)		1	O-Ring No. 021 \varnothing 23,52 x 1,78 N90
3	2*)	1	1	O-Ring No. 020 \varnothing 21,95 x 1,78 N90
4	2*)	1	1	O-Ring No. 018 \varnothing 18,77 x 1,78 N90
5	5*)	5	5	O-Ring No. 014 \varnothing 12,42 x 1,78 N90
6	2*)	1	1	Backup ring 021
7	2*)	1	1	Backup ring 020
8	4*)	2	2	Backup ring 018
9	-	-	1	Stacking body 50 x 70 x 95 Typ KA-10
10	-	1	-	Stacking body 50 x 70 x 95 Typ KB-10
11	1	-	-	Stacking body 50 x 70 x 140 Typ KC-10

SNSA - AB - 10
 SNSA - B - 10
 SNSA - A - 10

TO ORDER SERVICE PARTS, STATE:

- complete unit model code from the nameplate, including Design Number.
- spare part description per above list.
- spare part item number per above list.
- data sheet number, including issue date
- quantity required

INSTALLATION AND SEVICING

ALL INSTALLATION AND SERVICING MUST BE CARRIED OUT WITH CARE, AND BY QUALIFIED PERSONNEL ONLY

At installation, be sure to mount the valve the correct way up. Do not confuse the flat surface (directional valve side)

and the surface with O-ring counterbores (the actuator side). When renewing seals, the new seals should be thoroughly oiled or greased before fitting them to the valve. Observe the correct tightening torque when installing the cartridge.

PRINCIPAL CHARACTERISTICS

Type	'sandwich' counterbalance valve	Adjustment range	pressure range M1 = 70 ... 175 [bar] (pilot ratio 4,5 : 1)
Design	pilot assisted, poppet type		pressure range M2 = 30 ... 105 [bar] (pilot ratio 3 : 1)
Mounting method	stack mounting	C.V. cracking pressure	approx. 0,3 [bar] (Standard) approx. 1,8 [bar] (contact HTF)
Size	ISO 4401 size 5 interface	Fluids	Hydraulic oils HL and HLP to DIN 51 524 other fluids - contact HTF
Mass	SNSA - A../B.. - 10... = 2,30 [kg] SNSA - AB.. - 10... = 3,50 [kg]	Minimum fluid cleanliness	18/14 to ISO 4406 / Cetop RP70H 8 ... 9 to NAS 1638
Mounting attitude	unrestricted	Fluid temp. range	- 20° ... +60° [C]
Flow direction	see symbols	Viscosity range	10 ... 300 [cSt]
Operating pressure	max. 350 [bar]	Flow rate, Q max.	120 [l/min] see perform. curves
Adjustment range	pressure range N1 = 140 ... 350 [bar] (pilot ratio 4.5 : 1) pressure range N2 = 70 ... 280 [bar] (pilot ratio 3 : 1)		

PERFORMANCE CHARACTERISTICS (Oil viscosity 33cSt)

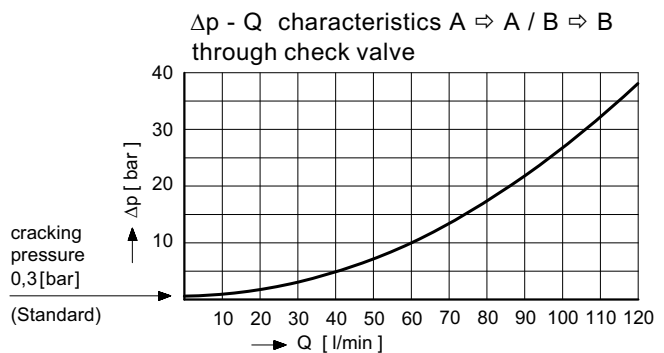
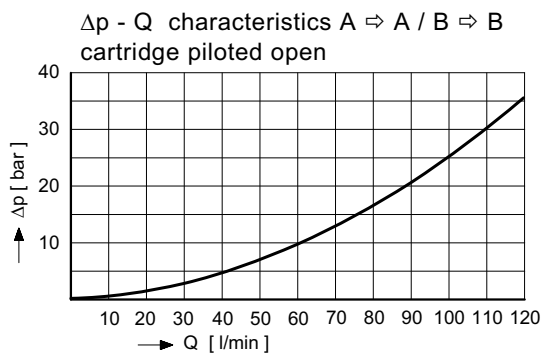

MODEL CODE KEY

- S = stack mounting
- N = counterbalance valve
- S = poppet type
- A ... Q = **Standard** model per current data sheet
- Z ... R = special features by arrangement (contact HTF)
- A = function in A
- B = function in B
- AB = function in A und B
- 10 = ISO 4401 size 5 interface
- S = screw adjustment
- N1 = pressure range 140 ... 350 bar (Normal, **standard** design)
pilot ratio 4,5 : 1
- N2 = pressure range 70 ... 280 bar (contact HTF)
pilot ratio 3 : 1
- M1 = pressure range 70 ... 175 bar (Medium, **standard** design)
pilot ratio 4,5 : 1
- M2 = pressure range 30 ... 105 bar (contact HTF)
pilot ratio 3 : 1

Valves are shipped with pressure set at the maximum for the specified pressure range e.g. if N1, then 350 bar.

- 03 = check valve cracking pressure 0,3 bar (**standard**)
- 18 = check valve cracking pressure 1,8 bar (contact HTF)
- (Blank) = Nitrile seals (**standard**)
- V = Viton seals
- special seals by arrangement (contact HTF)

Ex. SNSA - AB - 10 - S N1 - 03 -

D-38

SUBJECT TO CHANGE WITHOUT NOTICE

RELATED DATA SHEETS

i - 41 DIN 24340 size A10 interface

info.ch@bucherhydraulics.com

www.bucherhydraulics.com

© 2015 by Bucher Hydraulics AG Frutigen, CH-3714 Frutigen

All rights reserved.

Data is provided for the purpose of product description only, and must not be construed as warranted characteristics in the legal sense. The information does not relieve users from the duty of conducting their own evaluations and tests. Because the products are subject to continual improvement, we reserve the right to amend the product specifications contained in this catalogue.