

Overall Efficiency Optimized

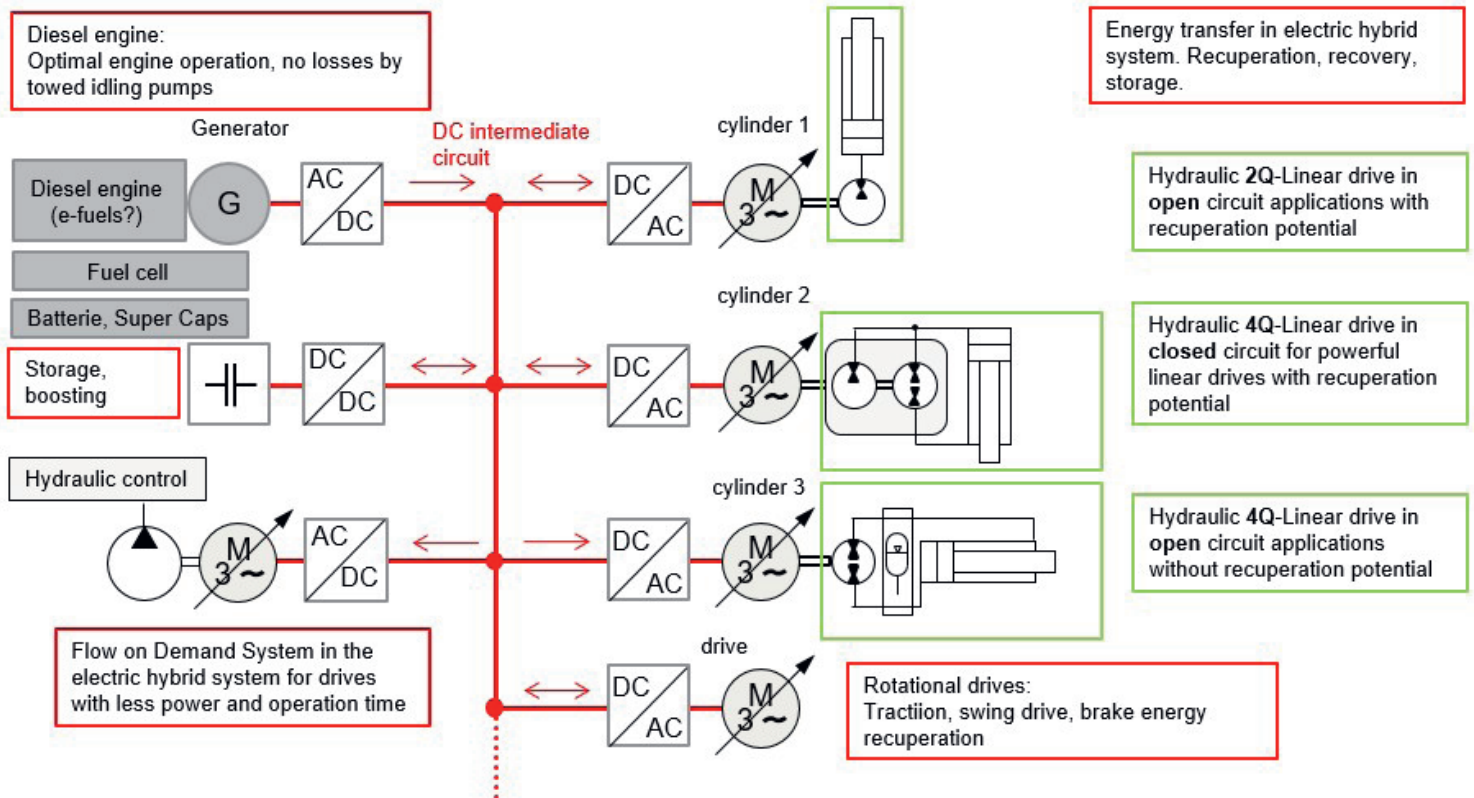

Hydraulics for electrically powered mobile machines

The EU, with the “Green Deal” initiative and the German government with the “Energy Efficiency Strategy 2050”, have politically stipulated that CO₂ emissions must be significantly reduced. These provisions will have a major impact on technical development in the next few years. Highly efficient drive systems, alternative and hybrid drives are increasingly used. These changes also affect mobile machines. They will likely be equipped with battery-powered electric drives, fuel cells, or diesel generators. The hydraulic system requires more efficient components and systems for precision movements.



Electric & hydraulic system



Challenges for the drive technology

For operators to work economically, electrically driven mobile machines must fulfill some important criteria. They are designed to achieve sufficiently long operating times without tedious recharging and to work reliably and quickly at high power levels, similar to former machines. The operating company also demands low noise emissions and low costs in terms of energy consumption and maintenance.

Efficiency the primary factor

Sufficient operating time can be achieved with a large dimensioned energy source or with a system with low power dissipation. However, this results in high expenses for the components. Using efficient components or systems can prove to be useful. Additionally, they reduce the need for cost-intensive energy storages. Electric drives already have a high efficiency over a wide operating range. Nevertheless, the hydraulics used today in mobile machines powered by diesel engines are not efficient enough. Improved systems need to be installed.

Limits of existing hydraulic systems

Hydraulic systems that adapt to the current volume and pressure requirements with the aid of variable displacement pumps, so-called load sensing systems (LS systems), are not optimal for electrified machines. The noise emissions of conventional variable displacement axial piston pumps are too high. They will be particularly prominent in electrified machines due to the absence of diesel engine noise. The level of efficiency of LS systems is not optimal throughout the entire operating range. The control deviation causes unnecessary losses in most operating points. Significant damping is occasionally necessary to operate the LS system without oscillation. This extends the response time considerably. Consequently, it is not advantageous to replace the diesel engine with an electric motor and leave the existing hydraulic system unchanged.

Inadequate electromechanics

Replacing hydraulic cylinders with electromechanical linear drives has proven to be impractical. The mechanical linear gears boxes are not suitable for the high loads of a construction machine. Furthermore, every electromechanical linear drive requires an electric motor with correspondingly high power. The installed power will be quite high in total, even though it is never needed at the same time.

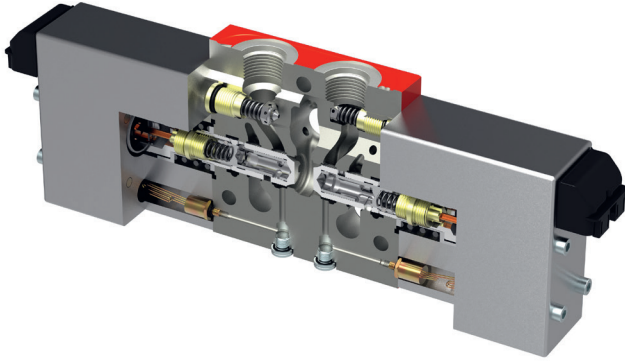

LVS12

More efficient “Flow-on-Demand” hydraulic

As a favorable compromise between high efficiency and low cost, an optimized hydraulic system can be used. Closed-circuit linear drives are an excellent choice for high-performance functions with a high potential for energy recovery. These are the ones with the lowest energy losses. Each linear function requires a combination of electric motor and pump, comparable to electromechanical linear drives. It does not make sense for all functions.

For precision movements, valve controls with “Flow on Demand” (FoD) are an economical alternative. Hydraulic control blocks with separate control edges, such as the LVS12 valve from Bucher Hydraulics, reduce power loss, and enable movements to be more dynamic; therefore, the effectiveness of the machine is further increased. It is possible to combine variants of electric drives and hydraulic systems optimally in an electrical system with a DC intermediate circuit. For example, the hydraulic pump can be operated as a fixed displacement pump with variable speed. The speed of the electric motor must be set accordingly. Bucher Hydraulics’ FoD software makes this possible without additional effort for the hydraulics user. The system calculates the required optimum speed based on the valve actuation characteristics. The result of the FOD system is always the lowest possible pressure at the pump. It depends on the current load and pressure losses. Pressure losses can be minimized by optimizing the system design. It is particularly advantageous that the control pressure difference required in the LS system is eliminated.

In the FoD system, the valve opening and pump speed are controlled simultaneously. As a result, the responding behavior is very fast and direct, comparable to the performance of electric travel drives. The control system works stable without oscillations. This allows the operator to drive the machine more effectively. The FoD system also offers additional advantages for controlled functions, such as the assistance control systems. Bucher Hydraulics’ FoD software features additional options that are not available with a traditional LS system.

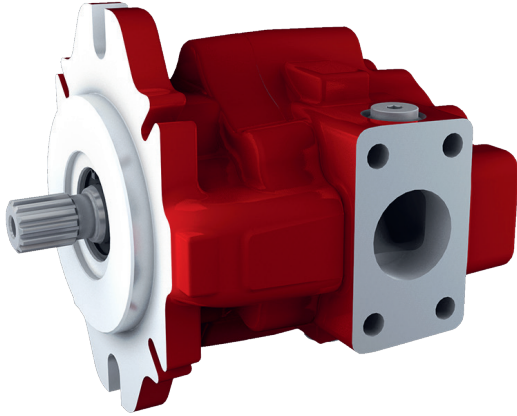

AX pump

Pump efficiency is crucial

In variable speed operation, the pump is of particular importance to meet the special requirements of a FoD system. The pump is the heart of the system. Comparable to the efficiency of high-quality electric motors, it must be operable at 92 to 94 % efficiency over a wide operating range. This minimizes the need for costly battery capacity and extends the achievable service life. Reducing power dissipations at the hydraulic pump, for example, from 5 to only 2.5 kW, contributes significantly to the energy-efficient operation of the machines. The efficiency chain further enhances this effect. Especially suitable for such drive combinations are the AX series hydraulic pumps of Bucher Hydraulics.

Even at high performance, the noise level is low and pleasant, as expected by end users. The pumps can be started at high pressure and operated at very low speed without premature and excessive wear. Due to low leakage and the high number of pistons, a smooth cylinder movement can be achieved even at low speeds. This is particularly beneficial for positioning work and large booms. The design principle with consistent hydrostatic balance of the components makes these pumps particularly reliable. With AX pumps and FoD software, the hydraulic systems of Bucher Hydraulics perfectly meet the requirements of electrified machines.

Interview with Dierk Peitsmeyer: Hydraulics for electrically powered mobile machines



Dierk Peitsmeyer
Product Portfolio Manager
Bucher Hydraulics, Klettgau

The call for climate protection and lower CO₂ emissions also goes to the manufacturers of mobile machines for agriculture and forestry as well as for civil engineering and building construction machines. Which drive systems will be usable in the future to meet the demands for high power density and efficient, economical operation with minimized pollutant emissions?

We spoke about it to Dierk Peitsmeyer, Product Portfolio Manager at Bucher Hydraulics in Klettgau.



Mr. Peitsmeyer, under what conditions will product planners and designers have to develop mobile and construction machines in the near future?

Dierk Peitsmeyer: The decrease in CO₂ emissions will have a major impact on technical development in the coming years. The EU with the “Green Deal” initiative and the German government with the “Energy Efficiency Strategy 2050” have set the political objectives. To implement the strategy, highly efficient drive systems, alternative drives, and hybrids will become increasingly important. All this will also affect mobile machines. Electrification with the energy sources battery, fuel cell, or diesel generator requires more efficient components and systems for precision movements.

This implies that in the future, not only passenger cars but also mobile machinery will be driven hybrid or even fully electric, for example, earthmoving, forestry, and agricultural applications. What do operators essentially demand from these “alternatively” driven machines?

Dierk Peitsmeyer: An important factor is undoubtedly a sufficiently long operation time without recharging the batteries, which takes a lot of time. Besides, the operators naturally keep an eye on the economic operation. They expect low costs and little effort in energy consumption, maintenance, service, and repair. In addition, alternatively driven machines must also function very reliably and maintenance-free over long periods of time. The operating company can only then work economically. Another aspect related to environmental protection is definitely noise emission. Mobile machines should be as quiet as possible. It will certainly be crucial that the machines are at least up to the usual standard or better for daily operation and acceptance of the operator. To achieve high performance, short reaction times are of vital importance when controlling the functions.



What options are available to meet these requirements?

Dierk Peitsmeyer: Sufficient operating time can be achieved with a large dimensioned energy source or low power dissipation. However, a large battery or fuel cell is relatively expensive. Efficient components and an effective system can prove to be a more sensible approach depending on the load spectrum, as the energy costs are also lower. Electric drives already offer high efficiency over a wide operating range. Nevertheless, the hydraulics used today in mobile machines powered by diesel engines are not efficient enough.

LS (Load Sensing) - systems with variable displacement pumps do not optimally meet the criteria for electrified machines. The noise emissions of conventional variable displacement axial piston pumps are too high. They will be particularly prominent in electrified machines due to the absence of diesel engine noise. The level of efficiency is not optimal throughout the entire operating range. The LS control deviation causes unnecessary losses in most operating points. Significant damping is occasionally necessary to operate the LS system without oscillation. This extends the response time considerably.

Consequently, it is not advantageous to replace the diesel engine with an electric motor and leave the existing hydraulic system unchanged. Replacing hydraulic cylinders with electromechanical linear drives has proven to be impractical. The mechanical lineargears boxes are not suitable for the high loads of a construction machine. Furthermore, every electromechanical linear drive requires an electric motor with correspondingly high power. As a result, the installed power is relatively high, even though it is never driven simultaneously. An optimized hydraulic system is a compromise between efficiency and cost. For high-performance functions with a high energy recovery potential, closed-circuit linear drives are an excellent choice. They have the lowest losses. Each linear function requires a combination of electric motor and pump, comparable to electromechanical linear drives. It does not make sense for all functions.

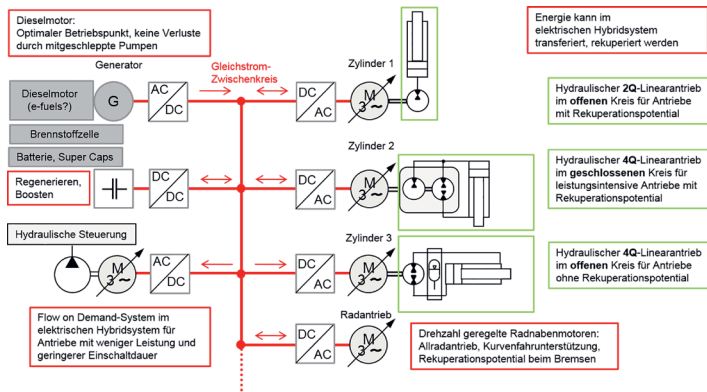

Efficiently combined: electric-hydraulic drive systems optimize overall efficiency

Therefore, you consider the technical options shown to be insufficient or a compromise where you have to accept too many restrictions. What alternatives are there to meet the partly contradictory demands much better?

Dierk Peitsmeyer: For precision movements, valve controls with “Flow on Demand” (FoD) are an economical alternative. Hydraulic control blocks with separate control edges, such as the LVS12 from Bucher Hydraulics, reduce power loss, and enable movements that are more dynamic; therefore, the effectiveness of the machine is further increased. It is possible to combine variants of electric drives and hydraulic systems optimally in an electrical system with a DC intermediate circuit.

The pump is operated as a fixed displacement pump with variable speed. The electric motor speed is calculated by the Bucher Hydraulics FoD software using the valve actuation characteristics. The control pressure difference required in the LS system is eliminated. The result of the FoD system is always the lowest possible pressure at the pump. It depends on the current load and pressure losses. The pressure losses can be minimized by an optimized system design.

In the FoD system, the valve opening and pump speed are controlled simultaneously. As a result, the responding behavior is very fast and direct, comparable to the performance of electric travel drives. The control system works stable without oscillations. This allows the operator to drive the machine more effectively. The FoD also offers additional advantages for controlled functions, such as assistance control systems. Our FoD software features additional options that are not available with a traditional LS system.

Flow on Demand
HIGHER PRODUCTIVITY, STABILITY AND ENERGY SAVINGS

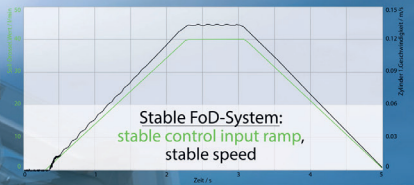
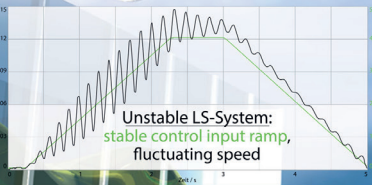

Load Sensing System (LS)

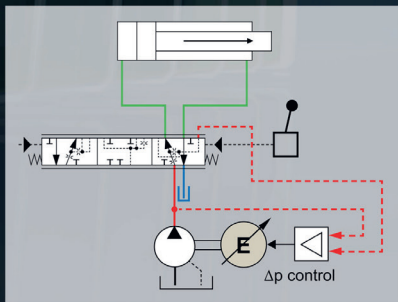

- ⊖ Long reaction time = less productivity
- ⊖ Pump- Δp -control leads to fluctuations
⇒ more LS-damping required
- ⊖ LS controller setting too high
= energy loss

Flow on Demand System (FoD)

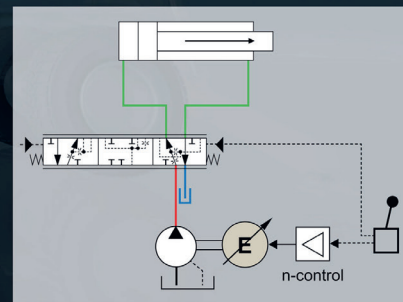

- ⊕ Fast reaction = higher productivity
- ⊕ Electronic pump control
⇒ stable without dampings
- ⊕ Pump pressure depends on load and resistance
= stability and energy saving

Dynamic and stable function with Flow on Demand

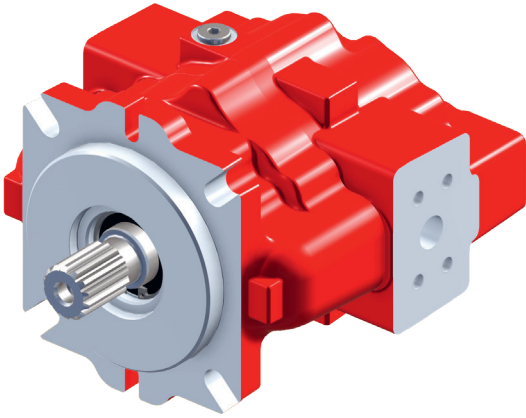

Highly efficient and quiet - Bucher Hydraulics AX pump

This certainly requires a much greater effort for control technology as well as hardware and software development by the machine manufacturer. To what extent are hydraulics manufacturers able to offer economic solutions in this area?

Dierk Peitsmeyer: With Bucher Hydraulics' FoD software, the user has no trouble generating the optimal electric motor speed. In variable speed operation, the pump is of particular importance to meet the specific requirements of mobile hydraulics. The pump is the heart of the system. Comparable to the efficiency of high-quality electric motors, it must be operable at 92 to 94 % efficiency over a wide operating range. This minimizes the need for costly battery capacity. There is a significant difference whether 5 kW or only 2.5 kW power loss is generated by the pump. The efficiency chain further enhances this effect.

At Bucher Hydraulics, we offer our AX pumps as the optimum solution. Even at high performance, the noise level is low and pleasant, as expected by end users. The AX pumps can be started at high pressure and operated at very low speed without premature and excessive wear. Due to low leakage and the high number of pistons, smooth cylinder movement can be achieved even at low speeds. This is advantageous for precise positioning or when large booms are involved. The design principle with consistent hydrostatic balance of the components makes these pumps particularly reliable. With AX pumps and FoD software, the hydraulic systems of Bucher Hydraulics perfectly meet the requirements of electrified machines and thus make a vital contribution to the future economical and productive use of electrified machines.

Smart Solutions. Superior Support.

Contact for reader inquiries

Bucher Hydraulics GmbH
D-79771 Klettgau
info.kl@bucherhydraulics.com
www.bucherhydraulics.com

Contact for editors:

Dierk Peitsmeyer
Product Portfolio Manager
Tel.: +49 (0)7742 85 21 78
dierk.peitsmeyer@bucherhydraulics.com