



Fleet and Heavy Duty TECHTIPS



Troubleshooting V-ribbed belt noise

Terms such as chirp, squeal, rumble and yelp have been used in the trucking industry to describe noises caused by friction-induced vibration in engine accessory drive belts. The following report, based on testing by Gates Corporation, examines primary causes and remedies for this problem.

Under-the-hood harmonics

Intermittent belt chirp that increases in frequency as the engine is revved up can be the result of belt vibration caused by misaligned drive pulleys – a leading cause of belt noise. As a misaligned V-ribbed belt span enters the grooves of a pulley, initial contact is made with only one side of the V-groove. The greater the misalignment angle, the greater the radial sliding length experienced by the belt ribs as the belt seats in the pulley causing frictional vibrations, or chirping (see Figure 1).

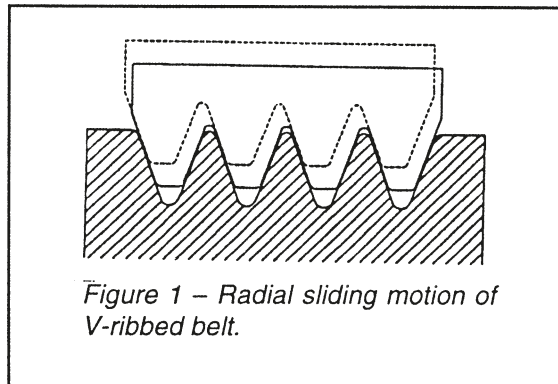
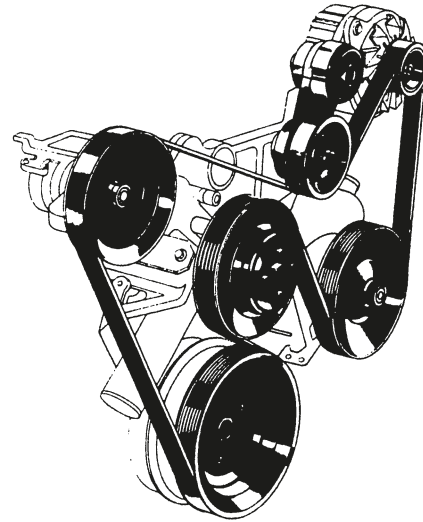

Figure 1 – Radial sliding motion of V-ribbed belt.

Low belt tension, contamination and belt vibration are other common sources of belt noise. A screeching or squealing noise that occurs when pulling away from a stop normally indicates a lack of tension; check belt tension and automatic tensioners.

A tapping or grinding noise caused by a pebble imbedded in the belt is a common occurrence. Grinding sound also can result from damaged bearings, which must be replaced, aligned and lubricated to eliminate the noise and further damage.



To the educated ear, drive belt noise can be as distinctive as notes on a musical scale.

Vibration and noise can develop over time as drive components such as pulleys and spring tensioners wear out of tolerance, as bearings and brackets loosen, or as belts wear and stretch.

Diagnosing the problem

In ongoing studies at the Gates Belt Testing Laboratory in Denver, engineers have gained the following insights to noise resulting from misalignment:

- (1) Chirp noise caused by drive misalignment occurs upon entry of the span into the pulley as belt ribs seat into the pulley grooves, not as the belt exits.
- (2) Belts are less likely to generate misalignment noise when they are in new condition. As belts wear, they develop a smooth, glossy surface, which increases the likelihood for noise. This wear-in process is accelerated when misalignment conditions exist in the drive.
- (3) The angle between belt span and pulley is the critical factor responsible for causing the "chirp" associated with misalignment noise. Misalignment angle can result from many different combinations of pulley positions –



parallel and angular are two typical examples (see Figure 2).

- (4) Misalignment noise occurs most frequently on the shortest spans in a drive, which most often arise between a backside pulley and an adjacent accessory pulley. Proper pulley alignment is particularly critical in these locations.
- (5) Flat or crowned pulleys have no grooves to guide the belt and can be a common source of drive misalignment.
- (6) Smaller diameter pulleys exhibit less sensitivity to misalignment noise due to their smaller area of sliding contact between the belt and pulley.
- (7) Misalignment noise is generally loudest at idle speed and diminishes with increasing engine rpm.
- (8) The presence of high humidity (or a damp belt) often increases the likelihood for misalignment noise to occur.



Figure 2 – Parallel misalignment (left) and angular misalignment (right).

In the shop

Whenever a vehicle operator complains of belt noise, it is important to determine the type of noise and under what circumstances it occurs. A solution to a noise problem caused by drive misalignment is not likely to resolve a slip noise problem that may be caused by insufficient tension or some other problem. Find out if the problem is more noticeable in the morning while the engine is cool (cool, damp belt). Is the noise loudest at idle speed, or when accelerating or shifting gears (rapid changes in engine speed can cause a belt to slip)?

Next, attempt to recreate the problem in the service bay. Using a spray bottle filled with water, mist the belt lightly. If the noise level recedes for several seconds, then returns louder, a misalignment problem is indicated. If the noise immediately increases after the belt is sprayed, slipping is indicated.

If the water spray test is inconclusive, or not successful at diagnosing the problem, attempt to remove the noisy belt and re-install it so that the belt runs in the opposite direction. Because misalignment noise is influenced by the direction of misalignment in the drive, flipping the belt around in this manner *will eliminate or significantly diminish (temporarily) any noise caused by drive misalignment. If the noise*

remains unchanged, the problem is not likely related to drive alignment.

In actual applications, the highest occurrence of belt noise due to misalignment comes from short belt spans entering large diameter pulleys. Inspect all flat pulleys and the tensioner idler for proper belt tracking when the engine is running. Belts should track in the center of these pulleys. If the pulley has a worn track, but the belt isn't running in this track, misalignment is indicated. Also, look for replaced drive components, such as a rebuilt alternator, which may have been improperly installed, resulting in pulley misalignment.

Corrective action

Failure to correct conditions responsible for belt noise will result in the problem returning, usually

within 5000km or less.

If the problem is drive-related, depending on the degree of misalignment, it may be possible to modify the noise level by installing a new belt with noise-resistant properties.

Gates engineers have developed new elastomeric compounds that are noise-resistant under various environmental and wear conditions. These new belts feature additives that enable them to slide easily into and out of the pulley. This low-noise construction helps to eliminate belt noise from most misalignment situations.

In the case of severe misalignment, repositioning of drive components using shims, or by changing the press fit of the pulley or the shaft, may be required. Pulley alignment and tension must be correct on all V-ribbed belt applications for the drive to operate properly.



www.gatesaustralia.com.au/transportation