



OIL SOLUTIONS

PO Box 38
Strathfieldsaye, VIC, 3551
1800 OIL SOL
1800 645 765
sales@oilsolutions.com.au
www.oilsolutions.com.au
"For All Your Hydraulic Needs"



Trust it

LANTERNE DI ACCOPPIAMENTO
GIUNTI DI TRASMISSIONE
ACCESSORI

BELLHOUSING
DRIVE COUPLINGS - ACCESSORIES





Pompa oleodinamica

Le lanterne o campane di accoppiamento, sono utilizzate quali elementi di collegamento meccanico tra motore elettrico a flangia unificata e pompa oleodinamica per realizzare il gruppo motopompa. Le lanterne di questa gamma, consentono un assemblaggio ottimale tra motori elettrici a flangia unificata fino a 270 HP e la maggior parte delle pompe oleodinamiche presenti sul mercato internazionale. Costruite in lega di alluminio si dividono in due categorie:

LANTERNA MONOBLOCCO

realizzata in un unico pezzo

LANTERNA COMPONENTIBILE

realizzata in più pezzi

- lanterna base + flangia
- lanterna base + distanziale + flangia

La soluzione con la lanterna componibile, viene adottata nei seguenti casi:

1. L'altezza della lanterna monoblocco non è sufficiente a contenere gli alberi del motore e della pompa.
2. Le caratteristiche di fissaggio della pompa non sono compatibili con le dimensioni della lanterna monoblocco.

Dati indispensabili per la scelta della lanterna

1. Potenza del motore (tab. motori vedi pag. 21/29).
2. Caratteristiche dimensionali della pompa oleodinamica.

Hydraulic pump

Bellhousings are the mechanical elements used to connect an electric motor equipped with standard flange to a hydraulic pump, thus forming the pump/motor unit. The bellhousings of this range allow to establish a perfect assembly between electrical motors with standard flange up to 270 kW and the majority of the hydraulic pumps available on the world market. They are produced in aluminium alloy and can be divided into two categories:

SINGLE PIECE BELLHOUSING

made of a single piece

COMPOSITE BELLHOUSING

made of several components

- base bellhousing + flange
- base bellhousing + distance ring + flange

Composite bellhousings are employed under the following conditions:

1. The dimension "H1" of the base bellhousing is inferior to the summed length of motor and pump shafts plus spider.
2. The fixing points of the pump are not compatible with the fixing holes of the bellhousing.

Necessary indications

for the choice of the correct bellhousing

1. Power of the motor (tab. motors see pag. 21/29).
2. Dimensional data of the hydraulic pump.

MATERIALI

Lanterne	Lega di alluminio per pressofusione, conchiglia o fusioni in terra
Anelli di centraggio	Lamiera zincata tranciata
Temp. di esercizio	-30°C +80°C

MATERIALS

Bellhousings	Alluminium alloy for die-and shell-casting
Centering rings	Cut and zinc-plated sheet metal
Working temp.	-30°C +80°C

COMPATIBILITÀ CON I FLUIDI

Tutte le parti che vengono esposte all'ambiente marino devono essere protette con trattamenti superficiali oppure con vernici adeguate all'impiego. Specificare in fase di ordinazione del materiale all'ufficio commerciale.

COMPATIBILITY WITH MARINE SURROUNDINGS

On request all our bellhousings can be supplied with specific coating or surface treatment that makes them suitable for use in marine surroundings.

SCelta DELLA LANTERNA

1. Sommare le lunghezze degli alberi di motore elettrico e pompa oleodinamica, aggiungendo lo spessore dell'inserito elastico o del manicotto in poliammide, necessario per la potenza di motore che si sta utilizzando.
2. Scegliere la lanterna nella tab. 1 - 2 - 3 - 4 tenendo presente che la somma precedente deve essere $< 0 =$ alla lanterna scelta.
3. Verificare che le caratteristiche di fissaggio della pompa oleodinamica siano compatibili con le dimensioni della lanterna scelta.

SELECTION OF THE CORRECT BELLHOUSING

1. Sum the length of motor shaft and pump shaft, then add the thickness "I" of the rubber spider or the dimension "G" of the polyamid ring of the coupling suitable for the power of the selected motor.
2. Choose the suitable bellhousing in table 1, 2, 3 or 4, making sure that the sum calculated as per point 1. is equal or inferior to the dimension "H1" of the bellhousing.
3. Check the correspondance of the fixation points of the pump with those of the bellhousing.

APPLICAZIONI SPECIALI

Per tutte le applicazioni che non rientrano nei casi normali specificati in questo catalogo contattare l'ufficio commerciale della OMT Group per un eventuale studio di fattibilità.

SPECIAL APPLICATIONS

The present leaflet covers only standard applications. Our technical department is equipped to study on request special solutions for particular applications. Please contact our commercial department for further information.

LANTERNA MONOBLOCCO SINGLE PIECE BELLHOUSING



Tabella / Table 1

Potenza motore 4 poli 1450 giri/1' Motor power 4 poles 1450 revs/min			Lanterna / Bellhousing											Codice per l'ordinazione della lanterna senza lavorazione lato pompa Part number of bellhousing without machining on pump side			
Taglia/Size	kW	HP	Tipo Type	Dimensioni / Dimensions (mm)											H1	H2	
				D1 min	D2	D3	D4	D5	D6	D7	N fori N. of holes	D8	N fori N. of holes				
80-90	0,55÷1,5	0,75÷2	TH20A	45	130	135	130	165	200	12	4	M10	4	95	16	TH20A-45x	
80-90	0,55÷1,5	0,75÷2	THB20	50	130	135	130	165	200	12	4	M10	4	113	16	THB20-50x	
80-90	0,55÷1,5	0,75÷2	TH1	63	130	135	130	165	200	12	4	M10	4	126	16	TH1-63x	
100-112	2,2÷4	3÷5,5	THB25	50	176	183	180	215	250	14	4	M12	4	112	21	THB25-50x	
100-112	2,2÷4	3÷5,5	TH2	63	176	183	180	215	250	14	4	M12	4	136	21	TH2-63x	
132	5,5÷9	7,5÷12,5	THB30	80	230	235	230	265	300	14	4	M12	4	130	21	THB30-80x	
132	5,5÷9	7,5÷12,5	TH3	80	230	235	230	265	300	14	4	M12	4	170	21	TH3-80x	
160-180	11÷22	15÷30	L35C	80	240	253	250	300	350	18	4	M16	4	178	25	L35C-80x	
160-180	11÷22	15÷30	TH4	80	240	253	250	300	350	18	4	M16	4	195	25	TH4-80x	
200	30	40	TH15	100	235	295	300	350	400	18	4	M16	4	206	25	TH15-100x	
225	37÷45	50÷60	TH18	100	260	350	350	400	450	18*	8*	M16	8	280	25	TH18-100x	
250-280	55÷90	75÷125	TH19	100	300	450	450	500	550	18*	8*	M16	8	290	30	TH19-100x	
315S	110	150	TH20	100	300	550	550	600	660	22*	8*	M20	8	295	35	TH20-100x	

*Sede per testa bullone non disponibile - Bolt head counterbore not available

LANTERNE COMPONENTI COMPOSITE BELLHOUSINGS

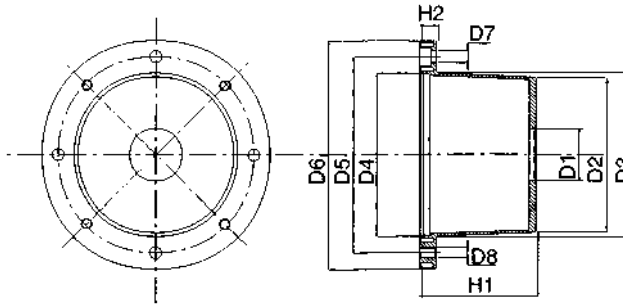
LANTERNA BASE / BASE BELLHOUSING

tipo / series **B**

** In funzione della flangia aggiuntiva

** Dimension related to used flange



Tabella / Table 2

Potenza motore 4 poli 1450 giri/1' Motor power 4 poles 1450 revs/min			Lanterna / Bellhousing													
Taglia/Size	kW	HP	Tipo Type	Dimensioni / Dimensions (mm)											H1	H2
				D2	D3	D4	D5	D6	D7	N fori N. of holes	D8	N fori N. of holes				
80-90	0,55÷1,5	0,75÷2	B2A	126	137	130	165	200	12	4	M10	4	95	16		
80-90	0,55÷1,5	0,75÷2	B20	126	137	130	165	200	12	4	M10	4	113	16		
80-90	0,55÷1,5	0,75÷2	B1	126	137	130	165	200	12	4	M10	4	126	16		
100-112	2,2÷4	3÷5,5	B25	126-171	186	180	215	250	14	4	M12	4	112	21		
100-112	2,2÷4	3÷5,5	B2	126-171	186	180	215	250	14	4	M12	4	136	21		
132	5,5÷9	7,5÷12,5	B30	126-171-220	235	230	265	300	14	4	M12	4	130	21		
132	5,5÷9	7,5÷12,5	B3	126-171-220	235	230	265	300	14	4	M12	4	170	21		
160-180	11÷22	15÷30	B35	237	253	250	300	350	18	4	M16	4	155	25		
160-180	11÷22	15÷30	B4	237	253	250	300	350	18	4	M16	4	195	25		
200	30	40	B40	237	295	300	350	400	18	4	M16	4	155	25		
200	30	40	B15	237	295	300	350	400	18	4	M16	4	206	25		
225	37÷45	50÷60	B45	237	350	350	400	450	18*	8*	M16	8	185	25		
225	37÷45	50÷60	B18	237	350	350	400	450	18	8	M16	8	280	25		
250-280	55÷90	75÷125	B55	237	450	450	500	550	18*	8*	M16	8	186	30		
250-280	55÷90	75÷125	B19	237	450	450	500	550	18*	8*	M16	8	290	30		
315S	110	150	B6A	237	550	550	600	660	22*	8*	M20	8	230	35		
315S	110	150	B66	237	550	550	600	600	22*	8*	M20	8	295	35		
355	160÷200	220÷270	B8	237	685	680	740	800	23*	8*	M20	8	315	60		

*Sede per testa bullone non disponibile - Bolt head counterbore not available

DISTANZIALI / DISTANCE RINGS

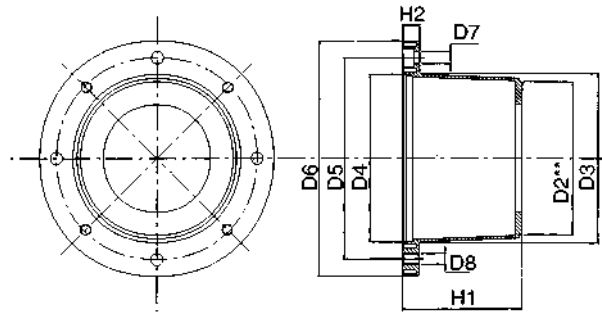
tipo / series **D**



Tabella / Table 3

Lanterna base Base bellhousing	Distanziale / Distance ring				Flange complementari Additional flanges	Codice per l'ordinazione del distanziale singolo Part number of distance ring
	Tipo Type	Dimensioni / Dimensions (mm)				
Tipo / Type		D2	D3	H1	Tipo / Type	
B35-B4-B40-B15 B45-B18-B55-B19 B6A-B66 B8	D20	250	237	20	Q4* - T1* - T2A	D - 20
	D30	250	237	30	Q4* - T1* - T2A	D - 30

N.B.: In caso di necessità è possibile realizzare distanziali più alti di 30 mm con la combinazione di quelli disponibili. Esempio: D40 = D20 + D20
N.B.: Several units can be combined to obtain lengths superior to 30 mm. Example: D40 = D20 + D20

FLANGE / FLANGES

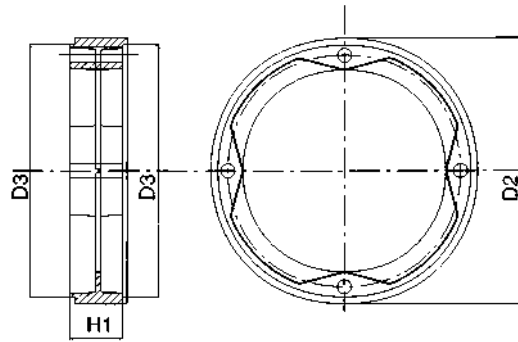
tipo / series **Q**

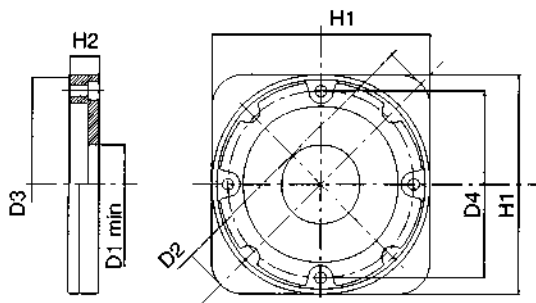

FLANGE / FLANGES

tipo / series **T**



Tabella / Table 4

Lanterna base Base bellhousing	Flange / Flanges							Codice per l'ordinazione della flangia senza lavorazione lato pompa Part number of flanges without machining of pump side
	Tipo Type	Dimensioni / Dimensions (mm)						
Tipo / Type		D1 min	D2	D3	H1	H2	D4	
B2A-B20-B1 B25-B2-B30-B3	Q1A	60	170	126	130	17	115	Q1A - 60x
B25-B2-B30-B3	Q2A	80	225	171	176	24	150	Q2A - 80x
	Q4G	224	350	237	255	70	218	Q4G - 224x
B35-B4-B40-B15 B45-B18-B55-B19 B6A-B66 B8	Q4M	165	350	237	255	20	218	Q4M - 165x
	T1A	80	247	237	-	65	218	T1A - 80x
	T1D	80	247	237	-	50	218	T1D - 80x
	T1G	80	247	237	-	35	218	T1G - 80x
	T2A	150	290	237	-	20	218	T2A - 150x
B30 - B3	T3A	80	228	220	-	50	184	T3A - 80x
	T3B	80	228	220	-	45	184	T3B - 80x

LANTERNA / SILENCED BELLHOUSINGS

 tipo / series **BS**

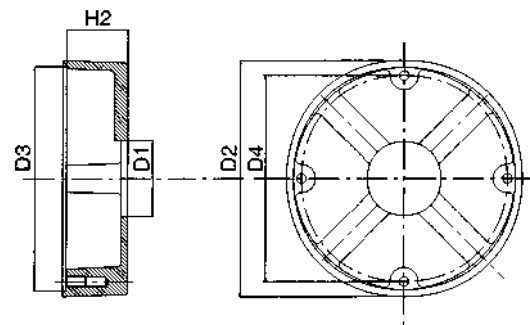
Le lanterne insonorizzate, sono state progettate per ovviare ai problemi di rumorosità degli impianti. Questo tipo di particolare, permette di collegare in modo elastico il motore elettrico alla pompa oleodinamica e, grazie ad un anello in gomma antiolio, interposto tra lanterna base e flangia, viene ridotto notevolmente il propagarsi delle onde sonore dovute alle vibrazioni degli organi meccanici in movimento.

Dalle prove effettuate è stata riscontrata una diminuzione di rumorosità di 5 dB (A).

Grazie alla grande flessibilità, può essere montata nella versione monoblocco oppure nella versione componibile, utilizzando le stesse flange e gli stessi distanziali delle lanterne tradizionali di produzione OMT Group.

N.B.: Nelle lanterne di tipo BS non è possibile eseguire forature, con fori lato pompa passanti.

Es. BS351 - 95B.

Silenced bellhousing have been developed to diminish the noise of applications. Confronting tests have shown a diminution of noise level of 5 dB (A).

They create an elastic connection between the electrical motor and the pump: thanks to an inserted ring in oilresistant rubber the distribution of rumors due to vibrations and moving mechanical components is diminished noticeably.

Thanks to their flexibility, OMT Group's silenced bell housings can be used in the single piece version as well as in the composite version, employing the same flanges and the same distance rings as used with our traditional bell housings.

N.B.: BS-type silenced bell housings cannot be supplied with passing borings on the pump side (like f.e. BS351-95B).



Tabella / Table 5

Potenza motore 4 poli 1450 giri/1' Motor power 4 poles 1450 revs/min			Lanterna / Bellhousing												
Taglia/Size	kW	HP	Tipo Type	Dimensioni / Dimensions (mm)											
				D1 min	D2	D3	D4	D5	D6	D7	N fori N. of holes	D8	N fori N. of holes	H1	H2
80 ÷ 90	0,55÷1,5	0,75÷2	BS201	60	130	137	130	165	200	12	4	M10	4	138	16
100 ÷ 112	2,2÷4	3÷5,5	BS251	80	180	183	180	215	250	14	4	M12	4	136	21
132	5,5÷9	7,5÷12,5	BS301	80	250	235	230	265	300	14	4	M12	4	170	25
160 ÷ 180	11÷22	15÷30													
200	30	40													
225	37÷45	50÷60	BS451	80	250	350	350	400	450	18*	8*	M16	8	293	27
250 ÷ 280	55÷90	75÷125	BS551	80	250	450	450	500	550	18*	8*	M16	8	303	30
315S	110	150	BS661	80	250	550	550	600	660	22*	8*	M16	8	303	35

*Sede per testa bullone non disponibile - Bolt head counterbore not available

DISTANZIALI / DISTANCE RINGS

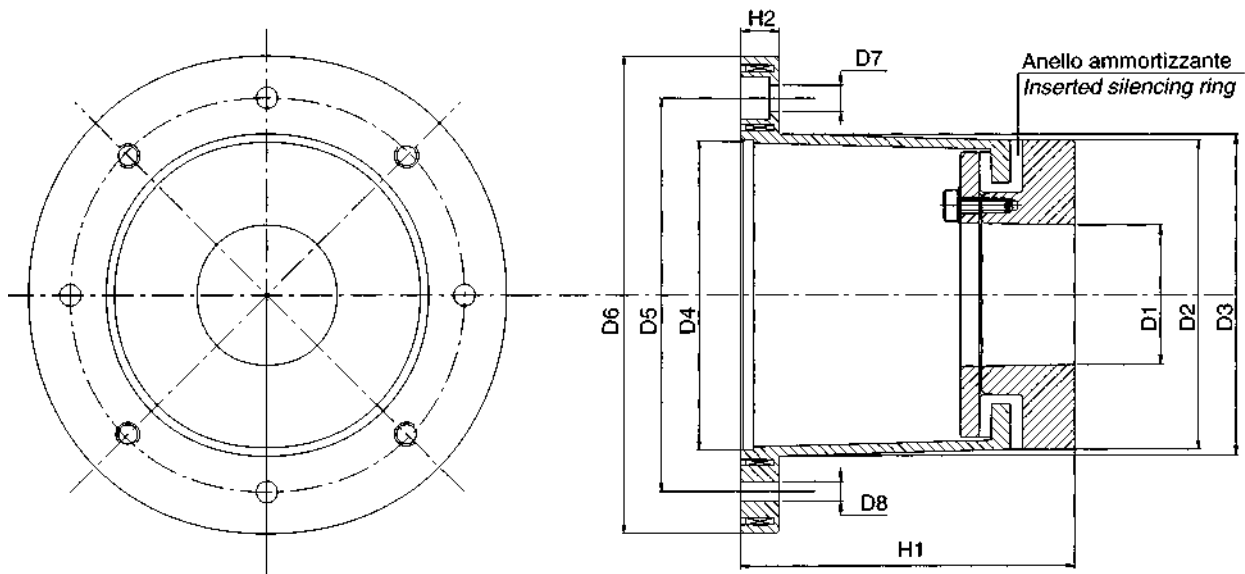
tipo / series **D**



Tabella / Table 6

Lanterna base Base bellhousing	Distanziale / Distance ring				Flange complementari Additional flanges	Codice per l'ordinazione del distanziale singolo Part number of distance ring
	Tipo / Type	Dimensioni / Dimensions (mm)				
		D2	D3	H1	Tipo / Type	
BS351 BS401 BS451	D20	250	237	20	Q4* - T1* - T2A	D - 20
BS551 BS661	D30	250	237	30	Q4* - T1* - T2A	D - 30

N.B.: In caso di necessità è possibile realizzare distanziali più alti di 30 mm con la combinazione di quelli disponibili. Esempio: D40 = D20 + D20
N.B.: Several units can be combined to obtain lengths superior to 30 mm. Example: D40 = D20 + D20

FLANGE / FLANGES

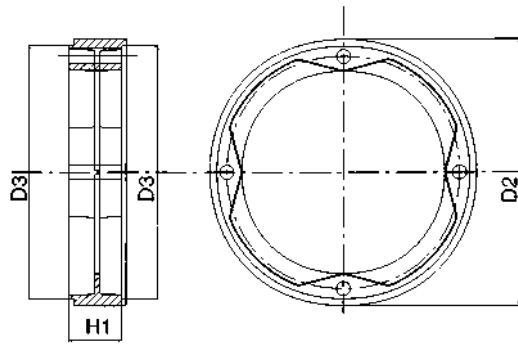
tipo / series **Q**

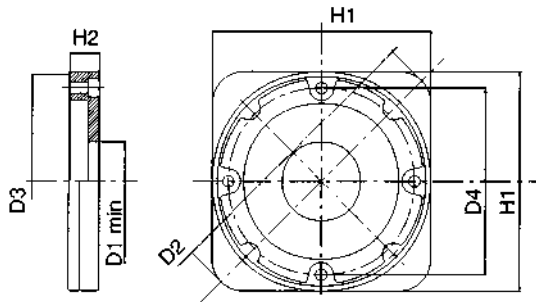

FLANGE / FLANGES

tipo / series **T**



Tabella / Table 7

Lanterna base Base bellhousing	Flange / Flanges							Codice per l'ordinazione della flangia senza lavorazione lato pompa Part number of flanges without machining of pump side
	Tipo / Type	Dimensioni / Dimensions (mm)						
		D1 min	D2	D3	H1	H2	D4	
BS201-BS251 BS301	Q1A	60	170	126	130	17	115	Q1A - 60x
BS251 BS301	Q2A	80	225	171	176	24	150	Q2A - 80x
BS301	Q4M	165	350	237	255	20	218	Q4M - 165x
BS351	T1A	80	247	237	-	65	218	T1A - 80x
BS401	T1D	80	247	237	-	50	218	T1D - 80x
BS451	T1G	80	247	237	-	35	218	T1G - 80x
BS551 BS661	T2A	150	290	237	-	20	218	T2A - 150x
BS301	T3A	80	228	220	-	50	184	T3A - 80x
	T3B	80	228	220	-	45	184	T3B - 80x

LANTERNA / SILENCED BELLHOUSINGS

 tipo / series **BSN**

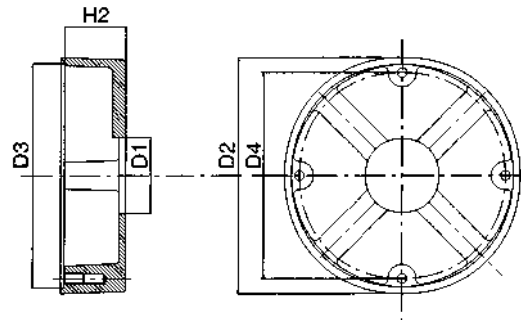
Le nuovissime lanterne insonorizzate serie "BSN" della OMT Group, sono state ideate per ridurre la rumorosità negli impianti oleodinamici.

Tale particolare, permette di collegare in modo elastico il motore elettrico alla pompa oleodinamica e grazie ad un anello in gomma antiolio, interposto tra lanterna base e flangia, viene ridotto notevolmente il propagarsi delle onde sonore dovute alle vibrazioni degli organi meccanici in movimento.

Grazie ad una ricerca approfondita ed all'utilizzo di un nuovo tipo di materiale, siamo riusciti a ridurre l'indice di rumorosità fino a 5 dB contemporaneamente ad una diminuzione dei prezzi.

Grazie alla grande flessibilità, può essere montata nella versione monoblocco oppure nella versione componibile, utilizzando le stesse flange e gli stessi distanziali delle lanterne tradizionali di produzione OMT Group.

N.B.: Nelle lanterne di tipo BSN non è possibile eseguire forature, con fori lato pompa passanti.

Es. BSN351-95B.

The new silenced "BSN" bell-housings have been developed to reduce the noise in the hydraulic systems.

They create an elastic connection between the electrical motor and the pump: thanks to an inserted ring in oilresistant rubber, the distribution of rumors due to vibrations and moving mechanical components, is diminished noticeably.

Thanks to a deep research and to the use of a new material, we have been able to reduce the noise of 5 dB, and at the same time to get a price decrease. Thanks to their flexibility, the "BSN" silenced bell-housings can be used in the single piece version as well as in the composite version, employing the same flanges and the same distance rings as used with our traditional bell-housings.

N.B.: With the "BSN" bell-housings range is possible to get drillings with non- threaded pump holes.

Es. BSN351-95B.



Tabella / Table 5A

Potenza motore 4 poli 1450 giri/1' Motor power 4 poles 1450 revs/min			Lanterna / Bellhousing												
Taglia/Size	kW	HP	Tipo Type	Dimensioni / Dimensions (mm)											
				D1 min	D2	D3	D4	D5	D6	D7	N fori N. of holes	D8	N fori N. of holes	H1	H2
80 ÷ 90	0,55÷1,5	0,75÷2	BSN201	60	130	137	130	165	200	12	4	M10	4	138	16
100 ÷ 112	2,2÷4	3÷5,5	BSN251	80	180	183	180	215	250	14	4	M12	4	136	21
132	5,5÷9	7,5÷12,5	BSN301	80	250	235	230	265	300	14	4	M12	4	193	21
160 ÷ 180	11÷22	15÷30	BSN351	80	250	253	250	300	350	18	4	M16	4	201	25
200	30	40	BSN401	80	250	295	300	350	400	18	4	M16	4	225	25

DISTANZIALI / DISTANCE RINGS

tipo / series **D**

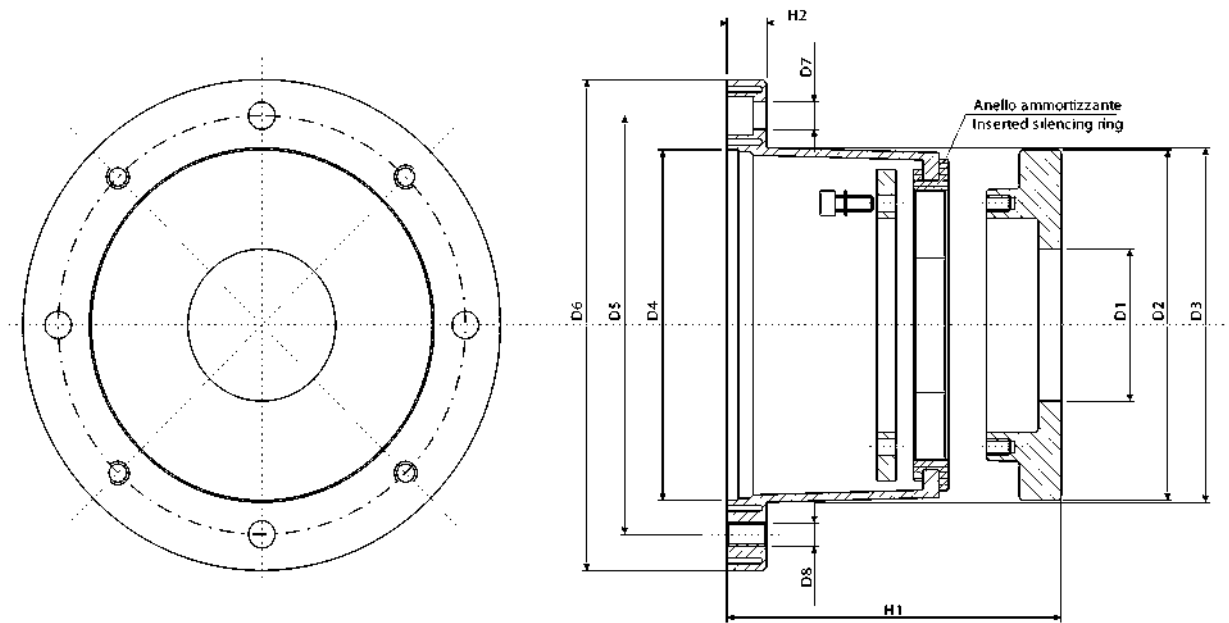

Tabella / Table 6A

Lanterna base Base bellhousing	Distanziale / Distance ring				Flange complementari Additional flanges	Codice per l'ordinazione del distanziale singolo Part number of distance ring
	Tipo / Type	Dimensioni / Dimensions (mm)				
		D2	D3	H1	Tipo / Type	
BSN351 BSN401	D20	250	237	20	Q4* - T1* - T2A	D - 20
	D30	250	237	30	Q4* - T1* - T2A	D - 30

N.B.: In caso di necessità è possibile realizzare distanziali più alti di 60 mm con la combinazione di quelli disponibili. Esempio: D40 = D20 + D20
N.B.: Several units can be combined to obtain lengths superior to 70 mm. Example: D40 = D20 + D20

FLANGE / FLANGES

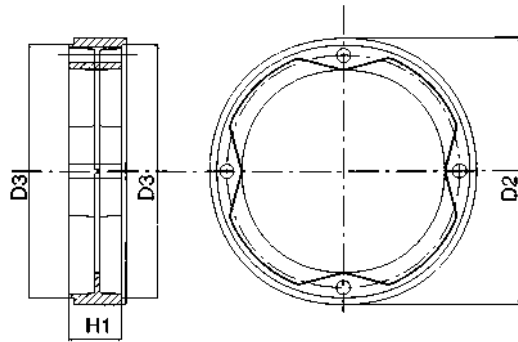
tipo / series **Q**

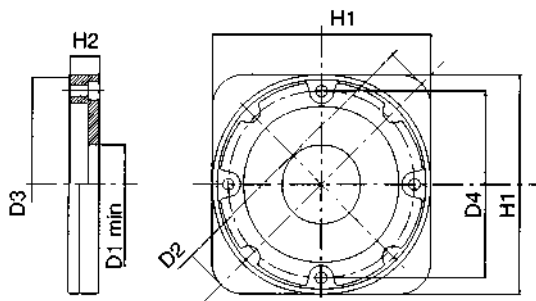

FLANGE / FLANGES

tipo / series **T**



Tabella / Table 7A

Lanterna base Base bellhousing	Tipo / Type	Flange / Flanges						Codice per l'ordinazione della flangia senza lavorazione lato pompa Part number of flanges without machining of pump side
		Dimensioni / Dimensions (mm)						
		D1 min	D2	D3	H1	H2	D4	
BSN201-BSN251 BSN301	Q1A	60	170	126	130	17	115	Q1A - 60x
BSN251 BSN301	Q2A	80	225	171	176	24	150	Q2A - 80x
BSN301 BSN351 BSN401	Q4M	165	350	237	255	20	218	Q4M - 165x
	T1A	80	247	237	-	65	218	T1A - 80x
	T1D	80	247	237	-	50	218	T1D - 80x
	T1G	80	247	237	-	35	218	T1G - 80x
BSN301	T2A	150	290	237	-	20	218	T2A - 150x
	T3A	80	228	220	-	50	184	T3A - 80x
	T3B	80	228	220	-	45	184	T3B - 80x

FORATURE LATO POMPA
BORINGS PUMP SIDE

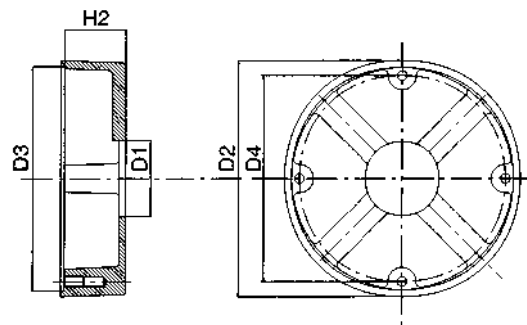
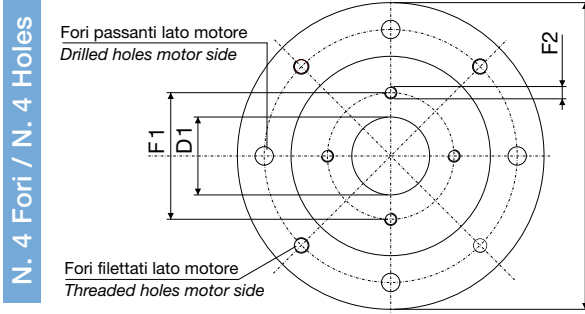

N. 4 Fori / N. 4 Holes
Assi orientati sui fori passanti lato motore da Ø 0 a Ø 400
Axis aligned with passing holes on motor side, from Ø 0 to Ø 400

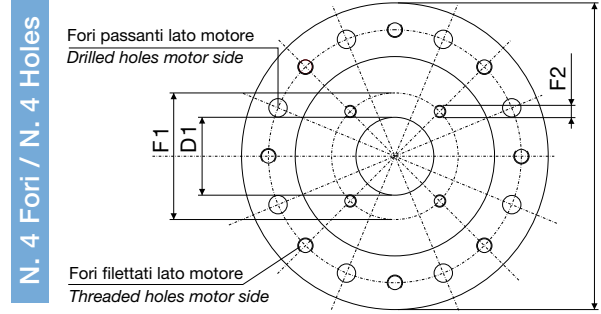

N. 4 Fori / N. 4 Holes
Assi orientati sui fori filettati lato motore da Ø 450 a Ø 660
Axis aligned with threaded holes on motor side, from Ø 450 to Ø 660

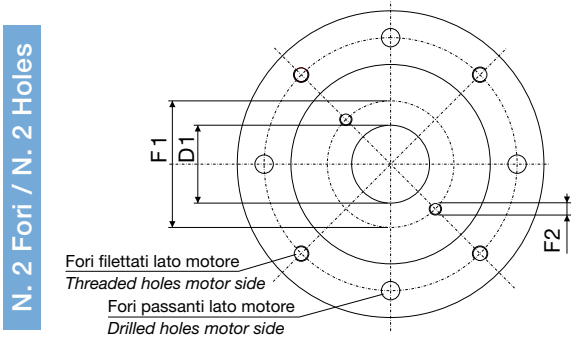

N. 2 Fori / N. 2 Holes
Assi orientati sui fori filettati lato motore
Axis aligned with threaded holes on motor side

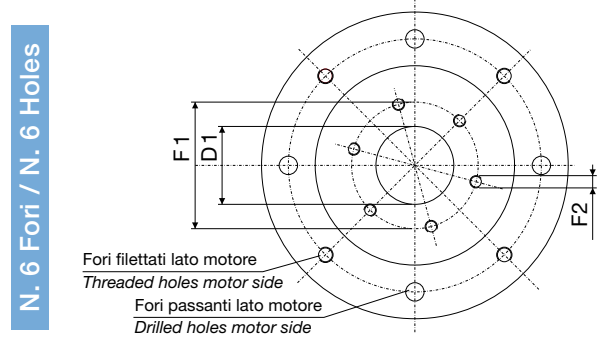

N. 6 Fori / N. 6 Holes
Asse orientato su 1 foro filettato lato motore
Axis aligned with 1 threaded hole on motor side

Tabella / Table 8

Codice Part number	D1	F1	F2	Fori Borings N.	Codice Part number	D1	F1	F2	Fori Borings N.	Codice Part number	D1	F1	F2	Fori Borings N.
45 A	45	85	Ø9	4	825 A	82,55	106	M10	2	112 A	112	140	M12	4
453 A	45,3	72	M8	4	825 B	82,55	162	M10	4	112 B	112	140	M10	2
50 A	50	80	Ø9	6	825 C	82,55	100	Ø10,5	4	112 C	112	140	M12	2
50 B	50	60	M5	4	825 D	82,55	106	Ø10,5	4	115 A	115	180	M12	4
50 C	50	63	M6	4	825 E	82,55	106	M10	4	115 B	115	100	Ø11	4
50 D	50	63	Ø7	4	90 A	90	112	M8	2	116 A	116	160	M14	2
50 E	50	115	M10	2	90 B	90	100	M6	4	120 A	120	145	M10	4
508 A	50,8	82,55	M8	2	90 C	90	113	M10	4	120 B	120	210	M16	4
508 B	50,8	82,55	M8	4	92 A	92	140	M8	4	120 C	120	210	M16	2
508 C	50,8	82,55	M10	2	92 B	92	145	M10	4	125 A	125	160	M12	4
52 A	52	92	Ø9	2	95 A	95	120	M8	4	125 B	125	160	Ø14	4
52 B	52	82	Ø9	4	95 B	95	120	Ø9	4	125 C	125	180	M16	2
60 A	60	74	Ø9	2	95 C	95	127	M10	4	125 D	125	155	M10	4
60 B	60	75	M6	4	952 A	95,2	127	M10	4	125 E	125	160	M12	2
60 C	60	112	M12	2	952 B	95,2	125	Ø11	4	125 F	125	160	Ø18	4
60 D	60	104	M10	2	985 A	98,5	125	Ø11	4	125 G	125	200	M12	4
60 E	60	74	Ø9	4	985 B	98,5	125	M10	4	125 H	125	170	Ø18	4
60 F	60	88	Ø9	4	985 C	98,5	125	M12	4	125 I	125	180	Ø20	4
63 A	63	80	M8	2	100 A	-	-	-	-	125 L	125	170	Ø14	6
63 B	63	80	Ø9	4	100 B	100	125	M10	4	125 M	125	160	M14	4
63 C	63	100	M8	2	100 C	100	125	Ø11	4	125 N	125	200	M16	4
63 D	63	125	M6	4	100 D	100	125	Ø14	4	125 P	125	160	M10	4
63 E	63	160	M8	4	100 E	100	140	M12	2	125 Q	125	160	M16	4
63 F	63	80	M10	2	100 F	100	146	M12	2	125 R	125	180	M16	4
63 G	63	100	M8	4	100 G	100	125	M12	2	127 A	127	181	M16	2
63 H	63	80	M8	4	100 H	100	126	M10	2	127 B	127	162	M12	4
63 I	63	85	M8	4	100 I	100	126	M12	2	127 C	127	162	M14	4
63 L	63	80	Ø10	4	100 L	100	140	M10	2	127 D	127	200	M16	4
63 M	63	80	M10	4	100 M	100	160	M10	4	127 E	127	146	M12	2
63 N	63	106	M10	2	100 N	100	190	Ø16	4	127 F	127	181	M16	8
65 A	65	90	M8	4	100 P	100	126	M8	4	127 G	127	181	M14	2
70 A	70	84	M6	4	100 Q	100	125	M8	4	127 H	127	162	M14	2
80 A	80	100	M8	4	100 R	100	140	M12	4	127 L	127	181	M14	4
80 B	80	100	Ø9	4	100 S	100	120	M8	4	130 A	130	150	M12	4
80 C	80	100	Ø11	4	101 A	101,6	146	M12	2	130 B	130	165	M14	4
80 D	80	106	M10	2	101 B	101,6	127	M12	4	130 C	130	165	M10	4
80 E	80	109	M10	2	101 C	101,6	145	M14	2	130 D	130	150	M10	4
80 F	80	130	M8	4	101 D	101,6	146	M10	2	130 E	130	150	Ø11	8
80 G	80	100	M10	2	101 E	101,6	146	M14	2	135 A	135	160	M10	4
80 H	80	100	M10	4	101 F	101,6	142	Ø13	4	135 B	135	175	M12	4
80 I	80	110	M10	2	101 G	101,6	127	M12	2	140 A	140	180	M12	4
80 L	80	115	M10	2	101 H	101,6	146	M12	4	140 B	140	165	M10	4
80 M	80	103	M8	4	108 A	108	140	M8	3	140 C	140	180	M12	2
80 N	80	112	M10	2	110 A	110	130	M8	4	140 D	140	200	M16	4
80 P	80	113	M12	4	110 B	110	175	M10	4	140 E	-	-	-	-
80 Q	80	100	M12	4	110 C	110	205	Ø15	4	140 F	140	180	M12	3
80 R	80	110	M10	4	110 D	110	130	M10	4	140 G	140	180	M14	4
					110 E	110	145	M12	4					

È indispensabile citare l'esatto codice di ordinazione
The complete and correct part number is needed to process your order

Esempio: **Versione Monoblocco**
Example: **Single piece bellhousing**

TH15 - 100B Normale / Standard
vedi / see tab. 1 vedi / see tab. 8

BS551 - 100B Insonorizzata / Silenced
vedi / see tab. 5 vedi / see tab. 8

Esempio: **Versione Componibile**
Example: **Composite bellhousing**

BASE/BASE FLANGIA/FLANGE
B15 T1A - 100B Normale / Standard
vedi / see tab. 2 vedi / see tab. 4 vedi / see tab. 8

BASE/BASE FLANGIA/FLANGE
BS551 T1A - 100B Insonorizzata / Silenced
vedi / see tab. 5 vedi / see tab. 7 vedi / see tab. 8

Esempio: **Versione Componibile, con distanziale**
Example: **Composite bellhousing, with distance ring**

BASE/BASE DISTANZIALE FLANGIA
DISTANCE RING FLANGE
B15 D20 T1A - 100B Normale / Standard
vedi / see tab. 2 vedi / see tab. 3 vedi / see tab. 4 vedi / see tab. 8

BASE/BASE DISTANZIALE FLANGIA
DISTANCE RING FLANGE
BS551 D20 T1A - 100B Insonorizzata / Silenced
vedi / see tab. 5 vedi / see tab. 6 vedi / see tab. 7 vedi / see tab. 8

TIPOLOGIE SPECIALI DI FORATURE

G

N.B.: Aggiungendo alla fine del codice la lettera G vi è la possibilità di cambiare l'orientamento dei fori lato pompa.

Esempio: **TH4 - 80L - G** i due fori saranno orientati sui fori passanti lato motore.

R

N.B.: Aggiungendo alla fine del codice la lettera R vi è la possibilità di avere il doppio orientamento fori.

Esempio: **TH4 - 80L - R** avrete 4 fori, due orientati sui fori filettati lato motore e due sui fori passanti lato motore.

SPECIAL BORINGS

G

N.B.: Adding "G" at the end of the part number it is possible to change the orientation of the borings on the pump side.

Example: **TH4 - 80L - G** The two borings will be aligned with the passing borings on the motor side.

R

N.B.: Adding "R" at the end of the part number it is possible to require a double orientation of the borings on the pump.

Example: **TH4 - 80L - R** The bellhousing will be supplied borings, two of which aligned with the threaded borings other two with the passing borings on the motor side.



Pompa oleodinamica

I giunti di accoppiamento sono utilizzati quali elementi di collegamento tra motore elettrico a flangia unificata e pompa oleodinamica per la trasmissione del moto. I giunti di questa gamma consentono un assemblaggio ottimale tra motori elettrici a flangia unificata fino a 315 kW.

SEMIGIUNTI serie **ND**
realizzati in alluminio con preforo minimo di fusione (elastici)

SEMIGIUNTI serie **NS**
realizzati in alluminio con mozzo chiuso (elastici)

SEMIGIUNTI serie **NDG**
realizzati in ghisa sferoidale con mozzo chiuso (elastici)

SEMIGIUNTI serie **OMT**
realizzati in acciaio con mozzo sia lavorato che chiuso

I semigiunti vengono ricavati dal chiuso nei seguenti casi:

1. La lunghezza del semigiunto ND non è sufficiente a realizzare l'accoppiamento.
2. Il preforo di fusione è troppo grande rispetto al foro da realizzare per il calettaggio sulla pompa.
3. Il mozzo è troppo piccolo per poter realizzare la foratura per il calettaggio sulla pompa.

Dati indispensabili per la scelta del semigiunto

1. Potenza del motore (tab. motori vedi pag. 25).
2. Caratteristiche dimensionali della pompa oleodinamica.

MATERIALI

Semigiunti serie	
- NS/ND	Lega di alluminio per pressofusione e conchiglia
- NDG	Ghisa sferoidale
- OMT	Acciaio
Inserito elastico per	
- ND	Miscela di acril nitrile butadiene durezza 75 Shore ±5% nera
- NDG 86/108/143	Miscela di acril nitrile butadiene durezza 92 Shore ±5% rossa
- NDG 160/200	Poliuretano 90 Shore ±5% nero

Manicotto per
- **OMT** Poliammide 6.6

Temp. di esercizio -15°C +100°C

COMPATIBILITÀ CON I FLUIDI

Tutte le parti che vengono esposte all'ambiente marino devono essere protette con trattamenti superficiali oppure con vernici adeguate all'impiego e comunque da specificare in fase di ordinazione del materiale all'ufficio commerciale.

APPLICAZIONI SPECIALI

Per tutte le applicazioni che non rientrano nei casi normali specificati in questo catalogo contattare l'ufficio commerciale della OMT Group per un eventuale studio di fattibilità.

Hydraulic pump

The couplings are used to establish a connection between an electrical motor with standard flange and a pump. The bellhousings of this range allow to establish a perfect assembly between electrical motors with standard flange up to 315 kW and the majority of the hydraulic pumps available on the world market.

HALF COUPLINGS series **ND**
in aluminium, with precast minimal boring (elastic type)

HALF COUPLINGS series **NS**
in aluminium, blank (elastic type)

HALF COUPLINGS series **NDG**
in spheroid iron, blank (elastic type)

HALF COUPLINGS series **OMT**
in steel, available blank or with machined front

In the following cases the halfcouplings are machined from blank raw parts:

1. The length of the ND type halfcoupling is not sufficient to realize the required complete coupling
2. The diameter of the precast minimal boring is too big to allow correct fixation on the pump shaft
3. The diameter of the head is too small to allow the realization of the required pump side boring.

Necessary indications for the correct choice of a halfcoupling

1. Power of the motor (tab. motors see pag. 17).
2. Dimensional data of the hydraulic pump.

MATERIALS

Halfcouplings series	
- NS/ND	Alluminium alloy for die-and shell-casting
- NDG	Spheroid cast iron
- OMT	Steel
Rubber spider	
- ND	Acryl-Nitrile-BuNa 75 shore ±5% black
- NDG 86/108/143	Acryl-Nitrile-BuNa 92 shore ±5% red
- NDG 160/200	Polyurethane 90 Shore ±5% black

Polyamid ring
- **OMT** Polyamide 6.6

Working temperature -15°C +100°C

COMPATIBILITY WITH MARINE SURROUNDINGS

On request all our bellhousings can be supplied with specific coating or surface treatment that makes them suitable for use in marine surroundings.

SPECIAL APPLICATIONS

The present leaflet covers only standard applications. Our technical department is equipped to study on request special solutions for particular applications. Please contact our commercial department for further information.

GIUNTI IN ALLUMINIO / ALUMINIUM COUPLINGS

tipo / series **ND**

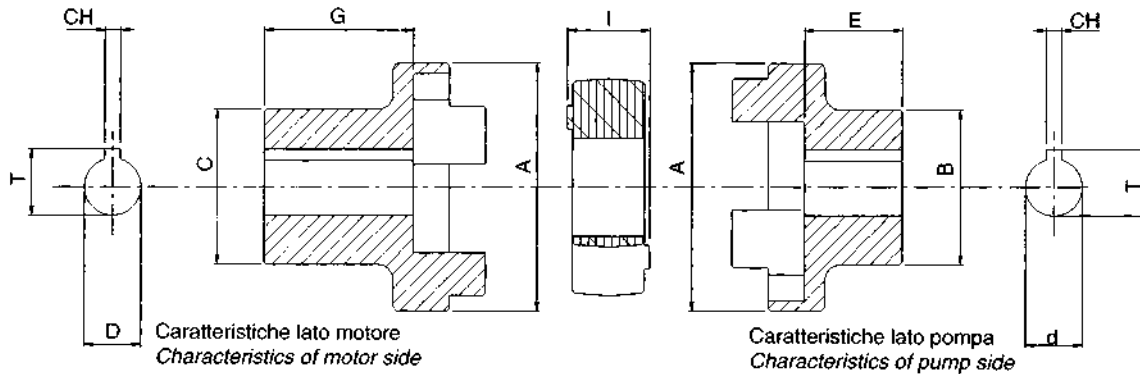

GIUNTI IN ALLUMINIO CHIUSI / BLANK ALUMINIUM COUPLINGS

tipo / series **NS**

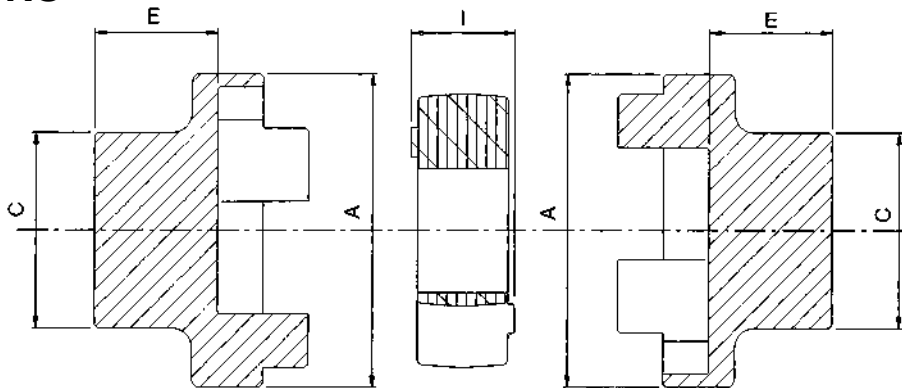

INSERTI ELASTICI / RUBBER SPIDERS

tipo / series **R**

Tabella / Table 11

Taglia giunto Coupling size	Inserto elastico / Rubber spider			
	Tipo Type	Dimensioni (mm) / Dimensions (mm)		
		l	Ø	d albero max
48	R-42	16	19	14
65	R-62	18	29	22
86	R-82	20	31,5	24
108	R-103	24	42	32
143	R-132	29	64	50

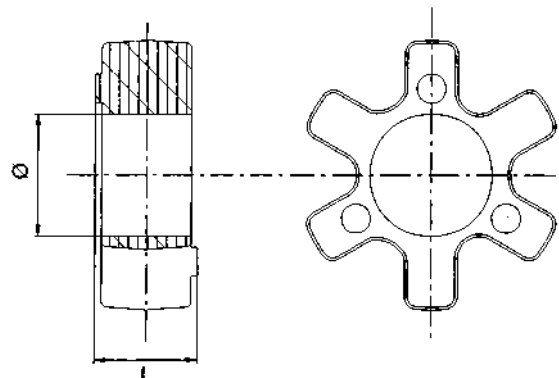

DATI TECNICI / TECHNICAL DATA

Tipo Type	Coppia massima (Nm) Max. torque (Nm)	Potenza max a n° giri/min max. power at revs/min				Disallineamento max Max. misalignment		
		750	1000	1500	3000	Angolare Angular	Max. misalignment	
							Radiale (mm) Radial (mm)	Assiale (mm) Axial (mm)
ND 48	6,86	0,54	0,72	1,1	2,1	2°	0,5	1
ND 65	38,2	3	4	6	12	2°	1	1,6
ND 86	87,3	6,84	9,12	13,7	27,3	2°	1	1,8
ND 108	210	16,5	22	33	65,8	2°	1	2
ND 143	725	57	76	144	228	2°	1	2

Coppie limite in [Nm] dei semigiunti e disallineamenti massimi.

Entrambe le versioni dei giunti hanno le capacità di:

- Sopportare disallineamenti angolari
- Sopportare disallineamenti radiali
- Sopportare disallineamenti assiali

Max. misalignment and torque in Nm supported by OMT Group halfcouplings. Both versions of couplings can partially compensate angular, radial and axial misalignments.

Tabella / Table 12

Potenza motore 4 poli 1450 giri/1' Motor power 4 poles 1450 revs/min			Semigiunto lato motore Halfcoupling motor side					Semigiunto lato condotto / Halfcoupling pump side						Manicotto trascinatore Polyamide ring				Filo granaio Grid screw			
kW	Tg. Size	HP	Codice Part number	Dimensioni / Dimensions (mm)					Codice Part number	Dimensioni / Dimensions (mm)					Codice Part number	A	C		G	M	
				B	E	D	CH	T		B	E (lunghezza) / Dim. "E" (length)			D max							
0,12 ÷ 0,18	63	0,16 ÷ 0,25	OMT1023C02	23	23	11	4	12,8	OMT1 **	23	23	30			14	POL-1	40	40	4	M6	
0,25 ÷ 0,37	71	0,35 ÷ 0,55	OMT1030C07	23	30	14	5	16,3													
0,55 ÷ 0,75	80	0,75 ÷ 1	OMT2040C20	45	40	19	6	21,8	OMT2 **	45	33	40	50		24	POL-2	55	42	4	M6	
1,1 ÷ 1,5	90	1,5 ÷ 2	OMT2050C31	45	50	24	8	27,3													
2,2 ÷ 4	100 ÷ 112	3 ÷ 5,5	OMT3060C36	57	60	28	8	31,3	OMT3 **	57	30	40	60		32	POL-3	70	45	4	M6	
5,5 ÷ 9	132	7,5 ÷ 12,5	OMT4080C47	69	80	38	10	41,3	OMT4 **	69	40	50	55	60	80	38	POL-4	86	48	4	M8
11 ÷ 15	160	15 ÷ 20	OMT5110C51	81	110	42	12	45,3	OMT5 **	81	60	80	110		48	POL-5	102	50	4	M8	
18,5 ÷ 22	180	25 ÷ 30	OMT5110C54	81	110	48	14	51,8													
30	200	40	OMT6110C56	99	110	55	16	59,3	OMT6 **	99	62,5	80	110	140	65	POL-6	150	72	8	M10	
37 ÷ 45	225	50 ÷ 60	OMT6140C57	99	140	60	18	64,4													
55	250	75	OMT6140C58	99	140	65	18	69,4													
75 ÷ 90	280	100 ÷ 125	OMT7140C60	124	140	75	20	79,9	OMT7 **	124	140	90		80	POL-7	180	93	8	M10		
110	315s	150	OMT7140C61	124	140	80	22	85,4													

** Vedi pagina 24 per codifica semigiunto

** See pag. 24 for halfcoupling part number

Tabella / Table 13

Codice Part number	Dimensioni (mm) Dimensions (mm)			Codice Part number	Dimensioni (mm) Dimensions (mm)			Codice Part number	Dimensioni (mm) Dimensions (mm)		
	B	D max	E		B	D max	E		B	D max	E
OMT 1023C	23	14	23	OMT 4040C	69	38	40	OMT 6062C	99	65	62,5
OMT 1030C	23	14	30	OMT 4050C	69	38	50	OMT 6080C	99	65	80
OMT 2033C	45	24	33	OMT 4055C	69	38	55	OMT 6110C	99	65	110
OMT 2040C	45	24	40	OMT 4060C	69	38	60	OMT 6140C	99	65	140
OMT 2050C	45	24	50	OMT 4080C	69	38	80	OMT 7090C	124	80	90
OMT 3030C	46	32	30	OMT 5060C	81	48	60	OMT 7140C	124	80	140
OMT 3040C	57	32	40	OMT 5080C	81	48	80				
OMT 3060C	57	32	50	OMT 5110C	81	48	110				

SEMIGIUNTI IN ACCIAIO / STEEL HALFCOUPLINGS

tipo / series **OMT**

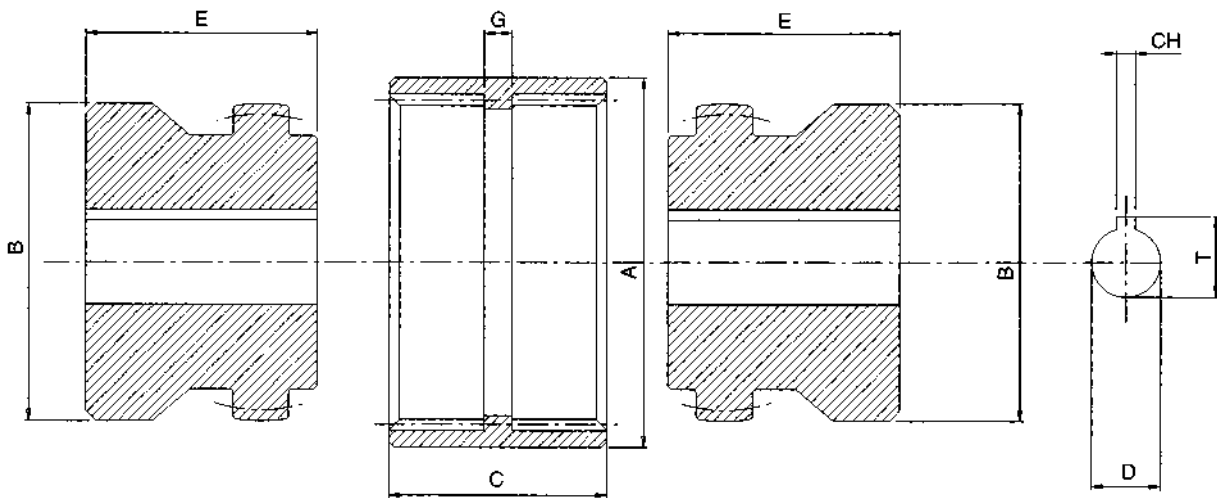

SEMIGIUNTI IN ACCIAIO CHIUSI / BLANK STEEL HALFCOUPLINGS

tipo / series **OMT**

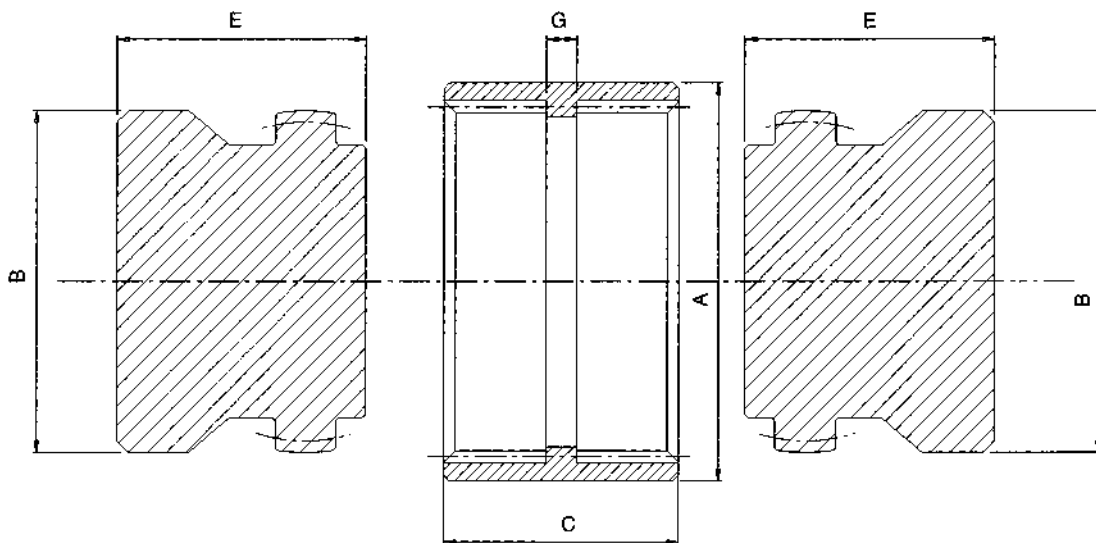

DATI TECNICI / TECHNICAL DATA

Coppie limite in [Nm] dei semigiunti e disallineamenti massimi.

Max. misalignment and torque in Nm supported by OMT Group halfcouplings.

Entrambe le versioni dei giunti hanno le capacità di:

Both versions of couplings can partially compensate angular, radial and axial misalignments.

- Sopportare disallineamenti angolari
- Sopportare disallineamenti radiali
- Sopportare disallineamenti assiali

Taglia Size	Coppia limite Max. torque	Potenza max a n° giri/min / Max. power at revs/min kW				Disallineamento max / Max. misalignment		
	Nm max	750	1000	1500	3000	Angolare Angular	Radiale (mm) Radial (mm)	Assiale (mm) Axial (mm)
OMT1	19,62	1,55	2	3	6,1	2°	0,14	1
OMT2	42,2	3,3	4,41	6,6	13,3	2°	0,5	1
OMT3	112,8	9,1	12,2	17,7	35,4	2°	0,5	1
OMT4	186,4	14	19,5	29,2	58,5	2°	0,5	1
OMT5	269,8	21,2	28,2	42,3	84,5	2°	0,5	1
OMT6	412	32,8	43	64,7	130	2°	0,6	1
OMT7	715,8	56,2	74,9	112,4	224,8	2°	0,6	1

Tabella / Table 14

Potenza motore 4 poli 1450 giri/1' Motor power 4 poles 1450 revs/min			Semigiunto lato motore Motor side halfcoupling					Semigiunto lato pompa Pump side halfcoupling					Inserto elastico Rubber spider		Fono girano Grub screw	
kW	Taglia Size	HP	Dimensioni / Dimensions (mm)					Codice Part number	Dimensioni / Dimensions (mm)					Codice Part number	M	
			A	C	D	G	CH		T	A	B	D max	E max			E min
2,2 ÷ 4	100 ÷ 112	3 ÷ 5,5	NDG86-060C36					NDG86**	81	55	28	60	20	R-82-92	M8	
5,5 ÷ 9	132	7,5 ÷ 12,5	NDG108-080C47					NDG108**	102	74	55	110	30	R-103-92	M8	
11 ÷ 15	160	15 ÷ 20	NDG108-110C51													
18,5 ÷ 22	180	25 ÷ 30	NDG108-110C54													
30	200	40	NDG108-110C56													
37 ÷ 45	225	50 ÷ 60	NDG143-110C57					NDG143**	134	107	65	110	30	R-132-92	M10	
55	250	75	NDG143-110C58G2													
75 ÷ 90	280	100 ÷ 125	NDG160-085C60G2					NDG160**	160	135	75	140	30	R-160-92	M10	
110 ÷ 132	315	150 ÷ 180	NDG160-085C61G2													

** Vedi pagina 24 per codifica semigiunto
** See pag. 24 for halfcoupling part number

Per potenze superiori ai 132 kW contattare l'ufficio commerciale per la realizzazione dell'accoppiamento.
I semigiunti lato pompa possono essere accorciati con passo di 5 mm e non oltre la misura consentita (E min).

For couplings for motors above 132 kW please contact our sales department.
Halfcouplings can be shortened in steps of 5 mm and not beyond the indicated minimum length (E min).

SEMIGIUNTI IN GHISA / CAST IRON HALF COUPLINGS

tipo / series **NDG**

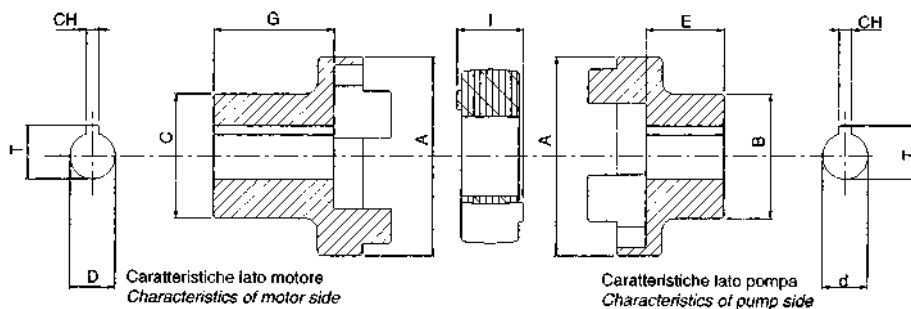

DATI TECNICI TECHNICAL DATA

Codice Part number	Coppia nominale Rated torque (Nm)	Coppia limite Max torque (Nm)
NDG86	90	180
NDG 108	260	520
NDG143	300	600
NDG160	1200	2400

INSERTI ELASTICI / RUBBER SPIDERS

tipo / series **R**

Tabella / Table 15

Tipo di semigiunto Size of coupling	Inserto elastico / Rubber spider			
	Codice Part number	Dimensioni (mm) / Dimensions (mm)		
		I	Ø	D max
NDG86	R-82-92	20	31,5	24
NDG108	R-103-92	24	42	32
NDG143	R-132-92	29	64	50
NDG160	R-160-92	37	80	60
NDG200	R-200-92	41	100	80



Tabella / Table 16

Codice Part number	Tabella / Table "A" DIN 5480		Tabella / Table "B" DIN 5482		Tabella / Table "E" ANS.B.92.1-1970	
	Z	Tipo / Type	Z	Tipo / Type	Z	Spline size
01	14	W20x1,25x14	8	15x12	13	8/16
02	18	W25x1,25x18	9	17x14	15	8/16
03	6	W15x2x6	10	18x15	17	8/16
04	6	W16x2x6	12	20x17	14	12/24
05	7	W17x2x7	13	22x19	16	12/24
06	-	-	14	25x22	17	12/24
07	8	W20x2x8	15	28x25	9	16/32
08	9	W22x2x9	16	30x27	11	16/32
09	11	W25x2x11	17	32x28	12	16/32
10	12	W28x2x12	18	35x31	13	16/32
11	13	W30x2x13	19	38x34	15	16/32
12	14	W30x2x14	20	40x36	21	16/32
13	14	W32x2x14	21	42x38	23	16/32
14	16	W35x2x16	22	45x41	27	16/32
15	17	W37x2x17	23	48x44	40	24/48
16	18	W38x2x18	24	50x45	14	24/48
17	18	W40x2x18	25	52x47	20	24/48
18	20	W42x2x20	26	55x50	21	24/48
19	21	W45x2x21	27	58x53	23	24/48
20	24	W50x2x24	28	60x55	25	24/48
21	26	W55x2x26	29	62x57	26	24/48
22	28	W58x2x28	30	65x60	27	24/48
23	28	W60x2x28	31	68x62	28	24/48
24	31	W65x2x31	32	70x64	29	24/48
25	34	W70x2x34	33	72x66	32	24/48
26	30	W80x2x38	34	75x69	21	32/64
27	-	-	35	78x72	24	32/64
28	-	-	36	80x74	30	32/64
29	-	-	37	82x76	33	32/64
30	-	-	38	85x79	23	40/80
31	-	-	39	88x82	36	48/96
32	-	-	40	90x84	41	48/96
33	-	-	41	92x86	47	48/96
34	-	-	42	95x89	-	-
35	-	-	43	98x92	-	-
36	-	-	44	100x94	-	-
37	-	-	8	32x36**	-	-

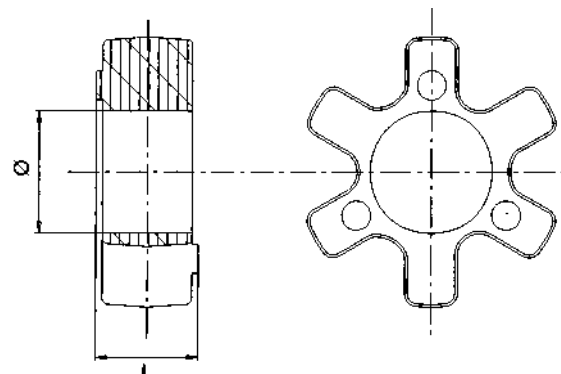

Tabella / Table 18

Codice Part number	Lavorazione per albero condotto Machining of pump side			Secondo la normativa According to standard
	Dimensioni / Dimensions (mm)			
	d	ch	t	
01	10	3	11,4	
02	11	4	12,8	UNEL- MEC 63
03	12	3	13,8	
04	12	4	13,8	
05	13,45	3,17	14,9	
06	14	3	16,3	
07	14	5	16,3	UNEL- MEC 71
08	15	4	17,3	
09	15	5	17,3	
10	15,88	4	17,7	SAE
11	15,88	4,76	18,1	
12	16	4	17,5	
13	16	5	18,3	
14	17	5	19,3	
15	17,46	4,76	19,6	
16	18	5	20,3	
17	18	6	20,8	
18	19	3	20,8	
19	19	5	21,3	
20	19	6	21,8	UNEL- MEC 80
21	19,05	3,17	20,7	
22	19,05	4,76	21,3	SAE A
23	20	5	22,4	
24	20	6	22,8	ISO 80
25	22	5	24,8	
26	22	6	24,8	
27	22,22	4,76	24,8	SAE B
28	22,22	6,35	25	
29	24	6	26,5	
30	24	7	27,3	
31	24	8	27,3	UNEL- MEC 90
32	25	6	28	ISO 100
33	25	7	28,3	ISO 100
34	25	8	28,3	ISO 100
35	25,4	6,35	28,8	ISO 100
36	28	8	31,3	UNEL-MEC 100-112
37	30	8	33,3	
38	30	10	33,3	
39	31,75	6,35	35,1	SAE C
40	31,75	7,94	35,5	
41	31,75	8	35,5	
42	32	8	35,3	
43	32	10	35,3	ISO 125
44	33	10	36,3	
45	34,9	7,94	38,6	SAE
46	35	10	38,3	
47	38	10	41,3	UNEL- MEC 132
48	38,1	9,52	42,5	SAE
49	40	10	43,3	
50	40	12	43,3	ISO 160
51	42	12	45,3	UNEL- MEC 160
52	44,45	11,11	49,4	SAE
53	45	14	48,8	
54	48	14	51,8	UNEL- MEC 180
55	50	14	53,8	ISO 200
56	55	16	59,3	UNEL- MEC 200
57	60	18	64,4	UNEL- MEC 225
58	65	18	69,4	UNEL- MEC 250
59	70	20	74,9	
60	75	20	79,9	UNEL- MEC 280
61	80	22	85,4	UNEL- MEC 315S
62	12,7	3,18	13,8	
63	38,1	7,94	42	
64	9	4	11	
65	11	3	12,8	
66	9	3	11	
67	6	2	7	
68	7	2	8	

97, 98, 99 solo per giunti di tipo in alluminio e ghisa
97, 98, 99 only on cast-iron and aluminium couplings

** DIN 5462

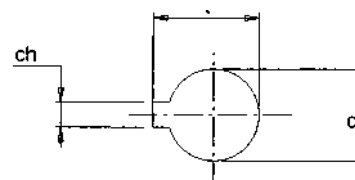
LATO MOTORE

- alluminio
- ghisa
- acciaio

Vedi tabelle in corrispondenza della potenza motore

MOTOR SIDE

- aluminium
- cast iron
- steel

Choose from tables according to required power

TRASCINATORE

- per alluminio R-*** vedi tabella 11 pag. 17
- per ghisa R-***-92 vedi tabella 15 pag. 20
- per acciaio POL-* vedi tabella 12 pag. 18

INSERT/RING

- aluminium R-*** see table 11 pag. 17
- cast iron R-***-92 see table 15 pag. 20
- steel POL-* see table 12 pag. 18

LATO CONDOTTO, ALLUMINIO
ND, NS

sigla identificativa del tipo di semigiunto

- 65H grandezza nominale del semigiunto
- 2 accorciatura "E" del semigiunto
- D senza foro grano (esclude la "C")
- C con foro grano (esclude la "D")
- 24 codice di foratura da eseguire (vedi tab.18)

Esempio: **ND65H2D24 - ND65H2C24**

PUMP SIDE, ALUMINIUM
ND, NS

identifies type of halfcoupling

- 65H nominal size of halfcoupling
- 2 shortening "E" of halfcoupling
- D without grub screw (excludes version "C")
- C with grub screw (excludes version "D")
- 24 reference of required boring (see table 18)

Example: **ND65H2D24 - ND65H2C24**

LATO CONDOTTO, GHISA
NDG

sigla identificativa del tipo di semigiunto

- 86 grandezza nominale del semigiunto
- 060 accorciatura "E" del semigiunto
- D senza foro grano (esclude la "C")
- C con foro grano (esclude la "D")
- 36 codice di foratura da eseguire (vedi tab.18)

Esempio: **NDG86-060D36 - NDG86-060C36**

PUMP SIDE, CAST IRON
NDG

identifies type of halfcoupling

- 86 nominal size of halfcoupling
- 060 shortening "E" of halfcoupling
- D without grub screw (excludes version "C")
- C with grub screw (excludes version "D")
- 36 reference of required boring (see table 18)

Example: **NDG86-060D36 - NDG86-060C36**

LATO CONDOTTO, ACCIAIO
OMT

sigla identificativa del tipo di semigiunto

- 2 grandezza nominale del semigiunto
- 050 accorciatura "E" del semigiunto
- D senza foro grano (esclude la "C")
- C con foro grano (esclude la "D")
- 24 codice di foratura da eseguire (vedi tab.18)

Esempio: **OMT2050D24 - OMT2050C24**

PUMP SIDE, STEEL
OMT

identifies type of halfcoupling

- 2 nominal size of halfcoupling
- 050 shortening "E" of halfcoupling
- D without grub screw (excludes version "C")
- C with grub screw (excludes version "D")
- 24 reference of required boring (see table 18)

Example: **OMT2050D24 - OMT2050C24**

LATO CONDOTTO, PROFILO SCANALATO
OMT, NDG

sigla identificativa del tipo di semigiunto

- 2 grandezza nominale del semigiunto
- 050 accorciatura "E" del semigiunto
- S sigla identificativa per scanalatura
- E tipo di scanalatura (vedi tab.16)
- 07 codice scanalatura da eseguire (vedi tab.16)

Esempio: **OMT2050SE07 - NDG86-045SE10**

PUMP SIDE, SPLINED PROFILE
OMT, NDG

identifies type of halfcoupling

- 2 nominal size of halfcoupling
- 050 shortening "E" of halfcoupling
- S indicated splined profile
- E type of splining (see table 16)
- 07 reference of required splining (see table 16)

Example: **OMT2050SE07 - NDG86-045SE10**

FLANGIA / FLANGE

tipo / series **B3 - B5**

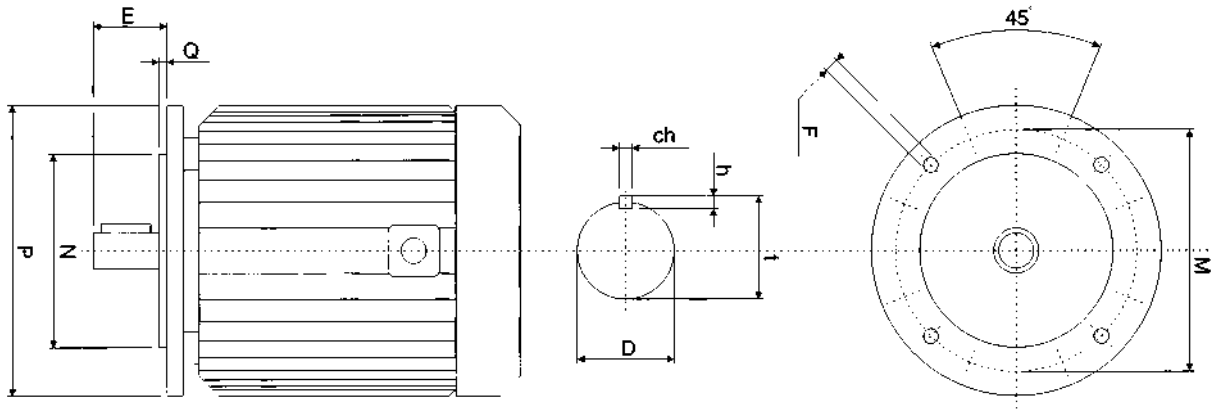

Dati tecnici motori / Technical data of motors																		
Taglia Size	2 poli / 2 poles		4 poli / 4 poles		6 poli / 6 poles		8 poli / 8 poles		Dimensioni flangia / Dimensions flange					Dimensioni albero / Dimensions of shaft				
	2900 giri/min - revs/min		1450 giri/min - revs/min		960 giri/min - revs/min		720 giri/min - revs/min		P	M	N	Q	F	D	E	ch	b	t
	kW	HP	kW	HP	kW	HP	kW	HP										
80	0,75	1	0,55	0,75	0,37	0,5	0,18	0,25	200	165	130	3,5	11,5	19	40	6	6	21,8
	1,1	1,5	0,75	1	0,55	0,75	0,25	0,35										
90	1,5	2	1,1	1,5	0,75	1	0,37	0,5	200	165	130	3,5	11,5	24	50	8	7	27,3
	2,2	3	1,5	2	1,1	1,5	0,55	0,75										
100	3	4	2,2	3	1,5	2	0,75	1	250	215	180	4	14	28	60	8	7	31,3
112	4	5,5	4	5,5	2,2	3	1,5	2	250	215	180	4	14	28	60	8	7	31,3
132	5,5	7,5	5,5	7,5	3	4	2,2	3	300	265	230	4	14	38	80	10	8	41,3
	9	12,5	9	12,5	5,5	7,5	3	4										
160	11	15	11	15	7,5	10	4	5,5	350	300	250	5	18	42	110	12	8	45,3
	18,5	25	15	20	11	15	7,5	10										
180	22	30	18,5	25	15	20	11	15	350	300	250	5	18	48	110	14	9	51,8
200	30	40	30	40	18,5	25	15	20	400	350	300	5	18	55	110	16	10	59,3
	37	50			22	30												
225	45	60							450	400	350	5	18	55	110	16	10	59,3
225			37	50	30	40	18,5	25	450	400	350	5	18	60	140	18	11	64,4
250	55	75							550	500	450	5	18	60	140	18	11	64,4
250			55	75	37	50	30	40	550	500	450	5	18	65	140	18	11	69,4
280	75	100							550	500	450	5	18	65	140	18	11	69,4
	90	125																
280			75	100	45	60	37	50	550	500	450	5	18	75	140	20	12	79,9
			90	125	55	75	45	60										
315 S	110	150							660	600	550	6	22	65	140	18	11	69,4
315 S			110	150	75	100	55	75	660	600	550	6	22	80	170	22	14	85,4

ACCOPIAMENTI TRA MOTORI ELETTRICI A FLANGIA UNIFICATA B3 - B5 - B14 POMPE OLEODINAMICHE AD INGRANAGGI

CONNECTIONS BETWEEN ELECTRICAL MOTORS WITH STANDARD B3 - B5 - B14 FLANGE AND HYDRAULIC GEAR PUMPS

Nelle pagine che seguiranno sono riportati tutti gli accoppiamenti standard che la OMT Group realizza per l'assemblaggio di motori elettrici e pompe ad ingranaggi fino ad una potenza di 45 kW.

On the following pages we list the complete program of standard couplings for use with electrical motors up to 45 kW and hydraulic gear pumps, as manufactured by OMT Group.

DATI:

Potenza del motore

Grandezza della pompa da scegliere sulle tabelle a seconda della flangiatura della pompa stessa e del tipo di albero

DATA:

Motor power
Size of pump

to be chosen from the following table according to the flange type and the shaft of the pump.

Si possono trovare i codici della lanterna e dei semi-giunti necessari all'accoppiamento ideale e le relative dimensioni di ingombro.

In the following table you can find the part numbers as well as the dimensions of the bellhousings and couplings needed to realize the connection between pump and motor.



Tabella / Table 19 Rif. pompa / Pump code

Taglia / Size	Tipo flangia / Type of flange	Rif. pompa Pump code	Pompa / Pump				
			Dimensioni / Dimensions (mm)				
			E	L	M	N	O
0,5	Standard	05M/05GT	22	25,5	66	-	M6
1	Standard	U 1 P	25,4	26,2	72	52	M6
1	Marzocchi	1C/1M	30	24,5	73	56	M6
2	Standard	2	36,5	32,5	96	71,5	M8
3	Turolla (Sauer) Dowty	T250	50,8	43	128	98,5	M8
3	Standard	3 U	50,8	42	128	98,5	M10
3	Marzocchi - HPI	M 3	50,8	43	128	98,5	M10
3	Turolla (Sauer)	T 3	50,8	45	137	98,5	M10
3,5	Marzocchi	35 M	60	48,2	148	127	M12
3,5	Standard	35 U	60,3	49,5	149,5	114,3	M10
4	Marzocchi - Turolla (Sauer)	4M/4T	63,5	65	196	142,8	M12
4	Standard	4 U	63,5	64,3	188	143	M12
GR. BOSCH	Bosch tipo ZBR	ZB	32	10,3	40	40	M8
GR. BOSCH	Bosch tipo ZFR - S	ZF	80	34,5	100	72	M8
GR. BOSCH	Bosch tipo ZGR - S	ZG	105	48	145	102	M10

Applicazioni speciali

Per tutte le applicazioni che non rientrano nei casi normali specificati in questi cataloghi contattare l'ufficio commerciale della OMT Group per un eventuale studio di fattibilità.

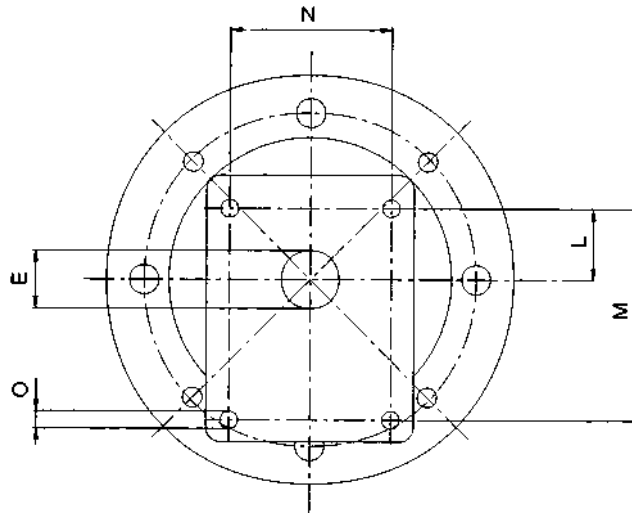
Special applications

For all applications not foreseen by this catalogue please contact our commercial department. We will be pleased to verify the possibility to realize a special connection.

TIPOLOGIA DELLE LANTERNE DISPONIBILI / TYPE OF AVAILABLE BELLHOUSINGS

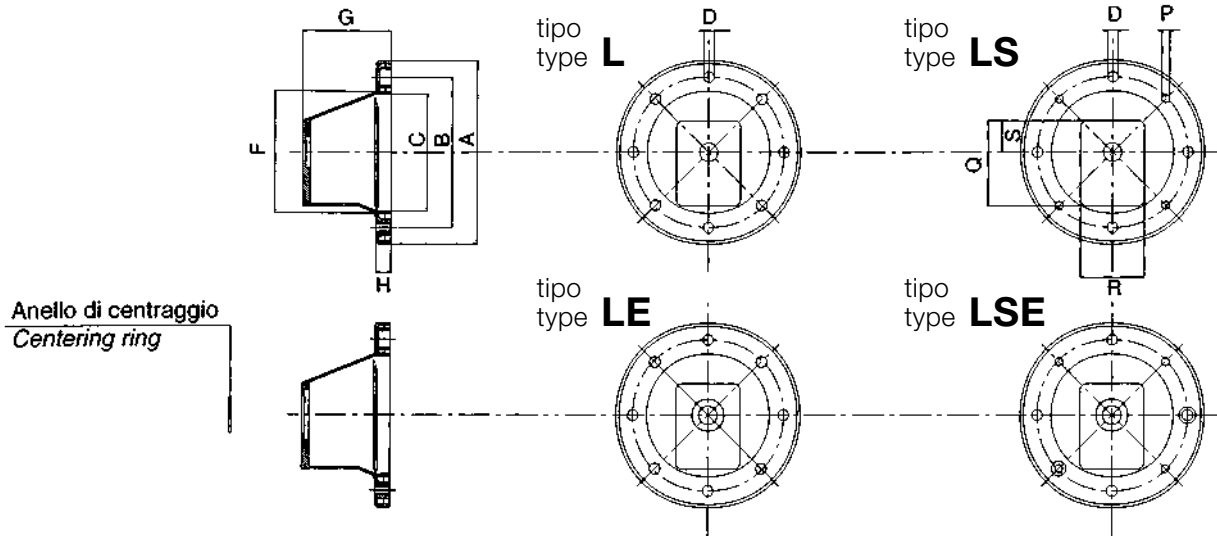

- L** 8 fori passanti lato motore
8 passing holes on motor side
- LS** 4 fori passanti + 4 fori filettati lato motore
4 passing holes + 4 threaded holes on motor side

- LE** 8 fori passanti lato motore e anello di centraggio in lamiera per estrazione del giunto
8 passing holes on motor side + sheet metal centering ring for the extraction of the coupling.
- LSE** 4 fori passanti + 4 fori filettati lato motore e anello di centraggio in lamiera per estrazione del giunto
4 passing holes + 4 threaded holes on motor side + sheet metal centering ring for the extraction of the coupling.

Tabella / Table 20

Potenza motore 4 poli 1450 giri/1'			Semigiunto lato motore Motor side halfcoupling						
Motor power 4 poles 1450 revs/min			Codice Part number	Dimensioni / Dimensions (mm)					
kW	Taglia Size	HP		A	C	G	D	CH	T
0,12	63	0,16	ND 48A	48	30	19	11	4	12,8
0,18		0,25							
0,25	71	0,35	ND 48B	48	30	29	14	5	16,3
0,37		0,55							
0,55	80	0,75	ND 48C	48	38	54	19	6	21,8
0,75		1							
1,1	90	1,5	ND 48D	48	38	54	24	8	27,3
1,5		2							
0,55	80	0,75	ND 65A	65	42	47,5	19	6	21,8
0,75		1							
1,1	90	1,5	ND 65B	65	48	47,5	24	8	27,3
1,5		2							
2,2	100	3	ND 65C	65	53	57,5	28	8	31,3
4		5,5							
2,2	100	3	ND 86A	86	55	60	28	8	31,3
4		5,5							
5,5	132	7,5	ND 86B	86	73	88	38	10	41,3
9		12,5							
5,5	132	7,5	ND 108A	108	73	77	38	10	41,3
9		12,5							
11	160	15	ND 108B	108	84	110	42	12	45,3
15		20							
18,5	180	25	ND 108C	108	100	110	48	14	51,8
22		30							
30	200	40	ND 108D	108	100	110	55	16	59,3
30	200	40	ND 143B	143	106	110	55	16	59,3
37	225	50	ND 143C	143	137	140	60	18	64,4
45		60							



Tabella / Table 21

Rif. pompa Pump code	Dimensioni (mm) lato pompa / Dimensions (mm) pump side				
	Tipo / Type	d	Ch	t	L
05 M	cilindrico / cylindric	6	2	7	10
05 GT	cilindrico / cylindric	7	2	8	10
1 C	cilindrico / cylindric	12	3	13,3	13,5
U1P	con 1:8 / taper 1:8	9,7	2,4	10,5	15
1M	con 1:8 / taper 1:8	13,9	3	15,5	18,5
2 (CA)	con 1:8 / taper 1:8	17,2	3,2	18,5	23
2 (U)	con 1:8 / taper 1:8	17,2	4	18,5	23
3U	con 1:8 / taper 1:8	22,2	4	23,6	28
35 (U)	con 1:8 / taper 1:8	25,6	4,76	27,8	35
35 (M)	con 1:8 / taper 1:8	25,6	5	27,8	35
4 (U)	con 1:8 / taper 1:8	33,3	6,35	35,5	45
4 (M/T)	con 1:8 / taper 1:8	33,3	7	35,5	45
ZB	con 1:5 / taper 1:5	9,8	2	10,2	12
ZF	con 1:5 / taper 1:5	16,9	3	17,7	19
ZG	con 1:5 / taper 1:5	25,2	5	26,3	29

MOTORI FLANGIA B3-B5 / MOTORS WITH FLANGE B3-B5

Motore 4 poli 1450 giri/1' Motor power 4 p. 1450 revs/min		Rif. pompa Pump code	Lanterna Bellhousing				Dimensione lanterna (mm) Dimensions of bellhousing (mm)										Giunto completo serie ND Complete coupling ND series		Semigiunto motore Halfcoupling motor side	Inserito elastico Rubber spider	Semigiunto pompa Halfcoupling pump side	Anelli di centraggio Centering ring	Piedino Foot flange	Anello Amm. Suitable damping ring												
kW	Taglia Size	HP	LE	LSE	L	LS	A	B	C	D	F	G	H	P	Q	R	S	Codice Part number	H	Codice Part number	Codice Part num.	I	Codice Part number	-	-	-	-	-								
0,12 ÷ 0,18	63	0,16 ÷ 0,25	05 M	-	-	1401	140	140	115	95	10	100	60	11	M8	90	69	34	ND 01	54	ND 48A	R-42	16	ND 48P05M	-	-	-	-	-	-	-	-	-			
			05 GT	-	-	1401	140	140	115	95	10	100	60	11	M8	90	69	34	ND 02	54	ND 48A	R-42	16	ND 48P05GT	-	-	-	-	-	-	-	-	-			
			U 1 P	1402	141	1402	141	140	140	115	95	10	100	60	11	M8	90	69	34	ND 03	52	ND 48A	R-42	16	ND 48PU1P	RC1-254	-	-	-	-	-	-	-	-	-	
			1 C	1403	142	1403	142	140	140	115	95	10	100	60	11	M8	90	69	34	ND 04	52	ND 48A	R-42	16	ND 48P1C	RC1-30	-	-	-	-	-	-	-	-	-	
			1 M	1403	142	1403	142	140	140	115	95	10	100	60	11	M8	90	69	34	ND 05	52	ND 48A	R-42	16	ND 48P1M	RC1-30	-	-	-	-	-	-	-	-	-	
			ZB	-	-	LB18	LBS18	140	140	115	95	10	100	60	11	M8	90	69	34	ND 198	52	ND 48A	R-42	16	ND 48PZB	-	-	-	-	-	-	-	-	-	-	-
			ZF	-	-	-	-	-	-	-	-	-	-	-	-	-	-	-	-	-	-	-	-	-	-	-	-	-	-	-	-	-	-	-	-	
0,25 ÷ 0,37	71	0,35 ÷ 0,55	05 M	-	-	1601	160	160	130	110	10	110	70	14	M8	90	69	34	ND 1	64	ND 48B	R-42	16	ND 48P05M	-	-	-	-	-	-	-	-	-	-		
			05 GT	-	-	1601	160	160	130	110	10	110	70	14	M8	90	69	34	ND 1A	64	ND 48B	R-42	16	ND 48P05GT	-	-	-	-	-	-	-	-	-	-	-	
			U 1 P	1602	161	1602	161	160	160	130	110	10	110	70	14	M8	90	69	34	ND 2	62	ND 48B	R-42	16	ND 48PU1P	RC1-254	-	-	-	-	-	-	-	-	-	-
			1 C	1603	162	1603	162	160	160	130	110	10	110	70	14	M8	90	69	34	ND 3	62	ND 48B	R-42	16	ND 48P1C	RC1-30	-	-	-	-	-	-	-	-	-	-
			1 M	1603	162	1603	162	160	160	130	110	10	110	70	14	M8	90	69	34	ND 3A	62	ND 48B	R-42	16	ND 48P1M	RC1-30	-	-	-	-	-	-	-	-	-	-
			ZB	-	-	LB19	LBS19	160	160	130	110	10	110	70	14	M8	90	69	34	ND 199	62	ND 48B	R-42	16	ND 48PZB	-	-	-	-	-	-	-	-	-	-	-
			ZF	-	-	-	-	-	-	-	-	-	-	-	-	-	-	-	-	-	-	-	-	-	-	-	-	-	-	-	-	-	-	-		
0,55 ÷ 0,75	80	0,75 ÷ 1	05 M	-	-	2101	210	200	165	130	12	135	87	15	M10	90	69	34	ND 4B	81	ND 48CG45	R-42	16	ND 48P05M	-	-	-	-	-	-	-	-	-	-		
			05 GT	-	-	2101	210	200	165	130	12	135	87	15	M10	90	69	34	ND 4C	81	ND 48CG45	R-42	16	ND 48P05GT	-	-	-	-	-	-	-	-	-	-	-	
			U 1 P	2102	211	2102	211	200	165	130	12	135	87	15	M10	90	69	34	ND 5A	78	ND 48CG45	R-42	16	ND 48PU1P	RC1-254	-	-	-	-	-	-	-	-	-	-	-
			1 C	2103	212	2103	212	200	165	130	12	135	87	15	M10	90	69	34	ND 6B	78	ND 48CG45	R-42	16	ND 48P1C	RC1-30	-	-	-	-	-	-	-	-	-	-	-
			1 M	2103	212	2103	212	200	165	130	12	135	87	15	M10	90	69	34	ND 6C	78	ND 48CG45	R-42	16	ND 48P1M	RC1-30	-	-	-	-	-	-	-	-	-	-	
			ZB	-	-	LB28	LBS28	200	165	130	12	135	87	15	M10	90	69	34	ND 300	78	ND 48CG45	R-42	16	ND 48PZB	-	-	-	-	-	-	-	-	-	-	-	
			ZF	-	-	-	-	-	-	-	-	-	-	-	-	-	-	-	-	-	-	-	-	-	-	-	-	-	-	-	-	-	-	-		
			05 M	-	-	2001	200	200	165	130	12	135	95	15	M10	90	69	34	ND 4	89	ND 48C	R-42	16	ND 48P05M	-	-	-	-	-	-	-	-	-	-	-	
			05 GT	-	-	2001	200	200	165	130	12	135	95	15	M10	90	69	34	ND 4A	89	ND 48C	R-42	16	ND 48P05GT	-	-	-	-	-	-	-	-	-	-	-	
			U 1 P	2002	201	2002	201	200	165	130	12	135	95	15	M10	90	69	34	ND 5	87	ND 48C	R-42	16	ND 48PU1P	RC1-254	-	-	-	-	-	-	-	-	-	-	
			1 C	2003	202	2003	202	200	165	130	12	135	95	15	M10	90	69	34	ND 6	87	ND 48C	R-42	16	ND 48P1C	RC1-30	-	-	-	-	-	-	-	-	-	-	
			1 M	2003	202	2003	202	200	165	130	12	135	95	15	M10	90	69	34	ND 6A	87	ND 48C	R-42	16	ND 48P1M	RC1-30	-	-	-	-	-	-	-	-	-	-	
			ZB	-	-	LB20	LBS20	200	165	130	12	135	95	15	M10	90	69	34	ND 200	87	ND 48C	R-42	16	ND 48PZB	-	-	-	-	-	-	-	-	-	-		
			ZF	-	-	LB21	LBS21	200	165	130	12	135	95	15	M10	118	86	43	ND 7	87	ND 65A	R-62	18	ND 65P2	RC1-365	-	-	-	-	-	-	-	-	-		
			T 250	2005	205	-	-	200	165	130	12	135	126	16	M10	180	158	65	ND 50A	116	ND 86HD20	R-82	20	ND 65PZF	RC2-508	-	-	-	-	-	-	-	-	-		
			3 U	2006	206	-	-	200	165	130	12	135	126	16	M10	180	158	65	ND 50A	116	ND 86HD20	R-82	20	ND 86H3U	RC2-508	-	-	-	-	-	-	-	-	-		
			M 3	2007	207	-	-	200	165	130	12	135	126	16	M10	180	158	65	ND 50A	116	ND 86HD20	R-82	20	ND 86H3U	RC2-508	-	-	-	-	-	-	-	-	-		
			T 3	2008	208	-	-	200	165	130	12	135	126	16	M10	180	158	65	ND 50A	116	ND 86HD20	R-82	20	ND 86H3U	RC2-508	-	-	-	-	-	-	-	-	-		
			35 M	2009	209	-	-	200	165	130	12	135	126	16	M10	180	158	65	ND 50B	116	ND 86HD20	R-82	20	ND 86H35	RC2-60	-	-	-	-	-	-	-	-	-		
			35 G	2010	213	-	-	200	165	130	12	135	126	16	M10	180	158	65	ND 50B	116	ND 86HD20	R-82	20	ND 86H35	RC2-603	-	-	-	-	-	-	-	-	-		
35 U	2010	213	-	-	200	165	130	12	135	126	16	M10	180	158	65	ND 50B	116	ND 86HD20	R-82	20	ND 86H35	RC2-603	-	-	-	-	-	-	-	-	-					
ZG	-	-	2011	214	200	165	130	12	135	126	16	M10	180	158	65	ND 50D	116	ND 86HD20	R-82	20	ND 86HZG	-	-	-	-	-	-	-	-	-	-					
1,1 ÷ 1,5	90	1,5 ÷ 2	U 1 P	2002	201	2002	201	200	165	130	12	135	95	15	M10	90	69	34	ND 70A	87	ND 48D	R-42	16	ND 48PU1P	RC1-254	-	-	-	-	-	-	-				
			1 C	2003	202	2003	202	200	165	130	12	135	95	15	M10	90	69	34	ND 70B	87	ND 48D	R-42	16	ND 48P1C	RC1-30	-	-	-	-	-	-	-	-			
			1 M	2003	202	2003	202	200	165	130	12	135	95	15	M10	90	69	34	ND 70C	87	ND 48D	R-42	16	ND 48P1M	RC1-30	-	-	-	-	-	-	-	-	-		
			ZB	-	-	LB20	LBS20	200	165	130	12	135	95	15	M10	90	69	34	ND 70D	87	ND 48D	R-42	16	ND 48PZB	-	-	-	-	-	-	-	-	-			
			U 1 P	2002	201	2002	201	200	165	130	12	135	95	15	M10	90	69	34	ND 8	87	ND 65B	R-62	18	ND 65PU1P	RC1-254	-	-	-	-	-	-	-	-			
			1 C	2003	202	2003	202	200	165	130	12	135	95	15	M10	90	69	34	ND 9	87	ND 65B	R-62	18	ND 65P1C	RC1-30	-	-	-	-	-	-	-	-			
			1 M	2003	202	2003	202	200	165	130	12	135	95	15	M10	90	69	34	ND 9A	87	ND 65B	R-62	18	ND 65P1M	RC1-30	-	-	-	-	-	-	-	-			
			ZB	-	-	LB20	LBS20	200	165	130	12	135	95	15	M10	90	69	34	ND 201	87	ND 65															

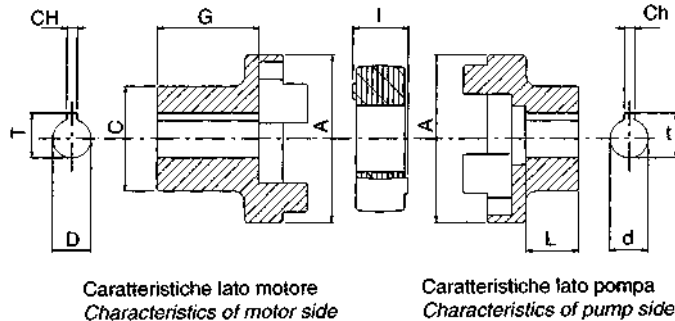
MOTORI FLANGIA B3-B5 / MOTORS WITH FLANGE B3-B5

kW	Taglia Size	HP	Motore 4 poli 1450 giri/1' Motor power 4 p. 1450 revs/min	Rif. pompa Pump code	Lanterna Bellhousing				Dimensione lanterna (mm) Dimensions of bellhousing (mm)																Giunto completo serie ND Complete coupling ND series		Semigiunto Pompa Halfcoupling pump side		Inserto elastico Rubber spider		Semigiunto pompa Halfcoupling pump side		Piedino Foot flange	Anello Amm. Suitable damping ring
					LE	LSE	L	LS	A	B	C	D	F	G	H	P	Q	R	S	Codice Part number	H	Codice Part number	I	Codice Part number	I	Codice Part number								
0,12 ± 0,18	63	0,16 ± 0,25	05 M	-	-	1401	140	140	140	115	95	10	100	60	11	M8	90	69	34	AGN 01	50	OMT 1023C02	POL-1	4	OMT 1023M05	P - 160								
			05 GT	-	-	1401	140	140	140	115	95	10	100	60	11	M8	90	69	34	AGN 02	50	OMT 1023C02	POL-1	4	OMT 1023G05									
			U 1 P	1402	141	1402	141	140	115	95	10	100	60	11	M8	90	69	34	AGN 03	50	OMT 1023C02	POL-1	4	OMT 1023U1P										
			1 C	1403	142	1403	142	140	115	95	10	100	60	11	M8	90	69	34	AGN 04	50	OMT 1023C02	POL-1	4	OMT 1023C1										
			1 M	1403	142	1403	142	140	115	95	10	100	60	11	M8	90	69	34	AGN 05	50	OMT 1023C02	POL-1	4	OMT 1023M1										
			ZB	-	-	LB18	LBS18	140	115	95	10	100	60	11	M8	90	69	34	AGN 198	50	OMT 1023C02	POL-1	4	OMT 1023ZB										
0,25 ± 0,37	71	0,35 ± 0,55	05 M	-	-	1601	160	160	160	130	110	10	110	70	14	M8	90	69	34	AGN 1	57	OMT 1030C07	POL-1	4	OMT 1023M05	P - 160								
			05 GT	-	-	1601	160	160	160	130	110	10	110	70	14	M8	90	69	34	AGN 1A	57	OMT 1030C07	POL-1	4	OMT 1023G05									
			U 1 P	1602	161	1602	161	160	130	110	10	110	70	14	M8	90	69	34	AGN 2	57	OMT 1030C07	POL-1	4	OMT 1023U1P										
			1 C	1603	162	1603	162	160	130	110	10	110	70	14	M8	90	69	34	AGN 3	57	OMT 1030C07	POL-1	4	OMT 1023C1										
			1 M	1603	162	1603	162	160	130	110	10	110	70	14	M8	90	69	34	AGN 3A	57	OMT 1030C07	POL-1	4	OMT 1023M1										
			ZB	-	-	LB19	LBS19	160	130	110	10	110	70	14	M8	90	69	34	AGN 199	57	OMT 1030C07	POL-1	4	OMT 1023ZB										
0,55 ± 0,75	80	0,75 ± 1	05 M	-	-	2101	210	210	200	165	130	12	135	87	15	M10	90	69	34	AGN 4	70	OMT 2033C20	POL-2	4	OMT 2033M05	P - 200 A - 200								
			05 GT	-	-	2101	210	210	200	165	130	12	135	87	15	M10	90	69	34	AGN 4A	70	OMT 2033C20	POL-2	4	OMT 2033G05									
			U 1 P	2102	211	2102	211	200	165	130	12	135	87	15	M10	90	69	34	AGN 5	70	OMT 2033C20	POL-2	4	OMT 2033U1P										
			1 C	2103	212	2103	212	200	165	130	12	135	87	15	M10	90	69	34	AGN 6	70	OMT 2033C20	POL-2	4	OMT 2033C1										
			1 M	2103	212	2103	212	200	165	130	12	135	87	15	M10	90	69	34	AGN 6A	70	OMT 2033C20	POL-2	4	OMT 2033M1										
			ZB	-	-	LB28	LBS28	200	165	130	12	135	87	15	M10	90	69	34	AGN 200	70	OMT 2033C20	POL-2	4	OMT 2033ZB										
			05 M	-	-	2001	200	200	165	130	12	135	95	15	M10	90	69	34	AGN 4	70	OMT 2033C20	POL-2	4	OMT 2033M05										
			05 GT	-	-	2001	200	200	165	130	12	135	95	15	M10	90	69	34	AGN 4A	70	OMT 2033C20	POL-2	4	OMT 2033G05										
			U 1 P	2002	201	2002	201	200	165	130	12	135	95	15	M10	90	69	34	AGN 5	70	OMT 2033C20	POL-2	4	OMT 2033U1P										
			1 C	2003	202	2003	202	200	165	130	12	135	95	15	M10	90	69	34	AGN 6	70	OMT 2033C20	POL-2	4	OMT 2033C1										
			1 M	2003	202	2003	202	200	165	130	12	135	95	15	M10	90	69	34	AGN 6A	70	OMT 2033C20	POL-2	4	OMT 2033M1										
			ZB	-	-	LB20	LBS20	200	165	130	12	135	95	15	M10	90	69	34	AGN 200	70	OMT 2033C20	POL-2	4	OMT 2033ZB										
			2 CA	2004	203	2004	203	200	165	130	12	135	95	15	M10	118	86	43	AGN 7	70	OMT 2033C20	POL-2	4	OMT 2033CA2										
			2 U	2004	203	2004	203	200	165	130	12	135	95	15	M10	118	86	43	AGN 7A	70	OMT 2033C20	POL-2	4	OMT 2033U2										
ZF	-	-	LB21	LBS21	200	165	130	12	135	95	15	M10	118	86	43	AGN 202	70	OMT 2033C20	POL-2	4	OMT 2033ZF													
1,1 ± 1,5	90	1,5 ± 2	U 1 P	2002	201	2002	201	200	165	130	12	135	95	15	M10	90	69	34	AGN 8	70	OMT 2033C31	POL-2	4	OMT 2033U1P	P - 250 A - 250									
			1 C	2003	202	2003	202	200	165	130	12	135	95	15	M10	90	69	34	AGN 9	70	OMT 2033C31	POL-2	4	OMT 2033C1										
			1 M	2003	202	2003	202	200	165	130	12	135	95	15	M10	90	69	34	AGN 9A	70	OMT 2033C31	POL-2	4	OMT 2033M1										
			ZB	-	-	LB20	LBS20	200	165	130	12	135	95	15	M10	90	69	34	AGN 201	70	OMT 2033C31	POL-2	4	OMT 2033ZB										
			U 1 P	2002	201	2002	201	200	165	130	12	135	95	15	M10	90	69	34	AGN 8	70	OMT 2033C31	POL-2	4	OMT 2033U1P										
			1 C	2003	202	2003	202	200	165	130	12	135	95	15	M10	90	69	34	AGN 9	70	OMT 2033C31	POL-2	4	OMT 2033C1										
			1 M	2003	202	2003	202	200	165	130	12	135	95	15	M10	90	69	34	AGN 9A	70	OMT 2033C31	POL-2	4	OMT 2033M1										
			ZB	-	-	LB20	LBS20	200	165	130	12	135	95	15	M10	90	69	34	AGN 201	70	OMT 2033C31	POL-2	4	OMT 2033ZB										
			2 CA	2004	203	2004	203	200	165	130	12	135	95	15	M10	118	86	43	AGN 10	70	OMT 2033C31	POL-2	4	OMT 2033CA2										
			2 U	2004	203	2004	203	200	165	130	12	135	95	15	M10	118	86	43	AGN 10A	70	OMT 2033C31	POL-2	4	OMT 2033U2										
			ZF	-	-	LB21	LBS21	200	165	130	12	135	95	15	M10	118	86	43	AGN 203	70	OMT 2033C31	POL-2	4	OMT 2033ZF										
			2 CA	2004	203	2004	203	200	165	130	12	135	95	15	M10	118	86	43	AGN 10	70	OMT 2033C31	POL-2	4	OMT 2033CA2										
			2 U	2004	203	2004	203	200	165	130	12	135	95	15	M10	118	86	43	AGN 10A	70	OMT 2033C31	POL-2	4	OMT 2033U2										
			ZF	-	-	LB21	LBS21	200	165	130	12	135	95	15	M10	118	86	43	AGN 203	70	OMT 2033C31	POL-2	4	OMT 2033ZF										
2,2 ± 4	100 ± 112	3 ± 5,5	U 1 P	2501	250	2501	250	250	215	180	14	185	105	21	M12	118	86	43	AGN 11	74	OMT 3040C36	POL-3	4	OMT 3030U1P	P - 250 A - 250									
			1 C	2502	251	2502	251	250	215	180	14	185	105	21	M12	118	86	43	AGN 12	74	OMT 3040C36	POL-3	4	OMT 3030C1										
			1 M	2502	251	2502	251	250	215	180	14	185	105	21	M12	118	86	43	AGN 12A	74	OMT 3040C36	POL-3	4	OMT 3030M1										
			2 CA	2503	252	2503	252	250	215	180	14	185	105	21	M12	118	86	43	AGN 12B	74	OMT 3040C36	POL-3	4	OMT 3030CA2										
			2 U	2503	252	2503	252	250	215	180	14	185	105	21	M12	118	86	43	AGN 12C	74	OMT 3040C36	POL-3	4	OMT 3030U2										
			ZB	-	-	LB22	LBS22	250	215	180	14	185	105	21	M12	118	86	43	AGN 204	74	OMT 3040C36	POL-3	4	OMT 3030ZB										
			ZF	-	-	LB23	LBS23	250	215	180	14	185	105	21	M12	118	86	43	AGN 205	74	OMT 3040C36	POL-3	4	OMT 3030ZF										
			2 CA	2504	253	2504	253	250	215	180	14	185	115	21	M12	170	120	59	AGN 13	84	OMT 3040C36	POL-3	4	OMT 3040CA2										
			2 U	2504	253	2504	253	250	215	180	14	185	115	21	M12	170	120	59	AGN 13A	84	OMT 3040C36	POL-3	4	OMT 3040U2										
			T 250	2505	254	2505	254	250	215	180	14	185	115	21	M12	170	120	59	AGN 14	84	OMT 3040C36	POL-3	4	OMT 3040U3										
			3 U	2506	255	2506	255	250	215	180	14	185	115	21	M12	170	120	59	AGN 14	84	OMT 3040C36	POL-3	4	OMT 3040U3										
			M 3	2507	256	2507	256	250	215	180	14	185	115	21	M12	170	120	59	AGN 14	84	OMT 3040C36	POL-3	4	OMT 3040U3										
			T 3	2508	257	2508	257	250	215	180	14	185	115	21	M12	170	120	59	AGN 14	84	OMT 3040C36	POL-3	4	OMT 3040										

MOTORI FLANGIA B3-B5 / MOTORS WITH FLANGE B3-B5

Motore 4 poli 1450 giri/1' Motor power 4 p. 1450 revs/min		Rif. pompa Pump code	Lanterna Bellhousing				Dimensione lanterna (mm) Dimensions of bellhousing (mm)										Giunto completo serie ND Complete coupling ND series		Semigiunto Motore Halfcoupling motor side		Insero elastico Rubber spider		Semigiunto pompa Halfcoupling pump side		Piedino Foot flange	Anello Amm. Slip and/or damping ring
kW	Taglia Size		HP	LE	LSE	L	LS	A	B	C	D	F	G	H	P	Q	R	S	Codice Part number	H	Codice Part number	Codice Part num.	I	Codice Part number		
5,5 ÷ 9	132	7,5 ÷ 12,5	2 CA	3001	300	3001	300	300	265	230	14	235	143	21	M12	170	120	59	AGN 15	104	OMT 4050C47	POL-4	4	OMT 4050CA2		
			2 U	3001	300	3001	300	300	265	230	14	235	143	21	M12	170	120	59	AGN 15A	104	OMT 4050C47	POL-4	4	OMT 4050U2		
			T 250	3002	301	3002	301	300	265	230	14	235	143	21	M12	170	120	59	AGN 16	104	OMT 4050C47	POL-4	4	OMT 4050U3		
			3 U	3003	302	3003	302	300	265	230	14	235	143	21	M12	170	120	59	AGN 16	104	OMT 4050C47	POL-4	4	OMT 4050U3		
			M 3	3004	303	3004	303	300	265	230	14	235	143	21	M12	170	120	59	AGN 16	104	OMT 4050C47	POL-4	4	OMT 4050U3		
			T 3	3005	304	3005	304	300	265	230	14	235	143	21	M12	170	120	59	AGN 16	104	OMT 4050C47	POL-4	4	OMT 4050U3		
			ZF	-	-	LB26	LBS26	300	265	230	14	235	143	21	M12	170	120	59	AGN 208	104	OMT 4050C47	POL-4	4	OMT 4050ZF		
			ZG	-	-	LB27	LBS27	300	265	230	14	235	143	21	M12	170	120	59	AGN 209	104	OMT 4050C47	POL-4	4	OMT 4050ZG		
			35 M	3006	305	3006	305	300	265	230	14	235	143	21	M12	180	158	62	AGN 17	104	OMT 4050C47	POL-4	4	OMT 4050G35		
			35 G	3007	306	3007	306	300	265	230	14	235	143	21	M12	180	158	62	AGN 17	104	OMT 4050C47	POL-4	4	OMT 4050G35		
			35 U	3007	306	3007	306	300	265	230	14	235	143	21	M12	180	158	62	AGN 18	104	OMT 4050C47	POL-4	4	OMT 4050U35		
			11 ÷ 15	160	15 ÷ 20	2 CA	-	-	3511	350	350	300	250	18	253	178	25	M16	230	175	77	AGN 19	124	OMT 5060C51	POL-5	4
2 U	-	-				3511	350	350	300	250	18	253	178	25	M16	230	175	77	AGN 19A	124	OMT 5060C51	POL-5	4	OMT 5060U2		
T 250	3512	351				3512	351	350	300	250	18	253	178	25	M16	230	175	77	AGN 20	124	OMT 5060C51	POL-5	4	OMT 5060U3		
3 U	3513	352				3513	352	350	300	250	18	253	178	25	M16	230	175	77	AGN 20	124	OMT 5060C51	POL-5	4	OMT 5060U3		
M 3	3514	353				3514	353	350	300	250	18	253	178	25	M16	230	175	77	AGN 20	124	OMT 5060C51	POL-5	4	OMT 5060U3		
T 3	3515	354				3515	354	350	300	250	18	253	178	25	M16	230	175	77	AGN 20	124	OMT 5060C51	POL-5	4	OMT 5060U3		
ZF	-	-				LB31	LBS31	350	300	250	18	253	178	25	M16	230	175	77	AGN 210	124	OMT 5060C51	POL-5	4	OMT 5060ZF		
ZG	-	-				LB32	LBS32	350	300	250	18	253	178	25	M16	230	175	77	AGN 212	124	OMT 5060C51	POL-5	4	OMT 5060ZG		
35 M	3506	355				-	-	350	300	250	18	253	188	25	M16	230	175	77	AGN 21	124	OMT 5060C51	POL-5	4	OMT 5060G35		
35 G	3507	356				-	-	350	300	250	18	253	188	25	M16	230	175	77	AGN 21	124	OMT 5060C51	POL-5	4	OMT 5060G35		
35 U	3507	356				-	-	350	300	250	18	253	188	25	M16	230	175	77	AGN 22	124	OMT 5060C51	POL-5	4	OMT 5060U35		
4 M	3508	357				-	-	350	300	250	18	253	188	25	M16	230	175	77	AGN 23	124	OMT 5060C51	POL-5	4	OMT 5060M4		
4 T	3508	357	-	-	350	300	250	18	253	188	25	M16	230	175	77	AGN 23	124	OMT 5060C51	POL-5	4	OMT 5060M4					
4 U	3509	358	-	-	350	300	250	18	253	188	25	M16	230	175	77	AGN 24	124	OMT 5060C51	POL-5	4	OMT 5060U4					
18,5 ÷ 22	180	25 ÷ 30	2 CA	-	-	3511	350	350	300	250	18	253	178	25	M16	230	175	77	AGN 25	124	OMT 5060C54	POL-5	4	OMT 5060CA2		
			2 U	-	-	3511	350	350	300	250	18	253	178	25	M16	230	175	77	AGN 25A	124	OMT 5060C54	POL-5	4	OMT 5060U2		
			T 250	3512	351	3512	351	350	300	250	18	253	178	25	M16	230	175	77	AGN 26	124	OMT 5060C54	POL-5	4	OMT 5060U3		
			3 U	3513	352	3513	352	350	300	250	18	253	178	25	M16	230	175	77	AGN 26	124	OMT 5060C54	POL-5	4	OMT 5060U3		
			M 3	3514	353	3514	353	350	300	250	18	253	178	25	M16	230	175	77	AGN 26	124	OMT 5060C54	POL-5	4	OMT 5060U3		
			T 3	3515	354	3515	354	350	300	250	18	253	178	25	M16	230	175	77	AGN 26	124	OMT 5060C54	POL-5	4	OMT 5060U3		
			ZF	-	-	LB31	LBS31	350	300	250	18	253	178	25	M16	230	175	77	AGN 211	124	OMT 5060C54	POL-5	4	OMT 5060ZF		
			ZG	-	-	LB32	LBS32	350	300	250	18	253	178	25	M16	230	175	77	AGN 213	124	OMT 5060C54	POL-5	4	OMT 5060ZG		
			35 M	3506	355	-	-	350	300	250	18	253	188	25	M16	230	175	77	AGN 27	124	OMT 5060C54	POL-5	4	OMT 5060G35		
			35 G	3507	356	-	-	350	300	250	18	253	188	25	M16	230	175	77	AGN 27	124	OMT 5060C54	POL-5	4	OMT 5060G35		
			35 U	3507	356	-	-	350	300	250	18	253	188	25	M16	230	175	77	AGN 28	124	OMT 5060C54	POL-5	4	OMT 5060U35		
			4 M	3508	357	-	-	350	300	250	18	253	188	25	M16	230	175	77	AGN 29	124	OMT 5060C54	POL-5	4	OMT 5060M4		
4 T	3508	357	-	-	350	300	250	18	253	188	25	M16	230	175	77	AGN 29	124	OMT 5060C54	POL-5	4	OMT 5060M4					
4 U	3509	358	-	-	350	300	250	18	253	188	25	M16	230	175	77	AGN 30	124	OMT 5060C54	POL-5	4	OMT 5060U4					
30	200	40	T 250	4001	400	-	-	400	350	300	18	299	188	25	M16	272	247	123	AGN 31	150,5	OMT 6080C56	POL-6	8	OMT 6062U3		
			3 U	4002	401	-	-	400	350	300	18	299	188	25	M16	272	247	123	AGN 31	150,5	OMT 6080C56	POL-6	8	OMT 6062U3		
			M 3	4003	402	-	-	400	350	300	18	299	188	25	M16	272	247	123	AGN 31	150,5	OMT 6080C56	POL-6	8	OMT 6062U3		
			T 3	4004	403	-	-	400	350	300	18	299	188	25	M16	272	247	123	AGN 31	150,5	OMT 6080C56	POL-6	8	OMT 6062U3		
			35 M	4005	404	-	-	400	350	300	18	299	188	25	M16	272	247	123	AGN 32	150,5	OMT 6080C56	POL-6	8	OMT 6062G35		
			35 G	4006	405	-	-	400	350	300	18	299	188	25	M16	272	247	123	AGN 32	150,5	OMT 6080C56	POL-6	8	OMT 6062G35		
			35 U	4006	405	-	-	400	350	300	18	299	188	25	M16	272	247	123	AGN 32A	150,5	OMT 6080C56	POL-6	8	OMT 6062U35		
			4 M	4007	406	-	-	400	350	300	18	299	188	25	M16	272	247	123	AGN 33	150,5	OMT 6080C56	POL-6	8	OMT 6062M4		
			4 T	4007	406	-	-	400	350	300	18	299	188	25	M16	272	247	123	AGN 33	150,5	OMT 6080C56	POL-6	8	OMT 6062M4		
			4 U	4008	407	-	-	400	350	300	18	299	188	25	M16	272	247	123	AGN 33A	150,5	OMT 6080C56	POL-6	8	OMT 6062U4		
			ZG	-	-	LB30	LBS30	400	350	300	18	299	188	25	M16	272	247	123	AGN 214	150,5	OMT 6080C56	POL-6	8	OMT 6062ZG		
			37 ÷ 45	225	50 ÷ 60	35 M	-	-	4501*	450*	450	400	350	18	350	218	25	M16	287,5	175	137,5	AGN 34	150,5	OMT 6080C57	POL-6	8
35 G	-	-				4502*	451*	450	400	350	18	350	218	25	M16	287,5	175	137,5	AGN 34	150,5	OMT 6080C57	POL-6	8	OMT 6062G35		
35 U	-	-				4502*	451*	450	400	350	18	350	218	25	M16	287,5	175	137,5	AGN 34A	150,5	OMT 6080C57	POL-6	8	OMT 6062U35		
4 M	-	-				4503*	452*	450	400	350	18	350	218	25	M16	287,5	175	137,5	AGN 35	150,5	OMT 6080C57	POL-6	8	OMT 6062M4		
4 T	-	-				4503*	452*	450	400																	

MOTORI FLANGIA B14 / MOTORS WITH FLANGE B14

Motore 4 poli 1450 giri/1' Motor power 4 p. 1450 revs/min			Rif. pompa Pump code	Lanterna Bellhousing		Dimensione lanterna (mm) Dimensions of bellhousing (mm)										Giunto completo serie ND Complete coupling ND series		Semigiunto Motore Halfcoupling motor side		Inserto elastico Rubber spider		Semigiunto pompa Halfcoupling pump side		Piedino Foot flange	Anello amm. Damping ring
kW	Taglia Size	HP	L	LS	A	B	C	D	F	G	H	P	Q	R	S	Codice Part number	H	Codice Part number	Codice Part num.	I	Codice Part number				
0,12 ÷ 0,18	63	0,16 ÷ 0,25	0,5M	901	-	90	75	60	6,5	62	60	10	-	90	69	34	ND 01	54	ND 48A	R-42	16	ND 48P05M			
			0,5GT	901	-	90	75	60	6,5	62	60	10	-	90	69	34	ND 02	54	ND 48A	R-42	16	ND 48P05GT			
			U1P	902	-	90	75	60	6,5	62	60	10	-	90	69	34	ND 03	52	ND 48A	R-42	16	ND 48PU1P			
			1C	903	-	90	75	60	6,5	62	60	10	-	90	69	34	ND 04	52	ND 48A	R-42	16	ND 48P1C			
			1M	903	-	90	75	60	6,5	62	60	10	-	90	69	34	ND 05	52	ND 48A	R-42	16	ND 48P1M			
			ZB	LB 9	-	90	75	60	6,5	62	60	10	-	90	69	34	ND 198	52	ND 48A	R-42	16	ND 48PZB			
0,25 ÷ 0,37	71	0,35 ÷ 0,55	0,5M	1051	-	105	85	70	7	70	70	10	-	90	69	34	ND 1	64	ND 48B	R-42	16	ND 48P05M			
			0,5GT	1051	-	105	85	70	7	70	70	10	-	90	69	34	ND 1A	64	ND 48B	R-42	16	ND 48P05GT			
			U1P	1052	-	105	85	70	7	70	70	10	-	90	69	34	ND 2	62	ND 48B	R-42	16	ND 48PU1P			
			1C	1053	-	105	85	70	7	70	70	10	-	90	69	34	ND 3	62	ND 48B	R-42	16	ND 48P1C			
			1M	1053	-	105	85	70	7	70	70	10	-	90	69	34	ND 3A	62	ND 48B	R-42	16	ND 48P1M			
			ZB	LB 10	-	105	85	70	7	70	70	10	-	90	69	34	ND 199	62	ND 48B	R-42	16	ND 48PZB			
0,55 ÷ 0,75	80	0,75 ÷ 1	0,5M	1201	-	120	100	80	7	80	85	12	-	120	90	45	ND 4B	80	ND 48CG45	R-42	16	ND 48P05M			
			0,5GT	1201	-	120	100	80	7	80	85	12	-	120	90	45	ND 4C	80	ND 48CG45	R-42	16	ND 48P05GT			
			U1P	1202	-	120	100	80	7	80	85	12	-	120	90	45	ND 5A	98	ND 48CG45	R-42	16	ND 48PU1P			
			1C	1203	-	120	100	80	7	80	85	12	-	120	90	45	ND 6B	78	ND 48CG45	R-62	18	ND 48P1C			
			1M	1203	-	120	100	80	7	80	85	12	-	120	90	45	ND 6C	78	ND 48CG45	R-62	18	ND 48P1M			
			ZB	LB 11	-	120	100	80	7	80	85	12	-	120	90	45	ND 300	78	ND 48CG45	R-62	18	ND 48PZB			
			2	1204	-	120	100	80	7	80	85	12	-	120	90	45	ND 7B	77,5	ND 65AG38	R-62	18	ND 65P2			
			ZF	LB 12	-	120	100	80	7	80	85	12	-	120	90	45	ND 207	77,5	ND 65AG38	R-62	18	ND 65PZF			
1,1 ÷ 1,5	90	1,5 ÷ 2	U1P	1410	149	140	115	95	9,5	100	95	12	M8	120	90	45	ND 8	87	ND 65B	R-62	18	ND 65PU1P			
			1C	1411	150	140	115	95	9,5	100	95	12	M8	120	90	45	ND 9	87	ND 65B	R-62	18	ND 65P1C			
			1M	1411	150	140	115	95	9,5	100	95	12	M8	120	90	45	ND 9A	87	ND 65B	R-62	18	ND 65P1M			
			ZB	LB 40	LBS 40	140	115	95	9,5	100	95	12	M8	120	90	45	ND 201	87	ND 65B	R-62	18	ND 65PZB			
			2	1409	148	140	115	95	9,5	100	95	12	M8	120	90	45	ND 10	87	ND 65B	R-62	18	ND 65P2			
			ZF	LB 14	LBS 14	140	115	95	9,5	100	95	12	M8	120	90	45	ND 203	87	ND 65B	R-62	18	ND 65PZF			
2,2 ÷ 4	100 ÷ 112	3 ÷ 5,5	U1P	1610	169	160	130	110	9,5	114	105	14	M8	120	90	45	ND 11	97	ND 65C	R-62	18	ND 65PU1P			
			1C	1611	170	160	130	110	9,5	114	105	14	M8	120	90	45	ND 12	97	ND 65C	R-62	18	ND 65P1C			
			1M	1611	170	160	130	110	9,5	114	105	14	M8	120	90	45	ND 12A	97	ND 65C	R-62	18	ND 65P1M			
			ZB	LB 17	LBS 17	160	130	110	9,5	114	105	14	M8	120	90	45	ND 204	97	ND 65C	R-62	18	ND 65PZB			
			2	1609	168	160	130	110	9,5	114	105	14	M8	120	90	45	ND 13	97	ND 65C	R-62	18	ND 65P2			
			ZF	LB 16	LBS 16	160	130	110	9,5	114	105	14	M8	120	90	45	ND 206	97	ND 65C	R-62	18	ND 65PZF			
5,5 ÷ 7,5	132	7,5 ÷ 10	2	2015	-	200	165	130	11,5	137	139	16	-	150	132	72	ND 16B	127	ND 86BG80	R-82	20	ND 86P2			
			ZF	LB 41	-	200	165	130	11,5	137	139	16	-	150	132	72	ND 311	127	ND 86BG80	R-82	20	ND 86PZF			
			T250	2016	-	200	165	130	11,5	137	139	16	-	150	132	72	ND 17A	127	ND 86BG80	R-82	20	ND 86P3U			
			3U	2017	-	200	165	130	11,5	137	139	16	-	150	132	72	ND 17A	127	ND 86BG80	R-82	20	ND 86P3U			
			M3	2018	-	200	165	130	11,5	137	139	16	-	150	132	72	ND 17A	127	ND 86BG80	R-82	20	ND 86P3U			
			T3	2019	-	200	165	130	11,5	137	139	16	-	150	132	72	ND 17A	127	ND 86BG80	R-82	20	ND 86P3U			
			ZG	LB 42	-	200	165	130	11,5	137	139	16	-	150	132	72	ND 312	127	ND 86BG80	R-82	20	ND 86PZG			

FLANGIA / FLANGE

tipo / series **B14**

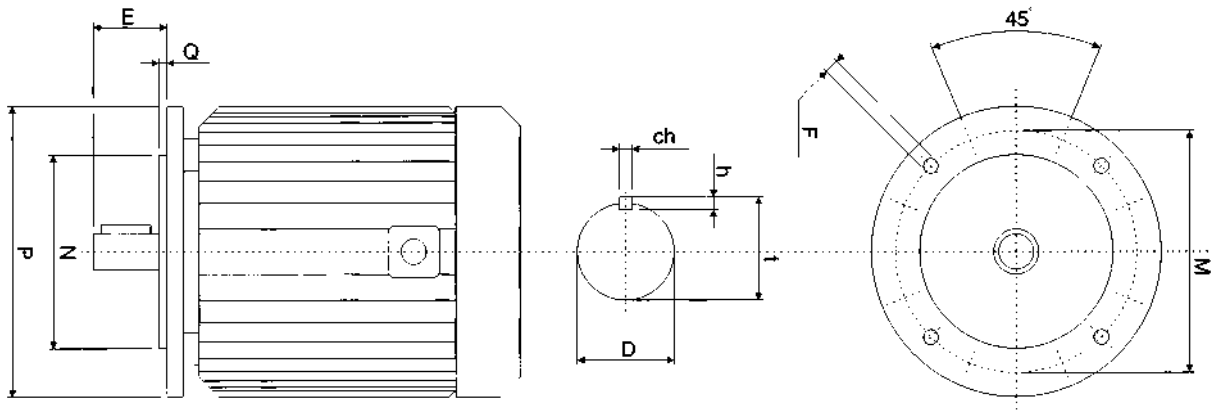

Taglia Size	Potenza / Motor power								Dimensioni / Dimensions									
	2 poli / 2 poles		4 poli / 4 poles		6 poli / 6 poles		8 poli / 8 poles		Dimensioni flangia / Flange dimensions					Dimensioni albero / Shaft dimensionst				
	2900 giri/min - revs/min		1450 giri/min - revs/min		960 giri/min - revs/min		720 giri/min - revs/min		P	M	N	Q	F	D	E	ch	h	t
63	0,18	0,24	0,12	0,16					90	75	60	2,5	M5	11	23	4	4	12,5
	0,25	0,35	0,185	0,25														
71	0,37	0,55	0,25	0,35					105	85	70	2,5	M6	14	30	5	5	16
	0,55	0,75	0,37	0,55														
80	0,75	1	0,55	0,75	0,37	0,5			120	100	80	3	M6	19	40	6	6	21,5
	1,1	1,5	0,75	1	0,55	0,75												
90S	1,5	2	1,1	1,5	0,75	1			140	115	95	3	M8	24	50	8	7	27
90L	2,2	3	1,5	2	1,1	1,5			140	115	95	3	M8	24	50	8	7	27
100L	3	4	2,2	3	1,5	2	0,75	1	160	130	110	3,5	M8	28	60	8	7	31
			3	4			1,1	1,5										
112M	4	5,5	4	5,5	2,2	3	1,5	2	160	130	110	3,5	M8	28	60	8	7	31
132S	7,5	10	5,5	7,5	3	4	2,2	3	200	165	130	3,5	M10	38	80	10	8	41
132M	9	12,5	7,5	10	5,5	7,5	3	4	200	165	130	3,5	M10	38	80	10	8	41

**ACCOPIAMENTO POMPE AD INGRANAGGI
CON FLANGIATURE RETTANGOLARI E MOTORI ENDOTERMICI**

CONNECTIONS BETWEEN GEAR PUMPS WITH RECTANGULAR FLANGE AND ENDOTHERMIC ENGINES

LANTERNA / BELLHOUSING

tipo / series **LMH**

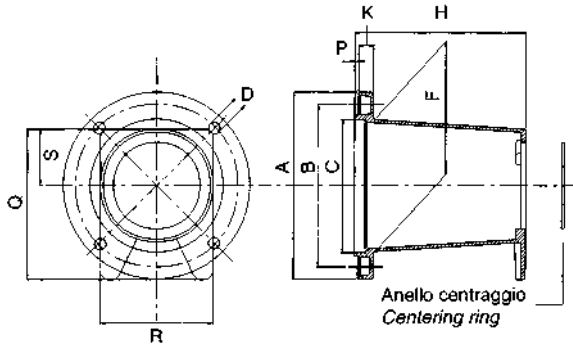

LANTERNA / BELLHOUSING

tipo / series **LB**

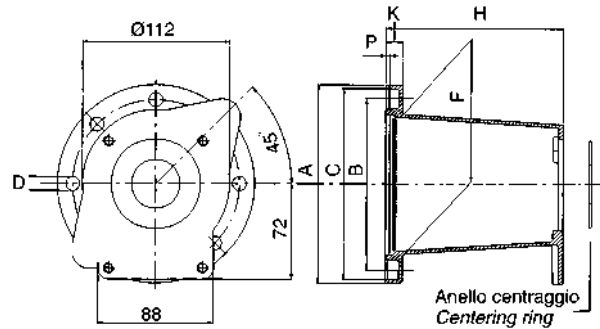

Potenza motore Motor power		Albero Shaft	Rif. pompa Pump code	Lanterna Bellhousing	Dimensione lanterna (mm) Dimensions of bellhousing (mm)													Giunto completo serie ND Complete coupling ND series		Semigiunto Motore Halfcoupling motor side		Inserto elastico Rubber spider		Semigiunto pompa Halfcoupling pump side		Anello di centraggio Centering ring	
kW	HP				Codice Part number	A	B	C	D	F	H	K	P	Q	R	S	Codice Part number	H	Codice Part number	H	Codice Part num.	I	Codice Part number	Codice P. number			
2,2 ÷ 4	3 ÷ 5,5	Ø 18 ch. 5	U1P	LMH151	110	92	78,5	9	78	98	12	3	90	70	34	ND 500	87	NS 48CC16	R-42	16	ND 48PU1P	RC05-254					
			1C	LMH152	110	92	78,5	9	78	98	12	3	90	70	34	ND 501	87	NS 48CC16	R-42	16	ND 48P1C	RC05-30					
			1M	LMH152	110	92	78,5	9	78	98	12	3	90	70	34	ND 502	87	NS 48CC16	R-42	16	ND 48P1M	RC05-30					
		Ø 19,05 ch. 4,76	U1P	LMH151	110	92	78,5	9	78	98	12	3	90	70	34	ND 510	87	ND 48CC22	R-42	16	ND 48PU1P	RC05-254					
			1C	LMH152	110	92	78,5	9	78	98	12	3	90	70	34	ND 511	87	ND 48CC22	R-42	16	ND 48P1C	RC05-30					
			1M	LMH152	110	92	78,5	9	78	98	12	3	90	70	34	ND 512	87	ND 48CC22	R-42	16	ND 48P1M	RC05-30					
5 ÷ 13,5	7 ÷ 18	Ø 25 ch. 7	U1P	LMH401	146	127	110	9	110	134	12	3	118	91	43,5	ND 600	106	ND 65MC33	R-62	18	ND 65PU1P	RC1-254					
			1C	LMH402	146	127	110	9	110	134	12	3	118	91	43,5	ND 601	106	ND 65MC33	R-62	18	ND 65P1C	RC1-30					
			1M	LMH402	146	127	110	9	110	134	12	3	118	91	43,5	ND 602	106	ND 65MC33	R-62	18	ND 65P1M	RC1-30					
			2	LMH403	146	127	110	9	110	134	12	3	118	91	43,5	ND 603	106	ND 65MC33	R-62	18	ND 65P2	RC1-365					
			ZF	LMH404	146	127	110	9	110	134	12	3	118	91	43,5	ND 605	106	ND 65MC33	R-62	18	ND 65P2F	-					
			U1P	LMH401	146	127	110	9	110	134	12	3	118	91	43,5	ND 610	106	ND 65MC35	R-62	18	ND 65PU1P	RC1-254					
		Ø 25,4 ch. 6,35	1C	LMH402	146	127	110	9	110	134	12	3	118	91	43,5	ND 611	106	ND 65MC35	R-62	18	ND 65P1C	RC1-30					
			1M	LMH402	146	127	110	9	110	134	12	3	118	91	43,5	ND 612	106	ND 65MC35	R-62	18	ND 65P1M	RC1-30					
			2	LMH403	146	127	110	9	110	134	12	3	118	91	43,5	ND 613	106	ND 65MC35	R-62	18	ND 65P2	RC1-365					
			ZF	LMH404	146	127	110	9	110	134	12	3	118	91	43,5	ND 615	106	ND 65MC35	R-62	18	ND 65P2F	-					
			U1P	LB152-U1P	152	128	146	10,5	110	142	15	3,5	-	-	-	ND 600	106	ND 65MC33	R-62	18	ND 65PU1P	RC1-254					
			1C	LB152-1CM	152	128	146	10,5	110	142	15	3,5	-	-	-	ND 601	106	ND 65MC33	R-62	18	ND 65P1C	RC1-30					
		Ø 25,4 ch. 6,35	1M	LB152-1CM	152	128	146	10,5	110	142	15	3,5	-	-	-	ND 602	106	ND 65MC33	R-62	18	ND 65P1M	RC1-30					
			2	LB152-2	152	128	146	10,5	110	142	15	3,5	-	-	-	ND 603	106	ND 65MC33	R-62	18	ND 65P2	RC1-365					
			U1P	LB152-U1P	152	128	146	10,5	110	142	15	3,5	-	-	-	ND 610	106	ND 65MC35	R-62	18	ND 65PU1P	RC1-254					
			1C	LB152-1CM	152	128	146	10,5	110	142	15	3,5	-	-	-	ND 611	106	ND 65MC35	R-62	18	ND 65P1C	RC1-30					
			1M	LB152-1CM	152	128	146	10,5	110	142	15	3,5	-	-	-	ND 612	106	ND 65MC35	R-62	18	ND 65P1M	RC1-30					
			2	LB152-2	152	128	146	10,5	110	142	15	3,5	-	-	-	ND 613	106	ND 65MC35	R-62	18	ND 65P2	RC1-365					
		Ø 25 ch. 7	T250	LB152-T250	152	128	146	10,5	110	155	15	3,5	-	-	-	ND 606	106	ND 65MC33	R-62	18	ND 65Q3U	-					
			3U	LB152-3U	152	128	146	10,5	110	155	15	3,5	-	-	-	ND 606	106	ND 65MC33	R-62	18	ND 65Q3U	-					
			M3	LB152-M3	152	128	146	10,5	110	155	15	3,5	-	-	-	ND 606	106	ND 65MC33	R-62	18	ND 65Q3U	-					
			T250	LB152-T250	152	128	146	10,5	110	155	15	3,5	-	-	-	ND 616	116	ND 65MC35	R-62	18	ND 65Q3U	-					
			3U	LB152-3U	152	128	146	10,5	110	155	15	3,5	-	-	-	ND 616	116	ND 65MC35	R-62	18	ND 65Q3U	-					
			M3	LB152-M3	152	128	146	10,5	110	155	15	3,5	-	-	-	ND 616	116	ND 65MC35	R-62	18	ND 65Q3U	-					

Motore a scoppio HP 18 con diametro di centraggio flangia Ø 163,5 mm

Internal combustion engines, 18 HP, with centering flange diameter Ø 163,5 mm

Potenza motore Motor power		Albero Shaft	Rif. pompa Pump code	Lanterna Bellhousing	Dimensione lanterna (mm) Dimensions of bellhousing (mm)													Giunto completo serie ND Complete coupling ND series		Semigiunto Motore Halfcoupling motor side		Inserto elastico Rubber spider		Semigiunto pompa Halfcoupling pump side		Anello di centraggio Centering ring	
kW	HP				Codice Part number	A	B	C	D	F	G	H	P	Q	R	S	Codice Part number	H	Codice Part number	H	Codice Part num.	I	Codice Part number	Codice P. number			
13,5	18	Ø 25 ch. 7	U1P	LB170-U1P	170	128	163,5	10,5	110	142	15	3,5	-	-	-	ND 600	106	ND 65MC33	R-62	18	ND 65PU1P	RC1-254					
			1C	LB170-1CM	170	128	163,5	10,5	110	142	15	3,5	-	-	-	ND 601	106	ND 65MC33	R-62	18	ND 65P1C	RC1-30					
			1M	LB170-1CM	170	128	163,5	10,5	110	142	15	3,5	-	-	-	ND 602	106	ND 65MC33	R-62	18	ND 65P1M	RC1-30					
			2	LB170-2	170	128	163,5	10,5	110	142	15	3,5	-	-	-	ND 603	106	ND 65MC33	R-62	18	ND 65P2	RC1-365					
			T250	LB170-T250	170	128	163,5	10,5	110	155	15	3,5	-	-	-	ND 606	116	ND 65MC33	R-62	18	ND 65Q3U	RC2-508					
			3U	LB170-3U	170	128	163,5	10,5	110	155	15	3,5	-	-	-	ND 606	116	ND 65MC33	R-62	18	ND 65Q3U	RC2-508					
		Ø 25,4 ch. 6,35	M3	LB170-M3	170	128	163,5	10,5	110	155	15	3,5	-	-	-	ND 606	116	ND 65MC33	R-62	18	ND 65Q3U	RC2-508					
			U1P	LB170-U1P	170	128	163,5	10,5	110	142	15	3,5	-	-	-	ND 610	106	ND 65MC35	R-62	18	ND 65PU1P	RC1-254					
			1C	LB170-1CM	170	128	163,5	10,5	110	142	15	3,5	-	-	-	ND 611	106	ND 65MC35	R-62	18	ND 65P1C	RC1-30					
			1M	LB170-1CM	170	128	163,5	10,5	110	142	15	3,5	-	-	-	ND 612	106	ND 65MC35	R-62	18	ND 65P1M	RC1-30					
			2	LB170-2	170	128	163,5	10,5	110	142	15	3,5	-	-	-	ND 613	106	ND 65MC35	R-62	18	ND 65P2	-					
			T250	LB170-T250	170	128	163,5	10,5	110	155	15	3,5	-	-	-	ND 616	116	ND 65MC35	R-62	18	ND 65Q3U	-					
		Ø 25,4 ch. 6,35	3U	LB170-3U	170	128	163,5	10,5	110	155	15	3,5	-	-	-	ND 616	116	ND 65MC35	R-62	18	ND 65Q3U	-					
			M3	LB170-M3	170	128	163,5	10,5	110	155	15	3,5	-	-	-	ND 616	116	ND 65MC35	R-62	18	ND 65Q3U	-					

ACCOPIAMENTO POMPE AD INGRANAGGI CON FLANGIATURE RETTANGOLARI E MOTORI ENDOTERMICI

01

CONNECTIONS BETWEEN GEAR PUMPS WITH RECTANGULAR FLANGE AND ENDOTHERMIC ENGINES

LANTERNA / BELLHOUSING

tipo / series **LB**

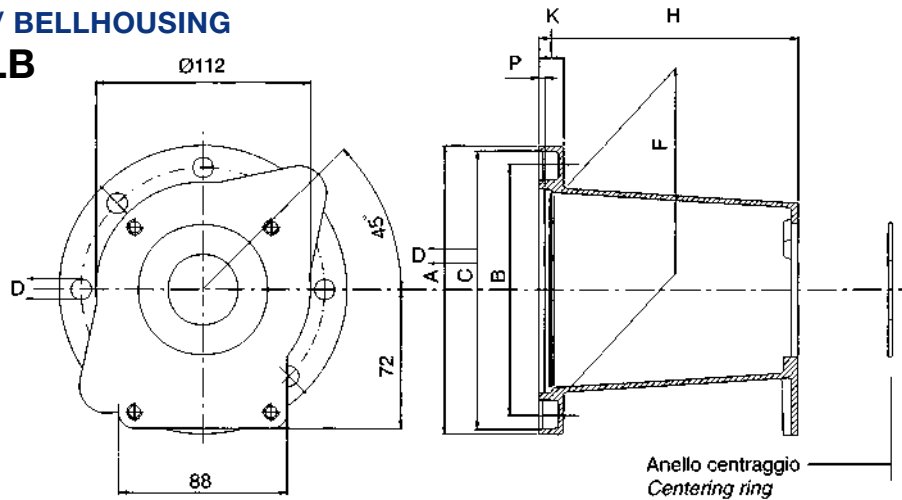

Potenza motore Motor power		Albero Shaft	Rif. pompa Pump code	Lanterna Bellhousing	Dimensione lanterna (mm) Dimensions of bellhousing (mm)								Giunto completo serie ND Complete coupling ND series		Semigiunto Motore Halfcoupling motor side		Inserito elastico Rubber spider		Semigiunto pompa Halfcoupling pump side	
kW	HP				Codice Part number	A	B	C	D	F	H	K	P	Codice Part number	H	Codice Part number	Codice Part num.	I	Codice Part number	
5 13,5	7 18	$\varnothing 25$ ch. 7	SAE A	LB152-825A	152	127	146	10	110	142	15	3,5	ND 700	124,5	ND 65MC33	R-62	18	ND 65H4D22		
			SAE B	LB152-101A	152	127	146	10	110	142	15	3,5	ND 701	124,5	ND 65MC33	R-62	18	ND 65H4D99		
			ISO 80-2	LB152-80E	152	127	146	10	110	142	15	3,5	ND 702	124,5	ND 65MC33	R-62	18	ND 65H4D24		
			ISO 100-2	LB152-100E	152	127	146	10	110	142	15	3,5	ND 703	124,5	ND 65MC33	R-62	18	ND 65H4D34		
		$\varnothing 25,4$ ch. 6,35	SAE A	LB152-825A	152	127	146	10	110	142	15	3,5	ND 710	124,5	ND 65MC35	R-62	18	ND 65H4D22		
			SAE B	LB152-101A	152	127	146	10	110	142	15	3,5	ND 711	124,5	ND 65MC35	R-62	18	ND 65H4D99		
			ISO 80-2	LB152-80E	152	127	146	10	110	142	15	3,5	ND 712	124,5	ND 65MC35	R-62	18	ND 65H4D24		
			ISO 100-2	LB152-100E	152	127	146	10	110	142	15	3,5	ND 713	124,5	ND 65MC35	R-62	18	ND 65H4D34		

Motore a scoppio HP 8 con albero speciale Internal combustion engines, 8 HP, with special shaft

Potenza motore Motor power		Albero Shaft	Rif. pompa Pump code	Lanterna Bellhousing	Dimensione lanterna (mm) Dimensions of bellhousing (mm)								Giunto completo serie ND Complete coupling ND series		Semigiunto Motore Halfcoupling motor side		Inserito elastico Rubber spider		Semigiunto pompa Halfcoupling pump side	
kW	HP				Codice Part number	A	B	C	D	F	H	K	P	Codice Part number	H	Codice Part number	Codice Part num.	I	Codice Part number	
5,75	8	$\varnothing 25,4$ ch. 6,35	SAE A	LB152-825A	152	127	146	10	110	142	15	3,5	ND 720	114,5	ND 65MC35	R-62	18	ND 65H8D22		
			SAE B	LB152-101A	152	127	146	10	110	142	15	3,5	ND 721	114,5	ND 65MC35	R-62	18	ND 65H8D99		
			ISO 80-2	LB152-80E	152	127	146	10	110	142	15	3,5	ND 722	114,5	ND 65MC35	R-62	18	ND 65H8D24		

Motore a scoppio HP18 con diametro di centraggio flangia $\varnothing 163,5$ mm Internal combustion engines, 18 HP, with centering flange diameter $\varnothing 163,5$ mm

Potenza motore Motor power		Albero Shaft	Rif. pompa Pump code	Lanterna Bellhousing	Dimensione lanterna (mm) Dimensions of bellhousing (mm)								Giunto completo serie ND Complete coupling ND series		Semigiunto Motore Halfcoupling motor side		Inserito elastico Rubber spider		Semigiunto pompa Halfcoupling pump side	
kW	HP				Codice Part number	A	B	C	D	F	H	K	P	Codice Part number	H	Codice Part number	Codice Part num.	I	Codice Part number	
13,5	18	$\varnothing 25$ ch. 7	SAE A	LB170-825A	170	127	163,5	10	110	142	15	3,5	ND 700	124,5	ND 65MC33	R-62	18	ND 65H4D22		
			SAE B	LB170-101A	170	127	163,5	10	110	142	15	3,5	ND 701	124,5	ND 65MC33	R-62	18	ND 65H4D99		
			ISO 80-2	LB170-80E	170	127	163,5	10	110	142	15	3,5	ND 702	124,5	ND 65MC33	R-62	18	ND 65H4D24		
			ISO 100-2	LB170-100E	170	127	163,5	10	110	142	15	3,5	ND 703	124,5	ND 65MC33	R-62	18	ND 65H4D34		
		$\varnothing 25,4$ ch. 6,35	SAE A	LB170-825A	170	127	163,5	10	110	142	15	3,5	ND 710	124,5	ND 65MC35	R-62	18	ND 65H4D22		
			SAE B	LB170-101A	170	127	163,5	10	110	142	15	3,5	ND 711	124,5	ND 65MC35	R-62	18	ND 65H4D99		
			ISO 80-2	LB170-80E	170	127	163,5	10	110	142	15	3,5	ND 712	124,5	ND 65MC35	R-62	18	ND 65H4D24		
			ISO 100-2	LB170-100E	170	127	163,5	10	110	142	15	3,5	ND 713	124,5	ND 65MC35	R-62	18	ND 65H4D34		

OMT Group ha ampliato la gamma inserendo le nuove lanterne per motori endotermici Kubota.

OMT Group has expanded the range by introducing the new bellhousings for Kubota endothermic engines.

Il KIT è composto da un mozzo metallico fissato sull'albero della pompa, una flangia in nylon per la trasmissione del moto e una campana in fusione di alluminio per il supporto della pompa.

Le caratteristiche principali di questa applicazione sono:

- Compensazione dei vari disallineamenti
- Salvaguardia dei componenti della pompa
- Bassa rumorosità
- Semplicità di montaggio
- Ingombri ridotti

APPLICAZIONI: Sistemi di accoppiamento per la trasmissione del moto in macchine operatrici mobili, veicoli terrestri, imbarcazioni, gruppi elettrogeni, pompe idrauliche.

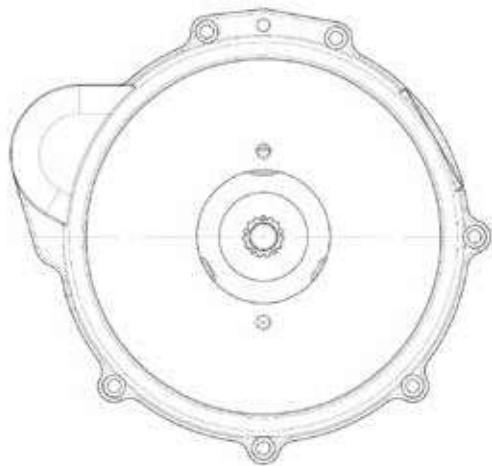

Consulta la **pagina web dedicata** alle lanterne per motore Kubota per gli aggiornamenti.

Per avere maggiori informazioni sugli accoppiati per motori Kubota disponibili, contatta il nostro ufficio tecnico omtgroup@omtgroup.it



The KIT consists of a metal hub fixed to the pump shaft, a nylon flange for transmitting the motion and a cast iron or aluminum bellhousing for supporting the pump.

The main features of this application are:

- Compensation of various misalignments
- Protection of the pump components
- Low noise levels
- Simple installation
- Reduced overall dimensions

APPLICAZIONI: Couplings systems for motion transmission in mobile operating machines, land vehicles, boats, power generators, hydraulic pumps.

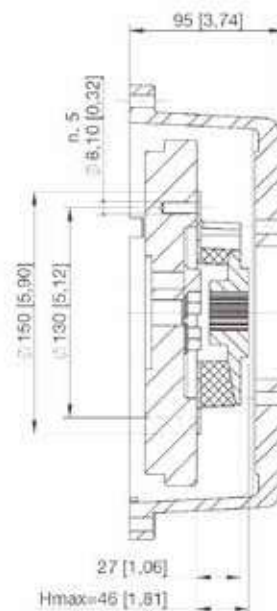

Check the bellhousings for Kubota engine **web page** for updates.

For more information on couplings for Kubota engines availables, contact our technical office at omtgroup@omtgroup.it

ANELLI AMMORTIZZANTI / DAMPING RINGS

tipo / series **A**

Costituiti da due anelli con interposta gomma vulcanizzata, vengono applicati tra lanterna e coperchio del serbatoio per smorzare le vibrazioni generate dalla trasmissione. Resistenti agli olii minerali possono lavorare fino ad una temperatura di + 80°C, riducendo la rumorosità del sistema di circa 3÷5 decibel.

These articles are made of two rings moulded into vulcanized rubber. Interposed between the bellhousing and the tank cover, they diminish the noise created by the power transmission by approx. 3÷5 dB. The employed rubber is mineral oil resistant, max. working temperature is 80°C.

Tabella / Table 22

Codice Part number	Dimensioni (mm) / Dimensions (mm)					
	A	B	C	D	E	F
A-200	146	200	165	15	43	M10
A-250	191	250	215	18	48	M12
A-300	238	300	265	18	53	M12
A-350	261	350	300	24	61,5	M16
A-400	311	400	350	24	69	M16

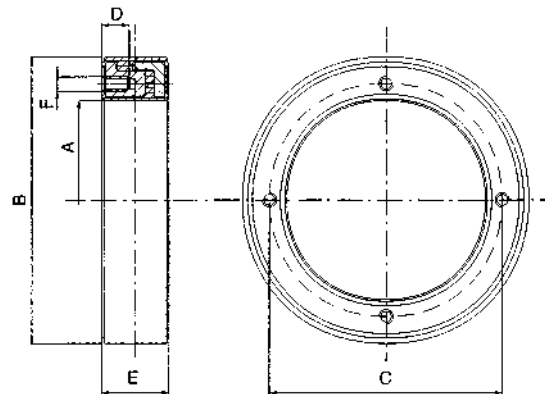

SUPPORTO MOTORE A PIEDINO / FOOT FLANGES

tipo / series **P**

Costruiti in lega di alluminio ad elevata resistenza meccanica vengono utilizzati quali supporti per lanterne con flangiatura normalizzata B5 sino ad un diametro esterno del motore di 350 mm. Da un Ø 400 est. del motore i piedini vengono costruiti in ferro.

Manufactured of high resistance aluminium alloy, these flanges are used to support our bellhousings with standard B5 flange up to an external diameter of the motor of Ø 350 mm. From Ø 400 upwards these foot flanges are made of steel.

Tabella / Table 23

Codice Part number	Dimensioni (mm) / Dimensions (mm)														
	A	B	C	D	E	F	G	I	N	O	P	Q	R	T	V
P160	165	135	80	100	45	10	45	98	80	111	130	10	9	35	9
P200	202	168	103	127	54	19	54	123	100	140	165	22	11,5	42,5	9
P250	252	220	130	155	105	25	25	150	125	180	215	25	13	92,5	11
P300	302	265	160	190	115	25	50	175	150	240	265	25	13	100	13
P350	362	310	250	286	183	30	73	205	175	256	300	30	18	165	15
P400	410	360	520	570	350	15	205	260	175	301	350	15	18	325	18
P450	460	400	590	640	390	15	235	295	200	351	400	15	18	365	18
P550	560	500	690	740	470	15	255	350	250	450	500	15	18	445	18

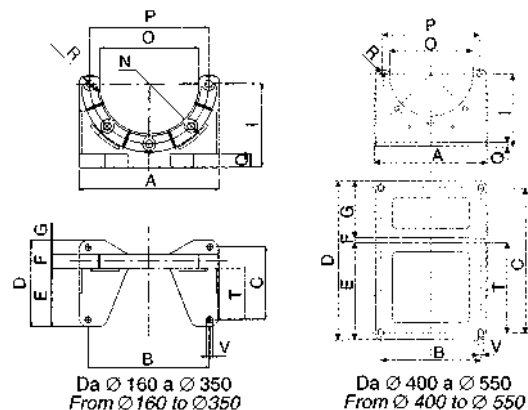

GUARNIZIONI / GASKETS

tipo / series **GL**

Guarnizioni in guarnital per lanterne. Tali guarnizioni vengono poste tra lanterne e serbatoi quale elemento di tenuta.

Gaskets for bellhousings, made of GUARNITAL. They are interposed between bellhousing and the oil tank.

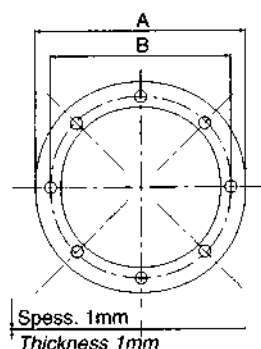

Codice Part number	Dimensioni (mm) Dimensions (mm)	
	A	B
GL 140	140	115
GL 160	160	130
GL 200	200	165
GL 250	250	215
GL 300	300	265
GL 350	350	300
GL 400	400	350

GUARNIZIONI / GASKETS

tipo / series **GP**

Guarnizioni in guarnital per pompe ad ingranaggi. Tali guarnizioni vengono poste tra pompa e lanterna quale elemento di tenuta.

Gaskets for gear pumps, made of GUARNITAL. They are interposed between bellhousing and the pump.

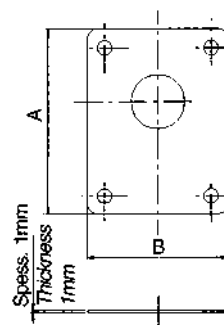

Codice Part number	Dimensioni (mm) Dimensions (mm)	
	A	B
GP 05	82	50
GP 1	90	69
GP 05-1M	90	69
GP 2	118	86
GP ZF	121	91
GP 3	170	120
GP 35	180	158
GP 4	230	175

BARRE AMMORTIZZANTI PER PIEDINI / DAMPING RODS FOR OMT FOOT FLANGES

 tipo / series **BMA - P****

Costruiti in lega di acciaio e costituiti da 2 barre tra le quali vi si interpone uno strato di gomma vulcanizzata antiolio; tale componente viene applicato tra piedino e coperchio del serbatoio, oppure tra il motore ed il suolo, dove vi sono le maggiori vibrazioni. I pattini ammortizzanti possono lavorare fino ad una temperatura di + 80°C, riducendo la rumorosità 3÷5 decibel.

In steel, they are made of two bars moulded into vulcanized rubber; they are used either between OMT Group foot flange and oiltank cover or between the motor and the ground where vibrations are higher. They can work up to + 80°C degrees and reduce the noise created by the power transmission by approx. 3÷5 Db.

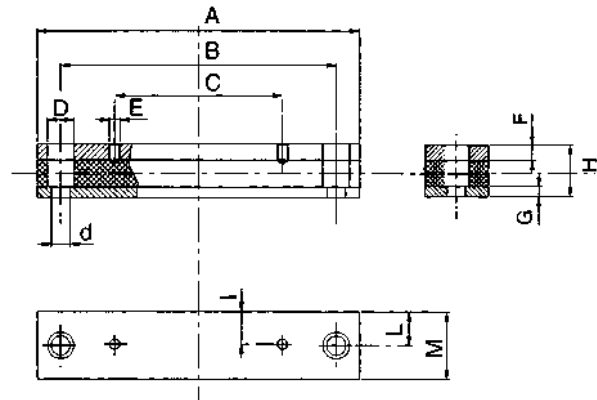

I codici presenti in tabella si riferiscono alla coppia di pattini / Indicated part-numbers refer to 2 pieces of damping rods

Codice / Part number (1 pair)	Dimensioni (mm) / Dimensions (mm)											
	A	B	C	D	d	E	F	G	H	I	L	M
BMA-P160-OMT	198	156	80	20	14	M8	12	8	40	21	26,5	53
BMA-P200-OMT	198	156	103	20	14	M8	12	8	40	24,5	26,5	53
BMA-P250-OMT	244	205	130	20	14	M10	12	8	40	24	26,5	53
BMA-P300-OMT	288	245	160	20	14	M12	12	8	40	20	26,5	53
BMA-P350-OMT	419	370	250	26	18	M14	15	15	60	28	36,5	73

BARRE AMMORTIZZANTI / DAMPING RODS

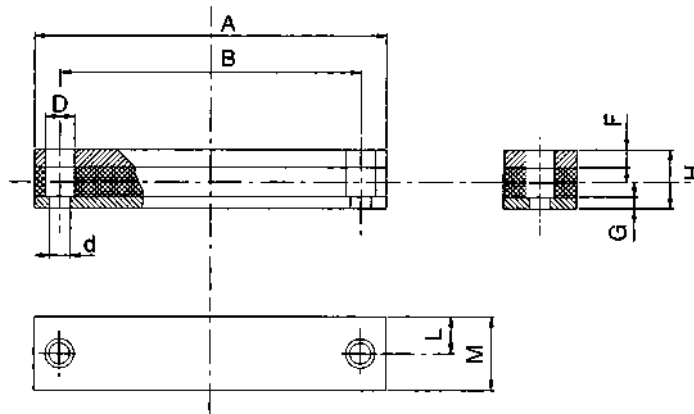
 tipo / series **BMA**

Codice / Part number (1 pair)	Tabella delle dimensioni (mm) / Dimensions (mm)									Taglie motori Motor size
	A	B	D	d	F	G	H	L	M	
BMA - 71	198	156	20	14	12	8	40	26,5	53	71;80;90
BMA - 90	244	205	20	14	12	8	40	26,5	53	90L;100L;112L
BMA - 132	288	245	20	14	12	8	45	26,5	53	132S;132M
BMA - 160 M	343	300	26	18	15	15	60	36,5	73	160M
BMA - 160 L	419	370	26	18	15	15	60	36,5	73	160L;180M
BMA - 180	446	400	26	18	15	15	60	36,5	73	180
BMA - 200	500	430	33	22	15	15	60	36,5	73	200L;225S
BMA - 225	500	445	33	22	15	15	60	36,5	73	225M
BMA - 250	500	445	33	22	15	15	60	51,5	103	250M
BMA - 280	618	570	33	22	15	15	60	51,5	103	280M;280S

BARRE AMMORTIZZANTI / DAMPING RODS

tipo / series **BMA - F**

con forature motore
with borings for standard motors

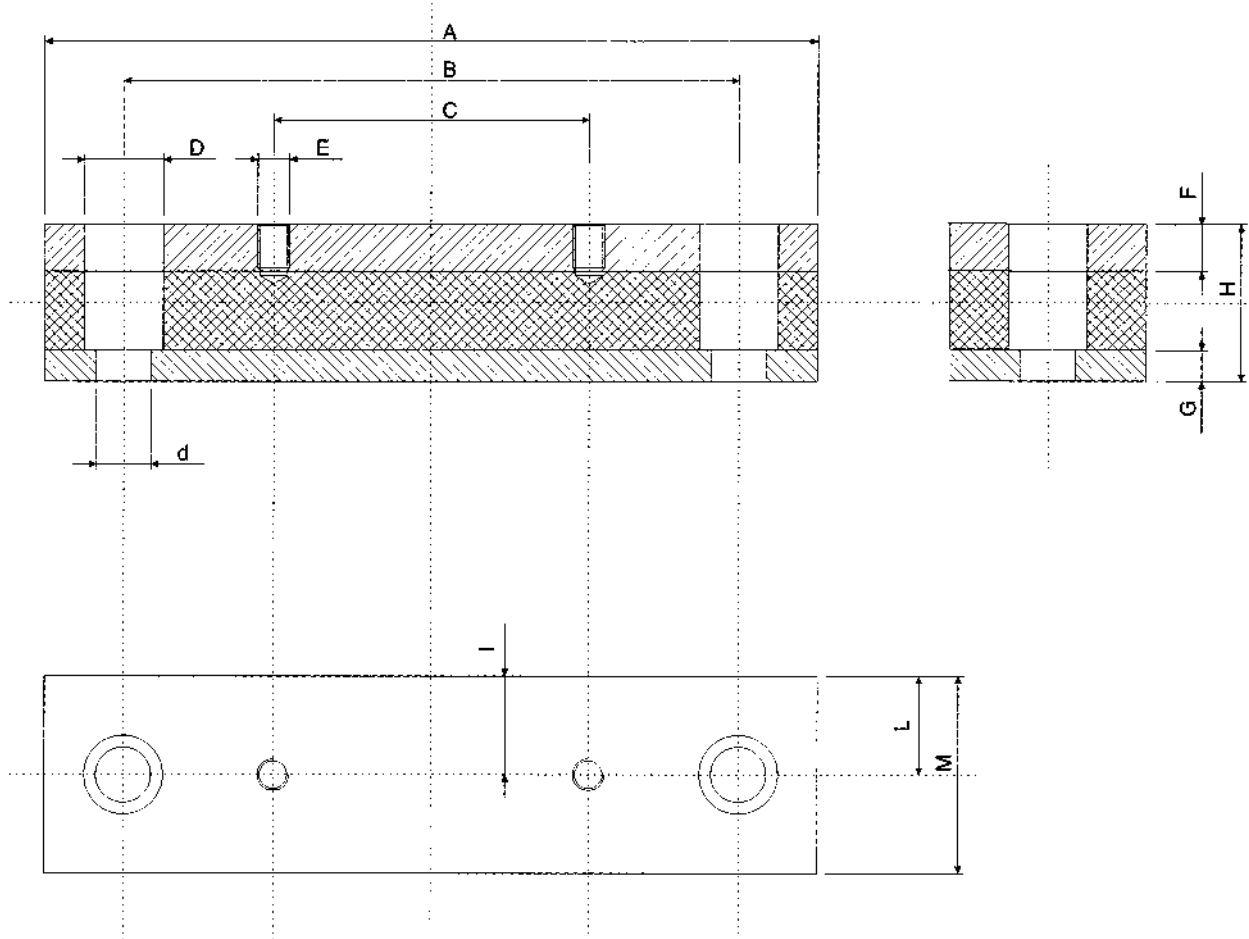

Codice Part number	Per motori taglia For motor size	Dimensioni (mm) / Dimensions (mm)											
		A	B	C	D	d	E	F	G	H	I	L	M
BMA - 71 - F	71	198	156	90	20	14	M6	12	8	40	21	26,5	53
BMA - 80 - F	80	198	156	100	20	14	M8	12	8	40	22	26,5	53
BMA - 90S - F	90S	198	156	100	20	14	M8	12	8	40	24,5	26,5	53
BMA - 90L - F	90L	244	205	125	20	14	M8	12	8	40	24	26,5	53
BMA - 100L - F	100L	244	205	140	20	14	M10	12	8	40	24	26,5	53
BMA - 112M - F	112M	244	205	140	20	14	M10	12	8	40	20	26,5	53
BMA - 132S - F	132S	288	245	140	20	14	M10	12	8	45	20	26,5	53
BMA - 132M - F	132M	288	245	178	20	14	M10	12	8	45	20	26,5	53
BMA - 160M - F	160M	343	300	210	26	18	M12	15	15	60	28	36,5	73
BMA - 160L - F	160L	419	370	254	26	18	M12	15	15	60	28	36,5	73
BMA - 180M - F	180M	419	370	241	26	18	M12	15	15	60	35	36,5	73
BMA - 180L - F	180L	446	400	279	26	18	M12	15	15	60	35	36,5	73
BMA - 200L - F	200L	500	430	305	33	22	M16	15	15	60	35	36,5	73
BMA - 225S - F	225S	500	430	286	33	22	M16	15	15	60	35	36,5	73
BMA - 225M - F	225M	500	445	311	33	22	M16	15	15	60	35	36,5	73
BMA - 250M - F	250M	500	445	349	33	22	M20	15	15	60	50	51,5	103
BMA - 280S - F	280S	618	570	368	33	22	M20	15	15	60	50	51,5	103
BMA - 280M - F	280M	618	570	419	33	22	M20	15	15	60	50	51,5	103