

Technical Information

Steering unit LAGC



OIL SOLUTIONS

PO Box 38

Strathfieldsaye, VIC, 3551

1800 OIL SOL

1800 645 765

sales@oilsolutions.com.au

www.oilsolutions.com.au

"For All Your Hydraulic Needs"

Contents

Chapter 1: Steering unit LAGC.....	5
Features.....	6
Ordering details.....	6
Function, section.....	9
Versions.....	10
Functions in a steering circuit.....	12
Technical data.....	14
Pressure fluid technical data.....	15
Calculating the steering moment.....	16
Defining the steering cylinder and steering pump.....	17
Unit dimensions type LAGC / LAGC LD / LAGC LDA.....	19
Ports: Type LAGC / LAGC LD / LAGC LDA.....	20

Chapter

1

Steering unit LAGC

Topics:

- *Features*
- *Ordering details*
- *Function, section*
- *Versions*
- *Functions in a steering circuit*
- *Technical data*
- *Pressure fluid technical data*
- *Calculating the steering moment*
- *Defining the steering cylinder and steering pump*
- *Unit dimensions type LAGC / LAGC LD / LAGC LDA*
- *Ports: Type LAGC / LAGC LD / LAGC LDA*

Features

- LAGC steering units are used in hydrostatic steering circuits of vehicles and mobile machines with large axle loads and travel speeds not exceeding 60 kph.
- With the aid of a steering unit even heavy vehicles can easily be steered. The absence of a mechanical connection between the steering unit and steering axle allows the designer to realize solutions, which would be impossible with conventional steering systems.
- The steering unit includes all valves required in the hydraulic steering circuit for the protection of the steering unit and the steering cylinder. This eliminates the need for additional pipework.
- If the oil supply to the steering unit fails, vehicles can also be steered manually with the help of the LAGC. In this case, the LAGC acts as hand pump for the steering cylinder.

Ordering details

The following table breaks down the ordering information for the LAGC steering unit. Each entry in the leftmost column provides a component of the ordering number, with a result similar to the following: "LAG|C|X|X|1x|X|X-X|M|X|*"

The symbol "●" refers to the standard program, while the symbol "⦿" refers to the extended program.

Part number	Description	Code
LAG	Steering unit	
C	Design With integrated values	= C

Part number	Description			Code
	Displacement volume (cm³/rev)			
		Nom. size	OC ; LD	R¹LDA²
		40	●	● = 40
		50	●	● = 50
		63	●	● = 63
		70	●	● = 70
		80	●	● = 80
		100	●	● = 100
		125	●	● = 125
		140	●	● = 140
		160	●	● = 160
		200	●	● = 200
		250	●	● = 250
		320	●	● = 320
		400	●	● = 400
		500	●	● = 500
		630	●	● = 630
		800	●	● = 800
	1000	●	● = 1000	
	Noise characteristics			
		Standard ³		= -
		low ⁴		= N

¹ With reaction

² Dynamic load signal for priority valve flanging on

³ To be used for all LD / LDA versions

⁴ To be used for Open Center (OC) versions

Part number	Description	Code
1x (/)	Component series	
	10 to 19	= 1x
	(10 to 19: unchanged installation and connection dimensions)	
	20 to 29	= 2x ⁵
	(20 to 29: Unchanged installation and connection dimensions)	
	Load sensing	
	Without load signal in open center (OC) version	● = no code
	Dynamic load signal	● = LD
	Dynamic load signal, priority valve can be flanged on	● = LDA
	Reaction	
without reaction	= no code	
with reaction	= R	
(-)	Shock valve setting⁶ (pressure differential)	
	150 bar	= 150
	200 bar	= 200
	240 bar	= 240
	Pressure relief valve setting⁵ (pressure differential)	
	90 bar	= 90
	140 bar	= 140
	175 bar	= 175
M	Seals Suitable for mineral oil (HL, HLP) to DIN 51524	= M

⁵ Only Open Center design (extended flow: see [Technical data](#) on page 14)

⁶ The pressure setting of shock valves must be 50 bar higher than the setting of the pressure relief valve, but not exceed 2.2 times the setting of the latter (see §38 StVZO, German Road Traffic Licensing Regulation). Preferably: 150 to 90; 200 to 140; 240 to 175.

Part number	Description	Code
	Pipe connections P, T, L, R/LD⁷	
	Pipe thread	● = 01
	Metric DIN thread	◐ = 02 / 40
	Metric ISO thread	◑ = 06
	SAE thread	◒ = 12 / 19
*	<i>Special specifications. Please clarify with our sales organization.</i>	

Function, section

Control spool (1) of the control valve is rotated via the steering column in relation to control sleeve (2). This opens cross-sections between the spool and the sleeve. The pressurised oil acts on the rotor set (3) and sets the latter into motion. The oil is then fed via the rotor set to the steering cylinder. The rotation of the rotor acts on the sleeve, which then follows the rotary movement of the spool.

The size of the opened cross-section depends on the turning speed of the steering wheel and on the steering pressure, on Load-Sensing versions it depends exclusively on the turning speed.

If the steering movement is interrupted and the spool is at a standstill, the oil, which still flows through the opened cross-sections to the rotor, causes the rotor and hence the sleeve to continue to rotate a bit.

The rotary movement then causes the cross-section to close now, the rotor also comes to a standstill and at the same time the steering cylinder is in the desired position. The centering spring (4) brings and holds the spool and sleeve in a neutral position to each other.

The pressure relief valve (5) limits the system pressure of the steering circuit. On the Load-Sensing versions, the pilot pressure relief valve for the load signal is installed instead (see sectional drawing).

Two anti shock valves (6) protect the ports L and R to the steering cylinder. If one of the anti shock valves opens, the discharged oil is fed via an anti-cavitation valve (7) to the opposite side, or missing oil will be sucked from the tank.

In the event of an oil supply failure, the LAGC operates as hand pump. In this operational state, oil can be sucked from the tank via the suction check valve (8), the inlet check valve (9) prevents that air gets into the P-port (P).

During normal operation, this valve prevents shock or kick backs on the steering wheel caused by excessive external steering forces.

⁷ For thread dimensions see [Unit dimensions type LAGC / LAGC LD / LAGC LDA](#) on page 19.

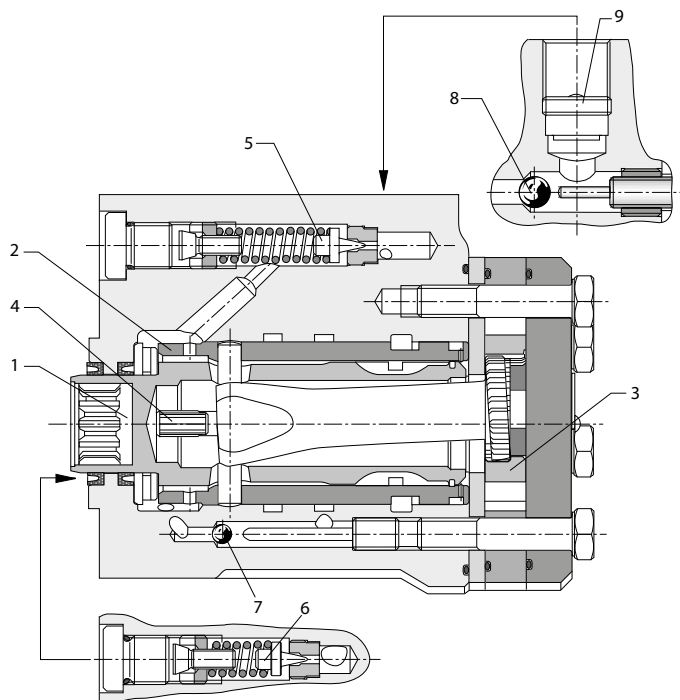

- | | |
|---|-----------------------|
| 1 | Control spool |
| 2 | Control sleeve |
| 3 | Rotor set |
| 4 | Centering spring |
| 5 | Pressure relief valve |
| 6 | Anti shock valve |
| 7 | Anti-cavitation valve |
| 8 | Suction check valve |
| 9 | Inlet check valve |

Figure 1: Cross section LAGC

Versions

Standard version

Open Center with Non Reaction = OC / NR

Mainly used in steering systems with fixed displacement hydraulic pumps.

When no steering movement is performed, the connection between pump port (P) and tank port (T) is open (OC), and the pump flow is directed to the tank almost at zero pressure. Ports L¹ (left) and R¹ (right) are blocked in the neutral position (NR). In this way, external forces acting via the steering cylinder are supported without the driver perceiving any resulting reaction forces on the steering wheel (Non Reaction).

¹ Contrary to standardization, the actuator lines in steering systems are usually designated “L” and “R”, not “A” and “B”.

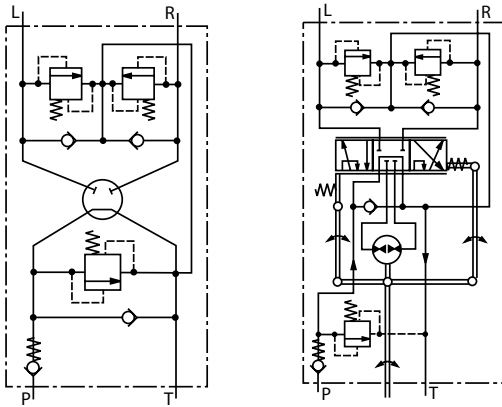

Figure 2: LAGC OC / NR

Standard version

Open Center with Reaction = OC / R

In the neutral position, the cylinder ports are connected with each other. External forces acting via the steering cylinder are perceived as reaction force by the driver on the steering wheel (Reaction). When the driver releases the steering wheel after the steering maneuver is completed, the wheels and the steering wheel automatically return to straight-ahead travel, provided that the steering geometry is suitable for this.

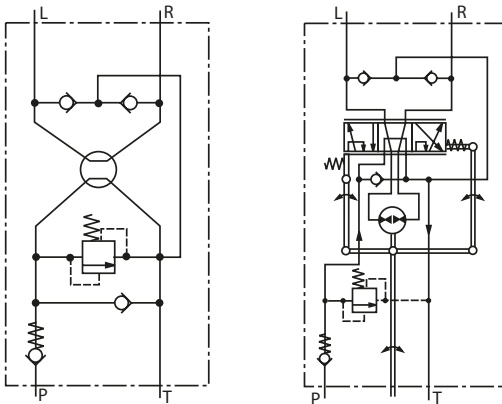

Figure 3: LAGC OC / R

Low-noise version

Steering units of the LAGC Open Center versions are generally delivered in the low-noise variant “N”.

Load sensing version

Steering units with load sensing provide a load signal that can be used to control a priority valve and/or a pump. They are designed as closed center steering systems whereby the connection pump (P) to tank (T) is locked while neutral position.

If the steering and implement hydraulics are supplied by a common pump then the use of a priority valve is necessary. The priority valve ensures that the steering unit gets a priority oil supply, whereby the control of the priority valve runs via the steering unit load signal. When steering is not operating then the entire oil flow from the pump is made available to the implement hydraulics. Fixed or variable displacement pumps can be used.

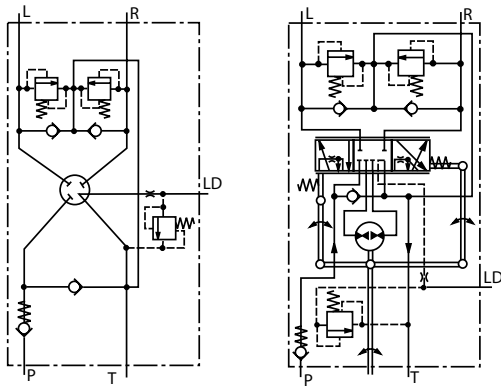

Figure 4: LAGC LD / NR

Load signal, dynamic

There is always a recommended oil flow of approx. 0.5 - 1.0 l/min in the LS-line from the priority valve to the steering unit that transmits the load (pressure) signal from the steering unit to the priority valve. Consequently, the steering unit gets warmed up by this and has approximately the same temperature as the oil.

Thermal shocks are largely prevented.

The LD variant causes the priority valve to react faster. The hard point at the beginning of the steering movement is usually no longer perceivable - even under cold start conditions.

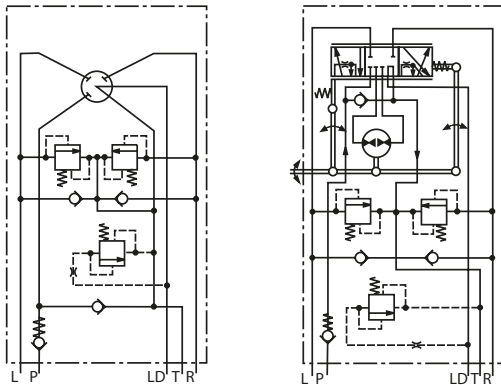

Figure 5: LAGC LDA / NR

Flanged-on priority valve

Steering units with a flanged-on priority valve significantly reduce the piping effort.

Functions in a steering circuit

Power-assisted mode - Servo operation

Steering units of type LAGC consist of a manually operated rotary spool valve, one rotor set, which operates according to the gerotor principle, and the required valves for the steering circuit.

The nominal size for the power-assisted mode results of the rotor set size. The size of the rotor set is to be selected so that with 3 to 5 turns of the steering wheel it gets possible to steer from lock to lock.

Manual steering - Emergency mode

During normal operation of the steering unit, when a sufficient amount of oil gets supplied to the steering unit, the torque required on the steering wheel is < 5 Nm. In the event that the oil supply fails, the steering unit operates in the emergency mode. The required steering pressure must then be generated by manual force on the steering wheel.

For emergency operation, the size must be selected so that legal requirements with regard to the maximum manual force limits are complied with.

Pressure relief valve

The pressure relief valve for the hydraulic pump is available in three standard pressure settings:

- 90 bar
- 140 bar
- 175 bar

Other settings are possible on request.

Anti shock valves

The cylinder side valves that are built into the LAGC unit are available in three standard pressure settings:

- 150 bar
- 200 bar
- 240 bar

Other settings are possible on request.

Note: The pressure in the T line increases the set pressure by the equivalent value

Anti cavitation valves L and R

In the event of a negative pressure in the steer cylinder lines oil can be sucked from the T- area via the anti cavitation valves.

Suction check valves T to P

If the hydraulic pump fails then the pressure fluid is drawn from the reservoir via this valve, which is fitted between the P and T connections.

Inlet check valve

The check valve of the P-port prevents the return flow of oil from the steer cylinder - due to external forces working onto the steer cylinder - into the hydraulic system. So it prevents kick back turning of the steering wheel.

While manual steering it prevents sucking air from the P-port.



Caution:

The emergency operating mode is not intended for continuous operation! If a higher pressure is required for steering in emergency operation at 70 Nm, a steering unit with automatic displacement reduction, LAGU, OSPU, LAGZ or OSPD can be installed.

During manual steering, the following pressures can be achieved in dependence upon the steering moment:

M_{steer}	Nom. size	040	050	063	070	080	100	125	140	160
120 Nm	p in bar	90	90	85	82	80	60	50	45	40
70 Nm	p in bar	56	56	50	48	46	35	30	27	23

M_{steer}	Nom. size	200	250	320	400	500	630	800	1000	
120 Nm	p in bar	30	25	20	15	12	10	7	4	
70 Nm	p in bar	17	14	11	8	7	6	4	2	

Technical data

Table 1: General

Ambient temperature range	ϑ	°C	-20 to +80
Steering moment - standard ¹	M	Nm	≤ 5
Steering moment - emergency operation	M	Nm	≤ 160 permissible
Max. tightening torque M_A for the mounting screws		Nm	30 (see HE 11874 "steering column")

Table 2: Hydraulic

Nominal pressure	p	bar	175			
Pressure fluid	See Pressure fluid technical data on page 15					
Pressure fluid temperature range	ϑ	°C	-20 to +80			
Viscosity range	ν	mm ² /s	10 to 800			
max. permissible degree of contamination of the pressure fluid is to ISO 4406 (c)			class 19/16/13 ²			
Steering unit type	Displacement volume servo operation cm ³	Flow		max. perm. pressure in port		
		Nom ³ l/min	max l/min	P bar	T bar	L and R bar
LAGC 40	40	4.0	15	175	20	240
LAGC 50	50	5.0	15	175	20	240
LAGC 63	63	6.3	20	175	20	240
LAGC 70	70	7.0	25	175	20	240
LAGC 80	80	8.0	25	175	20	240
LAGC 100	100	10.0	30	175	20	240
LAGC 125	125	12.5	35	175	20	240
LAGC 140	140	14.0	35	175	20	240

¹ Other steering moment variants (e. g. low) on request

² The cleanliness classes specified for components must be adhered to in hydraulic systems. Effective filtration prevents malfunction and, at the same time, prolongs the service life of components.

³ **Related to the steering speed of 100 steering rotations/min.**

Steering unit type	Displacement volume servo operation cm ³	Flow		max. perm. pressure in port		
		Nom ³ l/min	max l/min	P bar	T bar	L and R bar
LAGC 160	160	16.0	50	175	20	240
LAGC 200	200	20.0	50	175	20	240
LAGC 250	250	25.0	50	175	20	240
LAGC 320	320	32.0	50	175	20	240
LAGC 400	400	40.0	50	175	20	240
LAGC 500	500	50.0	50	175	20	240
LAGC 630	630	63.0	50	175	20	240
LAGC 800	800	80.0	80	175	20	240
LAGC 1000	1000	80.0	80 ⁴	175	20	240

Pressure fluid technical data

Pressure fluids

Before carrying out any engineering please refer to the extensive information regarding pressure fluid selection and application conditions in standards or manufacturer instructions. For pressure fluids that require FKM or other seals please contact your sales contact.

Operating viscosity

We recommend that the operating viscosity (at operating temperature) for efficiency and service life, is selected within the optimum range of

v_{opt} = optimum operating viscosity range 16 to 46 mm²/s

with reference to the temperature.

Limiting viscosity

For the limiting conditions the following values apply:

- v_{min} = 10 mm²/s at a max. permissible temperature of ϑ_{max} = + 80 °C
- v_{max} = 800 mm²/s

Temperature range (see selection diagram)

- ϑ_{min} = - 20 °C
- ϑ_{max} = + 80 °C

If there is the possibility of there being a temperature difference of more than 20 °C between the steering unit and the pressure fluid, then either a LD or LDA version or an open center version for warming the steering unit should be fitted.

³ Related to the steering speed of 100 steering rotations/min.

⁴ Design related is the flow rate limited onto 80 l/min of the LAGC1000.

Further on the selection of pressure fluids

A prerequisite to being able to select the correct pressure fluid is knowing the operating temperature and the ambient temperature. The pressure fluid should be so selected that the operating viscosity at the working temperature lies within the optimum range (see selection diagram). We recommend that the next higher viscosity class is selected.

Example:

For an ambient temperature of X °C the tank temperature stabilises at 60 °C. To achieve the optimum viscosity, this relates to the viscosity classes of VG 46 or VG 68; → VG 68 should be selected.

Pressure fluid filtration

The finer the filtration the higher the cleanliness class of the pressure fluid is achieved and so the higher the service life of the entire hydraulic system.

Note: To ensure the functionality of the steering pump a minimum pressure fluid cleanliness class of 19 / 16 / 13 to ISO 4406 is necessary (see [Technical data](#)).



Caution: Operating the unit with contaminated hydraulic fluid may lead to the steering system failing.

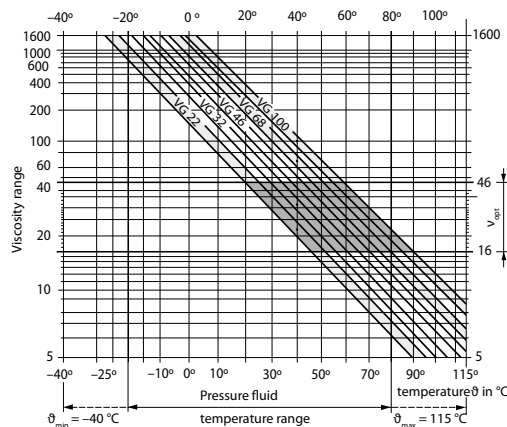

Figure 6: Selection diagram

Calculating the steering moment

Table 3: Formula symbols

Formula symbol	Designation	Unit
A	Required cylinder area	mm ²
A ₁	Cylinder piston area, differential cylinder	mm ²
A ₂	Cylinder ring area, differential cylinder	mm ²
b	Tyre width	mm
d	Piston rod diameter	mm
D	Cylinder diameter	mm
e	Distance of swivel bearing to center of tire	mm
F	Steering force	N
F _A	Steering axle force	N

Formula symbol	Designation	Unit
h	Cylinder stroke length	mm
i	No. of steering wheel turns	
l	Smallest, effective steering lever	mm
M	Steering moment	Nm
n	Steering wheel rotational speed	min ⁻¹
n _{leer}	Motor idling RPM	min ⁻¹
n _{Motor}	Motor operating RPM	min ⁻¹
p	Steering pressure	bar
q _{vp}	Pump flow	l/min
V	Steering unit displacement	cm ³ /U
V _p	Steering pump displacement	cm ³ /U
V _{ZYL}	Cylinder volume	cm ³
μ	Co-efficient of friction	

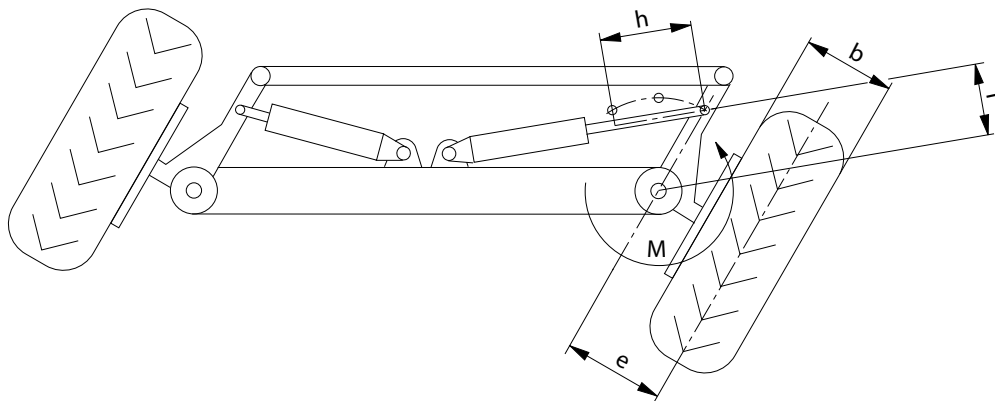

Figure 7: Steering geometry

$$M = 0,05 \cdot F_A \cdot \frac{1}{1 + \frac{e}{b}} \cdot \frac{b}{200} \cdot \frac{\mu}{0,7} \text{ [Nm]}$$

Figure 8: Steering moment

$$F = \frac{M}{l} \cdot 10^3 \text{ [N]}$$

Figure 9: Steering force

Defining the steering cylinder and steering pump

Steering cylinder

$$A = \frac{F}{p} \cdot 10 \text{ [mm}^2\text{]}$$

Figure 10: Required cylinder area

$$A_1 = \frac{\pi}{4} \cdot D^2 \quad [\text{mm}^2]$$

Figure 11: Cylinder area (piston side)

$$A_2 = \frac{\pi}{4} \cdot (D^2 - d^2) \quad [\text{mm}^2]$$

Figure 12: Cylinder area (rod side)

When using a differential or double roded cylinder, A_2 must be greater than the required cylinder area.

If two cross connected differential cylinders are to be used, then $A_1 + A_2$ must be greater than the required cylinder area.

The nominal size of steering unit results from the cylinder volume and the required number of steering wheel turns.

$$V_{zyl} = \frac{A \cdot h}{10^3} \quad [\text{cm}^3]$$

Figure 13: Cylinder volume

$$V = \frac{V_{zyl}}{i} \quad [\text{cm}^3/\text{U}]$$

Figure 14: Displacement volume LAGC

Normaly there are 3 to 5 turns of the steering wheel from end stop to end stop.

Steering pump

The pump should be so selected that when the motor is idling, a steering velocity of approx. 50 min^{-1} can still be achieved. The maximum steering speed, which is dependent on the steering wheel diameter, is approx. 100 to 150 min^{-1} .

Volume flow of the pump $q_{vp} = V \cdot (n + 10) \cdot 10^{-3} \text{ l/min}$.

The pump displacement ($\hat{=}$ normal size) required for steering at idling speed and at operating speed of the vehicle must be calculated.

$$V_p = \frac{q_{vp} \cdot 10^3}{n_{leer}} \quad [\text{cm}^3/\text{U}]$$

Figure 15: Pump size at idling speed

$$V_p = \frac{q_{vp} \cdot 10^3}{n_{Motor}} \quad [\text{cm}^3/\text{U}]$$

Figure 16: Pump size at operating speed

Unit dimensions type LAGC / LAGC LD / LAGC LDA

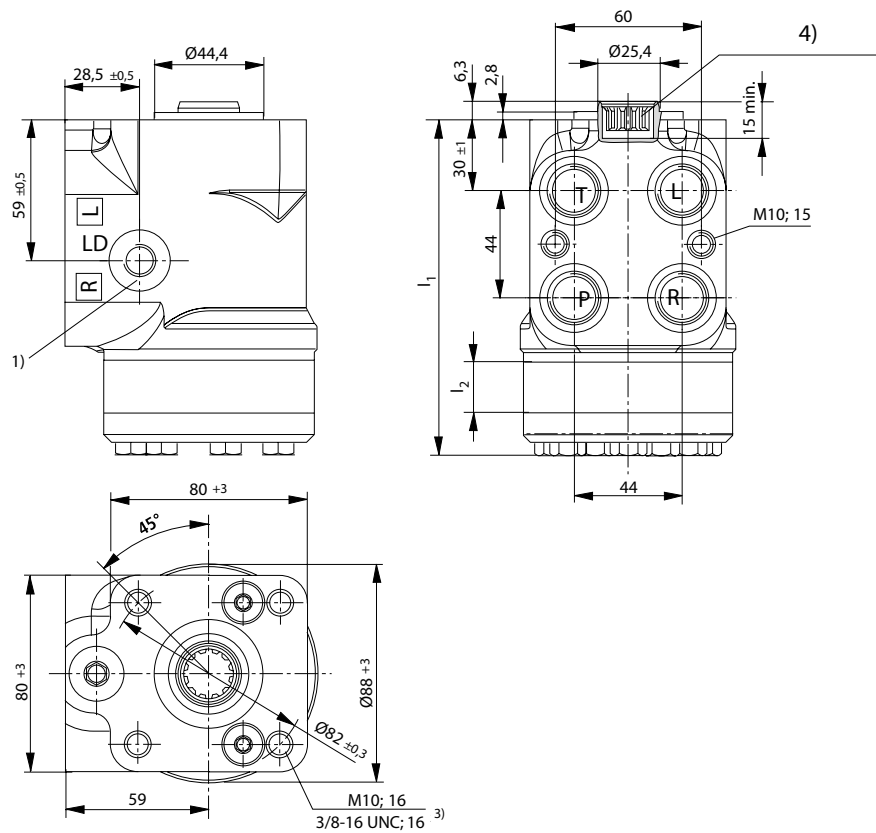

Figure 17: Dimensions in mm

Nom. size	l
40	124
50	125
63	127
70	128
80	129
100	132
125	135
140	137
160	139
200	145
250	151
320	161
400	172
500	186

Nom. size	l
630	202
800	223
1000	253

Ports: Type LAGC / LAGC LD / LAGC LDA

(dimensions in mm)

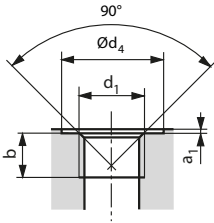

Figure 18: Imperial, metric thread

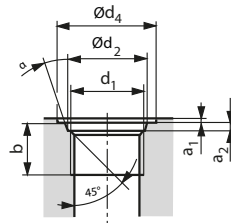

Figure 19: UNF, metric thread

Table 4:

Port	Version	d ₁	Ød ₂	Ød ₄	b _{min.}	a ₁	a ₂	α
P, T, L, R	01	G 1/2	-	28 ^{+0.4}	14	max. 0.2	-	-
	02	M22 x 1.5	-	28 ^{+0.4}	14	max. 0.2	-	-
	06	M18 x 1.5	19.8 ^{+0.1}	29 ^{+0.4}	14.5	max. 0.2	2.4 ^{+0.4}	15° ±1°
	12 / 19	¾-16 UNF	20.6 ^{+0.1}	30 ^{+0.5}	14.3	max. 0.2	2.4 ^{+0.4}	15° ±1°
	40 ¹	M18 x 1.5	-	25 ^{+0.5}	12	max. 0.2	-	-
LD	01	G 1/4	-	25 ^{+0.4}	12	1±0.5	-	-
	02	M12 x 1.5	-	25 ^{+0.4}	12	1±0.5	-	-
	06	M12 x 1.5	13.8 ^{+0.1}	25 ^{+0.4}	11.5	1±0.5	2.4 ^{+0.4}	15° ±1°
	12 / 19	7/16-20 UNF	12.4 ^{+0.1}	21 ^{+0.5}	11.5	1±0.5	2.3 ^{+0.4}	12° ±1°
	40 ¹	M12 x 1.5	-	25 ^{+0.4}	12	1±0.5	-	-

Standards for hydraulic port dimensions:

01	DIN 3852-2 Form X
02	DIN 3852-1 Form X
06	ISO 6149-1
12	SAE J514
19	SAE J514
40	DIN 3852-1 Form X

¹ The LAGC...LDA.. version has generally ports according to code "40."