

Technical Information

Steering Unit LAGU



OIL SOLUTIONS

PO Box 38

Strathfieldsaye, VIC, 3551

1800 OIL SOL

1800 645 765

sales@oilsolutions.com.au

www.oilsolutions.com.au

"For All Your Hydraulic Needs"

Contents

Chapter 1: Steering Unit LAGU Technical Information.....	5
Features.....	6
Ordering details.....	6
Function, section.....	8
Versions.....	9
Functions in a steering circuit.....	12
Technical data.....	13
Pressure fluid technical data.....	14
Calculating the steering moment.....	15
Defining the steering cylinder and steering pump.....	16
Dimensions LAGU / LAGU LD / LAGU LDA.....	18
Ports LAGU / LAGU LD / LAGU LDA.....	19

Chapter

1

Steering Unit LAGU Technical Information

Topics:

- *Features*
- *Ordering details*
- *Function, section*
- *Versions*
- *Functions in a steering circuit*
- *Technical data*
- *Pressure fluid technical data*
- *Calculating the steering moment*
- *Defining the steering cylinder and steering pump*
- *Dimensions LAGU / LAGU LD / LAGU LDA*
- *Ports LAGU / LAGU LD / LAGU LDA*

Features

- The LAGU steering unit is used in hydraulic steering circuits on vehicles and mobile machines that have high axle loads and maximum travel speeds of 60 kph.
- With the aid of a steering unit even heavy vehicles can be easily steered. The absence of a mechanical connection between the steering unit and steering axle allows the designer to realize solutions, which would be impossible with conventional steering systems.
- If the oil supply to the steering unit fails, vehicles can easier be steered manually with the help of the LAGU. The LAGU acts also as a hand pump but the driving torque from the steering wheel gets reduced by changing the displacement ratio onto the half. Only due to this, in many cases, are the permissible limiting values complied with. In many applications a backup steering pump is no longer necessary.
- The LAGU works on the principal of switching off rotor set chambers. It acts with the full rotor set displacement without any ratio changes in servo mode.

Ordering details

The following table breaks down the ordering information for the LAGU steering unit. Each entry in the leftmost column provides a component of the ordering number, with a result similar to the following: "LAG|U|X|X|1x/X|X|X-X|M|X|*"

The symbol "●" refers to the standard program, while the symbol "⦿" refers to the extended program.

Part number	Description	Code		
LAG	Steering unit			
U	Design with step-down ratio	=U		
	Displacement volume (cm³/rev) Servo operation / emergency operation			
		Nom. size	OC ; LD	R¹LDA²
		100 / 50	⦿	⦿
		125 / 60	●	●
		140 / 70	⦿	⦿
		160 / 80	●	●
		180 / 90	⦿	⦿
		200 / 100	●	●
		250 / 125	●	
		320 / 160	●	
	Noise characteristics			
		Standard ³	= -	
		low ⁴	= N	

¹ With reaction

² Dynamic load signal for priority valve flanging on

³ To be used for LD / LDA versions

⁴ Only with the open center (OC) version

Part number	Description	Code
1x (/)	Component series	
	10 to 19	= 1x
	(10 to 19: unchanged installation and connection dimensions)	
	Load sensing without load signal in open center	
	(OC) version	= no code
	dynamic load signal	● = LD
	dynamic load signal, priority valve can be flanged on	● = LDA
	Reaction	
	without reaction	= no code
	with reaction	= R
(-)	Shock valve setting⁵ (pressure differential)	
	150 bar	= 150
	200 bar	= 200
	240 bar	= 240
	260 bar	= 260
	Pressure relief valve setting⁵ (pressure differential)	
	90 bar	= 90
	140 bar	= 140
	175 bar	= 175
	210 bar	= 210
M	Seals NBR seals, suitable for mineral oil (HL, HLP) to DIN 51524, low torque.	= M

⁵ The response pressure of the shock valves must be 50 bar higher, however a maximum of 2.2 times that of the hydraulic pump pressure relief valves. (see §38 StVZO, German Road Traffic Licensing Regulation) Preferably 150 to 90; 200 to 140; 240 to 175 bar.

Part number	Description	Code
	Pipe connections P, T, L, R/LD⁶	
	Pipe thread	● = 01
	Metric DIN thread	◐ = 02 / 40
	Metric ISO thread	◑ = 06
	SAE thread	◒ = 12 / 19
*	<i>Special specifications. Please clarify with our sales organization.</i>	

Function, section

Control spool (1) of the control valve is rotated via the steering column in relation to control sleeve (2). This opens cross-sections between the spool and the sleeve. The pressurised oil acts on the rotor set (3) and sets the latter into motion. The oil is then fed via the rotor set to the steering cylinder. The rotation of the rotor acts on the sleeve, which then follows the rotary movement of the spool.

The size of the opened cross-section depends on the turning speed of the steering wheel and on the steering pressure, on Load-Sensing versions it depends exclusively on the turning speed.

If the steering movement is interrupted and the spool is at a standstill, the oil, which still flows through the opened cross-sections to the rotor, causes the rotor and hence the sleeve to continue to rotate a bit.

The rotary movement then causes the cross-section to close now, the rotor also comes to a standstill and at the same time the steering cylinder is in the desired position. The centering spring (4) brings and holds the spool and sleeve in a neutral position to each other.

The pressure relief valve (5) limits the system pressure of the steering circuit. On the Load-Sensing versions, the pilot pressure relief valve for the load signal is installed instead (see sectional drawing).

Two anti shock valves (6) protect the ports L and R to the steering cylinder. If one of the anti shock valves opens, the discharged oil is fed via an anti-cavitation valve (7) to the opposite side, or missing oil will be sucked from the tank.

In the event of an oil supply failure, the LAGU operates as hand pump. In this case, via the cylinder pressure, the cut-off valve (10) opens and a specific number of displacement chambers are connected with the return (switched off). The check valves (11) and (12) prevent a connection from the switched off to the working rotor set chambers.

The displacement volume of the rotor set is therefore reduced by the volume of the switched off chambers.

In this (hand pump) state, oil can be sucked from the tank via the suction check valve (8), the inlet check valve (9) prevents that air gets into the P-port (P). During normal operation, this valve prevents shock or kick backs on the steering wheel caused by excessive external steering forces.

⁶ For thread dimensions see [Dimensions LAGU / LAGULD / LAGULDA](#) on page 18

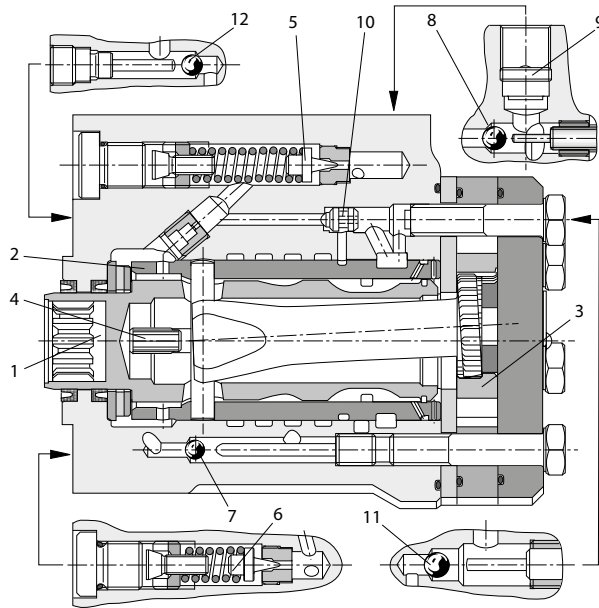

Figure 1: Cross Section LAGU

- | | |
|----|-----------------------|
| 1 | Control spool |
| 2 | Control sleeve |
| 3 | Rotor set |
| 4 | Centering spring |
| 5 | Pressure relief valve |
| 6 | Anti-shock valve |
| 7 | Anti-cavitation valve |
| 8 | Suction check valve |
| 9 | Inlet check valve |
| 10 | Cut-off valve |
| 11 | Check valve |
| 12 | Check valve |

Versions

Standard version | Open Center with Non Reaction = OC / NR

Mainly used in steering systems with fixed displacement hydraulic pumps (e.g. gear pumps).

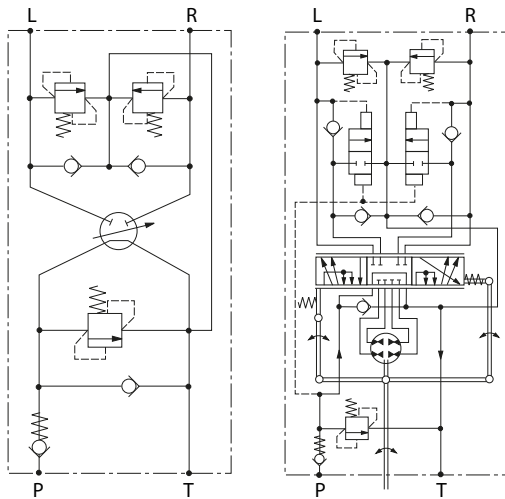

Figure 2: LAGU OC / NR schematic

When no steering movement is performed, the connection between pump port (P) and tank port (T) is open (OC), and the pump flow is directed to the tank almost at zero pressure. Ports L¹ (left) and R¹ (right) are blocked in the neutral position (NR). In this way, external forces acting via the steering cylinder are supported without the driver perceiving any resulting reaction forces on the steering wheel (Non Reaction).

Note: Steering units for vehicles with a articulated steering or with rear axle steering must always use the NR version.

Standard version | Open Center with Reaction = OC / R

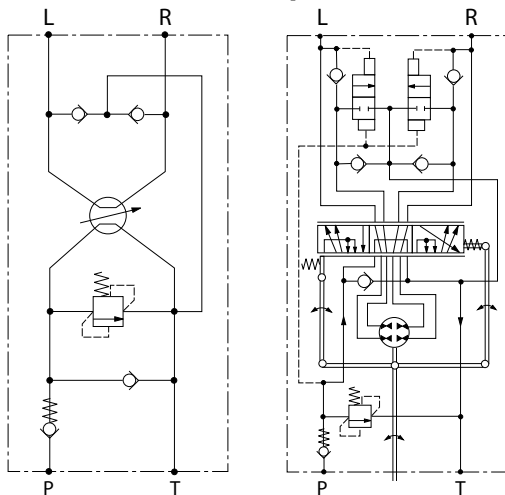

Figure 3: LAGU OC / R schematic

In the neutral position, the cylinder ports are connected with each other. External forces acting via the steering cylinder are perceived as reaction force by the driver on the steering wheel (Reaction). When the driver releases the steering wheel after the steering maneuver is completed, the wheels and the steering wheel automatically return to straight-ahead travel, provided that the steering geometry is suitable for this.

Low-noise version

Steering units of the LAGU Open Center versions are generally delivered in the low-noise variant “N”.

¹ Contrary to standardization, the actuator lines in steering systems are usually designated “L” and “R”, not “A” and “B”.

Load sensing version

Steering units with load sensing provide a load signal that can be used to control a priority valve and/or a pump. They are designed as closed center steering systems whereby the connection pump (P) to tank (T) is locked while neutral position.

If the steering and implement hydraulics are supplied by a common pump then the use of a priority valve is necessary. The priority valve ensures that the steering unit gets a priority oil supply, whereby the control of the priority valve runs via the steering unit load signal. When steering is not operating then the entire oil flow from the pump is made available to the implement hydraulics. Fixed or variable displacement pumps can be used.

Load signal, dynamic

There is always a recommended oil flow of approx. 0.5 - 1.0 l/min in the LS-line from the priority valve to the steering unit that transmits the load (pressure) signal from the steering unit to the priority valve. Consequently, the steering unit gets warmed up by this and has approximately the same temperature as the oil.

Thermal shocks are largely prevented.

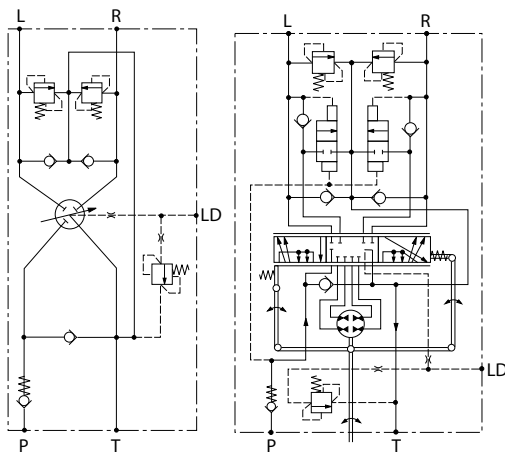

Figure 4: LAGU LD / NR schematic

The LD variant causes the priority valve to react faster. The hard point at the beginning of the steering movement is usually no longer perceivable - even under cold start conditions.

Flanged-on priority valve

Steering units with a flanged-on priority valve significantly reduce the piping effort.

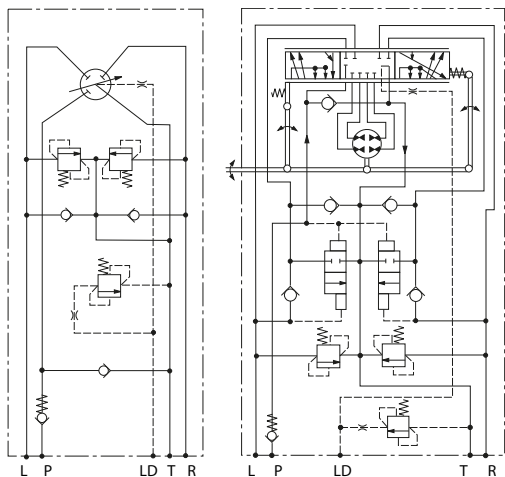

Figure 5: LAGU LDA / NR schematic

Functions in a steering circuit

Power-assisted mode - Servo operation

Steering units of type LAGU consist of a manually operated rotary spool valve, one rotor set, which operates according to the gerotor principle, and the required valves for the steering circuit.

The nominal size for the power-assisted mode results of the rotor set size. The size of the rotor set is to be selected so that with 3 to 5 turns of the steering wheel it gets possible to steer from lock to lock.

Manual steering - Emergency mode

During normal operation of the steering unit, when a sufficient amount of oil gets supplied to the steering unit, the torque required on the steering wheel is < 5 Nm. In the event that the oil supply fails, the steering unit operates in the emergency mode. The required steering pressure must then be generated by manual force on the steering wheel.

For emergency operation, the size must be selected so that legal requirements with regard to the maximum manual force limits are complied with.

The LAGU offers an automatic displacement reduction (stepdown ratio) by switching off displacement chambers of the rotor set while manual steering. The cut-off valve, that is closed during servo operation, is opened during emergency operation via the cylinder pressure and connects half of the displacement chambers to the return. The displacement volume of the rotor set is therefore, reduced by a volume of 2:1.

The manually generated pressure is doubled as is the number of turns of the steering wheel.

Pressure relief valve

The pressure relief valve for the hydraulic pump is available in four standard pressure settings:

- 90 bar
- 140 bar
- 175 bar
- 210 bar

Other settings are possible on request.

Anti shock valves

The cylinder side valves that are built into the LAGU unit are available in four standard pressure settings:

- 150 bar
- 200 bar
- 240 bar
- 260 bar

Other settings are possible on request.

Note: The pressure in the T line increases the set pressure by the equivalent value.

Note: The setting of the anti shock valves must be approximately 50 bar higher than the pressure relief setting.

Anti cavitation valves L and R

In the event of a negative pressure in the steer cylinder lines oil can be sucked from the T- area via the anti cavitation valves.

Suction check valve T to P

If the hydraulic pump fails then the pressure fluid is drawn from the reservoir via this valve, which is fitted between the P and T connections.

Inlet check valve

The check valve of the P-port prevents the return flow of oil from the steer cylinder - due to external forces working onto the steer cylinder - into the hydraulic system. So it prevents kick back turning of the steering wheel. While manual steering it prevents sucking air from the P-port.



Caution: The emergency operating mode is not intended for continuous operation! If a higher pressure is required for steering in emergency operation at 70 Nm, a steering unit with automatic displacement reduction, OSPU, OSPD, or LAGZ, can be installed.

During manual steering with 50 or 70 Nm and a rotational speed of 20 min⁻¹ it is possible to achieve the following pressures:

M _{steer}	Nom. size	100 / 50	125 / 60	140 / 70	160 / 80	180 / 90	200 / 100	250 / 125	320 / 160
50 Nm	p in bar	40	37	33	30	27	24	18	12
70 Nm	p in bar	40	40	40	40	36	33	25	17

Technical data

For applications outside these parameters, please consult your service representative!

Table 1: General

Ambient temperature range	ϑ	°C	-20 to +80
Steering moment - standard ¹	M	Nm	≤ 5
Steering moment - emergency operation	M	Nm	≤ 160 permissible
Max. tightening torque M _A for the mounting screws		Nm	30

Table 2: Hydraulic

Pressure fluid	See <i>Pressure fluid technical data</i> on page 14		
Pressure fluid temperature range	ϑ	°C	-20 to +80
Viscosity range	v	mm ² /s	10 to 800
max. permissible degree of contamination of the pressure fluid is to ISO 4406 (c)	class 19/16/13 ²		

¹ Other steering moment variants (e. g. low) on request

² The cleanliness classes specified for components must be adhered to in hydraulic systems. Effective filtration prevents malfunction and, at the same time, prolongs the service life of components.

Steering unit Type	Displacement-volume Servo operation cm ³	Displacement-volume Emergency operation cm ³	Flow	
			Nom l/min ³	Max. l/min
LAGU 100 / 50	100	50	10.0	30
LAGU 125 / 60	125	60	12.5	35
LAGU 140 / 70	140	70	14.0	35
LAGU 160 / 80	160	80	16.0	50
LAGU 180 / 90	180	90	18.0	50
LAGU 200 / 100	200	100	20.0	50
LAGU 250 / 125	250	125	25.0	50
LAGU 320 / 160	320	160	32.0	50

Pressure fluid technical data

Pressure fluids

Before carrying out any engineering please refer to the extensive information regarding pressure fluid selection and application conditions in standards or manufacturer instructions. For pressure fluids that require FKM or other seals please contact your sales contact.

Operating viscosity

We recommend that the operating viscosity (at operating temperature) for efficiency and service life, is selected within the optimum range of

$$v_{opt} = \text{optimum operating viscosity range } 16 \text{ to } 46 \text{ mm}^2/\text{s}$$

with reference to the temperature.

Limiting viscosity

For the limiting conditions the following values apply:

- $v_{min} = 10 \text{ mm}^2/\text{s}$ at a max. permissible temperature of $\vartheta_{max} = + 80 \text{ }^\circ\text{C}$
- $v_{max} = 800 \text{ mm}^2/\text{s}$

Temperature range (see selection diagram)

- $\vartheta_{min} = - 20 \text{ }^\circ\text{C}$
- $\vartheta_{max} = + 80 \text{ }^\circ\text{C}$

If there is the possibility of there being a temperature difference of more than 20 °C between the steering unit and the pressure fluid, then either a LD or LDA version or an open center version for warming the steering unit should be fitted.

Further on the selection of pressure fluids

A prerequisite to being able to select the correct pressure fluid is knowing the operating temperature and the ambient temperature. The pressure fluid should be so selected that the operating viscosity at the working temperature lies within the optimum range (see selection diagram). We recommend that the next higher viscosity class is selected.

³ Related to the steering speed of 100 steering rotations/min.

Example:

For an ambient temperature of X °C the tank temperature stabilises at 60 °C. To achieve the optimum viscosity, this relates to the viscosity classes of VG 46 or VG 68; → VG 68 should be selected.

Pressure fluid filtration

The finer the filtration the higher the cleanliness class of the pressure fluid is achieved and so the higher the service life of the entire hydraulic system.

Note: To ensure the functionality of the steering pump a minimum pressure fluid cleanliness class of 19 / 16 / 13 to ISO 4406 is necessary (see [Technical data](#) on page 13).



Caution: Operating the unit with contaminated hydraulic fluid may lead to the steering system failing.

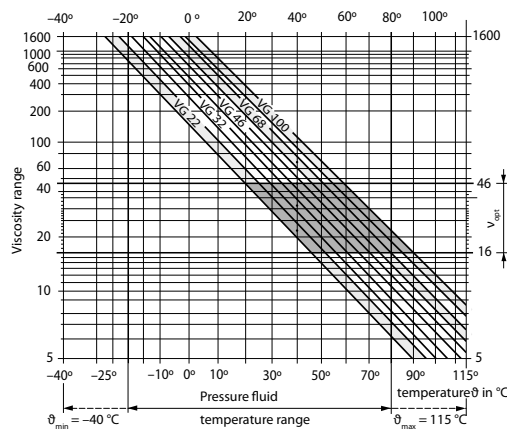

Figure 6: Selection diagram

Calculating the steering moment

Table 3: Formula symbols

Formula symbol	Designation	Unit
A	Required cylinder area	mm ²
A ₁	Cylinder piston area, differential cylinder	mm ²
A ₂	Cylinder ring area, differential cylinder	mm ²
b	Tyre width	mm
d	Piston rod diameter	mm
D	Cylinder diameter	mm
e	Distance of swivel bearing to center of tire	mm
F	Steering force	N
F _A	Steering axle force	N
h	Cylinder stroke length	mm
i	No. of steering wheel turns	
l	Smallest, effective steering lever	mm

Formula symbol	Designation	Unit
M	Steering moment	Nm
n	Steering wheel rotational speed	min ⁻¹
n _{leer}	Motor idling RPM	min ⁻¹
n _{Motor}	Motor operating RPM	min ⁻¹
p	Steering pressure	bar
q _{vp}	Pump flow	l/min
V	Steering unit displacement	cm ³ /U
V _p	Steering pump displacement	cm ³ /U
V _{ZYL}	Cylinder volume	cm ³
μ	Co-efficient of friction	

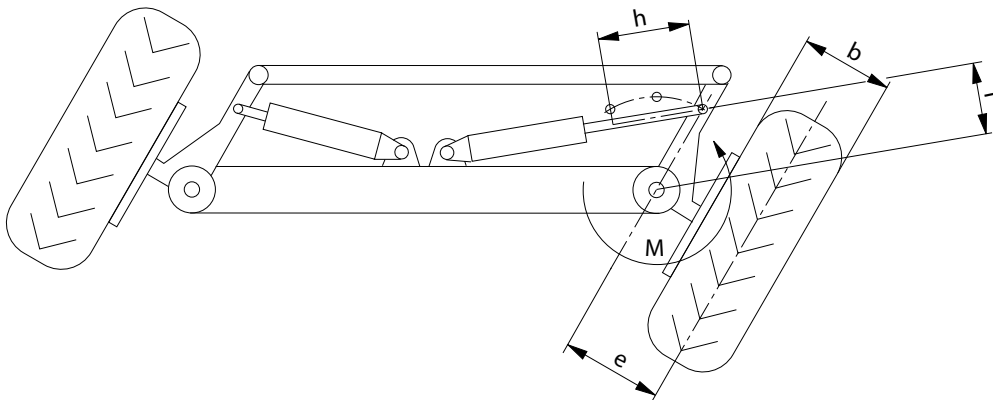

Figure 7: Steering geometry

$$M = 0,05 \cdot F_A \cdot \frac{1}{1 + \frac{e}{b}} \cdot \frac{b}{200} \cdot \frac{\mu}{0,7} \text{ [Nm]}$$

Figure 8: Steering moment

$$F = \frac{M}{l} \cdot 10^3 \text{ [N]}$$

Figure 9: Steering force

Defining the steering cylinder and steering pump

Steering cylinder

$$A = \frac{F}{p} \cdot 10 \text{ [mm}^2\text{]}$$

Figure 10: Required cylinder area

$$A_1 = \frac{\pi}{4} \cdot D^2 \text{ [mm}^2\text{]}$$

Figure 11: Cylinder area (piston side)

$$A_2 = \frac{\pi}{4} \cdot (D^2 - d^2) \text{ [mm}^2\text{]}$$

Figure 12: Cylinder area (rod side)

When using a differential or double roded cylinder, A_2 must be greater than the required cylinder area.

If two cross connected differential cylinders are to be used, then $A_1 + A_2$ must be greater than the required cylinder area.

The nominal size of steering unit results from the cylinder volume and the required number of steering wheel turns.

$$V_{ZYL} = \frac{A \cdot h}{10^3} \text{ [cm}^3\text{]}$$

Figure 13: Cylinder volume

$$V = \frac{V_{ZYL}}{i} \text{ [cm}^3\text{/U]}$$

Figure 14: Displacement volume LAGC

Normally there are 3 to 5 turns of the steering wheel from end stop to end stop.

Steering pump

The pump should be so selected that when the motor is idling, a steering velocity of approx. 50 min^{-1} can still be achieved. The maximum steering speed, which is dependent on the steering wheel diameter, is approx. 100 to 150 min^{-1} .

Volume flow of the pump $q_{VP} = V \cdot (n + 10) \cdot 10^{-3} \text{ l/min}$.

The pump displacement (\triangleq normal size) required for steering at idling speed and at operating speed of the vehicle must be calculated.

$$V_p = \frac{q_{VP} \cdot 10^3}{n_{leer}} \text{ [cm}^3\text{/U]}$$

Figure 15: Pump size at idling speed

$$V_p = \frac{q_{VP} \cdot 10^3}{n_{Motor}} \text{ [cm}^3\text{/U]}$$

Figure 16: Pump size at operating speed

Dimensions LAGU / LAGU LD / LAGU LDA

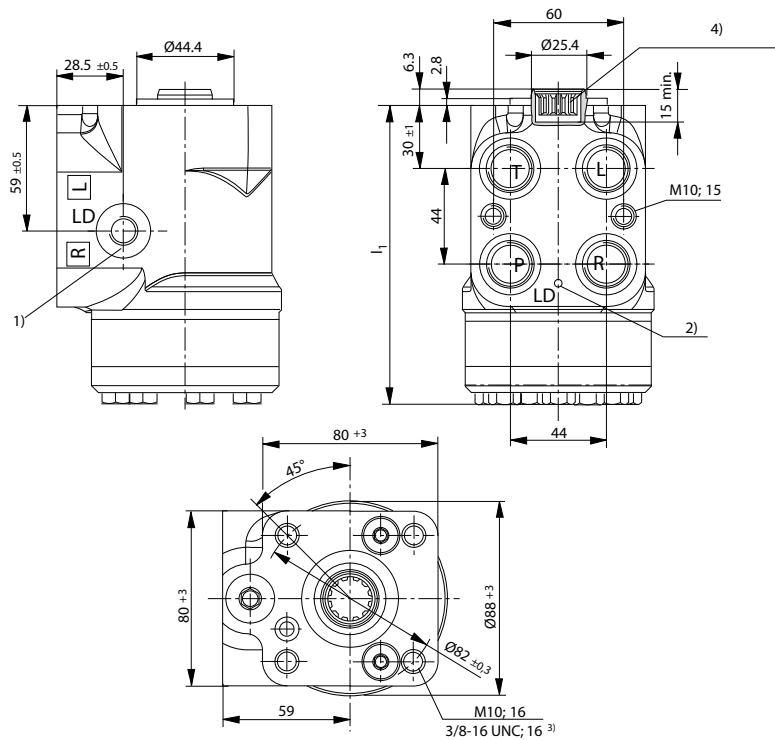

Figure 17: Dimensions for LAGU and LAGU LD & LDA versions (in mm)

- 1 LD threaded port only on version LAGU...LD...
- 2 LD hole only on version LAGU...LDA..., available up to 200 cm³/rev
- 3 Only for SAE thread code "12"
- 4 Gear hub profile 16/32 diametrical pitch to ANS B921-1970

Nom. size	l
100 / 50	132
125 / 60	135
140 / 70	137
160 / 80	139
180 / 90	142
200 / 100	145
250 / 125	151
320 / 160	161

Ports LAGU / LAGU LD / LAGU LDA

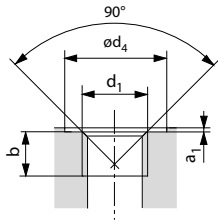

Figure 18: Imperial, metric thread

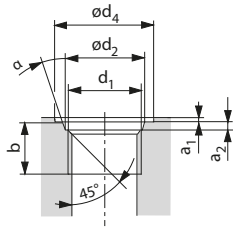

Figure 19: UNF, metric thread

Port	Code	d ₁	Ø d ₂	Ø d ₄	b _{min.}	a ₁	a ₂	α
P, T, L, R	01	G 1/2	-	28 ^{+0.4}	14	max. 0.2	-	-
	02	M22 x 1.5	-	28 ^{+0.4}	14	max. 0.2	-	-
	06	M18 x 1.5	19.8 ^{+0.1}	29 ^{+0.4}	14.5	max. 0.2	2.4 ^{+0.4}	15 ^{0±1°}
	12 / 19	3/4-16 UNF	20.6 ^{+0.1}	30 ^{+0.5}	14.3	max. 0.2	2.4 ^{+0.4}	15 ^{0±1°}
	40 ¹	M18 x 1.5	-	25 ^{+0.4}	12	max. 0.2	-	-
LD	01	G 1/4	-	25 ^{+0.4}	12	1±0.5	-	-
	02	M12 x 1.5	-	25 ^{+0.4}	12	1±0.5	-	-
	06	M12 x 1.5	13.8 ^{+0.1}	25 ^{+0.4}	11.5	1±0.5	2.4 ^{+0.4}	15 ^{0±1°}
	12 / 19	7/16-20 UNF	12.4 ^{+0.1}	21 ^{+0.5}	11.5	1±0.5	2.3 ^{+0.4}	12 ^{0±1°}
	40 ¹	M12 x 1.5	-	25 ^{+0.4}	12	1±0.5	-	-

Standards for hydraulic port dimensions:

01	DIN 3852-2 Form X
02	DIN 3852-1 Form X
06	ISO 6149-1
12	SAE J514
19	SAE J514
40	DIN 3852-1 Form X

¹ The LAGU...LDA.. version has generally ports according to code "40."

