



OIL SOLUTIONS

PO Box 38
Strathfieldsaye, VIC, 3551
1800 OIL SOL
1800 645 765
sales@oilsolutions.com.au
www.oilsolutions.com.au
"For All Your Hydraulic Needs"

Technical Information

OSPM Mini-Steering Unit

Contents

Chapter 1: Steering unit OSPM.....	5
Application.....	6
Advantages.....	6
Function.....	6
Versions.....	6
OSPM ON.....	7
OSPM PB.....	8
OSPM LS.....	8
Code numbers.....	9
OSPM Open-center Non-reaction steering units.....	9
OSPM Power Beyond steering units.....	10
OSPM Load Sensing steering units.....	10
OSPMS side-ported steering units.....	10
Variants and ordering specifications.....	10
Variants codes for OSPM, OSPMS, OSPMC, and OSPMSC MMC.....	11
Technical data.....	15
Displacement, flow and pressure OSPM/OSPMS/OSPMC/OSPMSC ON/PB.....	15
Displacement, flow and pressure OSPM/OSPMS/OSPMC/OSPMSC LS.....	16
Manual steering pressure.....	16
Valve function in OSPM steering units.....	16
Pressure relief valve.....	17
Pilot pressure relief valve.....	17
Shock valves.....	17
Check valve in P.....	17
Check valve in LS.....	18
Pressure drop in neutral.....	18
Weights.....	18
Port connections.....	21
Dimensions.....	22
OSPM dimensions.....	22
OSPMS dimensions.....	23
OSPMC dimensions.....	25
OSPMSC dimensions.....	26
 Chapter 2: Steering column for OSPM.....	 31
Load on integrated steering column.....	32
Load on the steering unit column.....	32
Installing the steering column.....	32
 Chapter 3: Conversion factors.....	 33

Chapter

1

Steering unit OSPM

Topics:

- *Application*
- *Advantages*
- *Function*
- *Versions*
- *Code numbers*
- *Variants and ordering specifications*
- *Technical data*
- *Dimensions*

Application

Examples:

- Compact-utility tractors
- Turfcare machines
- Universal tractors
- Forklift trucks
- Municipal vehicles
- ATV's

Advantages

- Small dimensions and low weight
- End ports with integrated fittings
- Easy installation and accessibility
- Possibility of integrated steering column
- Low pressure drop
- Low input torque
- Low system price
- Low noise

Function

OSPM is a hydrostatic steering unit which can be used with an add-on steering column, or with a steering column integrated unit. (type A or B).

The steering unit consists of a rotary valve and a rotary meter.

When the steering wheel is turned, oil is directed from the steering system pump via the rotary valve and rotary meter to the cylinder ports L or R, depending on the direction of turn. The rotary meter measures the oil flow to the steering cylinder in proportion to the angular rotation of the steering wheel.

If the oil supply from the steering system pump fails or is too small, the steering unit is able to work as a manual steering pump.

Versions

The mini-steering unit is available with the following valves: relief valve, shock and suction valves, check valve in P (in OSPM rear port versions only) and/or check valve in LS (standard in all LS versions). All OSPM's have check valve for emergency steering.

The OSPM is also available with an integrated steering column or alternatively in a version prepared for a flange-on steering column.

The connections are integrated endport fittings of the ORFS-type (O-ring face seal). See [Port Connections](#). Standard port size is 9/16"-18 UNF

OSPM steering unit is available in the following versions:

- **ON:** Open center non-reaction
- **PB:** Power Beyond non-reaction
- **LS:** Load Sensing dynamic non-reaction
- **X CN:** Closed center non-reaction, pilot steering unit for EHPS

The mini-steering unit is available with displacements of: 32, 40, 50, 63, 70, 80 and 100 cm³/rev. [1.95, 2.44, 3.05, 3.84, 4.27, 4.88 and 6.10 in³/rev.]

Table 1: Versions detailed overview

OSPM Feature	Standard	Optional	Note
Check valve for emergency steering	●	–	All versions
With integrated relief and/or shock valves	–	●	–
Check valve in P port	–	●	Rear port versions with integrated fittings (ORFS type, O-ring face seal)
Check valve in LS port	●	–	All LS versions
For direct steering wheel mount	●	–	With male shaft - 2 different types of hub
For steering column mount	●	–	<ul style="list-style-type: none"> • 9 teeth male shaft and 4x M6 thread holes (for OSPM and OSPMS) • 12 teeth female spline and 4x M10 thread holes (for OSPMC and OSPMSC).

Note:

For more information about port connections see [Rear-ported OSPM port connections](#) on page 21 and the catalog Technical Information General Steering Components, **BC152886484183**, section *Demands on steering columns* for installation dimensions for steering column end towards steering unit.

OSPM ON

Open center steering units have open connection between pump and tank in the neutral position.

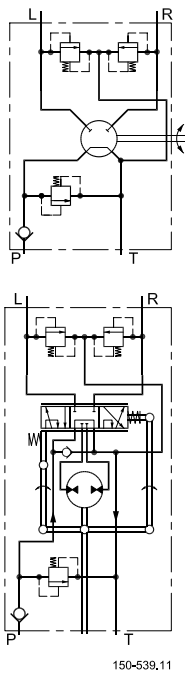

OSPM PB

While in the neutral position, Power Beyond steering units route oil from the pump through to the E-port.

The steering function always has priority, with any excess oil flow passing through the E port.

If the steering wheel is held at full lock, all flow is led to tank across the pressure relief valve, and flow from the E port will stop.

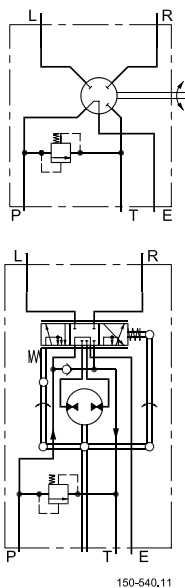

Figure 1: OSPM PB

OSPM LS

In load sensing steering systems both the steering system and the working hydraulics can be supplied with oil from the same pump. The load sensing steering unit works in line with a priority valve and can be connected in parallel with working hydraulics. The priority valve ensures that the steering unit always has priority of the oil supply from

the pump before any working hydraulics. Steering input is signalled back to the priority valve and/or a load sense pump through an extra port on the steering unit. The load sense signal controls the oil flow from the priority valve (and/or LS pump). When the steering wheel is in neutral full flow is available for the working hydraulics connected to the excess flow port of the priority valve. All OSPM LS steering units are dynamic type.

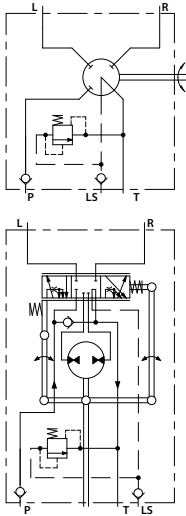

Figure 2: OSPM LS

Code numbers

OSPM Open-center Non-reaction steering units

Table 2: OSPM Open center Non-reaction (OSPM ON) code numbers

Steering unit	Code No. OSPM	Relief valve		Shock valves		Check valve in P- port	Steering wheel connection
		bar	[psi]	bar	[psi]		
OSPM 32 ON	150L0101	None		None		None	Flanged-on
OSPM 32 ON	150L2103	75-80	[1087-1160]	None		None	Flanged-on
OSPM 50 ON	150L2114	75-80	[1087-1160]	None		None	Integrated type A
OSPM 50 ON	150L2150	90-95	[1305-1378]	150-170	[2175-2465]	Yes	Integrated type A
OSPM 50 ON	150L2132	75-80	[1087-1160]	None		None	Integrated type B
OSPM 80 ON	150L0121	None		None		None	Flanged-on
OSPM 80 ON	150L2123	75-80	[1087-1160]	None		None	Flanged-on
OSPM 80 ON	150L2136	75-80	[1087-1160]	None		None	Integrated type B

Steering unit	Code No. OSPM	Relief valve		Shock valves		Check valve in P- port	Steering wheel connection
		bar	[psi]	bar	[psi]		
OSPM 100 ON	150L0156	75-80	[1087-1160]	None		None	Integrated type B

OSPM Power Beyond steering units

Table 3: OSPM Power Beyond (OSPM PB) code numbers

Steering unit	Code No. OSPM	Relief valve		Shock valves		Check valve in P- port	Steering wheel connection
		bar	[psi]	bar	[psi]		
OSPM 32 PB	150L0107	75-80	[1087-1160]	None		None	Flanged-on
OSPM 50 PB	150L2117	75-80	[1087-1160]	None		None	Flanged-on
OSPM 80 PB	150L0139	None		None		None	Integrated type B

OSPM Load Sensing steering units

Table 4: OSPM Load Sensing (OSPM LS) code numbers

Steering unit	Code No.	Relief valve		Shock valves		Check valve in P-port	Check valve in LS-Port	Steering wheel connection
		bar	[psi]	bar	[psi]			
OSPM 80 LS	11059680	75-80	[1087-1160 0]	None		Yes	Yes	Flanged-on

OSPMS side-ported steering units

Table 5: OSPMS side-ported (OSPM S ON) code numbers

Steering unit	Code No.	Relief valve		Shock valves		Check valve in P- port	Steering wheel connection
		bar	[psi]	bar	[psi]		
OSPM S 100 ON	11059689	75-80	[1087-1160]	None		None	Flanged-on

If you wish other versions of OSPM as included in the above codes, please fill in the order in section [Variants codes for OSPM, OSPMS, OSPMC, and OSPMSC MMC](#) on page 11, and contact the sales organisation.

Variants and ordering specifications

OSPM, OSPMS, OSPMC and OSPMSC MMC

Determine Master Model Code (MMC). Fill in the codes to specify OSPM steering unit.

MMC-pos.	1	2	3	4	5	6	7
----------	---	---	---	---	---	---	---

Type	Displacement	Circuit Type	PTL&R Size	PTL&R Interface	Column Thread	LS/E Size
Your OSPM						
Example	OSPM##	0080	LS##	RRRR	R	A R

MMC-pos.	8	9	10	11	12	13	14
	LS/E Interface	LS/E Location	Relief Valve	Shock Valves	Suction Valves	Check Valves	Neutral Springs
Your OSPM							
Example	R	A	075	NNN	N	4	N10

MMC-pos.	15	16	17	18	19
	Spool/Sleeve Set	Gear Set	Special	Label	Paint
Your OSPM					
Example	SN1	G01	NN	DNFS	PB

OSPM 80 LS example: based on code 11059680

Variants codes for OSPM, OSPMS, OSPMC, and OSPMSC MMC

MMC pos. 1	Main steering product Type
OSPM##	OSPM Steering units, rear-ported, male shaft: For column
OSPMA#	OSPM Steering units, rear-ported, male shaft: For steering wheel A type
OSPMB#	OSPM Steering units, rear-ported, male shaft: For steering wheel B type
OSPMXB	OSPM pilot Steering units for EHPS, rear-ported, male shaft: For steering wheel B type
OSPMS#	OSPMS Steering units, side-ported, male shaft: For column
OSPMSA	OSPMS Steering units, side-ported, male shaft: For steering wheel A type
OSPMSB	OSPMS Steering units, side-ported, male shaft: For steering wheel B type
OSPMC#	OSPM Steering units, rear-ported, female shaft: 12 teeth for standard column
OSPMSC	OSPMS Steering units, side-ported, female shaft: 12 teeth for standard column
OSPMCX	OSPMC pilot Steering units for EHPS, rear-ported, female shaft: 12 teeth for standard column
MMC pos. 2	Displacement, cm ³ /rev
0032	32
0040	40
0050	50
0063	63
0070	70
0080	80
0100	100

MMC pos. 3	Circuit Type
ON##	Open center Non-reaction
PB##	Power Beyond Non-reaction
LS##	Load Sensing Non-reaction
CN##	Closed Center for X-types
MMC pos. 4	P, T, L & R Port Size
RRRR	9/16"-18 UNF (ORFS, ISO 8434-3) (OSPM/OSPMC)
SSSS	11/16"-16 UNF (ORFS, ISO 8434-3) (OSPM/OSPMC)
SSRR	P&T: 11/16"-16 UNF , L&R: 9/16"-18 UNF (ORFS, ISO 8434-3) (OSPM/OSPMC)
EEEE	M14x1.5 (ISO 6149-1) (OSPMS/OSPMSC)
TTTT	9/16"-18 UNF (ISO 11926-1) (OSPMS/OSPMSC)
MMC pos. 5	P, T, L & R Port Interface
R	ORFS, ISO 8434-3 (OSPM/OSPMC)
A	O-ring boss + Spot-face (ISO 6149-1) (OSPMS/OSPMSC)
C	O-ring boss + Spot-face (ISO 11926-1) (OSPMS/OSPMSC)
MMC pos. 6	Column Thread
A	M6, M8 ears (ears on end cover) (OSPM)
B	M6 (OSPM/OSPMS and OSPMC/OSPMSC w. round flange for column)
M	M10x1,5 (OSPMC and OSPMSC w. square flange for column)
MMC pos. 7	LS/E Port Size
N	No LS/E Port
R	LS/E: 9/16"-18 UNF (ORFS, ISO 8434-3) (OSPM/OSPMC)
S	LS/E: 11/16"-16 UNF (ORFS, ISO 8434-3) (OSPM/OSPMC)
F	LS: M14x1.5 (ISO 6149-1) (OSPMS/OSPMSC)
T	LS/E: 9/16"-18 UNF (ISO 11926-1) (OSPMS/OSPMSC)
MMC pos. 8	LS/E Port Interface
N	No LS/E Port
R	ORFS, ISO 8434-3 (OSPM/OSPMC)
A	O-ring boss + Spot-face (ISO 6149-1) (OSPMS/OSPMSC)
C	O-ring boss + Spot-face (ISO 11926-1) (OSPMS/OSPMSC)
MMC pos. 9	LS/E Port Location
N	No LS/E Port
A	LS/E: End-ported (OSPM/OSPMC)
B	LS/E: Side-ported (OSPMS/OSPMSC)
MMC pos. 10	Relief Valve
NNN	No Relief Valve

MMC pos. 10	Relief Valve
075	Value for setting (75 bar), P-T. Range OSPM: 40 - 150 bar
MMC pos. 11	Shock Valves
NNN	No Shock Valves
125	Value for setting (125 bar), R-T/L-T. Range OSPM: 95 - 200 bar, last digit: 0 or 5
MMC pos. 12	Suction Valves
N	No Suction Valves
1	With Suction Valves. Only available for OSPM ON
MMC pos. 13	Check Valves
N	No Check Valves
1	Check Valve in P
4	Check Valve in P and in LS
MMC pos. 14	Neutral Springs
N10	150L4055, torque 0.5-2 Nm in normal steering situations. Soft
N11	150L4058, torque 0.8-2.7 Nm in normal steering situations. Soft - Medium
N12	150L4093, torque 1.1-3.5 Nm in normal steering situations. Medium
N13	150L4094, torque 1.6-4 Nm in normal steering situations. Strong
MMC pos. 15	Spool/Sleeve Set
SM1	OSPM/OSPMS ON. For pump flow range 4-12 l/min. Type Column
SM2	OSPM/OSPMS ON. For pump flow range 5-20 l/min. Type Column
SM3	OSPM/OSPMS ON. For pump flow range 5-20 l/min. Type A
SM4	OSPM/OSPMS ON. For pump flow range 4-12 l/min. Type B
SM5	OSPM/OSPMS ON. For pump flow range 5-20 l/min. Type B
SM6	OSPM/OSPMS PB. For pump flow range 5-20 l/min. Type Column
SM7	OSPM/OSPMS PB. For pump flow range 5-20 l/min. Type A
SM8	OSPM/OSPMS PB. For pump flow range 5-20 l/min. Type B
SN1	OSPM/OSPMS LS. Dynamic flow range 0.6-0.9 l/min. Type Column
SN2	OSPM/OSPMS LS. Dynamic flow range 0.6-0.9 l/min. Type A
SN3	OSPM/OSPMS LS. Dynamic flow range 0.6-0.9 l/min. Type B
SNA	OSPM/OSPMS LS. Dynamic flow range 0.6-0.9 l/min. Hissing muted. Type Column
SX7	OSPM/OSPMS CN. For EHPS. Type B
SC1	OSPMC/OSPMSC ON. For pump flow range 5-20 l/min. Type Column, 12 teeth
SC2	OSPMC/OSPMSC PB. For pump flow range 5-20 l/min. Type Column, 12 teeth
SC3	OSPMC/OSPMSC LS. Dynamic flow range 0.6-0.9 l/min. Hissing muted. Type Column, 12 teeth
SX8	OSPMCX CN. For EHPS. Type Column, 12 teeth

MMC pos. 16	Gear Set
G01	Profile grinding
G02	Profile grinding. With Sealed Star
MMC pos. 17	Special
NN	Not Applicable
CP	Corrosion Protected Shaft. Only available for Spool/Sleeve Sets for <ul style="list-style-type: none"> • OSPM/OSPMS ON. For pump flow range 5-20 l/min. Type B • OSPM/OSPMS PB. For pump flow range 5-20 l/min. Type B
MMC pos. 18	Label
DNFS	Standard Label
XXXX	Special Label
MMC pos. 19	Paint
PB	Black, Powder, RAL 9005 ; Corrosion class C3 ; Standard covering

Technical data

Displacement, flow and pressure OSPM/OSPMS/OSPMC/OSPMSC ON/PB

Steering unit	Displacement		Recommended oil flow		Max pressure on connections							
					System pressure P-T port pressure		T, absolute port pressure		L-T/R-T port pressure		System pressure LS-T port pressure	
	cm ³ /rev	[in ³ /rev]	l/min	[US gal/min]	bar	[psi]	bar	[psi]	bar	[psi]	bar	[psi]
OSPM 32 ON	32	[1.95]	3-9	[0.8-2.4]	150	[2180]	20	[290]	200	[2900]	-	
OSPM 40 ON	40	[2.44]	4-12	[1.1-3.2]								
OSPM 50 ON	50	[3.05]	5-15	[1.3-4.0]								
OSPM 63 ON	63	[3.84]	6-18	[1.6-4.8]								
OSPM 70 ON	70	[4.27]	7-20	[1.9-5.3]								
OSPM 80 ON	80	[4.88]	7-20	[1.9-5.3]								
OSPM 100 ON	100	[6.10]	7-20	[1.9-5.3]								
OSPM 32 PB	32	[1.95]	3-20	[0.8-5.3]							150	[2180]
OSPM 40 PB	40	[2.44]	4-20	[1.1-5.3]								
OSPM 50 PB	50	[3.05]	5-20	[1.3-5.3]								
OSPM 63 PB	63	[3.84]	6-20	[1.6-5.3]								
OSPM 70 PB	70	[4.27]	7-20	[1.9-5.3]								
OSPM 80 PB	80	[4.88]	7-20	[1.9-5.3]								
OSPM 100 PB	100	[6.10]	7-20	[1.9-5.3]								

* Criteria for determining the recommended oil flow:

- The minimum is the oil flow it takes to ensure sufficient steering speed at idle motor speed
- Must ensure the least possible pressure loss at full speed

The steering unit can cope with an oil flow that is up to 50% higher than the maximum recommended value.

Displacement, flow and pressure OSPM/OSPMS/OSPMC/OSPMSC LS

Steering unit	Displacement		Rated oil flow		Max pressure on connections							
	cm ³ /rev	[in ³ /rev]	l/min	[US gal/min]	System pressure P-T port pressure		T, absolute port pressure		L-T/R-T port pressure		System pressure LS-T port pressure	
					bar	[psi]	bar	[psi]	bar	[psi]	bar	[psi]
OSPM 32 LS	32	[1.95]	3	[0.79]	150	[2180]	20	[290]	200	[2900]	150	[2180]
OSPM 40 LS	40	[2.44]	4	[1.06]								
OSPM 50 LS	50	[3.05]	5	[1.32]								
OSPM 63 LS	63	[3.84]	6	[1.58]								
OSPM 70 LS	70	[4.27]	7	[1.85]								
OSPM 80 LS	80	[4.88]	8	[2.11]								
OSPM 100 LS	100	[6.10]	10	[2.64]								

Manual steering pressure

Under normal operation, where the steering pump supplies an adequate oil flow at the required pressure, the maximum torque on the steering wheel will not exceed 2 Nm [17.7 lbf·in]. If the oil flow from the steering system pump fails or is too small, the steering unit functions automatically as a manual steering pump.

Manual steering should only be used for emergency control of the vehicle if a sudden drop of pump pressure occurs.

The table below shows the manual steering pressure (P_m) for all sizes of steering units type OSPM at a steering wheel torque of 80 N·m [708 lbf·in].

The values apply only if the suction conditions on the steering unit T port are adequate.

OSPM		32	40	50	63	80	100
P_m	bar	100	90	80	60	50	40
	[psi]	[1450]	[1305]	[1160]	[870]	[725]	[580]

Valve function in OSPM steering units

The data below comes from measurements on a representative sample of steering unit from production. Oil with a viscosity of 21 mm²/s [100 SUS] at 50°C [122°F] was used during measuring.

* Rated flow at app. 100 rpm steering wheel speed

Pressure relief valve

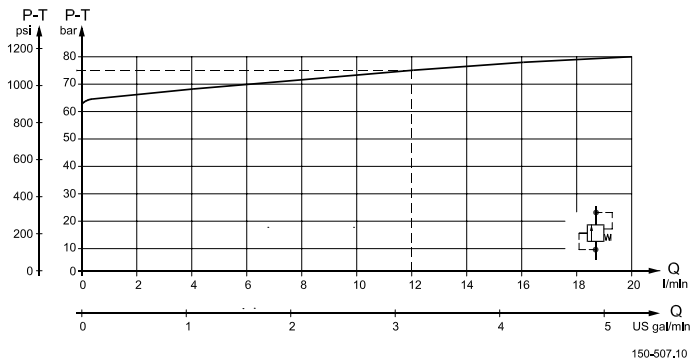

The pressure relief valve protects the pump and steering unit against excess pressure and limits the system pressure while steering.

The pressure relief valve in the steering unit will limit the maximum pressure drop from P to T.

The pressure relief valve is set at 12 l/min [3.17 US gal/min] flow.

Pilot pressure relief valve

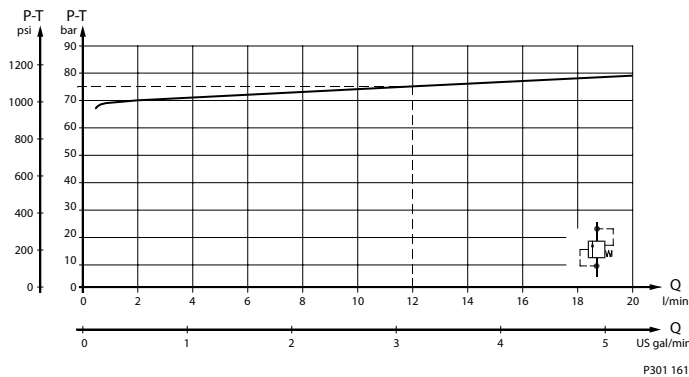

The pilot pressure relief valve together with the priority valve limits the maximum steering pressure P-T. The pilot pressure relief valve is set at an oil flow to the priority valve of 12 l/min [3.17 US gal/min]. For the OSPM LS load sensing dynamic steering units, the setting values are valid at a dynamic flow of 0.6 l/min [0.16 US gal/min].

Shock valves

The shock valves protect the steering unit against shocks from external forces on the steering cylinder. The shock valves in the steering unit limit the max pressure drop from L to T and from R to T. The shock valves are set at 1 l/min [0.27 US gal/min].

They are of the direct type and therefore have a very quick reaction. The setting tolerance is +20 bar [+290 psi].

Check valve in P

The check valve protects the driver against kickbacks in the steering wheel. It prevents the oil from flowing back into the pump line during steering under high pressure on the cylinder side. The check valve is mounted in the P-connection of the steering unit.

Check valve in LS

The check valve in the LS line of OSPM LS dynamic steering units protects the driver against steering wheel jerks. The check valve prevents oil from flowing backwards into the LS line to the priority valve, when steering against a high pressure on the cylinder side. This check valve is recommended to have in all OSPM LS dynamic variants.

Pressure drop in neutral

The pressure drop is measured with the steering unit in neutral position.

On the OSPM ON the pressure drop is measured from P to T.

On the OSPM PB the pressure drop is measured from P to E.

The following values are valid at an oil temperature of 50 °C [122 °F] for rear ported units and at a viscosity of 21 mm²/S [100 SUS]

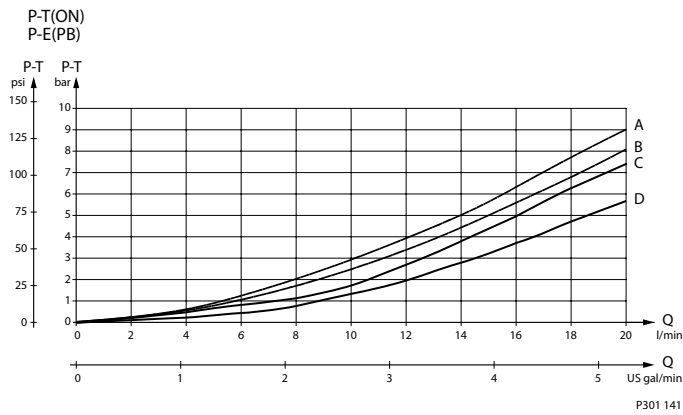

- A: OSPM 32 ON + all PB
- B: OSPM 50-100 ON
- C: OSPMS PB
- D: OSPMS ON

Weights

Type	Weight	
	kg	[lb]
OSPM 32 ON	2.3	[5.1]
OSPM 40 ON	2.4	[5.3]
OSPM 50 ON	2.5	[5.5]
OSPM 63 ON	2.6	[5.7]
OSPM 80 ON	2.7	[5.9]
OSPM 100 ON	2.9	[6.4]
OSPM 32 PB/LS	2.6	[5.7]
OSPM 40 PB/LS	2.7	[5.9]
OSPM 50 PB/LS	2.8	[6.2]

Type	Weight	
	kg	[lb]
OSPM 63 PB/LS	2.9	[6.4]
OSPM 80 PB/LS	3.0	[6.6]
OSPM 100 PB/LS	3.2	[7.1]
OSPMS 32 ON	2.5	[5.5]
OSPMS 40 ON	2.6	[5.7]
OSPMS 50 ON	2.7	[5.9]
OSPMS 63 ON	2.8	[6.2]
OSPMS 80 ON	2.9	[6.4]
OSPMS 100 ON	3.1	[6.8]
Type	Weight	
	kg	[lb]
OSPMS 32 PB/LS	2.9	[6.4]
OSPMS 40 PB/LS	3.0	[6.6]
OSPMS 50 PB/LS	3.1	[6.8]
OSPMS 63 PB/LS	3.2	[7.1]
OSPMS 80 PB/LS	3.3	[7.3]
OSPMS 100 PB/LS	3.5	[7.7]
OSPMC 32 ON, square flange for column	3.1	[6.8]
OSPMC 40 ON, square flange for column	3.2	[7.1]
OSPMC 50 ON, square flange for column	3.3	[7.3]
OSPMC 63 ON, square flange for column	3.4	[7.5]
OSPMC 80 ON, square flange for column	3.5	[7.7]
OSPMC 100 ON, square flange for column	3.7	[8.1]
OSPMC 32 PB/LS, square flange for column	3.3	[7.3]
OSPMC 40 PB/LS, square flange for column	3.4	[7.5]
OSPMC 50 PB/LS, square flange for column	3.5	[7.7]
OSPMC 63 PB/LS, square flange for column	3.6	[7.9]
OSPMC 80 PB/LS, square flange for column	3.7	[8.1]
OSPMC 100 PB/LS, square flange for column	3.9	[8.6]
OSPMC 32 ON, round flange for column	2.8	[6.2]
OSPMC 40 ON, round flange for column	2.9	[6.4]
OSPMC 50 ON, round flange for column	3.0	[6.6]
OSPMC 63 ON, round flange for column	3.1	[6.8]
OSPMC 80 ON, round flange for column	3.2	[7.1]

Type	Weight	
	kg	[lb]
OSPMC 100 ON, round flange for column	3.4	[7.5]
OSPMC 32 PB/LS, round flange for column	3.1	[6.8]
OSPMC 40 PB/LS, round flange for column	3.2	[7.1]
OSPMC 50 PB/LS, round flange for column	3.3	[7.3]
OSPMC 63 PB/LS, round flange for column	3.4	[7.5]
OSPMC 80 PB/LS, round flange for column	3.5	[7.7]
OSPMC 100 PB/LS, round flange for column	3.7	[8.1]
OSPMSC 32 ON, square flange for column	3.4	[7.5]
OSPMSC 40 ON, square flange for column	3.5	[7.7]
OSPMSC 50 ON, square flange for column	3.6	[7.9]
OSPMSC 63 ON, square flange for column	3.7	[8.1]
OSPMSC 80 ON, square flange for column	3.8	[8.4]
OSPMSC 100 ON, square flange for column	4.0	[8.8]
OSPMSC 32 PB/LS, square flange for column	3.7	[8.1]
OSPMSC 40 PB/LS, square flange for column	3.8	[8.4]
OSPMSC 50 PB/LS, square flange for column	3.9	[8.6]
OSPMSC 63 PB/LS, square flange for column	4.0	[8.8]
OSPMSC 80 PB/LS, square flange for column	4.1	[9.0]
OSPMSC 100 PB/LS, square flange for column	4.3	[9.5]
OSPMSC 32 ON, round flange for column	3.1	[6.8]
OSPMSC 40 ON, round flange for column	3.2	[7.1]
OSPMSC 50 ON, round flange for column	3.3	[7.3]
OSPMSC 63 ON, round flange for column	3.4	[7.5]
OSPMSC 80 ON, round flange for column	3.5	[7.7]
OSPMSC 100 ON, round flange for column	3.7	[8.1]
OSPMSC 32 PB/LS, round flange for column	3.5	[7.7]
OSPMSC 40 PB/LS, round flange for column	3.6	[7.9]
OSPMSC 50 PB/LS, round flange for column	3.7	[8.1]
OSPMSC 63 PB/LS, round flange for column	3.8	[8.4]
OSPMSC 80 PB/LS, round flange for column	3.9	[8.6]
OSPMSC 100 PB/LS, round flange for column	4.1	[9.0]

Port connections

Rear-ported OSPM port connections

The connections of all rear-ported OSPM steering unit codes in this Technical Information are 9/16-18 UNF of the O-ring face seal type (ORFS). O-rings are assembled into the O-ring groove (dovetail) of the fitting bolt from factory.

The integrated end-port fittings makes hose installation easy.

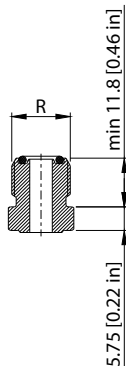

Figure 3: R: 9/16-18 UNF ORFS, ISO 8434-4

Dimensions of O-rings for 9/16-18 UNF ORFS ports: 7.65×1.78 mm [3.02×0.702 in] (SAE J515 seal size no. 011).

Rear-ported OSPM steering units are also available with 11/16-16UNF ORFS type.

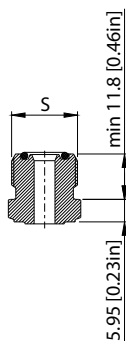

Figure 4: S: 11/16-16 UNF ORFS, ISO 8434-3

Dimensions of O-rings for 11/16-16 UN ORFS ports: 9.25×1.78 mm [0.334×0.0701 in]

Side-ported OSPM port connections

The standard port size for all side ported OSPMS versions in this Technical Information is 9/16-18 UNF

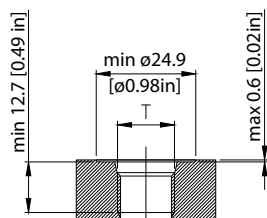

Figure 5: T: 9/16-18 UNF, ISO 11926-1

OSPMS is also available with M 14×1.5 :

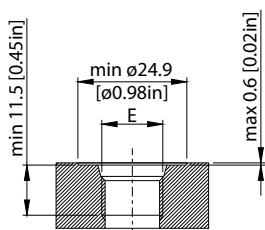

Figure 6: E: M14 x 1.5, ISO 6149-1

Dimensions

OSPM dimensions

OSPM dimension drawing

All dimensions in mm[in]

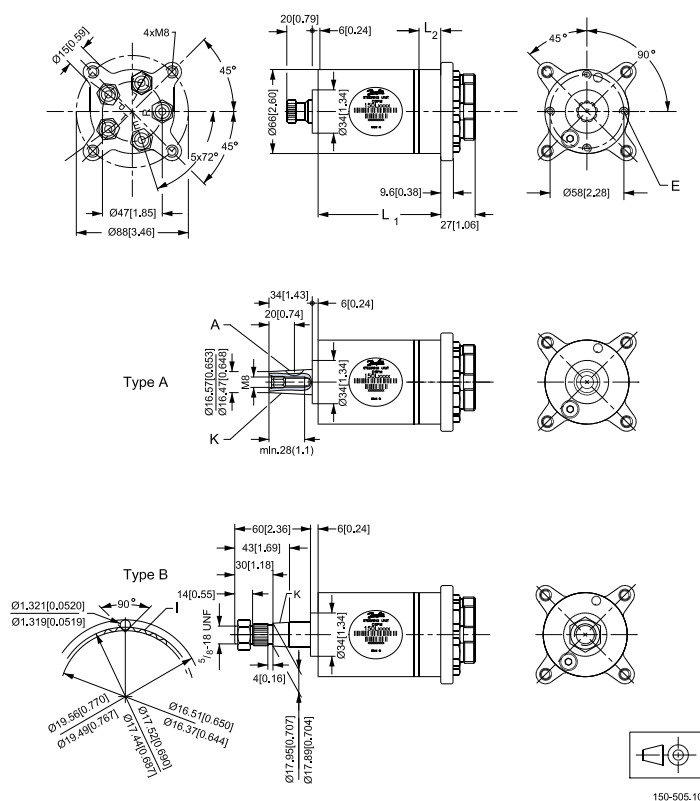

E: 4 × M6, 11 mm [0.432 in] deep

A: 5 × 6.5 DIN 6888
(Not included)

K: Taper 1:20
With 1 1/16 in - 40 serrations
dmin = 17.92 mm [0.72 in]

K: Taper 1:12

OSPM dimensions details

Mini steering unit	L ₁		L ₂	
	mm	[in]	mm	[in]
OSPM 32 ON	90	[3.54]	11.0	[0.43]
OSPM 40 ON	93	[3.66]	13.7	[0.54]
OSPM 50 ON	96	[3.78]	17.1	[0.67]
OSPM 63 ON	100	[3.94]	21.6	[0.85]
OSPM 70 ON	103	[4.05]	24.0	[0.94]
OSPM 80 ON	106	[4.17]	27.4	[1.08]
OPSM 100 ON	113	[4.45]	34.2	[1.35]
OSPM 32 PB/LS	103	[4.06]	11.0	[0.43]
OSPM 40 PB/LS	106	[4.17]	13.7	[0.54]
OSPM 50 PB/LS	109	[4.29]	17.1	[0.67]
OSPM 63 PB/LS	113	[4.45]	21.6	[0.85]
OSPM 70 PB/LS	116	[4.57]	24.0	[0.94]
OSPM 80 PB/LS	119	[4.69]	27.4	[1.08]
OSPM 100 PB/LS	126	[4.96]	34.2	[1.35]

OSPMS dimensions**OSPMS dimension drawing**

All dimensions in mm[in]

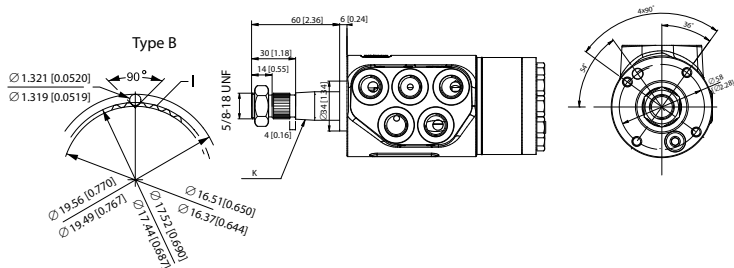
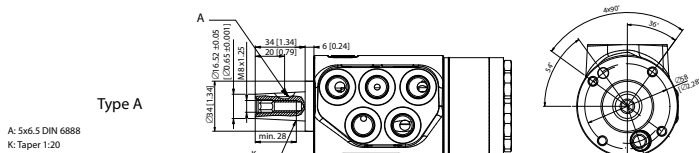
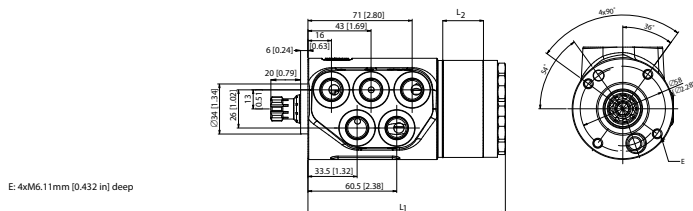

P301 150

With 1/16 in-40 serrations
dmin = 17.92 mm [0.72 in]

K: Taper 1:12

OSPMS dimensions details

Table 6: OSPMS dimensions

Mini steering unit OSPMS	L1		L2	
	Mm	[in]	mm	[in]
OSPMS 32 ON	107	[4.21]	11.0	[0.43]
OSPMS 40 ON	110	[4.33]	13.7	[0.54]
OSPMS 50 ON	114	[4.49]	17.1	[0.67]
OSPMS 63 ON	118	[4.65]	21.6	[0.85]
OSPMS 70 ON	120	[4.73]	24.0	[0.94]
OSPMS 80 ON	124	[4.89]	27.4	[1.08]
OSPMS 100 ON	131	[5.16]	34.2	[1.35]
OSPMS 32 PB/LS	120	[4.73]	11.0	[0.43]
OSPMS 40 PB/LS	122	[4.81]	13.7	[0.54]

Mini steering unit OSPMS	L1		L2	
	Mm	[in]	mm	[in]
OSPMS 50 PB/LS	126	[4.96]	17.1	[0.67]
OSPMS 63 PB/LS	130	[5.12]	21.6	[0.85]
OSPMS 70 PB/LS	133	[5.24]	24.0	[0.94]
OSPMS 80 PB/LS	136	[5.36]	27.4	[1.08]
OSPMS 100 PB/LS	143	[5.63]	34.2	[1.35]

OSPMC dimensions

OSPMC dimension drawing

All dimensions in mm[in]

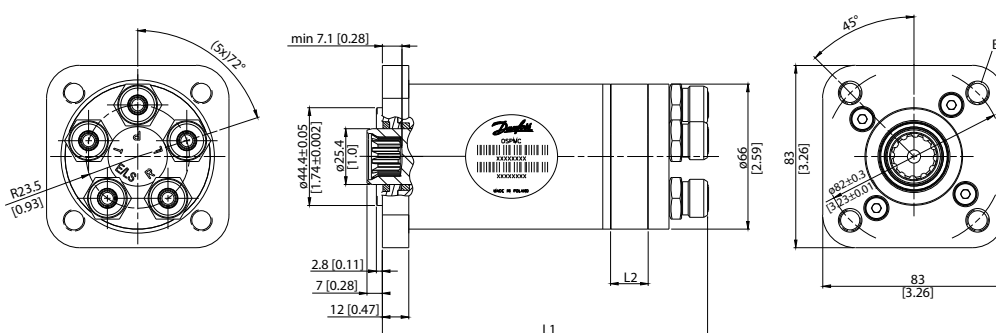

P, T, L, R, and PB/LS

9/16"-18 UNF, ORFS, ISO 8434-3

OR: 11/16"-16 UNF, ORFS, ISO 8434-3

B

M10 x 1.5, 12mm [0.47 in] deep

Figure 7: OSPMC w/ 12 teeth female splines and 4 x M10 thread for standard steering column.

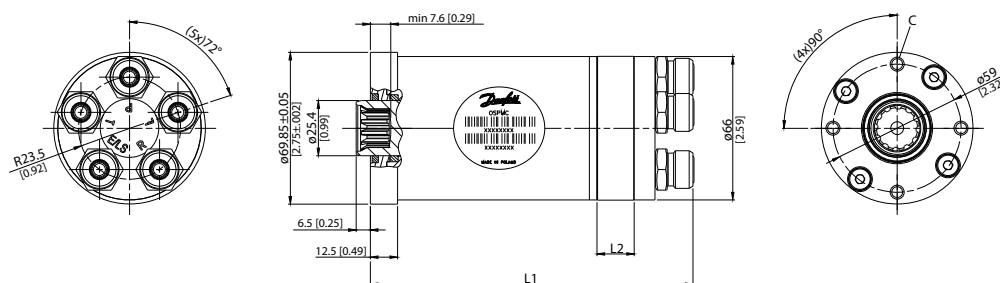

P, T, L, R, and PB/LS

9/16"-18 UNF, ORFS, ISO 8434-3

OR: 11/16"-16 UNF, ORFS, ISO 8434-3

C

M6 x 1, 12.5 mm [0.49 in] deep

Figure 8: OSPMC w/ 12 teeth femal splines and 4 x M6 thread for steering column

OSPMC dimensions details

Mini steering unit OSPMC w. square or round flange	L1		L2	
	mm	[in]	mm	[in]
OSPMC 32 ON	130	[5.12]	11.0	[0.43]
OSPMC 40 ON	133	[5.24]	13.7	[0.54]
OSPMC 50 ON	136	[5.36]	17.1	[0.67]
OSPMC 63 ON	141	[5.56]	21.6	[0.85]
OSPMC 70 ON	143	[5.63]	24.0	[0.94]
OSPMC 80 ON	147	[5.79]	27.4	[1.08]
OSPMC 100 ON	153	[6.03]	34.2	[1.35]
OSPMC 32 PB/LS	143	[5.63]	11.0	[0.43]
OSPMC 40 PB/LS	146	[5.75]	13.7	[0.54]
OSPMC 50 PB/LS	149	[5.87]	17.1	[0.67]
OSPMC 63 PB/LS	154	[6.07]	21.6	[0.85]
OSPMC 70 PB/LS	156	[6.15]	24.0	[0.94]
OSPMC 80 PB/LS	160	[6.30]	27.4	[1.08]
OSPMC 100 PB/LS	166	[6.54]	34.2	[1.35]

OSPMSC dimensions**OSPMSC dimension drawing**

All dimensions in mm[in]

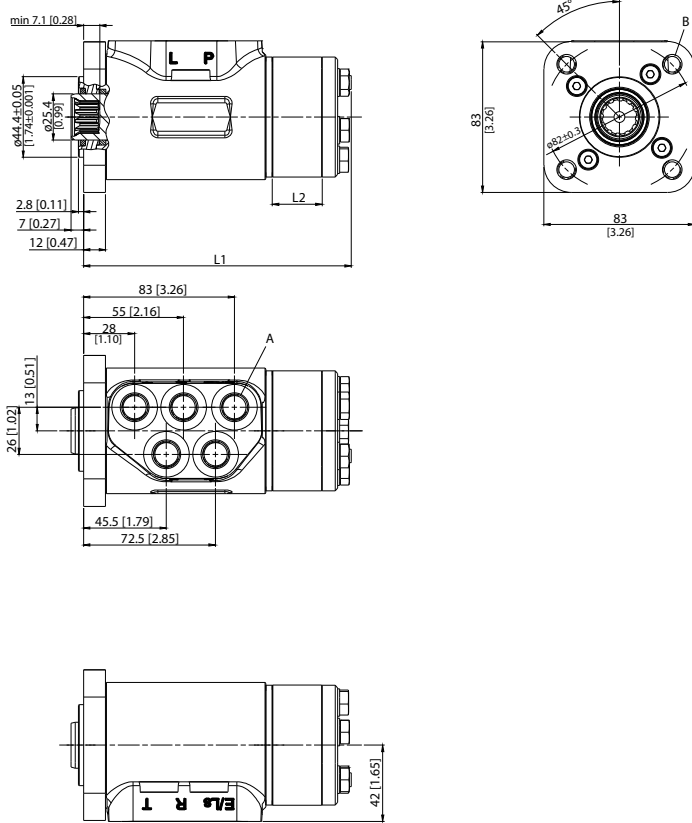

- A (P, T, L, R, and PB/LS)** 9/16"-18 UNF w/ O-ring boss and spot-face, ISO 11926-1, 12.7 mm [0.40 in] deep
 OR: M14 x 1.5 w/ O-ring boss and spot-face, ISO 6149-1, 11.5mm [0.45 in] deep
- B** M10 x 1.5, 12 mm [0.47 in] deep

Figure 9: OSPMSC w/ 12 teeth female splines and 4 x M10 thread for standard steering column

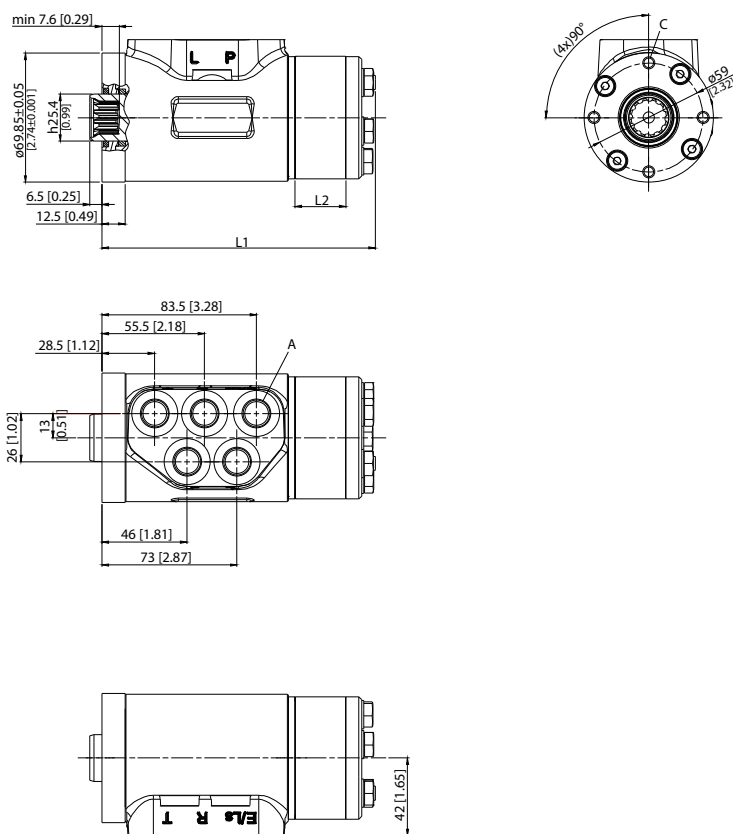

- A (P, T, L, R, and PB/LS)** 9/16"-18 UNF w/ O-ring boss and spot-face, ISO 11926-1, 12.7 mm [0.40 in] deep
 OR: M14 x 1.5 w/ O-ring boss and spot-face, ISO 6149-1, 11.5mm [0.45 in] deep
- C** M6 x 1, 12.5 mm [0.49 in] deep

Figure 10: OSPMSC w/ 12 teeth female splines and 4 x M6 thread for steering column

OSPMSC dimensions details

Mini steering unit OSPMSC w. square or round flange	L1		L2	
	Mm	[in]	mm	[in]
OSPMSC 32 ON	120	[4.73]	11.0	[0.43]
OSPMSC 40 ON	123	[4.85]	13.7	[0.54]
OSPMSC 50 ON	126	[4.96]	17.1	[0.67]
OSPMSC 63 ON	131	[5.16]	21.6	[0.85]
OSPMSC 70 ON	133	[5.24]	24.0	[0.94]
OSPMSC 80 ON	137	[5.40]	27.4	[1.08]
OSPMSC 100 ON	143	[5.63]	34.2	[1.35]
OSPMSC 32 PB/LS	133	[5.24]	11.0	[0.43]
OSPMSC 40 PB/LS	135	[5.32]	13.7	[0.54]
OSPMSC 50 PB/LS	139	[5.48]	17.1	[0.67]

Mini steering unit OSPMS w. square or round flange	L1		L2	
	Mm	[in]	mm	[in]
OSPMS 63 PB/LS	143	[5.63]	21.6	[0.85]
OSPMS 70 PB/LS	146	[5.75]	24.0	[0.94]
OSPMS 80 PB/LS	149	[5.87]	27.4	[1.08]
OSPMS 100 PB/LS	156	[6.15]	34.2	[1.35]

Chapter

2

Steering column for OSPM

Topics:

- *Load on integrated steering column*
- *Load on the steering unit column*
- *Installing the steering column*

Load on integrated steering column

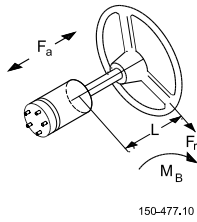

Symbols:

L (m/in): Axial length between OSPM housing and steering wheel

F_r (N/lb): Radial force on steering wheel

F_a (N/lb): Axial force on steering wheel

M_B (Nm/lbf·in): Bending moment on steering column $M_B = F_r \cdot L$

The following max. permissible values must not be exceeded:

M_B max.: 50 Nm [438 lbf·in]

F_r max: 500 N [112 lb]

F_a max: 600 N [135 lb]

With a given length L the max. force F_r on the steering wheel can be calculated:

$F_r = M_B \text{ max N}; L \text{ in m}$

$L + 0.015$

$F_r = M_B \text{ max lb}; L \text{ in inch}$

$L + 0.590$

Load on the steering unit column

The construction of the steering column must ensure that no axial or radial forces are transferred to the steering unit.

Such forces may prevent the steering unit from returning to neutral position automatically after a steering action has been completed.

Installing the steering column

Maximum tightening torque for fixing screws M6: 10^{+3}_{-0} N·m [88^{+27}_{-0} lbf·in]

M10: 30^{+5}_{-0} N·m [265^{+44}_{-0} lbf·in]

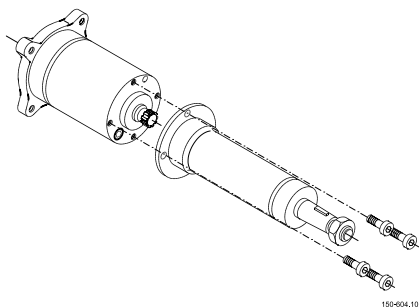

Chapter

3

Conversion factors

$$1 \text{ N}\cdot\text{m} = [8.851 \text{ lbf}\cdot\text{in}]$$

$$1 \text{ N} = [0.2248 \text{ lbf}]$$

$$1 \text{ mm} = [0.0394 \text{ in}]$$

$$1 \text{ cm}^3 = [0.061 \text{ in}^3]$$

$$1 \text{ l} = [0.264 \text{ US gal}]$$

$$1 \text{ bar} = [14.5 \text{ psi}]$$

$$^\circ\text{F} = [1.8^\circ\text{C} + 32]$$

