



OIL SOLUTIONS

---

**PO Box 38**  
**Strathfieldsaye, VIC, 3551**  
**1800 OIL SOL**  
**1800 645 765**  
**[sales@oilsolutions.com.au](mailto:sales@oilsolutions.com.au)**  
**[www.oilsolutions.com.au](http://www.oilsolutions.com.au)**  
**"For All Your Hydraulic Needs"**

# **Technical Information**

## **Steering unit LAGZ**



# Contents

<b>Chapter 1: Steering unit LAGZ.....</b>	<b>5</b>
Features.....	6
Ordering details.....	6
Function, section.....	8
Versions.....	10
Functions in a steering circuit.....	12
Technical data.....	13
Pressure fluid technical data.....	14
Calculating the steering moment.....	16
Defining the steering cylinder and steering pump.....	17
Unit dimensions: Type LAGZ / LAGZ LD.....	18
Ports: Type LAGZ / LAGZ LD.....	19



---

# Chapter

# 1

---

## Steering unit LAGZ

---

### Topics:

- *Features*
- *Ordering details*
- *Function, section*
- *Versions*
- *Functions in a steering circuit*
- *Technical data*
- *Pressure fluid technical data*
- *Calculating the steering moment*
- *Defining the steering cylinder and steering pump*
- *Unit dimensions: Type LAGZ / LAGZ LD*
- *Ports: Type LAGZ / LAGZ LD*

## Features

---

- LAGZ steering units are used in hydraulic steering circuits of vehicles and mobile machines with large axle loads and travel speeds not exceeding 60 kph.
- With the aid of a steering unit even heavy vehicles can easily be steered. The absence of a mechanical connection between the steering unit and the steering axle allows the designer to realize solutions, which would be impossible with conventional steering systems.
- In the event of a failure of the power assistance, vehicles can also be steered manually with the LAGZ. The required force is reduced by changing the transmission ratio. In many cases, only this feature makes it possible to adhere to the permissible limit values. A second steering pump is in many cases superfluous.
- In the power-assisted mode, the LAGZ operates with two rotor sets. In emergency operation, one rotor set is switched off. This allows several combinations (transmission ratios) within the rotor set sizes.

## Ordering details

---

The following table breaks down the ordering information for the LAGZ steering unit. Each entry in the leftmost column provides a component of the ordering number, with a result similar to the following: "LAG|Z|X|X|1x/X|X|X-X|M|X|\*"

The symbol "●" refers to the standard program, while the symbol "⦿" refers to the extended program.

Part number	Description	Code
LAG	Steering unit	
Z	Design with step-down ratio (2 rotor sets)	= Z

Part number	Description	Code
	<b>Displacement volume (cm<sup>3</sup>/rev)</b>	
	<b>Nom. size<sup>1</sup></b>	<b>R<sup>2</sup></b>
	Power assisted op.	Emergency op.
	125 / 60	●
	140 / 80	●
	160 / 60	•
	160 / 80	●
	190 / 60	•
	200 / 80	●
	220 / 60	•
	240 / 80	•
	300 / 100	•
	420 / 100	•
	500 / 100	●
	620 / 120	●
	<b>Noise characteristics</b>	
	Standard <sup>3</sup>	= -
	low <sup>4</sup>	= N
2x (/)	<b>Component series</b>	
	20 to 29	= 2x
	(20 to 29: unchanged installation and connection dimensions)	
	<b>Load sensing</b>	
	without load signal in open center	
	Without load signal in Open Center (OC) version	• = no code
	dynamic load signal	• = LD
	<b>Reaction</b>	
	without reaction	= no code
	with reaction	= R

<sup>1</sup> The here shown sizes are part of a preferred series, if you need others please ask your sales contact.

<sup>2</sup> With reaction is available up to nom. size of 260/60, all others are valid for Open Center and LD versions.

<sup>3</sup> To be used for LD / LDA versions

<sup>4</sup> Only with the open center (OC) version

Part number	Description	Code	
(-)	<b>Shock valve setting<sup>5</sup></b> (pressure differential)		
		150 bar	= 150
		200 bar	= 200
		240 bar	= 240
	<b>Pressure relief valve setting<sup>5</sup></b> (pressure differential)		
		90 bar	= 90
		140 bar	= 140
		175 bar	= 175
M	<b>Seals</b> NBR seals, suitable for mineral oil (HL, HLP) to DIN 51524	= M	
	<b>Pipe connections P, T, L, R/LD<sup>6</sup></b>		
		Pipe thread	● = 01
		Metric DIN thread	◐ = 02 / 40
		Metric ISO thread	◑ = 06
		SAE thread	◒ = 12 / 19
*	<i>Special specifications. Please clarify with our sales organization.</i>		

## Function, section

Control spool (1) of the control valve is rotated via the steering column in relation to control sleeve (2). This opens cross-sections between the spool and the sleeve. The pressurised oil acts on rotor sets (3 and 10) and sets them into motion. The oil is then fed via the rotor set to the steering cylinder. The rotation of both rotors acts on the sleeve, which then follows the rotary movement of the spool.

The size of the opened cross-sections depends on the turning speed of the steering wheel and on the steering pressure; on Load-Sensing versions, it depends exclusively on the turning speed.

If the steering movement is interrupted and the spool is at a standstill, the oil, which still flows through the open cross-section to the rotor, causes the rotor and hence the sleeve to continue to rotate a bit.

The rotary movement then causes the cross-section to close - now, the rotor also comes to a standstill and, at the same time, the steering cylinder is in the required position. The centering spring (4) brings and holds the spool and the sleeve in a neutral position to each other.

Pressure relief valve (5) limits the system pressure of the steering circuit. On the Load-Sensing versions, the pilot valve for the load signal is installed instead (see sectional drawing). Two shock valves (6) protect ports L and R to the

<sup>5</sup> The response pressure of the shock valves must be 50 bar higher, however a maximum of 2.2 times that of the hydraulic pump pressure relief valves. (see §38 StVZO, German Road Traffic Licensing Regulation) Preferably 150 to 90; 200 to 140; 240 to 175 bar.

<sup>6</sup> For thread dimensions see [Unit dimensions: Type LAGZ / LAGZ LD](#) on page 18

steering cylinder. If one of the shock valve opens, the discharged oil is fed via an anti-cavitation valve (7) to the opposite side, or missing leak-oil will be sucked from the tank.

In the event of an oil supply failure, the LAGZ operates as hand pump. In this case, the supply pressure (pilot pressure for the changeover spool) drops, too. Changeover spool (12) is moved to its starting position by the spring, so that all chambers of rotor set 2 (10) are connected to the an internal loop. At the same time, the connection between the two rotor sets gets interrupted. The displacement of the steering unit is therefore reduced by the volume of rotor set 2 (10). Rotor set 1 (3) determines the displacement during emergency operation.

Oil can be sucked from the tank via the suction check valve (8), the inlet check valve (9) prevents that air gets into the pump port (P). During normal operation, this valve prevents shocks or kick backs on the steering wheel caused by excessive external steering forces.

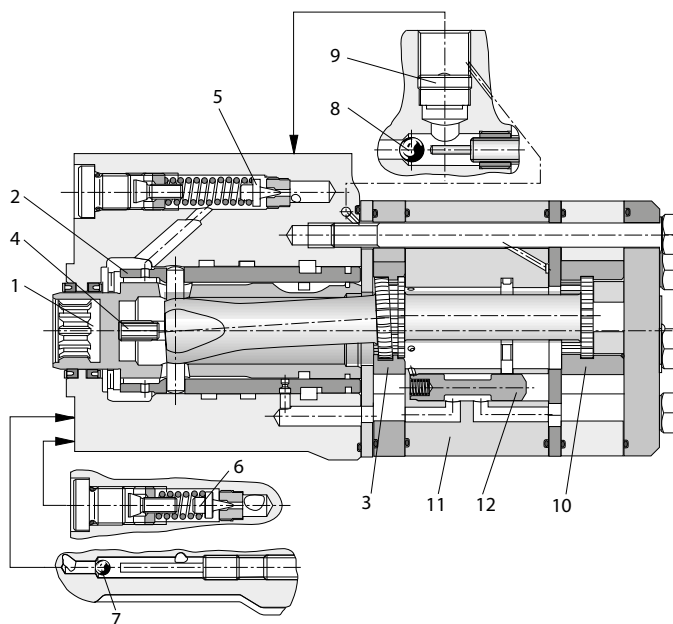

- |    |                       |
|----|-----------------------|
| 1  | Control spool         |
| 2  | Control sleeve        |
| 3  | Rotor set 1           |
| 4  | Centering spring      |
| 5  | Pressure relief valve |
| 6  | Anti-shock valve      |
| 7  | Anti-cavitation valve |
| 8  | Suction check valve   |
| 9  | Inlet check valve     |
| 10 | Rotor set 2           |
| 11 | Changeover housing    |
| 12 | Changeover spool      |

**Figure 1: Cross section LAGZ**

## Versions

### Standard version

#### Open center with Non Reaction = OC / NR

Mainly used in steering systems with fixed displacement hydraulic pumps.

When no steering movement is performed, the connection between pump port (P) and tank port (T) is open (OC), and the pump flow is directed to the tank almost at zero pressure. Ports L<sup>1</sup> (left) and R<sup>1</sup> (right) are blocked in the neutral position (NR). In this way, external forces acting via the steering cylinder are supported without the driver perceiving any resulting reaction forces on the steering wheel (Non Reaction).

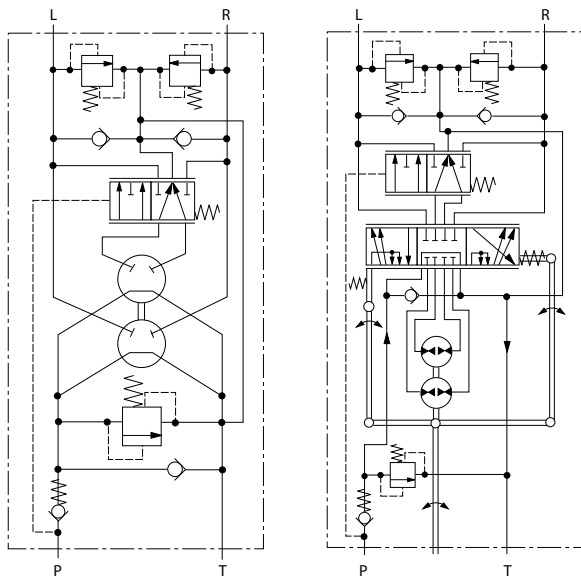

**Figure 2: LAGZ OC / NR**

**Note:** Steering units for vehicles with an articulated steering or with rear axle steering must always use the NR version.

### Standard version

#### Open center with Reaction = OC / R

In the neutral position, the cylinder ports are connected with each other. External forces acting via the steering cylinder are perceived as reaction force by the driver on the steering wheel (Reaction). When the driver releases the steering wheel after the steering maneuver is completed, the wheels and the steering wheel automatically return to straight-ahead travel, provided that the steering geometry is suitable for this.

<sup>1</sup> Contrary to standardization, the actuator lines in steering systems are usually designated “L” and “R”, not “A” and “B”.

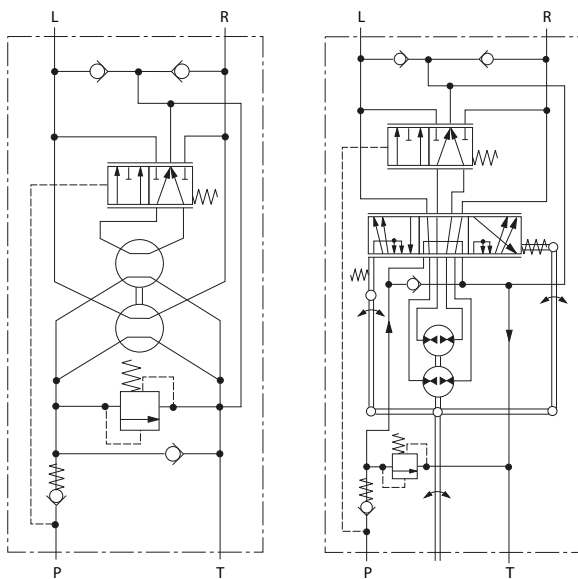

**Figure 3: LAGZ OC / R**

### Low-noise version

Steering units of the LAGZ Open Center versions are generally delivered in the low-noise variant “N”.

### Load sensing version

Steering units with load sensing provide a load signal that can be used to control a priority valve and/or a pump. They are designed as closed center steering systems whereby the connection pump (P) to tank (T) is locked while neutral position.

If the steering and implement hydraulics are supplied by a common pump then the use of a priority valve is necessary. The priority valve ensures that the steering unit gets a priority oil supply, whereby the control of the priority valve runs via the steering unit load signal. When steering is not operating then the entire oil flow from the pump is made available to the implement hydraulics. Fixed or variable displacement pumps can be used.

### Load signal, dynamic

There is always a recommended oil flow of approx. 0.5 - 1.0 l/min in the LS-line from the priority valve to the steering unit that transmits the load (pressure) signal from the steering unit to the priority valve. Consequently, the steering unit gets warmed up by this and has approximately the same temperature as the oil.

Thermal shocks are largely prevented.

The LD version causes the priority valve to react faster. The hard point at the beginning of the steering movement is usually no longer perceivable - even under cold start conditions.

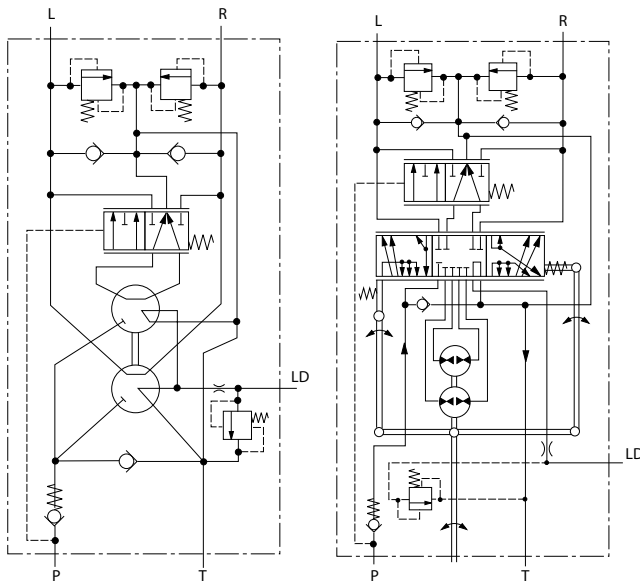

**Figure 4: LAGZ LD / R (left) and LAGC LD / NR (right)**

## Functions in a steering circuit

### Power-assisted mode - Servo operation

Steering units of type LAGZ consist of a manually operated rotary spool valve, two rotor sets, which operate according to the gerotor principle, and the required valves for the steering circuit.

The nominal size for the power-assisted mode results from the sum of the rotor set sizes. The size of that is to be selected so that with 3 to 5 turns of the steering wheel, it is possible to steer from one end stop to the other.

### Manual steering - Emergency mode

During normal operation of the steering unit, when a sufficient amount of oil gets supplied to the steering unit, the torque required on the steering wheel is  $< 5 \text{ Nm}$ . In the event that the oil supply fails, the steering unit operates in the emergency mode. The required steering pressure must then be generated by manual force on the steering wheel.

With the LAGZ, the displacement can be reduced by switching one rotor set off. The pressure that can be generated manually depends on the size of rotor set 1 (see page 5) and the force applied to the steering wheel. The smaller the displacement, the higher the pressure that can be built up manually.

For emergency operation, the size must be selected so that legal requirements with regard to the maximum manual force are complied with.

Taking account of the sizes for the displacement, certain combinations are possible for the relevant transmission ratio.

### Pressure relief valve

The pressure relief valve for the hydraulic pump is available in three standard pressure settings:

- 90 bar
- 140 bar
- 175 bar

Other settings are possible on request.

## Anti-shock valves

The cylinder side valves that are built into the LAGZ unit are available in three standard pressure settings:

- 150 bar
- 200 bar
- 240 bar

Other settings are possible on request.

**Note:** The pressure in the T line increases the set pressure by the equivalent value.

## Anti cavitation valves L and R

In the event of a negative pressure in the steer cylinder lines oil can be sucked from the T- area via the anti cavitation valves.

## Suction check valve T to P

If the hydraulic pump fails then the pressure fluid is drawn from the reservoir via this valve, which is fitted between the P and T connections.

## Inlet check valve

The check valve of the P-port prevents the return flow of oil from the steer cylinder - due to external forces working onto the steer cylinder - into the hydraulic system. So it prevents kick back turning of the steering wheel.

While manual steering it prevents sucking air from the P-port.



**Caution:** The emergency operating mode is not intended for continuous operation! If, for steering during emergency operation, a higher pressure is required then an emergency steering pump must be fitted.

## During manual steering, the following pressures can be achieved in dependence upon the steering moment:

$M_{\text{steer}}$	Nom. size	... / 60	... / 80	... / 100	... / 120
50 Nm	p in bar	40	30	24	15
70 Nm	p in bar	56	42	33	25

## Technical data

For applications outside of these parameters, please consult your service representative!

**Table 1: General**

Ambient temperature range	9	°C	-20 to +80
Steering moment - standard <sup>1</sup>	M	Nm	≤ 5
Steering moment - emergency operation	M	Nm	≤ 160 permissible
Max tightening torque $M_A$ for the mounting screws		Nm	30 see HE 11874 "steering column"

<sup>1</sup> Other steering moment variants (e.g. low) on request.

**Table 2: Hydraulic**

Nominal pressure	p	bar	175				
Pressure fluid	see <i>Pressure fluid technical data</i> on page 14						
Pressure fluid temperature range	ϑ	°C	- 20 to + 80				
Viscosity range	v	mm <sup>2</sup> /s	10 to 800				
max. permissible degree of contamination of the pressure fluid is to ISO 4406 (c)						class 19 / 16 / 13 <sup>2</sup>	
Steering unit Type	Displacement-volume Servo operation cm <sup>3</sup>	Displacement-volume Emergency operation cm <sup>3</sup>	Flow		max. perm. pressure in port		
			Nom. <sup>3</sup> l/min	max l/min	P bar	T bar	L and R bar
LAGZ 125 / 60	125	60	12.5	50	175	20	240
LAGZ 140 / 60	140	60	14.0	50	175	20	240
LAGZ 160 / 60	160	60	16.0	50	175	20	240
LAGZ 160 / 80	160	80	16.0	50	175	20	240
LAGZ 190 / 60	190	60	19.0	50	175	20	240
LAGZ 200 / 80	200	80	20.0	50	175	20	240
LAGZ 220 / 60	220	60	22.0	50	175	20	240
LAGZ 240 / 80	240	80	24.0	50	175	20	240
LAGZ 300 / 100	300	100	30.0	50	175	20	240
LAGZ 420 / 100	420	100	42.0	50	175	20	240
LAGZ 500 / 100	500	100	50.0	50	175	20	240
LAGZ 620 / 120	620	120	50.0 <sup>4</sup>	50	175	20	240

## Pressure fluid technical data

### Pressure fluids

Before carrying out any engineering please refer to the extensive information regarding pressure fluid selection and application conditions in standards or manufacturer instructions. For pressure fluids that require FKM or other seals please contact your sales contact.

### Operating viscosity

We recommend that the operating viscosity (at operating temperature) for efficiency and service life, is selected within the optimum range of

<sup>2</sup> The cleanliness classes specified for components must be adhered to in hydraulic systems. Effective filtration prevents malfunction and, at the same time, prolongs the service life of components.

<sup>3</sup> Related to the steering speed of 100 steering rotations/min.

<sup>4</sup> Design related is the flow rate limited onto 50 l/min of the LAGZ 620 / 120.

$v_{opt}$  = optimum operating viscosity range 16 to 46 mm<sup>2</sup>/s

with reference to the temperature.

### Limiting viscosity

For the limiting conditions the following values apply:

- $v_{min} = 10 \text{ mm}^2/\text{s}$  at a max. permissible temperature of  $\vartheta_{max} = + 80 \text{ }^\circ\text{C}$
- $v_{max} = 800 \text{ mm}^2/\text{s}$

### Temperature range (see selection diagram)

- $\vartheta_{min} = - 20 \text{ }^\circ\text{C}$
- $\vartheta_{max} = + 80 \text{ }^\circ\text{C}$

If there is the possibility of there being a temperature difference of more than 20 °C between the steering unit and the pressure fluid, then either a LD or LDA version or an open center version for warming the steering unit should be fitted.

### Further on the selection of pressure fluids

A prerequisite to being able to select the correct pressure fluid is knowing the operating temperature and the ambient temperature. The pressure fluid should be so selected that the operating viscosity at the working temperature lies within the optimum range (see selection diagram). We recommend that the next higher viscosity class is selected.

#### Example:

For an ambient temperature of X °C the tank temperature stabilises at 60 °C. To achieve the optimum viscosity, this relates to the viscosity classes of VG 46 or VG 68; → VG 68 should be selected.

### Pressure fluid filtration

The finer the filtration the higher the cleanliness class of the pressure fluid is achieved and so the higher the service life of the entire hydraulic system.

**Note:** To ensure the functionality of the steering pump a minimum pressure fluid cleanliness class of 19 / 16 / 13 to ISO 4406 is necessary (see [Technical data](#)).



**Caution:** Operating the unit with contaminated hydraulic fluid may lead to the steering system failing.

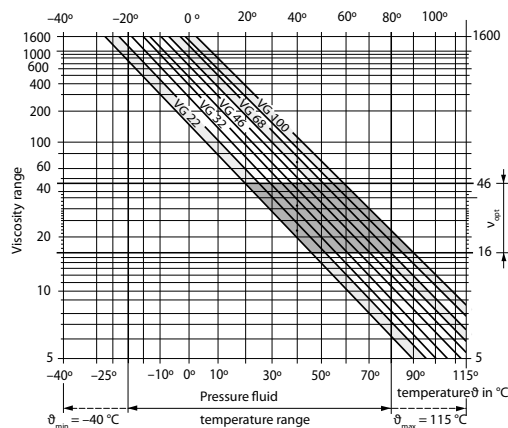
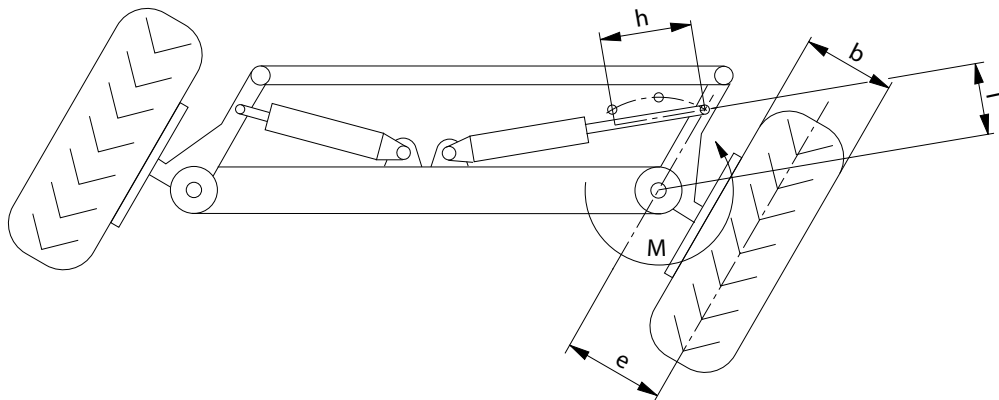

**Figure 5: Selection diagram**

## Calculating the steering moment

**Table 3: Formula symbols**

Formula symbol	Designation	Unit
A	Required cylinder area	mm <sup>2</sup>
A <sub>1</sub>	Cylinder piston area, differential cylinder	mm <sup>2</sup>
A <sub>2</sub>	Cylinder ring area, differential cylinder	mm <sup>2</sup>
b	Tyre width	mm
d	Piston rod diameter	mm
D	Cylinder diameter	mm
e	Distance of swivel bearing to center of tire	mm
F	Steering force	N
F <sub>A</sub>	Steering axle force	N
h	Cylinder stroke length	mm
i	No. of steering wheel turns	
l	Smallest, effective steering lever	mm
M	Steering moment	Nm
n	Steering wheel rotational speed	min <sup>-1</sup>
n <sub>leer</sub>	Motor idling RPM	min <sup>-1</sup>
n <sub>Motor</sub>	Motor operating RPM	min <sup>-1</sup>
p	Steering pressure	bar
q <sub>vp</sub>	Pump flow	l/min
V	Steering unit displacement	cm <sup>3</sup> /U
V <sub>p</sub>	Steering pump displacement	cm <sup>3</sup> /U
V <sub>ZYL</sub>	Cylinder volume	cm <sup>3</sup>
μ	Co-efficient of friction	



**Figure 6: Steering geometry**

$$M = 0,05 \cdot F_A \cdot \frac{1}{1 + \frac{e}{b}} \cdot \frac{b}{200} \cdot \frac{\mu}{0,7} \text{ [Nm]}$$

**Figure 7: Steering moment**

$$F = \frac{M}{l} \cdot 10^3 \text{ [N]}$$

**Figure 8: Steering force**

## Defining the steering cylinder and steering pump

---

### Steering cylinder

$$A = \frac{F}{p} \cdot 10 \text{ [mm}^2\text{]}$$

**Figure 9: Required cylinder area**

$$A_1 = \frac{\pi}{4} \cdot D^2 \text{ [mm}^2\text{]}$$

**Figure 10: Cylinder area (piston side)**

$$A_2 = \frac{\pi}{4} \cdot (D^2 - d^2) \text{ [mm}^2\text{]}$$

**Figure 11: Cylinder area (rod side)**

When using a differential or double roded cylinder,  $A_2$  must be greater than the required cylinder area.

**If two cross connected differential cylinders are to be used, then  $A_1 + A_2$  must be greater than the required cylinder area.**

The nominal size of steering unit results from the cylinder volume and the required number of steering wheel turns.

$$V_{zyl} = \frac{A \cdot h}{10^3} \text{ [cm}^3\text{]}$$

**Figure 12: Cylinder volume**

$$V = \frac{V_{zyl}}{i} \text{ [cm}^3\text{/U]}$$

**Figure 13: Displacement volume LAGC**

Normally there are 3 to 5 turns of the steering wheel from end stop to end stop.

### Steering pump

The pump should be so selected that when the motor is idling, a steering velocity of approx.  $50 \text{ min}^{-1}$  can still be achieved. The maximum steering speed, which is dependent on the steering wheel diameter, is approx.  $100$  to  $150 \text{ min}^{-1}$ .

**Volume flow of the pump  $q_{vp} = V \cdot (n + 10) \cdot 10^{-3} \text{ l/min}$ .**

The pump displacement ( $\triangleq$ normal size) required for steering at idling speed and at operating speed of the vehicle must be calculated.

$$V_p = \frac{q_{vp} \cdot 10^3}{n_{leer}} \text{ [cm}^3\text{/U]}$$

**Figure 14: Pump size at idling speed**

$$V_p = \frac{q_{p} \cdot 10^3}{n_{\text{Motor}}} \quad [\text{cm}^3/\text{U}]$$

**Figure 15: Pump size at operating speed**

## Unit dimensions: Type LAGZ / LAGZ LD

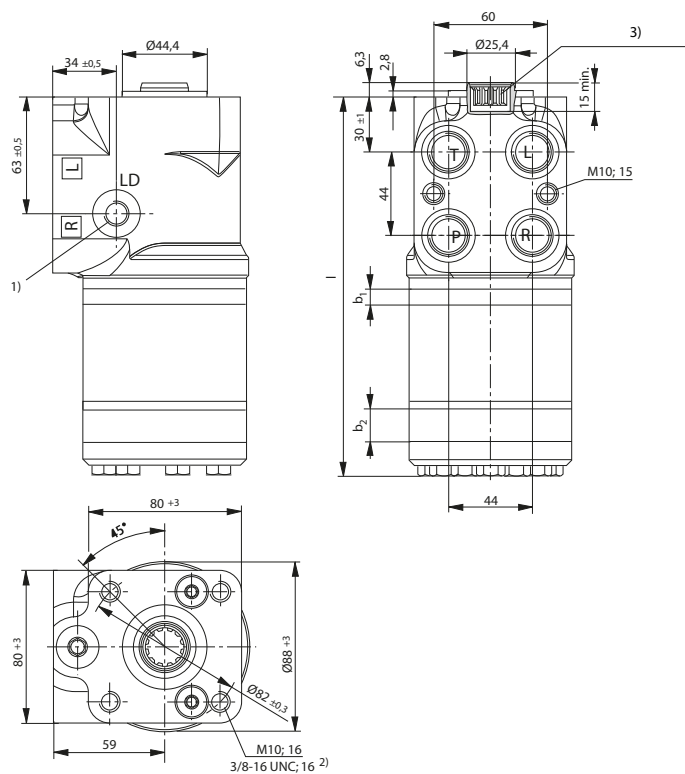

- 1 LD thread port only on version LAGZ...LD...
- 2 Only for SAE thread code "12"
- 3 Gear hub profile 16/32 diametrical pitch to ANS B921-1970

**Figure 16: Dimensions (in mm)**

Nom. size	l
125 / 60	188
140 / 60	190
160 / 60	192
160 / 80	192
190 / 60	195
200 / 80	197
220 / 60	200
240 / 80	202
300 / 100	212

Nom. size	l
420 / 100	229
500 / 100	239
620 / 120	255

## Ports: Type LAGZ / LAGZ LD

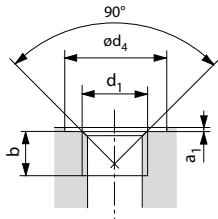

**Figure 17: Imperial, metric thread**

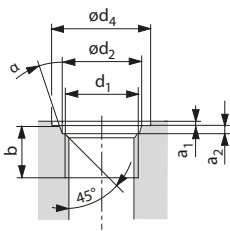

**Figure 18: UNF, metric thread**

Port	Version	d <sub>1</sub>	ød <sub>2</sub>	ød <sub>4</sub>	b <sub>min.</sub>	a <sub>1</sub>	a <sub>2</sub>	α
P, T, L, R	01	G 1/2	-	28 <sup>+0.4</sup>	14	max. 0.2	-	-
	02	M22 x 1.5	-	28 <sup>+0.4</sup>	14	max. 0.2	-	-
	06	M18 x 1.5	19.8 <sup>+0.1</sup>	29 <sup>+0.4</sup>	14.5	max. 0.2	2.4 <sup>+0.4</sup>	15 <sup>±1°</sup>
	12 / 19	3/4 -16UNF	20.6 <sup>+0.1</sup>	30 <sup>+0.5</sup>	14.3	max. 0.2	2.4 <sup>+0.4</sup>	15 <sup>±1°</sup>
	40	M18 x 1.5	-	25 <sup>+0.4</sup>	12	max. 0.2	-	-
LD	01	G 1/4	-	25 <sup>+0.4</sup>	12	1 <sup>±0.5</sup>	-	-
	02	M12 x 1.5	-	25 <sup>+0.4</sup>	12	1 <sup>±0.5</sup>	-	-
	06	M12 x 1.5	13.8 <sup>+0.1</sup>	25 <sup>+0.4</sup>	11.5	1 <sup>±0.5</sup>	2.4 <sup>+0.4</sup>	15 <sup>±1°</sup>
	12 / 19	7/16 -20UNF	12.4 <sup>+0.1</sup>	21 <sup>+0.5</sup>	11.5	1 <sup>±0.5</sup>	2.3 <sup>+0.4</sup>	12 <sup>±1°</sup>
	40	M12 x 1.5	-	25 <sup>+0.4</sup>	12	1 <sup>±0.5</sup>	-	-

**01**            DIN 3852-2 Form X

**02**            DIN 3852-1 Form X

**06**            ISO 6149-1

**12**            SAE J514

**19**

SAE J514

**40**

DIN 3852-1 Form X